

# **City of Tacoma Surface Water Management Manual**

---

## **Volume I Minimum Technical Requirements and Site Planning**

Prepared by:

Tacoma Public Works  
Environmental Services

January 2003



# Table of Contents – Volume I

---

<b>Acknowledgements .....</b>	<b>i</b>
<b>Chapter 1 – Introduction .....</b>	<b>1-1</b>
1.1 Objective .....	1-1
1.2 Relationship to Ecology’s Stormwater Manual .....	1-1
1.3 Organization of this Manual.....	1-2
1.3.1 Overview of Manual Content .....	1-2
1.3.2 Organization of this Manual.....	1-3
1.3.3 Organization of Volume 1 .....	1-3
1.4 How to Use this Manual.....	1-3
1.5 Development of Best Management Practices for Stormwater Management .....	1-4
1.5.1 Best Management Practices (BMPs).....	1-4
1.5.2 Source Control BMPs .....	1-4
1.5.3 Treatment BMPs.....	1-4
1.5.4 Flow Control BMPs .....	1-5
1.6 Relationship of this Manual to Federal, State, and Local Regulatory Requirements .....	1-6
1.6.1 The Puget Sound Water Quality Management Plan.....	1-6
1.6.2 Phase I – Ecology’s NPDES and State Waste Discharge Stormwater Permits for Municipalities.....	1-6
1.6.3 Phase II – Ecology’s NPDES and State Waste Discharge Stormwater Permits for Municipalities.....	1-7
1.6.4 Ecology’s State Waste Discharge Permits for Direct Discharges.....	1-7
1.6.5 Ecology’s Industrial Stormwater Permit (i.e. NPDES and State Waste Discharge Baseline General Permit for Stormwater Discharges Associated With Industrial Activities).....	1-8
1.6.6 Ecology’s Construction Stormwater Permit (i.e. NPDES and State Waste Discharge General Permit for Stormwater Discharges Associated With Construction Activity) .....	1-9
1.6.7 Endangered Species Act .....	1-9
1.6.8 Section 401 Water Quality Certifications .....	1-10
1.6.9 Hydraulic Project Approvals (HPAs).....	1-11
1.6.10 Aquatic Lands Use Authorizations.....	1-11

1.6.11	Requirements Identified through Watershed/Basin Planning or Total Maximum Daily Loads .....	1-11
1.6.12	Underground Injection Control Authorizations .....	1-12
1.6.13	Other City Requirements .....	1-12
1.7	Effects of Urbanization .....	1-13
1.7.1	Hydrologic Changes .....	1-13
1.7.2	Water Quality Changes.....	1-13
1.7.3	Biological Changes.....	1-14
<b>Chapter 2</b>	<b>– Tacoma’s Watersheds and Subwatersheds .....</b>	<b>2-1</b>
2.1	Introduction.....	2-1
2.2	Watershed Designations .....	2-1
2.3	Drainage Basin Planning.....	2-3
2.3.1	Basin and Watershed Plans .....	2-3
2.3.2	Larger Watershed Plans.....	2-3
2.3.2.1	Hylebos Creek and Lower Puget Sound Basin.....	2-4
2.3.2.2	Lower Puyallup Watershed Action Plan.....	2-4
2.3.2.3	Clover-Chambers Creek Watershed Management Plan .....	2-5
2.4	Land Use.....	2-5
2.4.1	Land Use Regulations .....	2-5
2.4.2	Land Use Plans .....	2-6
2.5	Impaired Waterbodies .....	2-7
2.6	Tacoma’s Watersheds.....	2-8
2.6.1	Flett Creek .....	2-8
2.6.1.1	Wapato Lake.....	2-9
2.6.1.2	Snake Lake.....	2-10
2.6.1.3	South Tacoma Ground Water Protection District.....	2-11
2.6.2	Leach Creek .....	2-11
2.6.2.1	Landfill Superfund Site.....	2-12
2.6.3	Northeast Tacoma .....	2-13
2.6.4	Joe’s Creek.....	2-14
2.6.5	North Tacoma .....	2-15
2.6.6	Thea Foss Waterway.....	2-16
2.6.7	Tideflats .....	2-18
2.6.7.1	Sitcum Waterway.....	2-19
2.6.7.2	Hylebos Waterway.....	2-19

2.6.7.3	Blair Waterway.....	2-20
2.6.7.4	Middle Waterway .....	2-20
2.6.8	T-Street/Lower Puyallup .....	2-20
2.6.8.1	Puyallup River.....	2-21
2.6.8.2	Swan Creek .....	2-22
2.6.8.3	T-Street Gulch .....	2-22
2.6.9	Western Slopes Watershed .....	2-23
2.7	Flow Control Requirements for Specific Watersheds .....	2-23
2.7.1	Overview.....	2-23
2.7.2	In-Lieu-Of Flow Control Policy .....	2-24
<b>Chapter 3 – Minimum Requirements for New Development and Redevelopment.....</b>		<b>3-1</b>
3.1	Relationship to Ecology’s 2001 Stormwater Management Manual and the Puget Sound Water Quality Management Plan.....	3-2
3.2	Exemptions.....	3-3
3.2.1	Forest Practices.....	3-3
3.2.2	Road Maintenance.....	3-3
3.2.3	Underground Utility Projects .....	3-4
3.2.4	Minor Clearing and Grading.....	3-4
3.2.5	Emergencies.....	3-5
3.3	Definitions Related to Minimum Requirements .....	3-5
3.4	Applicability of the Minimum Requirements.....	3-8
3.4.1	New Development .....	3-8
3.4.2	Redevelopment .....	3-9
3.5	Minimum Requirements .....	3-11
3.5.1	Minimum Requirement #1: Preparation of Stormwater Site Plans.....	3-12
3.5.2	Minimum Requirement #2: Construction Stormwater Pollution Prevention (SWPP).....	3-12
Element 1:	Mark Clearing Limits.....	3-13
Element 2:	Establish Construction Access .....	3-13
Element 3:	Control Flow Rates .....	3-13
Element 4:	Install Sediment Controls.....	3-14
Element 5:	Stabilize Soils .....	3-14
Element 6:	Protect Slopes .....	3-15
Element 7:	Protect Drain Inlets.....	3-16

Element 8: Stabilize Channels and Outlets .....	3-16
Element 9: Control Pollutants .....	3-16
Element 10: Control De-Watering.....	3-17
Element 11: Maintain BMPs .....	3-17
Element 12: Manage The Project .....	3-18
3.5.3 Minimum Requirement #3: Source Control of Pollution.....	3-20
3.5.4 Minimum Requirement #4: Preservation of Natural Drainage Systems and Outfalls.....	3-21
3.5.5 Minimum Requirement #5: On-Site Stormwater Management.....	3-22
3.5.6 Minimum Requirement #6: Runoff Treatment.....	3-24
3.5.7 Minimum Requirement #7: Flow Control .....	3-27
3.5.7.1 Applicability.....	3-27
3.5.7.2 Exemptions.....	3-27
3.5.7.3 Thresholds.....	3-28
3.5.7.4 Modeling Guidelines .....	3-28
3.5.8 Minimum Requirement #8: Wetlands Protection .....	3-30
3.5.9 Minimum Requirement #9: Basin/Watershed Planning .....	3-32
3.5.10 Minimum Requirement #10: Operation and Maintenance .....	3-32
3.6 Additional Requirements .....	3-33
3.6.1 Additional Requirement #1 – Off-Site Analysis and Mitigation .....	3-33
3.6.2 Additional Requirement #2: Financial Liability .....	3-36
3.7 Exceptions.....	3-37
<b>Chapter 4 – Preparation of Stormwater Site Plans .....</b>	<b>4-1</b>
4.1 Stormwater Site Plans: Step-By-Step.....	4-1
4.1.1 Step 1 – Collect and Analyze Information on Existing Conditions.....	4-2
4.1.2 Step 2 – Prepare Preliminary Development Layout.....	4-2
4.1.3 Step 3 – Perform an Offsite Analysis.....	4-3
4.1.4 Step 4 – Determine and Read the Applicable Minimum Requirements .....	4-3
4.1.5 Step 5 – Prepare a Permanent Stormwater Control Plan.....	4-3
4.1.6 Step 6 – Prepare a Construction Stormwater Pollution Prevention Plan .....	4-6
4.1.7 Step 7 – Complete the Stormwater Site Plan .....	4-7
4.1.8 Step 8 – Check Compliance with All Applicable Minimum Requirements .....	4-9

4.2	Plans Required After Stormwater Site Plan Approval .....	4-9
4.2.1	Stormwater Site Plan Changes.....	4-9
4.2.2	Final Corrected Plan Submittal.....	4-9
<b>Chapter 5 – BMP and Facility Selection Process for Permanent Stormwater</b>		
<b>Control Plans .....</b>		<b>5-1</b>
5.1	Purpose .....	5-1
5.2	BMP and Facility Selection Process.....	5-1
5.2.1	Step I – Determine and Read the Applicable Minimum Requirements.	5-1
5.2.2	Step II – Select Source Control BMPs.....	5-1
5.2.3	Step III – Determine Threshold Discharge Areas and Applicable Requirements for Treatment, Flow Control, and Wetlands Protection.	5-2
5.2.4	Step IV – Select Flow Control BMPs and Facilities .....	5-2
5.2.5	Step V – Select Treatment Facilities.....	5-3
5.2.6	Step VI – Review Selection of BMPs and Facilities.....	5-9
5.2.7	Step VII – Complete Development of Permanent Stormwater Control Plan .....	5-9
 <b>References.....</b>		<b>Ref-1</b>
 <b>Glossary and Notations.....</b>		<b>Glossary-1</b>
<b>Appendices</b>		
Appendix I-A	Guidance for Altering the Minimum Requirements Through Basin Planning	
Appendix I-B	Water Quality Treatment Design Storm, Volume, and Flow Rate	
Appendix I-C	Basic Treatment Receiving Waters	
Appendix I-D	Wetlands and Stormwater Management Guidelines	
Appendix I-E	Submittal Requirements Checklist	
Appendix I-F	Bond Quantities Worksheet	
Appendix I-G	Hydraulic Analysis Worksheet	

## Tables

2.7.1	Watershed Flow Control Requirements if Applicable Thresholds are Met per Minimum Requirement #7.....	2-25
2.7.2	In-Lieu-Of Flow Control .....	2-26
2.7.3	In-Lieu-Of Flow Control .....	2-27
3.1	Treatment Requirements by Threshold Discharge Area .....	3-39
3.2	Project Flow Control Requirements by Threshold Discharge Area .....	3-39
5.1	Suggested Stormwater Treatment Options for New Development and Redevelopment Projects .....	5-10
5.2	Ability of Treatment Facilities to Remove Key Pollutants .....	5-11
5.3	Screening Treatment Facilities Based on Soil Type.....	5-11

## Figures

2-1	City of Tacoma Watersheds .....	2-28
2-2	South Tacoma Groundwater Protection District Map .....	2-29
3-1	Threshold Discharge Areas.....	3-40
3-2	Flow Chart for Determining Requirements for New Development .....	3-41
3-3	Flow Chart for Determining Requirements for Redevelopment.....	3-42
3-4	Flow Chart for Determining Flow Control for New Development and Redevelopment within a Given Threshold Discharge Area.....	3-43
5-1	Treatment Facility Selection Flow Chart .....	5-12



# Acknowledgements

---

The development of this Surface Water Management Manual was made possible through the assistance and consultation of many people, not only those within the City, but those working for other agencies, engineering firms and those affiliated with environmental groups. The City of Tacoma would like to thank the following people for their time and expertise devoted to the development of this Manual.

In addition, the City would also like to specifically acknowledge the assistance of Sandra Kilroy of King County and Heather Kibbey of Pierce County in developing the information utilized in Volume IV, Source Control BMPs.

## City of Tacoma Surface Water Manual Team

John Burk (Project Manager)  
Dana De Leon  
Sandi Holdener  
Chris Johnson  
Lorna Mauren  
Anne Spangler  
Christy Strand

## City of Tacoma Public Works Department

### Administration

Karen Larkin  
Bill Pugh  
Craig Sivley  
John Stetson

### Building and Land Use Services Division

Karla Kluge  
Sue Martin  
Cap Pearson  
Gary Pedersen  
Pete Rambow

### Construction Division

Dan Handa  
Kris McColeman  
Tina Nelson  
Steve Nichols

### Engineering Division

James Coffman  
Mike Dalin  
JB Hur  
Chris Larson  
Dan Seabrand

### Science and Engineering Division

Ryan Flynn  
Spencer Keene  
Tim Sparling  
Catherine Taylor

**Name****Affiliation**

Tony Barrett	Washington State Department of Ecology
Stan Ciuba	Washington State Department of Ecology
Scott Hanson	Puget Creek Restoration Society
Larry Hires	Sitts and Hill Engineers, Inc.
Heather Kibbey	Pierce County
Sandra Kilroy	King County
Donna Lynch	Washington State Department of Ecology
Ed O'Brien	Washington State Department of Ecology
Heather Pennington	Tacoma Water
Anna Thurston	Tacoma Water
Cynthia Stonick	Washington State Department of Ecology
Kelly Whiting	King County

# **City of Tacoma Surface Water Management Manual**

---

## **Volume I Minimum Technical Requirements and Site Planning**

Prepared by:

Tacoma Public Works  
Environmental Services

January 2003



# Table of Contents – Volume I

---

<b>Acknowledgements .....</b>	<b>i</b>
<b>Chapter 1 – Introduction.....</b>	<b>1-1</b>
1.1 Objective.....	1-1
1.2 Relationship to Ecology’s Stormwater Manual .....	1-1
1.3 Organization of this Manual .....	1-2
1.3.1 Overview of Manual Content .....	1-2
1.3.2 Organization of this Manual.....	1-3
1.3.3 Organization of Volume 1 .....	1-3
1.4 How to Use this Manual .....	1-3
1.5 Development of Best Management Practices for Stormwater Management.....	1-4
1.5.1 Best Management Practices (BMPs) .....	1-4
1.5.2 Source Control BMPs .....	1-4
1.5.3 Treatment BMPs .....	1-4
1.5.4 Flow Control BMPs.....	1-5
1.6 Relationship of this Manual to Federal, State, and Local Regulatory Requirements .....	1-6
1.6.1 The Puget Sound Water Quality Management Plan .....	1-6
1.6.2 Phase I – Ecology’s NPDES and State Waste Discharge Stormwater Permits for Municipalities.....	1-6
1.6.3 Phase II – Ecology’s NPDES and State Waste Discharge Stormwater Permits for Municipalities.....	1-7
1.6.4 Ecology’s State Waste Discharge Permits for Direct Discharges.....	1-7
1.6.5 Ecology’s Industrial Stormwater Permit (i.e. NPDES and State Waste Discharge Baseline General Permit for Stormwater Discharges Associated With Industrial Activities) .....	1-8
1.6.6 Ecology’s Construction Stormwater Permit (i.e. NPDES and State Waste Discharge General Permit for Stormwater Discharges Associated With Construction Activity) .....	1-9
1.6.7 Endangered Species Act.....	1-9
1.6.8 Section 401 Water Quality Certifications.....	1-10
1.6.9 Hydraulic Project Approvals (HPAs) .....	1-11
1.6.10 Aquatic Lands Use Authorizations .....	1-11

1.6.11	Requirements Identified through Watershed/Basin Planning or Total Maximum Daily Loads .....	1-11
1.6.12	Underground Injection Control Authorizations .....	1-12
1.6.13	Other City Requirements .....	1-12
1.7	Effects of Urbanization .....	1-13
1.7.1	Hydrologic Changes .....	1-13
1.7.2	Water Quality Changes .....	1-13
1.7.3	Biological Changes.....	1-14
<b>Chapter 2 – Tacoma’s Watersheds and Subwatersheds.....</b>		<b>2-1</b>
2.1	Introduction .....	2-1
2.2	Watershed Designations .....	2-1
2.3	Drainage Basin Planning.....	2-3
2.3.1	Basin and Watershed Plans .....	2-3
2.3.2	Larger Watershed Plans.....	2-3
2.3.2.1	Hylebos Creek and Lower Puget Sound Basin .....	2-4
2.3.2.2	Lower Puyallup Watershed Action Plan .....	2-4
2.3.2.3	Clover-Chambers Creek Watershed Management Plan .....	2-5
2.4	Land Use .....	2-5
2.4.1	Land Use Regulations .....	2-5
2.4.2	Land Use Plans .....	2-6
2.5	Impaired Waterbodies.....	2-7
2.6	Tacoma’s Watersheds .....	2-8
2.6.1	Flett Creek.....	2-8
2.6.1.1	Wapato Lake .....	2-9
2.6.1.2	Snake Lake .....	2-10
2.6.1.3	South Tacoma Ground Water Protection District .....	2-11
2.6.2	Leach Creek.....	2-11
2.6.2.1	Landfill Superfund Site.....	2-12
2.6.3	Northeast Tacoma.....	2-13
2.6.4	Joe’s Creek .....	2-14
2.6.5	North Tacoma .....	2-15
2.6.6	Thea Foss Waterway.....	2-16
2.6.7	Tideflats.....	2-18
2.6.7.1	Sitcum Waterway.....	2-19
2.6.7.2	Hylebos Waterway.....	2-19

2.6.7.3	Blair Waterway .....	2-20
2.6.7.4	Middle Waterway .....	2-20
2.6.8	T-Street/Lower Puyallup .....	2-20
2.6.8.1	Puyallup River .....	2-21
2.6.8.2	Swan Creek .....	2-22
2.6.8.3	T-Street Gulch .....	2-22
2.6.9	Western Slopes Watershed .....	2-23
2.7	Flow Control Requirements for Specific Watersheds .....	2-23
2.7.1	Overview .....	2-23
2.7.2	In-Lieu-Of Flow Control Policy .....	2-24
<b>Chapter 3 – Minimum Requirements for New Development and Redevelopment.....</b>		<b>3-1</b>
3.1	Relationship to Ecology’s 2001 Stormwater Management Manual and the Puget Sound Water Quality Management Plan .....	3-2
3.2	Exemptions .....	3-3
3.2.1	Forest Practices .....	3-3
3.2.2	Road Maintenance .....	3-3
3.2.3	Underground Utility Projects .....	3-4
3.2.4	Minor Clearing and Grading.....	3-4
3.2.5	Emergencies .....	3-5
3.3	Definitions Related to Minimum Requirements.....	3-5
3.4	Applicability of the Minimum Requirements.....	3-8
3.4.1	New Development.....	3-8
3.4.2	Redevelopment .....	3-9
3.5	Minimum Requirements .....	3-11
3.5.1	Minimum Requirement #1: Preparation of Stormwater Site Plans .....	3-12
3.5.2	Minimum Requirement #2: Construction Stormwater Pollution Prevention (SWPP) .....	3-12
Element 1:	Mark Clearing Limits.....	3-13
Element 2:	Establish Construction Access.....	3-13
Element 3:	Control Flow Rates .....	3-13
Element 4:	Install Sediment Controls.....	3-14
Element 5:	Stabilize Soils .....	3-14
Element 6:	Protect Slopes .....	3-15
Element 7:	Protect Drain Inlets .....	3-16

Element 8: Stabilize Channels and Outlets.....	3-16
Element 9: Control Pollutants .....	3-16
Element 10: Control De-Watering .....	3-17
Element 11: Maintain BMPs .....	3-17
Element 12: Manage The Project .....	3-18
3.5.3 Minimum Requirement #3: Source Control of Pollution.....	3-20
3.5.4 Minimum Requirement #4: Preservation of Natural Drainage Systems and Outfalls.....	3-21
3.5.5 Minimum Requirement #5: On-Site Stormwater Management.....	3-22
3.5.6 Minimum Requirement #6: Runoff Treatment.....	3-24
3.5.7 Minimum Requirement #7: Flow Control.....	3-27
3.5.7.1 Applicability .....	3-27
3.5.7.2 Exemptions.....	3-27
3.5.7.3 Thresholds.....	3-28
3.5.7.4 Modeling Guidelines .....	3-28
3.5.8 Minimum Requirement #8: Wetlands Protection .....	3-30
3.5.9 Minimum Requirement #9: Basin/Watershed Planning .....	3-32
3.5.10 Minimum Requirement #10: Operation and Maintenance .....	3-32
3.6 Additional Requirements .....	3-33
3.6.1 Additional Requirement #1 – Off-Site Analysis and Mitigation .....	3-33
3.6.2 Additional Requirement #2: Financial Liability.....	3-36
3.7 Exceptions .....	3-37
<b>Chapter 4 – Preparation of Stormwater Site Plans .....</b>	<b>4-1</b>
4.1 Stormwater Site Plans: Step-By-Step.....	4-1
4.1.1 Step 1 – Collect and Analyze Information on Existing Conditions .....	4-2
4.1.2 Step 2 – Prepare Preliminary Development Layout .....	4-2
4.1.3 Step 3 – Perform an Offsite Analysis .....	4-3
4.1.4 Step 4 – Determine and Read the Applicable Minimum Requirements.....	4-3
4.1.5 Step 5 – Prepare a Permanent Stormwater Control Plan.....	4-3
4.1.6 Step 6 – Prepare a Construction Stormwater Pollution Prevention Plan.....	4-6
4.1.7 Step 7 – Complete the Stormwater Site Plan.....	4-7
4.1.8 Step 8 – Check Compliance with All Applicable Minimum Requirements.....	4-9



4.2	Plans Required After Stormwater Site Plan Approval.....	4-9
4.2.1	Stormwater Site Plan Changes.....	4-9
4.2.2	Final Corrected Plan Submittal.....	4-9
<b>Chapter 5 – BMP and Facility Selection Process for Permanent Stormwater</b>		
	<b>Control Plans .....</b>	<b>5-1</b>
5.1	Purpose .....	5-1
5.2	BMP and Facility Selection Process.....	5-1
5.2.1	Step I – Determine and Read the Applicable Minimum Requirements.	5-1
5.2.2	Step II – Select Source Control BMPs .....	5-1
5.2.3	Step III – Determine Threshold Discharge Areas and Applicable Requirements for Treatment, Flow Control, and Wetlands Protection..	5-2
5.2.4	Step IV – Select Flow Control BMPs and Facilities.....	5-2
5.2.5	Step V – Select Treatment Facilities.....	5-3
5.2.6	Step VI – Review Selection of BMPs and Facilities .....	5-9
5.2.7	Step VII – Complete Development of Permanent Stormwater Control Plan .....	5-9
	<b>References .....</b>	<b>Ref-1</b>
	<b>Glossary and Notations.....</b>	<b>Glossary-1</b>
<b>Appendices</b>		
Appendix I-A	Guidance for Altering the Minimum Requirements Through Basin Planning	
Appendix I-B	Water Quality Treatment Design Storm, Volume, and Flow Rate	
Appendix I-C	Basic Treatment Receiving Waters	
Appendix I-D	Wetlands and Stormwater Management Guidelines	
Appendix I-E	Submittal Requirements Checklist	
Appendix I-F	Bond Quantities Worksheet	
Appendix I-G	Hydraulic Analysis Worksheet	

## Tables

2.7.1	Watershed Flow Control Requirements if Applicable Thresholds are Met per Minimum Requirement #7 .....	2-25
2.7.2	In-Lieu-Of Flow Control .....	2-26
2.7.3	In-Lieu-Of Flow Control .....	2-27
3.1	Treatment Requirements by Threshold Discharge Area .....	3-39
3.2	Project Flow Control Requirements by Threshold Discharge Area.....	3-39
5.1	Suggested Stormwater Treatment Options for New Development and Redevelopment Projects .....	5-10
5.2	Ability of Treatment Facilities to Remove Key Pollutants .....	5-11
5.3	Screening Treatment Facilities Based on Soil Type.....	5-11

## Figures

2-1	City of Tacoma Watersheds .....	2-28
2-2	South Tacoma Groundwater Protection District Map .....	2-29
3-1	Threshold Discharge Areas .....	3-40
3-2	Flow Chart for Determining Requirements for New Development.....	3-41
3-3	Flow Chart for Determining Requirements for Redevelopment .....	3-42
3-4	Flow Chart for Determining Flow Control for New Development and Redevelopment within a Given Threshold Discharge Area .....	3-43
5-1	Treatment Facility Selection Flow Chart .....	5-12

# Acknowledgements

---

The development of this Surface Water Management Manual was made possible through the assistance and consultation of many people, not only those within the City, but those working for other agencies, engineering firms and those affiliated with environmental groups. The City of Tacoma would like to thank the following people for their time and expertise devoted to the development of this Manual.

In addition, the City would also like to specifically acknowledge the assistance of Sandra Kilroy of King County and Heather Kibbey of Pierce County in developing the information utilized in Volume IV, Source Control BMPs.

## City of Tacoma Surface Water Manual Team

John Burk (Project Manager)  
Dana De Leon  
Sandi Holdener  
Chris Johnson  
Lorna Mauren  
Anne Spangler  
Christy Strand

## City of Tacoma Public Works Department

### Administration

Karen Larkin  
Bill Pugh  
Craig Sivley  
John Stetson

### Building and Land Use Services Division

Karla Kluge  
Sue Martin  
Cap Pearson  
Gary Pedersen  
Pete Rambow

### Construction Division

Dan Handa  
Kris McColeman  
Tina Nelson  
Steve Nichols

### Engineering Division

James Coffman  
Mike Dalin  
JB Hur  
Chris Larson  
Dan Seabrand

### Science and Engineering Division

Ryan Flynn  
Spencer Keene  
Tim Sparling  
Catherine Taylor

**Name****Affiliation**

Tony Barrett	Washington State Department of Ecology
Stan Ciuba	Washington State Department of Ecology
Scott Hanson	Puget Creek Restoration Society
Larry Hires	Sitts and Hill Engineers, Inc.
Heather Kibbey	Pierce County
Sandra Kilroy	King County
Donna Lynch	Washington State Department of Ecology
Ed O'Brien	Washington State Department of Ecology
Heather Pennington	Tacoma Water
Anna Thurston	Tacoma Water
Cynthia Stonick	Washington State Department of Ecology
Kelly Whiting	King County

# Chapter 1 - Introduction

---

## 1.1 Objective

The objective of this manual is to provide guidance on the measures necessary to control the quantity and quality of stormwater produced by new development and redevelopment such that Ecology deems them to comply with water quality standards and contribute to the protection of beneficial uses of the receiving waters. The water quality standards include: Chapter 173-200 WAC, Water Quality Standards for Ground Waters of the State of Washington; Chapter 173-201A, Water Quality Standards for Surface Waters of the State of Washington; and Chapter 173-204, Sediment Management Standards.

This manual establishes minimum requirements for development and redevelopment projects of all sizes in the City of Tacoma and provides guidance concerning how to prepare and implement stormwater site plans. These requirements are, in turn, satisfied by the application of Best Management Practices (BMPs) from Volumes II through V. Projects that follow this approach will apply reasonable BMPs to reduce the adverse impacts of stormwater. This manual is applicable to all types of land development – including residential, commercial, industrial, and roads.

This manual can also be helpful in identifying options for retrofitting BMPs to existing development where appropriate.

In such situations, application of BMPs from this manual is encouraged. The City recognizes, however, that there can be site constraints that make the strict application of these BMPs difficult.

The primary purpose of using BMPs is to protect beneficial uses of water resources through the reduction of pollutant loads and concentrations, and through reduction of discharges (volumetric flow rates) causing stream channel erosion. If it is found that, after the implementation of BMPs advocated in this manual, beneficial uses are still threatened or impaired, then additional controls may be appropriate.

It is not the intent of this manual to make the City of Tacoma a guarantor or protector of public or private property with regard to land development activities.

## 1.2 Relationship to Ecology's Stormwater Manual

This manual is modeled after the Stormwater Management Manual for Western Washington, published by Ecology in August 2001. Ecology's stormwater manual was originally developed in response to a directive of the Puget Sound Water Quality Management Plan (PSWQA 1987 et seq.). The Puget Sound Water Quality Authority (since replaced by the Puget Sound Water Quality Action Team, PSWQAT) recognized the need

for overall guidance for stormwater quality improvement. It incorporated requirements in its plan to implement a cohesive, integrated stormwater management approach through the development and implementation of programs by local jurisdictions, and the development of rules, permits and guidance by Ecology.

The Puget Sound Water Quality Management Plan included a stormwater element (SW-3.1) requiring Ecology to develop a stormwater technical manual for use by local jurisdictions. Ecology's manual was originally developed to meet this requirement.

## 1.3 Organization of this Manual

### 1.3.1 Overview of Manual Content

To accomplish the objective described in Section 1.1, the manual includes the following:

- **Minimum Requirements** that cover a range of issues, such as preparation of Stormwater Site Plans, pollution prevention during the construction phase of a project, control of potential pollutant sources, treatment of runoff, control of stormwater flow volumes, protection of wetlands, and long-term operation and maintenance. The Minimum Requirements applicable to a project vary depending on the type and size of the proposed project.
- **Best Management Practices (BMPs)** that can be used to meet the minimum requirements. BMPs are defined as schedules of activities, prohibitions of practices, maintenance procedures, managerial practices, or structural features that prevent or reduce adverse impacts to waters of Washington State. BMPs are divided into those for short-term control of stormwater from construction sites, and those addressing long-term management of stormwater at developed sites. Long-term BMPs are further subdivided into those covering management of the volume and timing of stormwater flows, prevention of pollution from potential sources, and treatment of runoff to remove sediment and other pollutants.
- **Guidance on how to prepare and implement Stormwater Site Plans.** The Stormwater Site Plan is a comprehensive report that describes existing site conditions, explains development plans, examines potential offsite effects, identifies applicable Minimum Requirements, and proposes stormwater controls for both the construction phase and long-term stormwater management. The project proponent submits the Stormwater Site Plan to state and local permitting authorities with jurisdiction, who use the plan to evaluate a proposed project for compliance with stormwater requirements.

### **1.3.2 Organization of this Manual**

Volume I of this manual describes the geographical areas to which the manual applies, serves as an introduction and covers several key elements of developing the Stormwater Site Plan. The remaining volumes of this manual cover BMPs for specific aspects of stormwater management. Volumes II through V are organized as follows:

- Volume II covers BMPs for short-term stormwater management at construction sites;
- Volume III covers hydrologic analysis and BMPs to control flow volumes from developed sites;
- Volume IV addresses BMPs to minimize pollution generated by potential pollution sources at developed sites; and
- Volume V presents BMPs to treat runoff that contains sediment or other pollutants from developed sites.

### **1.3.3 Organization of Volume I**

Following this introduction, Volume I contains four additional chapters. Chapter 2 describes the geographic scope of this manual, and identifies the waterbodies and subbasins within the City of Tacoma, and the requirements that are specific to each. Chapter 3 identifies the Minimum Requirements for stormwater management at all new development and redevelopment projects. Chapter 4 describes the Stormwater Site Plan, and provides step-by-step guidance on how to develop this plan. Chapter 5 describes the process for selecting BMPs for long-term management of stormwater flows and quality. Appendices are included to support these topics. Volume I also includes the Glossary for all five volumes of the stormwater manual.

## **1.4 How to Use this Manual**

This manual is designed for a variety of users. Project proponents should start by reading Chapters 2 and 4 of Volume I. Chapter 2 identifies special requirements that may apply based on the location of the project. Chapter 4 explains how to complete stormwater site plans.

City staff will use this manual in reviewing Stormwater Site Plans, checking BMP designs, and providing technical advice to project proponents. City staff also will use this manual in designing public works projects. All development or redevelopment projects within the City of Tacoma shall meet the requirements of this manual unless specifically exempted by this manual or the Director.

The Director shall have the authority to modify requirements to protect the health, safety or welfare of the public on the basis of information regarding threatened water quality, erosion problems or potential habitat destruction, flooding, protection of uninterruptible services, or

endangerment to property. The Director also shall have the authority to modify requirements based upon increases in requirements imposed by state or federal agencies, where existing requirements are not applicable to the particular site, or other pertinent factors.

Where requirements in this manual are also mandated by any other law, ordinance, resolution, rule or regulation, the more restrictive requirement shall apply.

Permits may refer to this manual or the BMPs contained in this manual. In those cases, affected permit-holders or applicants should use this manual for specific guidance on how to comply with those permit conditions.

## **1.5 Development of Best Management Practices for Stormwater Management**

### **1.5.1 Best Management Practices (BMPs)**

The method by which the manual controls the adverse impacts of development and redevelopment is through the application of Best Management Practices.

Best Management Practices are defined as schedules of activities, prohibitions of practices, maintenance procedures, and structural and/or managerial practices, that when used singly or in combination, prevent or reduce the release of pollutants and other adverse impacts to waters of Washington State. The types of BMPs are source control, treatment, and flow control. BMPs that involve construction of engineered structures are often referred to as facilities in this manual. For instance, the BMPs referenced in the menus of Chapter 3 in Volume V are called treatment facilities.

### **1.5.2 Source Control BMPs**

Source control BMPs **prevent or reduce** pollution, or other adverse effects of stormwater, from occurring. In this manual, source control BMPs are classified as operational or structural. Examples of source control BMPs include methods as various as using mulches and covers on disturbed soil, putting roofs over outside storage areas, and berming areas to prevent stormwater run-on and pollutant runoff.

It is generally more cost effective to use source controls to **prevent** pollutants from entering runoff, than to treat runoff to remove pollutants.

### **1.5.3 Treatment BMPs**

Treatment BMPs include facilities that remove pollutants by simple gravity settling of particulate pollutants, filtration, biological uptake, and soil adsorption. Treatment BMPs can accomplish significant levels of pollutant load reductions if properly designed and maintained.



#### **1.5.4 Flow Control BMPs**

Flow control BMPs typically control the rate, frequency, and flow duration of stormwater surface runoff. The need to provide flow control BMPs depends on whether a development site discharges to a stream system or wetland, either directly or indirectly. Stream channel erosion control can be accomplished by BMPs that detain runoff flows and also by those which physically stabilize eroding streambanks. Both types of measures may be necessary. Only the former is covered in this manual.

Construction of a detention pond is the most common means of meeting flow control requirements. Construction of an infiltration facility is feasible only where more porous soils are available. The concept of detention is to collect runoff from a developed area and release it at a slower rate than it enters the collection system. The reduced release rate requires temporary storage of the excess amounts in a pond with release occurring over a few hours or days. The volume of storage needed is dependent on 1) the size of the drainage area; 2) the extent of disturbance of the natural vegetation, topography, and soils and creation of effective impervious surfaces (surfaces that drain to a stormwater collection system); and 3) how rapidly the water is allowed to leave the detention pond, i.e., the target release rates.

The 1992 Ecology manual focused primarily on controlling the peak flow release rates for recurrence intervals of concern – the 2, 10, and 100-year rates. Ecology believes this level of control does not adequately address the increased duration at which those high flows occur because of the increased volume of water from the developed condition as compared to the pre-developed conditions. To protect stream channels from increased erosion, it is necessary to control the durations over which a stream channel experiences geomorphically significant flows such that the energy imparted to the stream channel does not increase significantly. Geomorphically significant flows are those that are capable of moving sediments. Ecology's new target translates into lower release rates and significantly larger detention ponds than the previous Ecology standard. The size of such a facility can be reduced by changing the extent to which a site is disturbed.

In regard to wetlands, it is necessary to not alter the natural hydroperiod. This means control of flows from a development such that the wetland is within certain elevations at different times of the year and short-term elevation changes are within the prescribed limits. If the amount of surface water runoff draining to a wetland is increased because of land conversion from forested to impervious areas, it may be necessary to bypass some water around the wetland in the wet season. (Bypassed stormwater must still meet flow control and treatment requirements applicable to the receiving water.) If, however, the wetland was fed by local groundwater elevations during the dry season, the impervious surface additions and the bypassing practice may cause variations from the dry season elevations.

A continuous runoff model will be used to estimate what should be done to simulate the natural hydroperiod.

## **1.6 Relationship of this Manual to Federal, State, and Local Regulatory Requirements**

This manual is modeled after Ecology's Stormwater Management Manual for Western Washington. Ecology considers its manual to include all known, available and reasonable methods of prevention and treatment (AKART). Within Tacoma, Ecology's manual has no independent regulatory authority except where Ecology directly requires or issues permits. However, Ecology has reissued or shortly will reissue its General Permit for Discharges from Municipal Separate Storm Sewers, described in Section 1.6.2 below. Under federal regulations, Tacoma is required to obtain coverage under this permit, and the permit is expected to require the adoption of stormwater program components that are the substantial equivalent to the minimum requirements found in Ecology's 2001 manual. Upon adoption, Tacoma will use this manual in issuing permits and other authorizations for development. This section will explain the relationship of Tacoma's manual to each of the various programs, permits, and planning efforts described below.

### **1.6.1 The Puget Sound Water Quality Management Plan**

The Puget Sound Water Quality Management Plan (the Plan) is a voluntary plan that calls for every city and county in the Puget Sound Basin to develop and implement a comprehensive stormwater management program. The Plan recognizes that stormwater programs will vary among jurisdictions, depending on the jurisdiction's population, density, threats posed by stormwater, and results of watershed planning efforts. Under the Plan, cities and counties are encouraged to form intergovernmental cooperative agreements in order to pool resources and carry out program activities more efficiently. More information about what the Plan contains can be found in Chapter 1 of Ecology's Manual.

### **1.6.2 Phase I - Ecology's NPDES and State Waste Discharge Stormwater Permits for Municipalities**

Tacoma is subject to permitting under the U.S. Environmental Protection Agency (EPA) Phase I Stormwater Regulations (40 CFR Part 122) under the Clean Water Act NPDES provisions. In Washington State, administration of the NPDES program is delegated to the Department of Ecology. In Western Washington, Ecology has issued joint NPDES and State Waste Discharge permits to regulate the discharges of stormwater from the municipal separate storm sewer systems operated by large and medium sized municipal permittees.

As a condition (Special Condition S7.b.8.a.) of the permits issued in July 1995, these entities are required to implement stormwater programs that must include:

“...ordinances (except WSDOT’s program), minimum requirements and best management practices (BMPs) equivalent to those found in Volumes I-IV of Ecology’s *Stormwater Management Manual for the Puget Sound Basin* (1992 edition, and as amended by its replacement)...”

These entities had until the end of the permit terms, July 2000 to comply with this requirement.

Ecology has administratively extended these municipal permits until it can reissue updated permits. In the reissued permits, Ecology intends to include a special condition similar to the above with a reference to this updated stormwater manual. Ecology will also add a deadline or deadlines within the term of the permit for compliance with the condition.

The 1995 municipal stormwater permit also has a Special Condition that applies only to Tacoma that addresses discharges to the Thea Foss Waterway. The reissued permit will contain a similar, but updated Special Condition for the Thea Foss and Wheeler-Osgood Waterways.

Requirements arising out of Tacoma’s municipal stormwater permit are incorporated into this manual, including special requirements that apply in specific geographic areas.

### **1.6.3 Phase II - Ecology’s NPDES and State Waste Discharge Stormwater Permits for Municipalities**

The EPA adopted Phase II stormwater regulations in December 1999. Those rules identify additional municipalities as subject to NPDES municipal stormwater permitting requirements. An initial estimate is that 78 municipalities will be subject to the requirements, and 13 additional municipalities may be subject to the requirements, depending upon an analysis that Ecology must perform. In the vicinity of Tacoma, Phase II permits are expected to include the cities of Federal Way, Fife, Fircrest, Lakewood, Milton, Ruston and University Place. Ecology expects to issue the Phase II permits by December 2002. The proposed regulations specify minimum measures for the stormwater programs developed to comply with the Phase II permits

To at least partially fulfill Phase II permit requirements, Ecology intends to require the Phase II municipalities in Western Washington to adopt ordinances, minimum requirements, and BMPs equivalent to those in its 2001 manual. Essentially, this would be the same permit condition as currently required of the Phase I municipalities.

### **1.6.4 Ecology’s State Waste Discharge Permits for Direct Discharges**

The requirements imposed under the Phase I and II EPA Stormwater Regulations apply to discharges to Tacoma’s municipal stormwater system. However, the regulations do not apply to “direct discharges,” that

is, discharges that do not enter the City's system but go directly into receiving waters.

Direct discharges are subject to permitting under Ecology's State Waste Discharge Permit program in Chapter 90.48 RCW. As with businesses or construction sites that are subject to Ecology's Baseline General Permits described in the following sections, direct dischargers may be required to utilize Ecology's 2001 Stormwater Manual for Western Washington in designing and managing sites, or in preparing and implementing Stormwater Pollution Prevention Plans.

The City may conduct courtesy reviews of development plans that include such direct discharges, however, such review does not relieve the applicant from obtaining and complying with any other applicable approvals or permits required by other state, federal or local requirements.

#### **1.6.5 Ecology's Industrial Stormwater Permit (i.e. NPDES and State Waste Discharge Baseline General Permit for Stormwater Discharges Associated With Industrial Activities)**

Businesses subject to Ecology's Baseline General Permit for Stormwater Discharges Associated With Industrial Activities have to prepare and implement a Stormwater Pollution Prevention Plan in accordance with the terms of that permit. The permit issued in November 2000 requires a description and implementation of generic "operational BMPs" (the same category of BMPs referred to as operational source control BMPs in this manual), and "source control BMPs" (the same category of BMPs referred to as "structural source control" BMPs in this manual) from Volume IV of Ecology's Stormwater Management Manual for Western Washington (SWMM). Additionally, application of erosion and sediment control BMPs, flow control BMPs, and treatment BMPs from the SWMM and other published guidance is required if necessary to address an erosion, flow, or pollution problem.

The permit requires selection of BMPs from: "the most recent published edition of the SWMM, or other equivalent manuals, available at least 120 days before the selection of the BMPs is necessary." This language will likely be included in all future revisions of this permit so that new facilities and facilities implementing new BMPs are always using the most current guidance on managing stormwater.

In the unlikely event of a conflict between requirements based on Ecology's manual that are imposed on a business under the Industrial Stormwater Permit, and requirements based on Tacoma's manual proposed to be imposed under some other permit or authorization, Tacoma may consider compliance with Ecology's requirements sufficient to meet Tacoma's standards, unless Tacoma determines additional or different standards or requirements are necessary.

### **1.6.6 Ecology's Construction Stormwater Permit (i.e. NPDES and State Waste Discharge General Permit for Stormwater Discharges Associated With Construction Activity)**

Construction sites that will disturb five acres or more and will have a discharge of stormwater from the project site to surface water must apply for coverage under Ecology's construction stormwater permit. The permit requires application of stabilization and structural practices to reduce the potential for erosion and the discharge of sediments from the site. The stabilization and structural practices cited in the permit are similar to the minimum requirements for sedimentation and erosion control in Volume I of the SWMM. The permit also requires construction sites within the Puget Sound basin to "select from BMPs described in Volume II of the most recent edition of Ecology's Stormwater Management Manual (SWMM) that has been available at least 120 days prior to the BMP selection." Sites outside the basin are required to select BMPs from the manual, from the Erosion and Sediment Control Handbook, by Goldman et al, or to select other appropriate BMPs.

Ecology's permit also states that where Ecology has determined that the local government requirements for construction sites are at least as stringent as Ecology's, Ecology will accept compliance with the local requirements. Accordingly, projects subject to Tacoma's permitting authority that are also required to obtain coverage under Ecology's Construction Permit should be designed in accordance with Tacoma's manual.

The EPA Phase II stormwater regulations require construction sites of one acre and larger to apply for an NPDES permit, effective March 2003. There is greater flexibility on options for implementing coverage for sites under five acres. Ecology has not determined how it will implement coverage for these small construction sites, but any strategy will require implementation of those BMPs necessary to protect the beneficial uses of surface water.

### **1.6.7 Endangered Species Act**

With the listing of multiple species of salmon as threatened or endangered across much of Washington State, and the probability of more listings in the future, implementation of the requirements of the Endangered Species Act will have a dramatic effect on urban stormwater management. The manner in which that will occur is still evolving. Provisions of the Endangered Species Act that may apply directly to stormwater management include the Section 4(d) rules, Section 7 consultations, and Section 10 Habitat Conservation Plans (HCP).

Under Section 4(d) of the statute, the federal government issues regulations to provide for the conservation of the species. A 4(d) rule may require new development and redevelopment to comply with specific requirements. It remains to be seen whether the federal government will cite the requirements of Ecology's manual in a 4(d) rule.

Under Section 7 of the statute, all federal agencies must insure that any action they authorize, fund, or carry out is not likely to jeopardize the continued existence of any endangered or threatened species (or a species proposed for listing), nor result in the destruction or adverse modification of designated critical habitat. The responsibility for initially determining whether jeopardy is likely to occur rests with the "action" agency. If an action "may affect" a listed species, the "action" agency must consult with the National Marine Fisheries Service (NMFS), or the U.S. Fish and Wildlife Service (USFWS) depending on the species involved, to determine whether jeopardy is likely to occur. Where NMFS or USFWS believes that jeopardy would result, it must specify reasonable and prudent alternatives to the action that would avoid jeopardy if any such alternatives are available. If the "action" agency rejects these, the action cannot proceed. Ecology's and Tacoma's manuals may play a role in these jeopardy decisions and the alternatives cited to avoid jeopardy.

Under Section 10 of the ESA, through voluntary agreements with the federal government that provide protections to an endangered species, a non-federal applicant may commit an "incidental take" of individuals of that species as long as it is incidental to an otherwise lawful activity (such as developing land or building a road). This provision of the ESA may help resolve conflicts between development pressures and endangered species protection. A "Habitat Conservation Plan" (HCP) is an example of this type of agreement. Under an HCP, the applicant's plan must:

- Outline the impact that will likely result from the taking;
- List steps the applicant will take to minimize and mitigate such impacts, and funding available to implement such steps; and
- Include alternative actions the applicant considered and reasons alternative acts are not being used.

The federal government may grant a permit if it finds that the taking will be incidental; the applicant will minimize and mitigate impacts of taking; and the applicant will ensure that adequate funding for the conservation plan will be provided. The USFWS and NMFS may require additional measures as necessary or appropriate for purposes of the plan. Ecology's and Tacoma's manuals may play a key role in any proposed Habitat Conservation Plans.

### **1.6.8 Section 401 Water Quality Certifications**

For projects that require a fill or dredge permit under Section 404 of the Clean Water Act, Ecology must certify to the permitting agency, the U.S. Army Corps of Engineers, that the proposed project will not violate state water quality standards. In order to make such a determination, Ecology may do a more specific review of the potential impacts of a stormwater discharge from the construction phase of the project and from the completed project. As a result of that review, Ecology may condition its certification to require:

- Application of the minimum requirements and BMPs in Ecology’s manual; or
- Application of more stringent requirements.

### **1.6.9 Hydraulic Project Approvals (HPAs)**

Under Chapter 77.55 RCW, the Hydraulics Act, the Washington State Department of Fish and Wildlife has the authority to require actions when stormwater discharges related to a project would change the natural flow or bed of state waters. The implementing mechanism is the issuance of a Hydraulics Project Approval (HPA) permit. In exercising this authority, Fish and Wildlife may require:

- Compliance with the provisions of Ecology’s manual; or
- Application of more stringent requirements that they determine are necessary to meet their statutory obligations to protect fish and wildlife.

### **1.6.10 Aquatic Lands Use Authorizations**

The Department of Natural Resources (DNR), as the steward of public aquatic lands, may require a stormwater outfall to have a valid use authorization, and to avoid or mitigate resource impacts. Through its use authorizations, which are issued under authority of Chapter 79.90 through 96 RCW, and in accordance with Chapter 332-30 WAC, DNR may require:

- Compliance with the provisions of Ecology’s manual; or
- Application of more stringent requirements that they determine are necessary to meet their statutory obligations to protect the quality of the state’s aquatic lands.

### **1.6.11 Requirements Identified through Watershed/Basin Planning or Total Maximum Daily Loads**

A number of the requirements of this manual can be superseded or modified by the adoption of ordinances and rules to implement the recommendations of watershed plans or basin plans. Tacoma will be conducting ongoing planning processes to evaluate the need for more stringent or alternative requirements. Requirements or standards that Tacoma has already established for specific subareas within the city are described in Chapter 2 of this Volume. These requirements are based upon analyses and plans already developed and approved under Tacoma’s previous stormwater manual and permit. Any future geographic specific requirements or conditions will be added to Chapter 2 as they are developed.

A requirement of this manual can also be superseded or added to through the adoption of specific actions and requirements identified in a Waste Load Allocation or cleanup plan that implements a Total Maximum Daily Load (TMDL) approved by the EPA. However, it is likely at least some

requirements implementing TMDLs will incorporate the use of the BMPs in this manual. Again, future specific requirements identified as part of a water cleanup plan or waste load allocation implementing a TMDL will be added to Chapter 2 of this volume as they are adopted.

### **1.6.12 Underground Injection Control Authorizations**

To implement provisions of the federal Safe Drinking Water Act, Ecology has adopted rules (Chapter 173-218 WAC) for an underground injection control (UIC) program. Depending upon the manner in which it is accomplished, the discharge of stormwater into the ground can be classified as a Class V injection well. Federal UIC regulations, 40 CFR Part 144, were revised in 2000 to include subsurface distribution systems, drywells, catch basins, and similar devices that discharge to the ground. To date, Ecology's activity under this program has been primarily in regard to registering all UIC wells.

### **1.6.13 Other City Requirements**

Many of the minimum requirements described in this Manual that apply to new development and redevelopment are codified in Chapter 12.08 of the Tacoma Municipal Code (TMC), and are applied to a given project in the normal course of city permitting. Chapter 12.08 governs wastewater and surface water and gives the City its authority to regulate water quality control of surface waters, the stormwater system, and the sanitary sewer system. This Chapter also provides inspection authority, and enforcement authority for illegal discharges to the sewer system.

New development and redevelopment projects also may be subject to other city code requirements, depending upon the nature and location of the project. These code requirements may include, but are not limited to the subdivision and land use permit procedures in Chapters 13.04 and 13.05 TMC; excavation and grading in TMC Section 2.02.330; off-site improvements that include storm drainage in TMC Section 2.02.130; driveway control in Chapter 10.14; groundwater protection in Chapter 12.09 TMC; shoreline regulation in Chapter 13.10 TMC; and critical areas protection in Chapter 13.11 TMC.

Under the Growth Management Act, Chapter 36.70A RCW, the City has developed utilities and capital facilities plans to help ensure the provision of adequate utilities, including storm drainage. Depending upon the type of projects, new development and redevelopment may be required to contribute to the construction of facilities necessary to accommodate impacts created by that development.

The Building and Land Use Services Division of the Department of Public Works is responsible for all land use permitting activities, including permits for buildings, grading, paving, shoreline activities, critical areas, short plats, formal subdivisions, etc. The BLUS staff coordinates with the other divisions of Public Works to ensure that all potential issues related to the project are addressed.



Where a new development or redevelopment project involves a discharge to the City's municipal sewer system, approval must be obtained from the Environmental Services/Science and Engineering Division of the Public Works Department, which may include a Special Approved Discharge Permit.

## **1.7 Effects of Urbanization**

### **1.7.1 Hydrologic Changes**

As settlement occurs and the population grows, trees are logged and land is cleared for the addition of impervious surfaces such as rooftops, roads, parking lots, and sidewalks. Maintained landscapes that have much higher runoff characteristics typically replace the natural vegetation. The natural soil structure is also changed due to grading and compaction during construction. Roads are cut through slopes and low spots are filled. Drainage patterns are irrevocably altered. All of this can result in drastic changes in the natural hydrology, including:

- Increased volumetric flow rates of runoff;
- Increased volume of runoff;
- Decreased time for runoff to reach a natural receiving water;
- Reduced ground water recharge;
- Increased frequency and duration of high stream flows and wetlands inundation during and after wet weather;
- Reduced stream flows and wetlands water levels during the dry season; and
- Greater stream velocities.
- Adverse impacts on existing City infrastructure and capacity.

### **1.7.2 Water Quality Changes**

Urbanization also can cause an increase in the types and quantities of pollutants in surface and ground waters. Runoff from urban areas has been shown to contain many different types of pollutants, depending on the nature of the activities in those areas. The runoff from roads and highways can be contaminated with pollutants from vehicles. Oil and grease, polynuclear aromatic hydrocarbons (PAHs), lead, zinc, copper, cadmium, as well as sediments (soil particles) and road salts can be typical pollutants in road runoff. Runoff from industrial areas can contain many types of heavy metals, sediments, and a broad range of man-made organic pollutants, including phthalates, PAHs, and other petroleum hydrocarbons. Residential areas can contribute the same road-based pollutants to runoff, as well as herbicides, pesticides, nutrients (from fertilizers), bacteria and viruses (from animal waste). All of these contaminants can seriously impair beneficial uses of receiving waters.

Regardless of the eventual land use conversion, the sediment load produced by a construction site can turn the receiving waters turbid and be deposited over the natural sediments of the receiving water. The addition of sediment loads also impacts existing City systems, causing localized flooding and increases in the cost and frequency of maintenance.

Urbanization also can cause changes in water temperature. Heated stormwater from impervious surfaces and exposed treatment and detention ponds may discharge to streams with less riparian vegetation for shade. Urbanization also can reduce ground water recharge, which reduces sources of cool ground water inputs to streams. In winter, stream temperatures may lower due to loss of riparian cover. There is also concern that the replacement of warmer ground water inputs with colder surface runoff during colder periods may have biological impacts.

### **1.7.3 Biological Changes**

Hydrologic and water quality changes can result in changes to the biological systems that were supported by the natural hydrologic system. In particular, aquatic life is greatly affected by urbanization. Habitats are altered when a stream changes its physical configuration and substrate due to increased flows. Natural riffles, pools, gravel bars and other areas can be altered or destroyed. These and other alterations produce a habitat structure that is very different from the one in which the resident aquatic life evolved.

The biological communities in wetlands also can be severely impacted and altered by the hydrological changes. Relatively small changes in the natural water elevation fluctuations can cause dramatic shifts in vegetative and animal species composition.

# Chapter 2 - Tacoma's Watersheds and Subwatersheds

---

## 2.1 Introduction

This chapter identifies and describes the waterbodies, watersheds, basins and subbasins within the City of Tacoma and the requirements that are specific to each. Where requirements have been developed for a particular geographic area, these requirements shall be in addition to the minimum requirements found in Chapter 3 of this Manual, unless the text in this Chapter specifically indicates that the area-specific requirement supersedes or replaces a minimum requirement.

In the event additional requirements that apply to specific watersheds, basins or subbasins are developed through planning or regulatory action, they will be added to this chapter.

## 2.2 Watershed Designations

A watershed is a region that drains to the same river, river system or other body of water. This document will refer to two types of watersheds within the City of Tacoma. Water Resource Inventory Areas (WRIAs) and watersheds are defined as follows:

- **WRIAs ("y-ras")** - These are large watersheds based on geographic areas usually associated with large river systems. There are 62 of them which have been identified throughout the state by the Department of Ecology. Portions of three WRIAs are located in Tacoma.
- **Watersheds** – Nine smaller watersheds have been identified in Tacoma. Some of these watersheds are associated with stream systems and some of them are identified geographically. Many of these watersheds cross political boundaries and are shared by one or more of the municipalities surrounding Tacoma.

The City has identified the following (9) watershed areas.

- Flett Creek
- Leach Creek
- Joe's Creek
- Northeast Tacoma
- North Tacoma
- Thea Foss Waterway (Foss Waterway)
- Tidelands
- T-Street/Lower Puyallup
- Western Slopes

For a map of the watersheds, see Figure 2-1. The City shares watersheds with both Pierce and King Counties, and with various municipalities within these counties. With regard to terminology for smaller subdivisions within a watershed, the term “basin” correlates to an area draining to a particular outfall. A “sub-basin” is a portion of a basin and is defined by a change in land use or is geographically separated from the rest of the basin by branching of the stormwater infrastructure, or piping system. For example, the 237A outfall (located in the Thea Foss Waterway watershed) consists of a drainage basin. This basin is divided into three sub-basins; an industrial area, and two residential areas to the north and south of the industrial area.

The three WRIAs that include parts of Tacoma are:

- **Puyallup WRIA (#10)** - Tacoma contains the lower portion of the Puyallup WRIA. This WRIA extends up to Mt. Rainier and contains the rest of the Puyallup River and all of its tributaries, which include the Carbon and White Rivers. Tacoma’s portion of the Puyallup WRIA includes the central and eastern portions of the City, but it also contains areas that don’t drain directly to the Puyallup River, but discharge instead to Commencement Bay. The Northeast Tacoma, Tideflats, T-Street/Lower Puyallup and Foss watersheds and the eastern half of the North Tacoma watershed are located in the Puyallup WRIA.
- **Clover-Chambers WRIA (#12)** - Tacoma also contains a portion of the Clover-Chambers WRIA. The Clover-Chambers WRIA drains the central part of Pierce County. This WRIA drains the southwestern and western portions of Tacoma and an area along Ruston Way. Some of these areas don’t drain to the Clover-Chambers system, but instead discharge to the Narrows or to Commencement Bay. The Flett Creek, Leach Creek and Western Slopes watersheds and the western half of the North Tacoma watershed are located in the Clover-Chambers WRIA.
- **Duwamish-Green WRIA (#9)** - A very small portion of the Duwamish-Green WRIA is located in Tacoma. Most of this WRIA is located in King County. A very small part of the Joe’s Creek watershed is located in Northeast Tacoma and is in this WRIA. The creek flows into Federal Way and discharges into Puget Sound.

Most of the information in this document will refer to Tacoma’s watersheds and not to the WRIAs. The City has available several resources for watershed, basin, wetland and other information. These resources include the information that follows in the rest of this chapter.

## **2.3 Drainage Basin Planning**

### **2.3.1 Basin and Watershed Plans**

A major purpose of a basin or watershed plan is to investigate existing and historic conditions and determine whether specific conditions or requirements are appropriate for development within the watershed or basin. Such plans can also serve as a guide for capital spending and prioritizing public and private projects designed to improve water quality or water quantity management. Typically this planning requires plans on a smaller scale than the WRIA or large watershed level. Such plans are typically referred to as basin plans, but can also be watershed plans on a smaller scale than the WRIA.

Tacoma has developed a Capital Facilities Program that includes a section on Stormwater Management as part of its comprehensive planning under the Growth Management Act. The latest version is dated December 20, 1999, and covers 1999-2004. This Stormwater Management section sets levels of service for stormwater management, including detention and conveyance system analysis, including capacity. Where these standards and levels of service will permit a project to deviate from some of the Minimum Requirements set forth in this Manual, the allowable deviation and required analysis are contained in Section 2.6 and 2.7 of this Chapter. Future watershed and basin plans that include geographic-specific requirements will be added to this Chapter as they are developed and adopted.

Tacoma has completed mapping its wetlands. The information is now available to staff and to the development community on the City's website.

Tacoma also has completed a preliminary Urban Creek Assessment, which is available through the Environmental Services, Science and Engineering Division. This Assessment provides the information from which a project proponent can identify areas of existing erosion potential or erosion problems, and areas where there are existing water quality problems. However, please note that this Urban Creek Assessment is not a complete listing of all erosion and water quality problems. This information is required of project applicants under the Minimum Requirements described in Chapter 3 of this Volume. As the information in the Urban Creek Assessment is updated, it also will be added to this Chapter.

### **2.3.2 Larger Watershed Plans**

The following watershed plans are on a large scale, often a WRIA level scale. They are typically broad in scope and recommend programmatic level actions rather than focusing on recommendations that might apply to an individual project level. The information in this section is provided for informational purposes.

### **2.3.2.1 - Hylebos Creek and Lower Puget Sound Basin**

The Hylebos Creek and Lower Puget Sound Basin Plan identifies basins which drain over 36 square miles of southwest King County and northwest Pierce County. Within Tacoma, this includes the Northeast Tacoma Watershed, Joe's Creek Watershed, and parts of the Tideflats Watershed. This plan was a joint project conducted by the City of Tacoma, King County, the Cities of Federal Way, Des Moines, Kent, Milton, Seattle, the Muckleshoot and Puyallup Tribes, the Federal Way Water and Sewer District, and various Washington State agencies to study part of WRIA 9. The Plan assessed the current condition of the aquatic system in each of these two basins and predicted future changes based on development patterns. It recommends a variety of management tools that, when fully implemented, will result in long-term stability and protection of significant beneficial uses in the aquatic systems. The Plan is a blueprint for immediate actions needed to reduce flooding, erosion, and sedimentation to improve water quality.

The Plan was completed in 1991 and a copy can be reviewed at the City's Environmental Services, Science and Engineering Division.

### **2.3.2.2 - Lower Puyallup Watershed Action Plan**

The Lower Puyallup Watershed Action Plan is another WRIA level plan that was developed by the Lower Puyallup Watershed Management Committee to cover the lower half of WRIA 10. The members of the Committee represented many interests and affected parties within the watershed including Native American tribes, environmental groups, fishing groups, local governments, public utilities, a conservation district, Washington State Department of Fisheries, businesses and farmers. The goal of the Committee was to solve problems of nonpoint water pollution in the Puyallup River Drainage Basin which includes the Northeast Tacoma Watershed, the Tideflats Watershed, the T-Street/Lower Puyallup Watershed, the Thea Foss Watershed and a portion of the North Tacoma Watershed. Action Plan development consisted of a three step process: The Phase I document (March 1992) describes the watershed, assesses current watershed conditions including conditions within watersheds, lists current water quality programs, and provides problem definitions. The report was subsequently adopted as an element of the Watershed Action Plan. In Phase II, the Watershed Committee developed source control action items and an implementation program. This resulted in the release of the Lower Puyallup Draft Watershed Action Plan in January 1993. Finally, in Phase III, local governments and private groups have reviewed and commented on the draft plan. Also, each implementing agency was requested to submit a statement of concurrence indicating its intent to adopt specific action items and implementing strategies. The City of Tacoma submitted a letter of concurrence on June 13, 1994.

A copy of the Phase I and Phase II documents can be reviewed at the City's Environmental Services, Science and Engineering Division.

### **2.3.2.3 - Clover-Chambers Creek Watershed Management Plan**

Tacoma was also involved with Pierce County in the development of the Clover-Chambers Creek Watershed Management Plan formerly known as the Tacoma Cluster Watershed Action Plan. The Pierce County Council formally established a committee to develop the plan on March 1, 1994. The plan includes a characterization of the existing physical conditions, problem definitions, goal statements, objectives and finally, individual action items. Six subcommittees were formed to work on specific topics: boats and marinas, education, stormwater and erosion, agriculture and forestry, on-site sewage and a miscellaneous or other category. The final draft of the watershed characterization and the watershed action plan were completed in March 1996. The City submitted a letter of concurrence on August 25, 1997. Plan implementation should result in improved water quality in the watershed.

The watershed includes areas that drain into Clover, Leach and Flett Creeks and then ultimately discharge into Puget Sound through Chambers Creek. It also includes areas which drain directly into the Puget Sound. The Plan area within the City of Tacoma includes the Western Slopes Watershed, the Leach Creek Watershed, the Flett Creek Watershed, and a portion of the North Tacoma Watershed.

In addition to the Tacoma Landfill, which is a Superfund site, this basin contains the South Tacoma Fields Superfund site.

The final draft of the 1996 Plan can be reviewed at the City's Environmental Services, Science and Engineering Division.

## **2.4 Land Use**

One of the factors determining the need for, and type of, area-specific controls, is the existing level of development and the types of land uses within a particular basin. Most of Tacoma is a highly urbanized environment. Within the City of Tacoma, a majority of the available land has been subjected to some level of development. All of these areas experiencing development are creating increased amounts of impervious surface. Areas in Northeast Tacoma and areas in the south end between 84th and 96th and on the East side are experiencing single family dwelling growth. Multi-family development is happening throughout the City. The areas in the downtown Tacoma area, in the tideflats and along South Tacoma Way are experiencing increasing amounts of development and redevelopment.

### **2.4.1. Land Use Regulations**

In accordance with the Growth Management Act, the City has developed a comprehensive planning effort which includes the adoption of comprehensive land use plans and consistent regulations for implementation. Regulations adopted consistent with the Growth

Management Act and Shoreline Management Act, as well as zoning, influence what development and redevelopment will be allowed in specific areas. Zoning regulations limit land use types and densities. Growth Management Act regulations include land use designations and protections such as wetlands and other critical areas, groundwater protection areas, and other resource lands. The City's Building Code also prescribes parameters that affect: the design of new development and redevelopment; what off-site improvements may be permitted; and excavation, grading, and erosion and sediment control requirements for a given site. Tacoma's Building and Land Use Services Department maintains a City Generalized Land Use Map, and other resources from which these designations and regulations can be obtained.

## 2.4.2 Land Use Plans

The comprehensive plans developed under GMA address, at a minimum, land use, transportation, housing, capital facilities and utilities. Tacoma has developed a Utilities Plan and a Capital Facilities Program to address utilities and their relationship to the adequate provision of services for existing and future land uses. These documents focus on the provision of adequate utilities, including storm drainage, provided City-wide and within the City's Urban Growth Boundaries. The Capital Facilities Program demonstrates how the stormwater projects to be developed over the next six years provide the required amount of capacity at the adopted level of service standard to meet the needs of the existing population and projected growth.

With respect to storm water regulations/issues, the following three policies have been included in the Utility Plan to assist in achieving the City's public facility and service provision goals:

- **LID/Development** - Street pavement LIDs constructed for existing residential developments may receive Utility funding for all or part of the required drainage facilities. Commercial, industrial and new residential developments must provide drainage facilities to City standards at no cost to the Utility. Once constructed, the Utility will take over operation and maintenance responsibilities for the public portion of the system.
- **Jurisdiction Agreements** - The development of agreements with adjacent jurisdictions are encouraged to determine the responsibilities each would have for stormwater management particularly in light of the stormwater National Pollutant Discharge Elimination System (NPDES) program and requirements.
- **Stormwater** - The Stormwater Management Program is to be developed to comply with NPDES requirements.

The City also has developed Environmental Policies as part of its GMA comprehensive planning process. The City has adopted a Critical Areas and Natural Resource Lands Element as part of its Environmental Policy Plan. In addition to generalized goals to provide an aesthetic and



healthful environment and to ensure conservation, protection, enhancement and proper management of natural resources, this Element specifies a number of more specific policies with respect to natural features of the environment, growth and development, pollution, recreation and open space, energy, land use, air quality water quality, scenic areas, solid waste recycling and environmental remediation.

Among the specific policies related to water quality and stormwater are the following:

- **Water Pollution** - Recognize the need for an increase in the level of sewage treatment and the eventual treatment of stormwater in order to meet future water pollution standards.
- **Retain Vegetation Near Water** - Encourage the retention of natural vegetation along lakes, ponds, and streams, where appropriate, in order to help preserve water quality, protect fishery resources and control erosion and runoff.
- **Shoreline** - Encourage cooperation between public and private efforts in the management and development of Tacoma's shorelines.
- **On-site Detention Facilities** - Encourage the use of on-site flow control (detention) facilities and filtration systems that are designed in conjunction with the city's storm drainage system, as may be appropriate or necessary, for all development located within identified critical drainage areas; or within areas where drainage problems would occur as a result of the proposed development.
- **Natural Watercourses** - Prohibit any filling of natural watercourses without adequate provisions for modifying the natural channel to meet drainage standards established by the City.
- **Natural Land Features and Erosion** - Protect existing natural gulches, watercourses, ravines, and similar land features from the adverse erosional effects of increased storm water runoff that is generated by new development.

In addition, the Element includes specific policies related to each of the various critical areas, including wetlands and stream corridors, fish and wildlife habitat conservation areas, aquifer recharge areas, flood hazard areas, erosion hazard areas, landslide hazard areas, seismic hazard areas and mineral resource lands.

## 2.5 Impaired Waterbodies

Section 305(b) of the Federal Clean Water Act (CWA) requires Ecology to prepare a report every two years on the status of the overall condition of the state's waters. The 1998 Water Quality Assessment (DOE 1998)

gives a general overview of water quality on a statewide basis. Tacoma is located in the Puget Lowlands ecoregion.

Section 303(d) of the CWA requires Ecology to prepare a list every two years containing waterbodies not expected to meet state surface water quality standards after implementation of technology-based controls. The State is then required to complete a Total Maximum Daily Load (TMDL) for all waters on that list. There are a number of waterbodies currently on Ecology's list for which no TMDL has yet been developed. The latest final list is dated 1998, however, Ecology is currently revising the 303(d) list, and expects to complete a new list in 2002. The existing list and other related information is available on Ecology's website.

Unless there is a project-specific requirement adopted as part of a Waste Load Allocation or other specific plan that implements a TMDL, and an appropriate treatment technology exists, these listings are unlikely to affect a given project.

## **2.6 Tacoma's Watersheds**

### **2.6.1 Flett Creek**

This watershed is 7,153 acres and is the second largest watershed in the City. The area is predominately residential with commercial and light industrial uses in localized areas. The watershed is bordered by Foss Watershed on the east, Leach Creek Watershed on the west and Pierce County to the south. This watershed includes Snake Lake, Wapato Lake, portions of Interstate 5, the South Tacoma Groundwater Protection District and the South Tacoma Field Superfund Site. A portion of the Tacoma Landfill Superfund site is also included in this watershed. For information regarding the Landfill Superfund site, see the description under Leach Creek Watershed below.

The entire Flett Creek Basin drains through a series of holding basins. This includes: Hosmer holding basin (near South 84<sup>th</sup> Street on the east side of I-5); Ward's Lake (directly across Interstate 5 from Hosmer); "Gravel Pit" holding basin (just north of Ward's Lake); and the four Flett Creek holding basins (located to the west in the vicinity of South 85th and Tyler Streets).

In addition to Tacoma's flow contribution, approximately 800 acres of Pierce County flows into the Hosmer holding basin. A small tributary area of Lakewood flows into Wards Lake (which contains fish), and WSDOT has a direct discharge to the lake. All runoff in this basin eventually flows through the four Flett Creek holding ponds. The runoff from the Snake Lake basin goes directly to the Flett Creek holding basins and does not go through the Hosmer system. A pump station located at the last Flett Creek holding pond pumps stormwater to the Flett Dairy wetlands and then it goes into Flett Creek.

Flett Creek is approximately 3.0 miles long and is located in the City of Lakewood. The northern portion of the stream is located in Tacoma but was ditched and/or piped long ago. A portion of the ditched/piped system flows through the South Tacoma Channel Superfund site. The lower portion of the creek in the City of Lakewood provides for salmonid spawning. The creek flows into Chambers Creek, which is also a salmonid bearing stream, which discharges to the Narrows Passage. There are two salmon hatcheries on Chambers Creek.

Significant flooding has occurred in the Hosmer/Wards Lake/Gravel Pit area during major "Act of God" rainfall events. As part of Tacoma's Capital Improvement Program, the capacity of the Hosmer Holding Basin was increased in 2001-2002 to reduce flooding in this area. Tacoma worked with the City of Lakewood, Pierce County, and the Washington State Department of Transportation on this project.

**Flow Control: Flow control (detention) is required for those sites that meet the threshold for flow control. In this watershed, at the option of the applicant, a contribution to a City fund may instead be made to upgrade the existing regional stormwater system. If the applicant chooses to make the contribution, an engineering analysis of the downstream drainage system must be done. The analysis must demonstrate that there is adequate capacity in the stormwater system within ¼ mile downstream of the project site. If capacity is available, the applicant can pay the contribution and connect to the system without providing flow control. If the analysis indicates that there is *not* capacity downstream, the applicant has the option of improving the system and then paying the in-lieu-of contribution, or providing flow control. If the applicant does not improve the system and flow control is required, no contribution can be made. Please refer to Section 2.7 for more information about capacity analysis and the City's in-lieu-of-detention fee policy.**

**Water Quality: Based upon the extensive set of improvements, ponds, and holding basins the City has established for this watershed, projects that discharge to this system shall use "basic" treatment but need not apply "enhanced" treatment.**

#### **2.6.1.1 - Wapato Lake**

Wapato Lake is a 30-acre urban lake and is the central feature of Wapato Park. This park is an 80-acre facility owned by Metro Parks Tacoma. Its valued uses include recreation (fishing and swimming), wildlife habitat and flood control. It is used by 50,000 to 60,000 visitors per year and is stocked with trout each spring for children's fishing. But for the stocking, it is unlikely the lake would support fish. The surrounding land uses are predominantly residential but include some commercial uses and portions of Interstate 5. Historically, aquatic weed growth, algae blooms, siltation, waterfowl related "swimmers' itch" and other problems have limited the recreational enjoyment of the lake.

Two major drainage basins (approximately 1,000 acres total), including stormwater from Interstate 5 discharge into the lake. The outlet at the south end of the lake is piped to the Ward's Lake holding basin.

Due to water quality problems in the past, a major restoration project took place in 1981, which included the drawdown of the lake, construction of an earthen dike between the north and south portions of the lake, dredging and treatment of the lake with aluminum sulfate for phosphorus control.

**Flow Control: Please refer to the above flow control information for Flett Creek.**

**Water Quality: Please refer to the above water quality information for Flett Creek.**

### **2.6.1.2 - Snake Lake**

Snake Lake is a 17-acre urban lake and wetland. It is the central feature of the Tacoma Nature Center, a 54-acre facility dedicated to nature education, research and appreciation, operated by Metro Parks Tacoma. Approximately 100,000 people visit this Center each year. Valued recreational uses include walking the trails and viewing wildlife. The lake does not support fishing or swimming. Local high schools have been involved in water quality sampling and educational efforts associated with this lake/facility. Also, watershed signs have been posted and catch basins have been stenciled in the associated drainage basin. The City is currently conducting water quality monitoring and public educational programs in this basin.

The lake drains an urban residential watershed of approximately 584 acres and the associated urban stormwater contributes approximately 80% of the annual flow. Large impervious areas in this drainage basin include Cheney Stadium, Foss High School and a Fred Meyer shopping center.

Snake Lake sustains large seasonal fluctuations in its surface area from 17 acres during wet weather to less than 4 acres during the summer. The area around the main stormwater inlet at the north end of the lake is accumulating sediment. Another stormwater inlet located towards the south end of the lake has an outlet at the south end. The water from Snake Lake discharges to the Flett Creek holding basins.

Also located in this drainage basin (northeast of Snake Lake) is the Delong Pond wetland. It currently is an isolated waterbody (in the past it did have a pumped outlet to the storm drainage system). It drains a small tributary area in the basin. Recently, the Pierce County Conservations Futures Program purchased part of the wetland and buffer to be preserved as wildlife habitat and open space.

**Flow Control: Please refer to the above flow control information for Flett Creek.**

**Water Quality: Please refer to the above water quality information for Flett Creek.**

### ***2.6.1.3 - South Tacoma Ground Water Protection District***

In 1985, the City of Tacoma adopted the South Tacoma Plan which formally designates the South Tacoma Groundwater Protection District (STGPD) as an “environmentally sensitive” area. See Figure 2-2 for delineation of the District. The plan specifically listed several action steps designed to protect the South Tacoma Aquifer. One of the steps mandated that a local groundwater protection program be developed for the STGPD. The ordinance is set out in City Code Chapter 13.09.010 through 13.09.200.

The focus of the STGPD program is prevention. It regulates existing and new underground and above ground tanks that store hazardous substances. The purpose of the program is to stop potential pollution problems before they create serious environmental contamination. This program is administered by the Tacoma-Pierce County Health Department (TPCHD) in coordination with Tacoma Water and the Fire Department. TPCHD is responsible for reviewing, authorizing, and issuing permits for business and industrial operations that are regulated under the program. Staff also perform site inspections. However, the Tacoma Public Works Department is responsible for the review and approval of all stormwater and sanitary sewer plans. Private infiltration systems used in the STGPD that receive stormwater from any street or paved parking area are prohibited, unless in the opinion of the Public Works Department, no other reasonable alternative exists. In such a case, the Director of Public Works may approve a private disposal system subject to acceptable design meeting all water quality requirements.

The City has also recently completed the development of a “model” well head protection program which focuses on the STGPD. Please contact Tacoma Water for more information about this program.

### **2.6.2 Leach Creek**

Tacoma’s portion of this watershed covers 1,728 acres and is comprised of residential and commercial land uses. It is located in the west-central section of Tacoma and is bordered by the Western Slopes and North Tacoma Watersheds to the north, the Flett Creek Watershed to the east, and the Cities of Fircrest and University Place to the west. Included in this watershed is a portion of Westgate Shopping Center, James Center, Highland Hills Shopping Center, and Tacoma Community College. A portion of the Tacoma Landfill Superfund site is also included in this watershed. China Lake is also a part of the watershed.

Stormwater within the watershed is piped to the Leach Creek Holding Basin, which discharges into Leach Creek, a highly urbanized stream. The cities of Tacoma and Fircrest discharge to the holding basin.

Leach Creek is a little over 2 miles long. Salmonid spawning habitat can be found from Chambers Creek up to Bridgeport Way (the lower portion of the Creek). The upper portions of the Creek also have pockets of spawning grounds; however, the elimination of vegetation and channelization by streamside homeowners and erosion during storm events have impacted these areas. Leach Creek flows into Chambers Creek just downstream of the confluence of Flett and Chambers Creek. Chambers Creek is a fish bearing creek and there are two fish hatcheries located on the creek.

The Leach Creek Holding Basin was constructed by the City of Tacoma in 1961. In 1991, the City completed major improvements to the Leach Creek Holding Basin. Now, during heavy rainfall events, stormwater is pumped from the holding basin into one of the Thea Foss drainage basins. The City also augments the flow in the Creek during periods of low flow as part of current Landfill remediation efforts. (This is explained in more detail below in the Landfill Superfund Site section.)

**Flow Control: Flow control (detention) is required for those sites that meet the threshold for flow control. In this watershed, at the option of the applicant, a contribution to a City fund may instead be made to upgrade the existing regional/city stormwater system. If the applicant chooses to make the contribution, an engineering analysis of the downstream drainage system must be done. The analysis must demonstrate that there is adequate capacity in the stormwater system within ¼ mile downstream of the project site. If capacity is available, the applicant can pay the contribution and connect to the system without providing flow control. If the analysis indicates that there is *not* capacity downstream, the applicant has the option of improving the system and then paying the in-lieu-of contribution, or providing flow control. If the applicant does not improve the system and flow control is required, no contribution can be made. Please refer to Section 2.7 for more information about capacity analysis and the City's in-lieu-of-detention fee policy.**

**Water Quality: Based upon the pond and holding basin the City has established for this watershed, projects that discharge to this system shall use “basic” treatment but need not apply “enhanced” treatment.**

#### **2.6.2.1 - Landfill Superfund Site**

The Solid Waste Management Division of the City of Tacoma-Public Works Department operates the Tacoma Landfill which is located near Tacoma's border with the City of Fircrest.

The Tacoma Landfill was placed on the National Priorities List of hazardous waste sites as part of the South Tacoma Channel Superfund Site. The City prepared a Remedial Investigation and Feasibility Study in December 1987. On March 31, 1988, EPA issued the Record of Decision (ROD) for the Tacoma Landfill which presented the selected remedial actions. This included landfill capping and constraints on site operations; installation of a groundwater extraction/treatment system; elimination of offsite landfill gas migration through operation of an existing gas extraction/flare system; environmental monitoring including groundwater, surface water, and air emissions; and provision of an alternate water supply to any resident deprived of their domestic supply through contamination emanating from the landfill or as a result of operation of the extraction system. The City then entered into a Consent Decree with Ecology and EPA in 1989, which implemented the cleanup activities described in the ROD. The remedial work at the site is complete, however the Consent Decree and related documents continue to govern some of the ongoing operations at the site, as well as the allowable land uses for the site.

The City has an extensive ongoing groundwater and surface water quality monitoring plan in place at the site. Any project that is in the vicinity of the Landfill must be scrutinized for possible impacts to surface water or groundwater that might interfere with or affect operations at the Landfill.

In addition, the City of Tacoma has signed a Memorandum of Understanding with the Department of Ecology to augment flows in Leach Creek. The purpose for augmenting the flow is to mitigate for loss in base flow resulting from extraction well pumping along the eastern bank of the creek. The City installed in the sea level aquifer a well to be used as the clean water source for augmenting the flows in Leach Creek. The well is located adjacent to the Leach Creek Holding Basin pump station.

### **2.6.3 Northeast Tacoma**

This watershed covers 2,641 acres and consists primarily of residential land uses with open spaces and undeveloped land. Recently, this portion of Tacoma has been the fastest growing area of the City of Tacoma with the development of many large residential plats along with some supportive commercial uses such as grocery store complexes. The area borders Commencement Bay and the Tideflats Watershed on the west. Many steep bluffs are located between the uplands areas and Commencement Bay and the Hylebos Waterway. Pierce County and the City of Federal Way border the area to the north and east and the City of Fife is located to the south.

Most of the stormwater from this watershed is discharged directly to Commencement Bay or to the Hylebos Waterway. Some stormwater is discharged to Dry Gulch, an intermittent stream that discharges to Puget Sound through unincorporated Pierce County. A capital improvement project was completed in Dry Gulch in 1993 to control flooding and associated erosion and sediment problems. Stormwater is discharged to

other gulch systems as well. None of the stormwater discharges in this area are to fish bearing streams.

**Flow Control:** Flow control (detention) is required for all projects that meet the minimum threshold for flow control and that discharge directly or indirectly to a creek or gulch system, in accordance with Minimum Requirement #7: Therefore, for these projects, there are no specific geographic flow control requirements in this watershed.

Sites that meet the minimum threshold for flow control, but do not discharge to a creek or gulch system, but are instead piped all the way to a marine outfall, are required to do an offsite analysis for capacity. The analysis must demonstrate that there is adequate capacity in the stormwater system within ¼ mile downstream of the project site. If capacity is available, the applicant can connect to the system without providing flow control. If the analysis indicates that there is not capacity downstream, the applicant has the option of improving the system or providing flow control.

**Water Quality:** Projects that discharge to a natural resources restoration site shall be required to apply enhanced treatment for water quality.

#### 2.6.4 Joe's Creek

This watershed covers 157 acres and is the smallest of the City's five watersheds. It is bordered on the north and east by Pierce County and the City of Federal Way, respectively. The area is comprised of single and multiple-family residential land uses with some open space and undeveloped land. Most of Joe's Creek is located in Federal Way. Drainage in this area discharges to Federal Way and eventually to Puget Sound at Dumas Bay. Joe's Creek is utilized by salmonids.

Flow increases are expected in only a few areas that are not currently developed, including upper Joe's Creek in the City of Tacoma. The City of Tacoma recently constructed a detention pond on the Northshore Golf Course to mitigate the effect of development and to address flooding problems. Almost all of the drainage in this area flows through this regional detention pond.

**Flow Control:** Flow control (detention) is required for all projects that meet the minimum threshold for flow control and that discharge *directly* to Joe's Creek in accordance with Minimum Requirement #7: Therefore, for these projects, there are no specific geographic flow control requirements in this watershed.

Sites that meet the minimum threshold for flow control, but do not discharge directly to Joe's Creek are not required to do flow control, but are required to do an offsite analysis for capacity. The analysis must demonstrate that there is adequate capacity in the stormwater system within ¼ mile downstream of the project site. If capacity is



**available, the applicant can connect to the system without providing flow control. If the analysis indicates that there is not capacity downstream, the applicant has the option of improving the system or providing flow control.**

**Water Quality: Projects that discharge to the City of Tacoma's detention pond shall not be required to apply enhanced treatment.**

### **2.6.5 North Tacoma**

This watershed covers 4,766 acres and is located in the northern portion of Tacoma. The area includes the east side of Point Defiance Park extending to North 30th and Pearl Street, and the area from approximately 6th Avenue and Stevens Street to Commencement Bay. The area is predominately residential in nature with some commercial areas such as 6th Avenue, Proctor District, a portion of Westgate Shopping Center, and Ruston Way. It also contains the North End Wastewater Treatment Plant and the former ASARCO smelting site. The nearshore area along Commencement Bay north to the former ASARCO copper smelting site has been designated as part of the Commencement Bay Nearshore/Tideflats Superfund Site. Steep slopes are located along the northern edge of the watershed.

Waterbodies within this watershed include Commencement Bay, Ruston Creek, Asarco Creek, Puget Creek, Mason Creek and the stream associated with Garfield Gulch.

The ASARCO area is a federal Superfund site and is being cleaned up according to federal standards. ASARCO and Ruston Creeks drain small ravines in this area and are culverted under the property. Proper drainage from the hillside above the smelter is being incorporated into the clean up and design plans for the site. The City is working with the town of Ruston to insure the future land uses for the site are protective of human health and the environment, and are compatible with the long term vision of that area.

Puget and Mason Creeks are perennial and have steep slopes associated with them. Puget Creek enters the City's storm sewer system after it passes through an underground fish ladder/culvert, adjacent to Ruston Way, just upstream of its discharge point to Commencement Bay. Several community groups have worked to reintroduce salmon to Puget Creek by improving fish access and vegetative cover in Puget Creek. A fish ladder was installed in 1997 to provide fish access to the creek. None of the other creeks are fish bearing.

**Flow control: Flow control (detention) is required for all projects that meet the minimum threshold for flow control and that discharge directly or indirectly to a creek or gulch system, in accordance with Minimum Requirement #7: Therefore, for these projects, there are no specific geographic flow control requirements in this watershed.**

**Sites that meet the minimum threshold for flow control, but discharge to the City's system in this watershed are not required to do flow control, but are required to do an offsite analysis for capacity. The analysis must demonstrate that there is adequate capacity in the stormwater system within ¼ mile downstream of the project site. If capacity is available, the applicant can connect to the system without providing flow control. If the analysis indicates that there is not capacity downstream, the applicant has the option of improving the system or providing flow control.**

**Water Quality: Projects that discharge to the City's system in this watershed are not required to apply enhanced treatment. Projects that have a direct discharge to Puget Creek, or projects that have a discharge to a natural resources restoration site, shall be required to apply enhanced treatment.**

### **2.6.6 Thea Foss Waterway**

This watershed covers approximately 5,751 acres and is comprised of drainage basins located in the south-central portion of Tacoma. The area borders the North Tacoma Watershed on the north, the Flett Watershed on the west and south, and the Tideflats and T-Street/Lower Puyallup Watersheds on the east. The area extends as far south as 86th Street and also includes portions of the tideflats (including Middle and St. Paul Waterway) on the east side of Foss Waterway.

The City's primary outfalls to the Thea Foss Waterway are 237A & B (the twin 96ers), 230, 245, 254, 218, 214, 225, 235, and 248. Primary land uses within the basins draining to each of these outfalls are as follows:

#### Outfall

237A	residential, commercial and industrial
237B	residential
230	commercial
245	commercial and industrial
254	industrial
218	industrial
214	industrial
225	business, commercial and light industrial
235	residential, commercial and industrial
248	industrial

Land use is predominately residential, although most of Tacoma's commercial businesses are located in this watershed. There are some industrial uses, concentrated mainly in the tideflats and Nalley Valley portions of the watershed.

On September 8, 1983, EPA placed the Commencement Bay Nearshore/Tideflats (CB/NT) site on the National Priorities List for cleanup pursuant to the Comprehensive Environmental Response,

Compensation, and Liability Act (CERCLA), commonly known as Superfund. On September 29, 1989, EPA issued a Record of Decision (ROD), which outlined the remedy for remediation of sediments and control of sources of contamination in eight problem areas of the CB/NT site, including the head and mouth of the Thea Foss Waterway and the Wheeler-Osgood Waterway. Washington State Department of Ecology (Ecology) cited five City of Tacoma storm drains as historical and ongoing sources of contamination for PAHs and metals.

On March 23, 1994, the City of Tacoma entered into an Administrative Order on Consent (AOC) with EPA for Pre-Remedial Design and Remedial Design of the Thea Foss and Wheeler-Osgood Waterways. The AOC requires the City to, among other things, assess the nature and extent of contaminants in the waterways, evaluate appropriate remediation alternatives, perform a recontamination evaluation, and recommend a remediation plan. Under the current project schedule, the City will complete its work under the AOC in 2002. The City is expected to undertake a large portion of the remedial work.

A recontamination evaluation for the Thea Foss and Wheeler-Osgood Waterways has been performed under the AOC (Preliminary Draft Design Analysis Report for the Thea Foss and Wheeler-Osgood Waterways Remediation/ St. Paul Confined Disposal Facility Project, Hart Crowser, October, 2000). Chemicals of concern that have been identified include PAHs and phthalates.

Following a cleanup action in Thea Foss and Wheeler-Osgood Waterways, it is necessary to ensure that all sources (stormwater and other ongoing sources) are adequately controlled to prevent recontamination of the remediated areas. The City has entered an AOC Stormwater Work Plan Addendum dated January 23, 2002 with EPA. The addendum provides a detailed schedule and work plan for City of Tacoma's stormwater source control efforts that may be necessary to prevent recontamination of receiving water sediments within the Thea Foss and Wheeler-Osgood Waterways. This Work Plan Addendum includes a description of ongoing stormwater monitoring efforts, studies, source control efforts, and a decision matrix to identify the need for additional stormwater source controls to ensure protection of the waterway sediments from recontamination by stormwater sources

In 1995 Ecology incorporated a special provision (Special Condition S12) relating to source control efforts for the Thea Foss Waterway Subwatershed into the City's general NPDES stormwater permit. The City has entered an Administrative Water Quality Order (Order No. DE 01WQH-3241 dated September 17, 2001) with Ecology for the NPDES Final Stormwater Monitoring Sampling and Analysis Plan (Foss SAP) for Thea Foss Waterway (dated September 2001). Ecology intends to include a special condition for Tacoma's discharges to Thea Foss and Wheeler-Osgood Waterways when the new permit is issued.

**Flow Control:** Projects in this watershed do not normally require flow control (detention) since the City's system is completely piped to marine outfalls. However, projects that meet the minimum threshold for flow control are required to do an offsite analysis for capacity, including tidal influence. The analysis must demonstrate that there is adequate capacity in the stormwater system within ¼ mile downstream of the project site. If capacity is available, the applicant can connect to the system without providing flow control. If the analysis indicates that there is not capacity downstream, the applicant has the option of improving the system or providing flow control.

**Water Quality:** Additional requirements beyond those imposed by Minimum Requirement #6 may apply in this watershed. Future projects will be evaluated with reference to the administrative orders (i.e., AOC Work Plan and Water Quality Order). Additional water quality conditions may be placed on projects if additional protection is necessary.

### **2.6.7 Tideflats**

This watershed covers 2,112 acres and is the most highly industrialized and commercialized portion of the City. The majority of the City's heavy industrial facilities are located here. The area is bordered by the T-Street/Lower Puyallup Watershed on the west, Northeast Tacoma to the east and Commencement Bay and the City of Fife to the north and south, respectively. Included in this watershed are the Sitcum, Blair, and Hylebos Waterways. The Milwaukee Waterway was filled and capped during 1993-1995. The Sitcum and Hylebos Waterways have been identified as Superfund sites. Through recent annexations in the tideflats area, the City now owns and operates stormwater facilities formerly owned and operated by the City of Fife.

Some of Tacoma's stormwater discharges to the Hylebos and Blair Waterways are not covered under Ecology's 1995 Municipal Stormwater Permit. These discharges are exempted in accordance with Special Condition S2.D. of the General Permit which states that the permit does not authorize discharges of stormwater to portions of the Puyallup River and other waters on trust or restricted lands within the 1873 Survey Area of the Puyallup Tribe of Indians Reservation.

**Flow control:** Flow control (detention) is required for all projects that meet the minimum threshold for flow control and that discharge directly or indirectly to a creek, in accordance with Minimum Requirement #7. Therefore, for these projects, there are no specific geographic flow control requirements in this watershed.

**Sites that meet the minimum threshold for flow control, but discharge to the City's system in this watershed are not required to do flow control, but are required to do an offsite analysis for**

capacity, including tidal influence. The analysis must demonstrate that there is adequate capacity in the stormwater system within ¼ mile downstream of the project site. If capacity is available, the applicant can connect to the system without providing flow control. If the analysis indicates that there is not capacity downstream, the applicant has the option of improving the system or providing flow control. Note: In this watershed there are large diameter storm pipes that are not considered trunk lines.

**Water Quality: Projects that discharge to a natural resources restoration area shall be required to apply enhanced treatment.**

#### ***2.6.7.1 - Sitcum Waterway***

The Sitcum Waterway is one of the smaller waterways and is located between the much larger Blair Waterway and the Puyallup River.

In August 1986, the City of Tacoma signed a Memorandum of Agreement (MOA) with the Department of Ecology that required the City to perform an extensive study of five major drainage basins discharging to Commencement Bay and to “implement a pollution control strategy which will cause the abatement of pollutants known to be discharging from the City of Tacoma publicly owned storm drain system into the Commencement Bay Waterways and Puget Sound.” One of the five drainage basins studied under this MOA was the drainage basin associated with outfall #SI-172 draining into Sitcum Waterway.

In November 1991, Ecology and the City signed a Water Quality Consent Order #DE 91-S238, that required the City of Tacoma to continue source control work for the storm drain system that discharged to outfall #SI-172. The plan for this program was documented in a basic plan and an enhanced plan issued by the City of Tacoma and approved by Ecology in 1993.

In response to these actions, the City of Tacoma staff in cooperation with Ecology staff worked together educating business operators and inspecting businesses within this basin. Other activities included cleaning all of the catch basins within the Sitcum Waterway drainage area. Signs were also posted in the drainage area reminding people of the importance of not dumping anything on the ground. The City has continued with catch basin cleaning and street sweeping in this area as needed and continues to monitor the businesses in the area.

#### ***2.6.7.2 - Hylebos Waterway***

The Hylebos is a large waterway and is the most easterly waterway draining to Commencement Bay. The City has several stormwater discharges to the waterway.

In 1983 the U.S. Environmental Protection Agency (EPA) declared Commencement Bay Nearshore Tidelands a Superfund clean-up site. The Hylebos Waterway is designated as a part of the larger site targeted for environmental cleanup under Superfund law. Pre-remedial design activities are currently underway in the Hylebos Waterway under an Administrative Order on Consent (AOC) signed in 1993 between EPA and a group of private entities.

Hylebos Creek discharges into the head of the Waterway. Very little of Hylebos Creek flows through the City of Tacoma. The headwaters form in Federal Way, then it flows into Pierce County through the Cities of Milton, Fife and Edgewood and the eastern edge of the Tacoma tidelands before discharging into the Waterway. The portion of the Creek that flows through Tacoma is located in an area of manufacturing and other industrial operations. The Fife ditch system joins Hylebos Creek just upstream of the creek's discharge to the Hylebos Waterway. Revegetation and restoration projects have occurred on the Hylebos and the creek is utilized by salmonids.

#### **2.6.7.3 - Blair Waterway**

The Blair Waterway is a large waterway located between the Sitcum and Hylebos Waterways. The City has several discharges to the Waterway.

Contaminated and clean dredged fill material from the Blair Waterway was used as fill for the Milwaukee Waterway when it was filled and capped from 1993-1995.

Wapato Creek discharges into the head of the Blair Waterway. The lowest portion of this creek is located in the City of Tacoma and very little information is available about it. This creek, however, has historically been utilized by salmonids.

#### **2.6.7.4 - Middle Waterway**

The Middle Waterway is a medium sized waterway located between the Thea Foss Waterway and the Puyallup River. The City has several discharges to the Waterway.

This Waterway is surrounded by industrial activity except at the head of the Waterway where the City is involved in the restoration of a large marine habitat site through the Natural Resource Damages Assessment Program (NRDA).

#### **2.6.8 T-Street/Lower Puyallup**

This watershed covers 2,971 acres and is located in the southeast portion of Tacoma. The area borders the Foss Waterway Watershed on the west and the Tidelands Watershed and Pierce County on the east, and funnels north along the Puyallup River. The southern portion of the watershed is predominately residential with some undeveloped open space and a few

small commercial areas. Included in this watershed are Interstate 5 from Fife to the Tacoma Dome, Salishan, Portland Avenue, the T-Street Gulch area, and the area east of the Tacoma Dome, including the Tacoma Dome. The northern portion of the watershed consists of industrial and commercial areas. Waterbodies within this watershed include the Puyallup River, Swan Creek and the T-Street Gulch.

Tacoma's stormwater discharges to the Puyallup River are not covered under Ecology's General Permit for the South Puget Sound Water Management Area. These discharges are exempted in accordance with Special Condition S2.D. of the General Permit which states that the permit does not authorize discharges of stormwater to portions of the Puyallup River and other waters on trust or restricted lands within the 1873 Survey Area of the Puyallup Tribe of Indians Reservation.

### **2.6.8.1 - Puyallup River**

The Puyallup River is of area-wide significance. The associated drainage basin occupies approximately 972 square miles in the Puget Lowlands. Its two major tributaries are the White and Carbon Rivers which contribute 50% and 30% of the Puyallup River flow, respectively. The lower portion of the river from its mouth to approximately two miles upstream is located within the City of Tacoma. The lower Puyallup at Commencement Bay is a salt-wedge estuary, with deeper marine water overlain by a layer of fresh water. This estuary has been extensively modified, losing up to 99% of its estuarine wetland area. Recent habitat restoration efforts have resulted in increased wetland acreage including a project at the Simpson site and the creation of the Gog-le-hi-te wetland located near the mouth of the river on the east side. Below River Mile 2.0 in the tideflats area, industrial activity is dominant. The river along with its tributaries serve as major migration routes for a variety of salmonids. There are four fish hatcheries located in this system upstream of Tacoma.

**Flow Control: Projects that discharge directly to the Puyallup River in a completely piped system do not normally require flow control (detention), because of the large capacity of the river system, the diked banks and the extreme tidal influence. However, projects that meet the minimum threshold for flow control are required to do an offsite analysis for capacity. The analysis must demonstrate that there is adequate capacity in the stormwater system within ¼ mile downstream of the project site. If capacity is available, the applicant can connect to the system without providing flow control. If the analysis indicates that there is not capacity downstream, the applicant has the option of improving the system or providing flow control.**

**Water Quality: Projects that discharge to the Puyallup River are not required to apply enhanced treatment.**

### **2.6.8.2 - Swan Creek**

Swan Creek originates in Pierce County south of Highway 512. It flows north towards the Puyallup River and along the City of Tacoma-Pierce County boundary. It enters a narrow canyon at approximately creek mile three and leaves the canyon at Pioneer Road (approximately creek mile 0.5). The creek then flows north then east to its confluence with Clear Creek. Clear Creek then flows into the Puyallup River. This discharge point is located in unincorporated Pierce County. This creek is used by salmonids.

Its associated drainage basin is large, encompassing hundreds of acres. Most of the area is located in unincorporated Pierce County. A small portion of the basin lies along the City of Tacoma's eastern border. Much of the land located within the lower portion of the drainage basin is located within Swan Creek Park, which is owned and operated by Metro Parks Tacoma. The City of Tacoma maintains one 10-inch stormwater discharge pipe to the Creek. The City is involved in the restoration of a large habitat site near the mouth of Swan Creek through the Natural Resource Damages Assessment Program (NRDA).

Swan Creek is experiencing erosion problems due to erodible soils and increased flows in the basin. Sediments are being deposited in the lower portions of the channel, near Pioneer Way and in the past have blocked the culvert flowing under the road causing it to flood. Pierce County installed a sedimentation pond off Pioneer Way to collect these sediments. County crews maintain the ponds. Pierce County also completed the installation of 4 stormwater detention ponds in the vicinity of Waller Road and East 80th Street.

**Flow Control: All projects that discharge stormwater directly or indirectly to Swan Creek and meet the minimum threshold for flow control (detention) will be required to provide flow control, in accordance with Minimum Requirement #7: Therefore, there are no specific geographic flow control requirements in this watershed.**

**Water Quality: Projects that discharge to a natural resources restoration area shall be required to apply enhanced treatment.**

### **2.6.8.3 - T-Street Gulch**

The T-Street Gulch drainage basin encompasses approximately 2,500 acres of residential/commercial area. The majority of the basin is within the City of Tacoma, although approximately 600 acres lie within unincorporated Pierce County.

The T-Street Gulch has experienced extensive erosion problems due to erodible soils, continued development and extreme storm events. The T-street basin is not yet fully developed and increased stormwater flows are expected from both the City of Tacoma and Pierce County. The City recently constructed a capital improvement project in 1997 and 1998 to



provide bank/channel stabilization including hardening the channel with large rip-rap and concrete and actual piping of the gulch in some areas.

**Flow Control:** In this watershed, sites that meet the minimum threshold for flow control are not required to do flow control, but are required to do an offsite analysis for capacity. The analysis must demonstrate that there is adequate capacity in the stormwater system within ¼ mile downstream of the project site. If capacity is available, the applicant can connect to the system without providing flow control. If the analysis indicates that there is not capacity downstream, the applicant has the option of improving the system or providing flow control.

### **2.6.9 Western Slopes Watershed**

This watershed covers 2,090 acres and is located in the northwest portion of Tacoma. This area drains to The Narrows Passage. The watershed borders the North Tacoma Watershed and Leach Creek Watershed on the east and The Narrows Passage on the west. With the exception of the west end of 6th Avenue and a portion of Point Defiance Park, the area is predominately residential with many steep slopes. Underground springs and near surface groundwater are characteristic of the steep slopes in this area. Two small creeks discharge directly into the Narrows. These are Gold Creek and Narrows Creek. Narrows Creek is perennial. Gold Creek has intermittent flow. Crystal Creek is also located in this area. These are not fish bearing creeks. Residential development continues in this area.

**Flow Control:** For projects that meet the minimum threshold for flow control (detention) and that discharge directly or indirectly to a creek or gulch system, flow control is required, in accordance with Minimum Requirement #7: Therefore, for these projects, there are no specific geographic flow control requirements in this watershed.

**Sites that meet the minimum threshold for flow control, but do not discharge to a creek or gulch system, but are instead piped all the way to a marine outfall, are required to do an offsite analysis for capacity. The analysis must demonstrate that there is adequate capacity in the stormwater system within ¼ mile downstream of the project site. If capacity is available, the applicant can connect to the system without providing flow control. If the analysis indicates that there is not capacity downstream, the applicant has the option of improving the system or providing flow control.**

## **2.7 Flow Control Requirements for Specific Watersheds**

### **2.7.1 Overview**

The requirements for stormwater flow control (detention) are determined by the location of the stormwater discharge and by the system's capacity. If the stormwater goes directly or indirectly into a stream or a gulch

system, then stormwater flow control in accordance with Minimum Requirement # 7 is required to protect the natural environment. If the stormwater is piped all of the way to a marine outfall, then flow control is not usually required. Table 2.7.1 shows the general detention requirements in the various watersheds within the City. Please refer to the notes below the table for specific information about flow control. Refer to Figure 2-1 for a map of the City watersheds.

### **2.7.2 In-Lieu-Of Flow Control Policy**

Flow control (detention) is required for those sites that meet the threshold for flow control in Section 3.4.1. In the Flett Creek and Leach Creek Watersheds, the City is planning to upgrade existing regional flow control basins. At the option of the applicant, a contribution to a City fund may instead be made to upgrade the existing stormwater system. The contribution is permitted via RCW82.01.020.

If the applicant chooses to make the contribution, an engineering analysis of the downstream drainage system must be done per Section 3.6.1 of this Volume. The analysis must demonstrate that there is adequate capacity in the stormwater system within  $\frac{1}{4}$  mile downstream of the project site. If capacity is available, the applicant can pay the contribution and connect to the system without providing flow control. If the analysis indicates that there is *not* capacity downstream, the applicant has the option of improving the system and then paying the in-lieu-of contribution, or providing flow control. If the applicant does not improve the system and flow control is required, no contribution can be made.

Note: If requesting the in-lieu of fee, the off-site analysis should be submitted prior to submitting building permits. Although, the City strives to review submittals in a timely manner, the applicant's project may be delayed if problems are found with the project's downstream analysis.

**Table 2.7.1 Watershed Flow Control Requirements if Applicable Thresholds are Met per Minimum Requirement #7.**

<b>Watersheds*</b>	<b>Detention if discharge to stream or gulch <sup>1</sup></b>	<b>Detention or in-lieu-of <sup>2</sup></b>	<b>¼ mile analysis <sup>3</sup></b>
Western Slopes	x		x
Leach Creek		x	x
Flett Creek		x	x
Lower Puyallup	x		x
NE Tacoma	x		x
Joe's Creek	x		x
Foss			x
North Tacoma	x		x
Tideflats	x		x

\* Please call the Environmental Services Science and Engineering Division at 253-591-5588 for current detention requirements.

- Notes:
1. Flow control is required if discharge is directly or indirectly to a stream or gulch.
  2. Flow control is required. At the option of the applicant, a contribution to a City fund may instead be made to upgrade the existing stormwater system. If the applicant chooses to make the contribution, an engineering analysis of the downstream drainage system must be done. The analysis must demonstrate that there is adequate capacity in the stormwater system within ¼ mile downstream of the project site. If the analysis indicates that there is not capacity downstream, the applicant has the option of improving the system or providing flow control. If the applicant does not improve the system and flow control is required, no contribution can be made. Please refer to Section 3.6.1 of the Surface Water Design Manual for more information on completing an off-site analysis.
  3. If flow control is not required as a result of one of the above notes, but the project meets the thresholds for flow control identified in Minimum Requirement #7, applicants are required to perform an off-site analysis of the downstream drainage system for capacity. If the analysis shows the system has deficient capacity within ¼ mile of the site, the applicant has the option of correcting this deficiency or providing flow control. Please refer to Section 3.6.1 of this volume for more information on completing an off-site analysis.

Table 2.7.2 In-Lieu-Of Flow Control

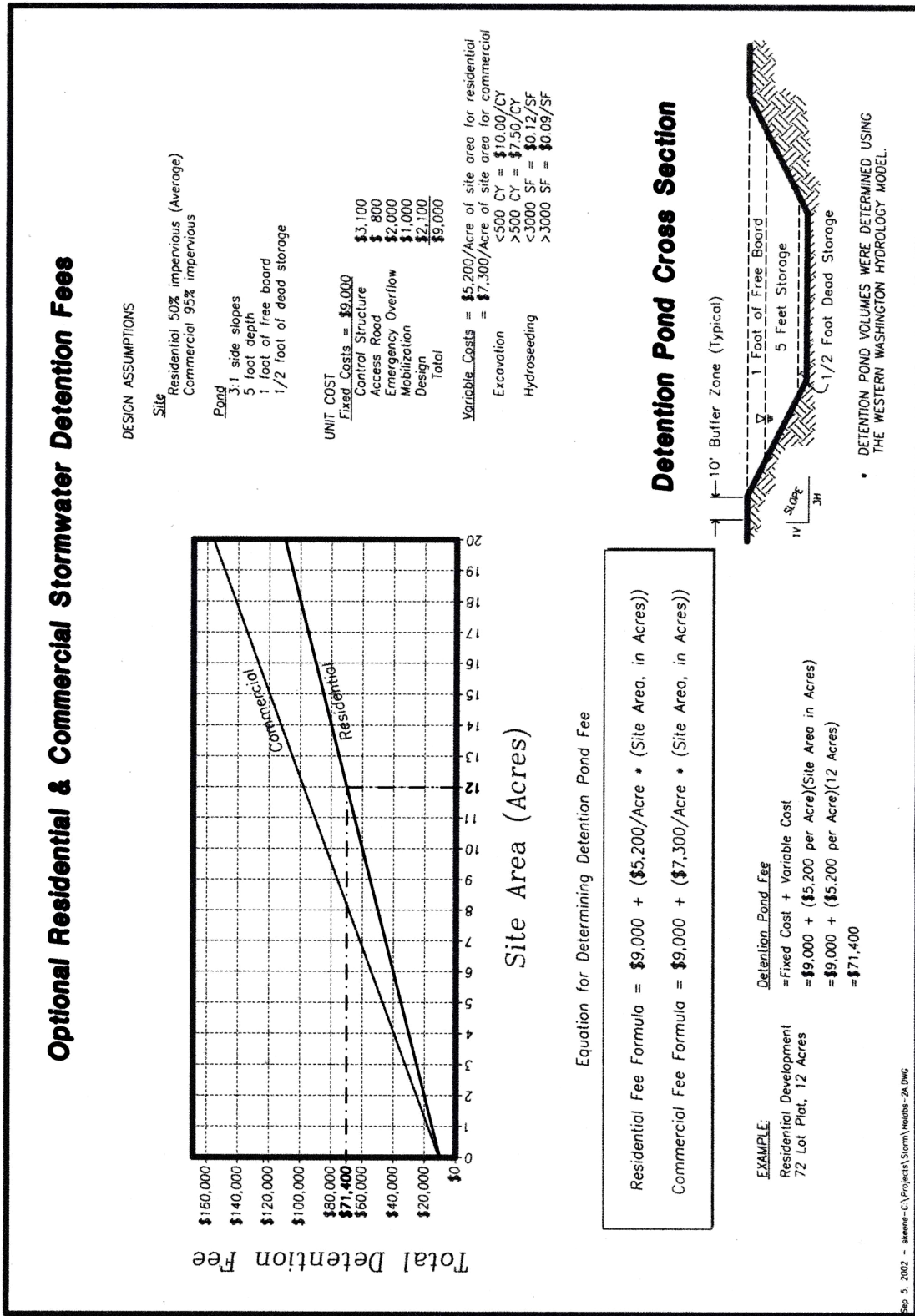


Table 2.7.3 In-Lieu-Of Flow Control

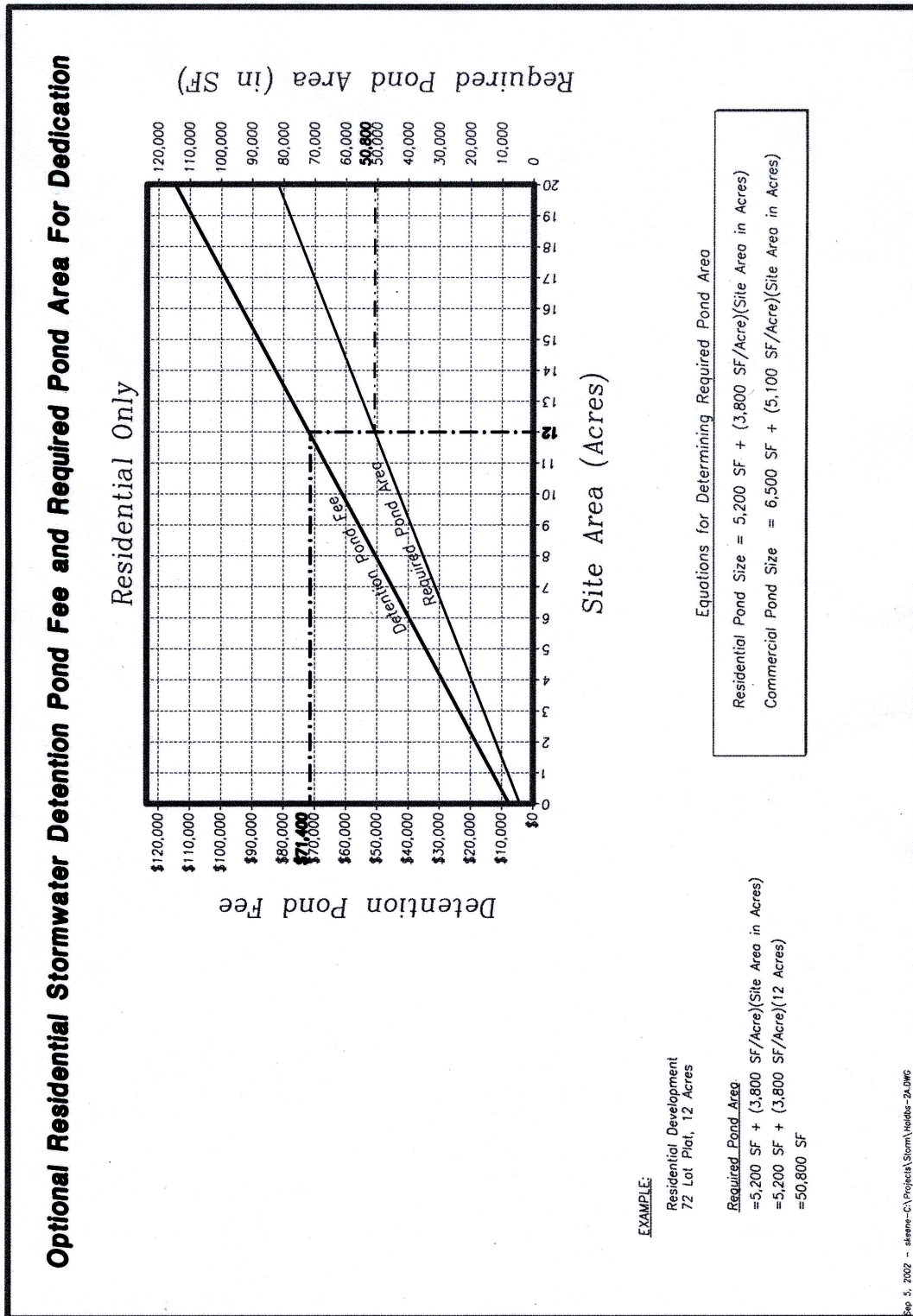
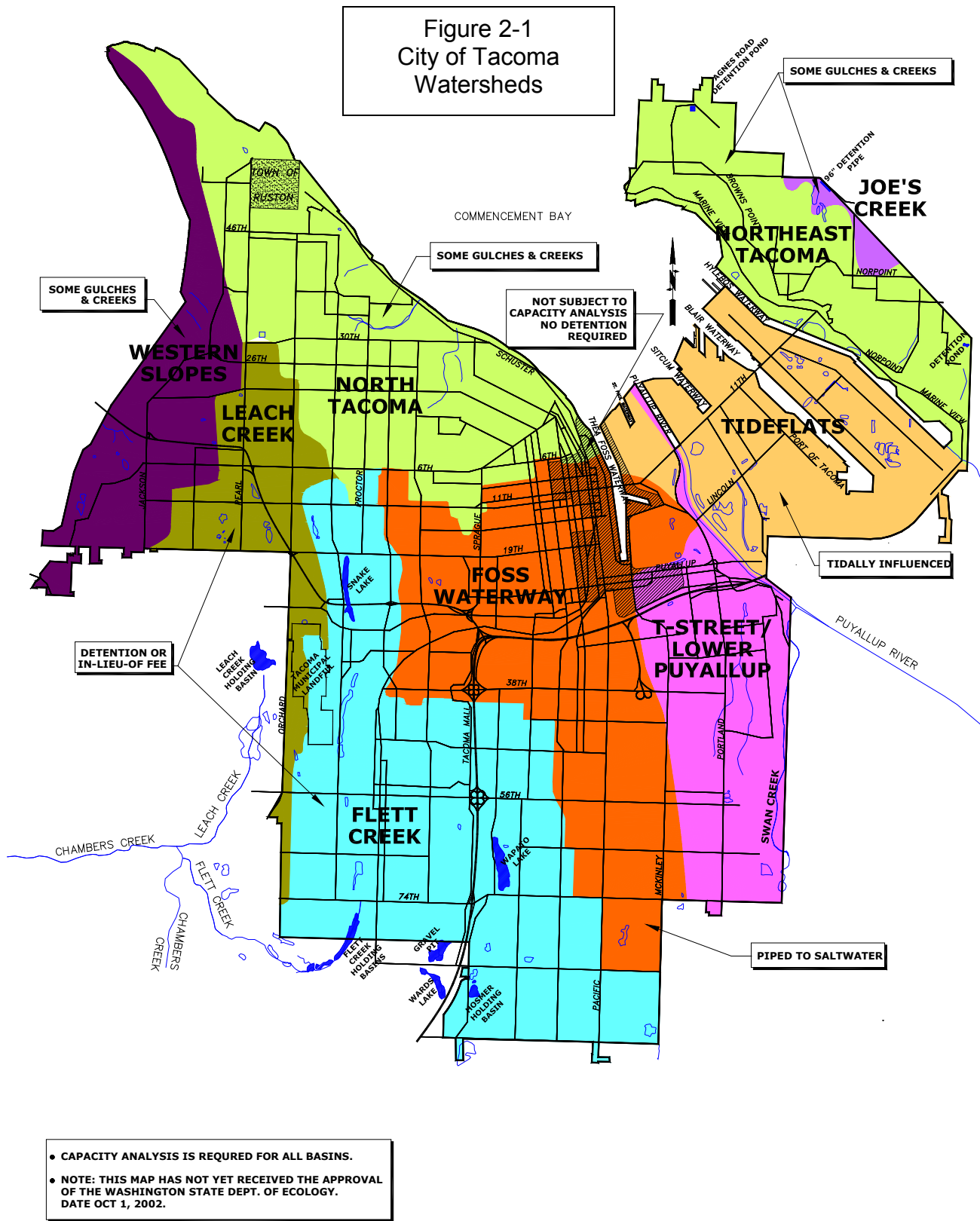
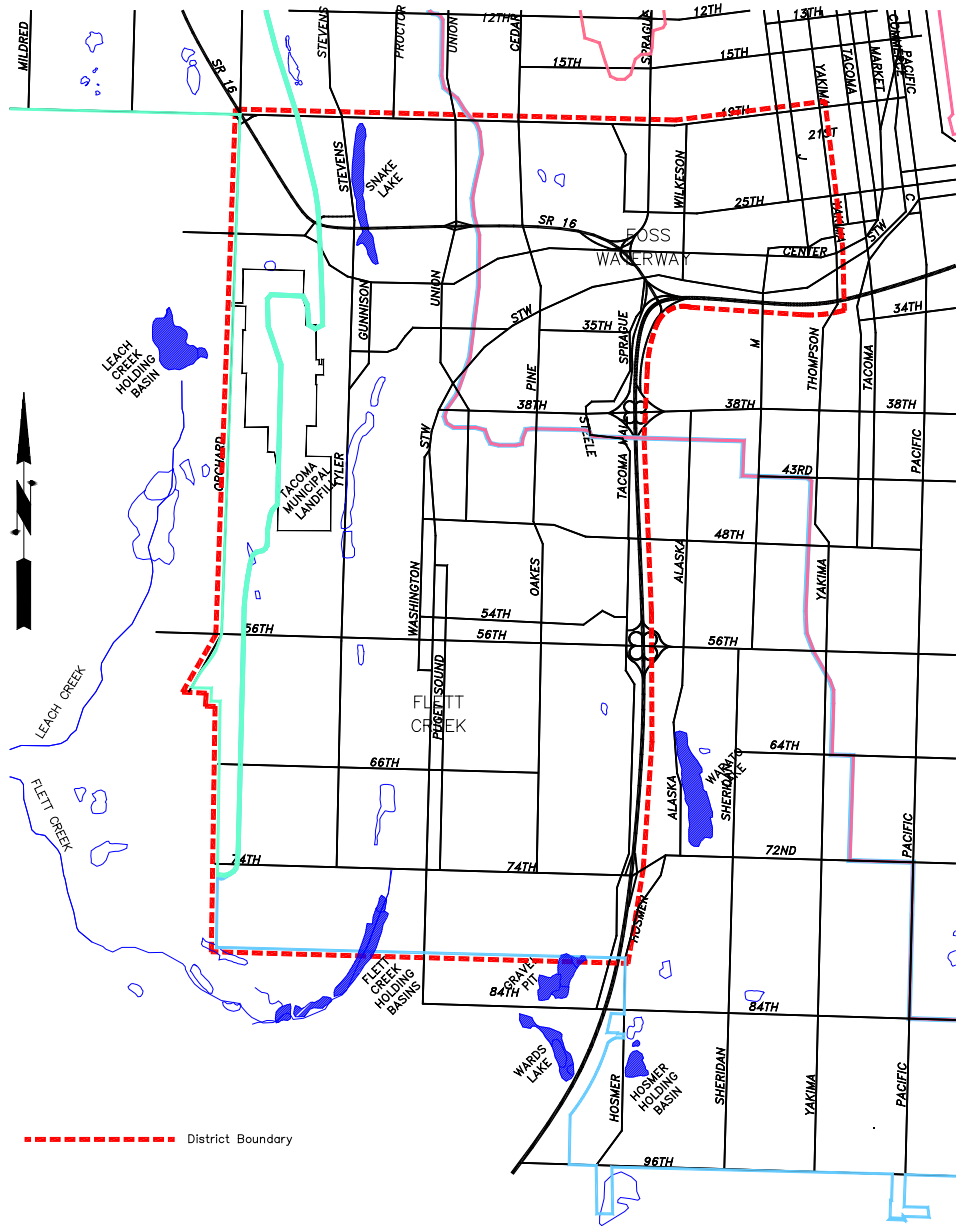


Figure 2-1  
City of Tacoma  
Watersheds



• CAPACITY ANALYSIS IS REQUIRED FOR ALL BASINS.  
 • NOTE: THIS MAP HAS NOT YET RECEIVED THE APPROVAL OF THE WASHINGTON STATE DEPT. OF ECOLOGY. DATE OCT 1, 2002.

Figure 2-2  
 South Tacoma  
 Groundwater Protection District Map



## **Chapter 3 - Minimum Requirements for New Development and Redevelopment**

---

This Chapter identifies the ten Minimum Requirements for stormwater management applicable to new development and redevelopment sites. These requirements are codified in Chapter 12.08 of the Tacoma Municipal Code (TMC). New development and redevelopment projects also may be subject to other City code requirements, depending upon the nature and location of the project. These code requirements may include, but are not limited to, the subdivision and land use permit procedures in Chapters 13.04 and 13.05 TMC; excavation and grading and off-site improvement Chapter 2.02 TMC; driveway control Chapter 10.14; groundwater protection, Chapter 12.09 TMC; shoreline regulation, Chapter 13.10 TMC; and critical areas preservation Chapter 13.11 TMC.

These requirements are intended to provide for and promote the health, safety and welfare of the general public, and are not intended to create or otherwise establish or designate any particular class or group of persons who will or should be especially protected or benefited by the provisions of this chapter.

The Minimum Requirements are:

1. Preparation of Stormwater Site Plans
2. Construction Stormwater Pollution Prevention
3. Source Control of Pollution
4. Preservation of Natural Drainage Systems and Outfalls
5. On-site Stormwater Management
6. Runoff Treatment
7. Flow Control
8. Wetlands Protection
9. Basin/Watershed Planning
10. Operation and Maintenance

The City also has two additional requirements beyond those required in Ecology's 2001 manual:

1. Off-Site Analysis and Mitigation
2. Financial Liability

Depending on the type and size of the proposed project, different combinations of these minimum requirements apply. In general, small sites are required to control erosion and sedimentation from construction activities and to apply simpler approaches to treatment and flow control of stormwater runoff from the developed site.

Large sites must provide erosion and sedimentation control during construction, permanent control of stormwater runoff from the developed site through selection of appropriate BMPs and facilities, and other measures to reduce and control the onsite and offsite impacts of the project. Sites being redeveloped must generally meet the same minimum



requirements as new development for the new impervious surfaces and pervious surfaces converted from natural vegetation to lawn or landscaped areas. Redevelopment sites must also provide erosion control, source control, and on-site stormwater management for the portion of the site being redeveloped (i.e. replaced impervious surfaces). In addition, if the redevelopment meets certain cost or space (as applied to roads) thresholds, updated stormwater management for the redeveloped pervious and impervious surfaces must be provided. There may also be situations in which additional controls are required for sites, regardless of type or size, as a result of basin plans or special water quality concerns.

Development sites are to demonstrate compliance with these requirements through the preparation of Stormwater Site Plans (SSP). The plans are described in detail in Chapter 4. Two major components of these plans are a Construction Stormwater Pollution Prevention Plan (SWPPP) and a Permanent Stormwater Control Plan (PSCP). The Construction SWPPP shall identify how the project intends to control pollution generated during the construction phase only, primarily erosion and sediment. The PSCP shall identify how the project intends to provide BMPs for the control of pollution from stormwater runoff after construction has been completed. Sites must submit these plans for review if they add or replace 2,000 square feet or more of impervious surface, or disturb 7,000 square feet or more of land.

Section 3.4 provides additional information on applicability of the Minimum Requirements to different types of sites.

### **3.1 Relationship to Ecology's 2001 Stormwater Management Manual and the Puget Sound Water Quality Management Plan**

Ecology's 2001 Stormwater Management Manual was originally developed to comply with the 1991 Puget Sound Water Quality Management Plan. That plan (as amended) is a voluntary plan that requires all counties and cities within the Puget Sound drainage basin to adopt stormwater programs which include minimum requirements for new development and redevelopment set by the Plan and in guidance developed by the Department of Ecology (Ecology). The programs are to include ordinances that address:

*"... at a minimum: (1) the control of off-site water quality and quantity effects; (2) the use of best management practices for source control and treatment; (3) the effective treatment, using best management practices, of the storm size and frequency (design storm) as specified in the manual for proposed development; (4) the use of infiltration, with appropriate precautions, as the first consideration in stormwater management; (5) the protection of stream channels, fish, shellfish habitat, other aquatic habitat, and wetlands; (6) erosion and sedimentation*

*control for new construction and redevelopment projects; and (7) local enforcement of these stormwater controls."*

Ecology considers the above description to be generic to proper stormwater management in any region within the state of Washington.

This manual is modeled after Ecology's 2001 Stormwater Management Manual. Ecology considers its manual to include all known, available and reasonable methods of prevention and treatment (AKART). Ecology's manual has no independent regulatory authority. However, Ecology has required as a condition of the City's General Permit for Discharges from Municipal Separate Storm Sewers, the adoption of stormwater program components that are the substantial equivalent to the minimum requirements found in Ecology's 2001 manual.

The minimum requirements of this Chapter are conditions of the City's stormwater NPDES permit, and are required under Tacoma's Municipal Code, Chapter 12.08, *Sewage Disposal and Drainage Regulations and Rates*. **Throughout this Chapter, requirements to meet the City's ordinance are written in BOLD and supplemental guidelines that serve as advice and other materials are not in bold.**

To have an equivalent manual, local governments throughout Western Washington have been required to adopt into ordinance and/or enforceable rules, the definitions, thresholds, minimum requirements, and adjustment and variance criteria that are displayed in bold. Alternative definitions, thresholds, minimum requirements, and adjustment and variance criteria are acceptable if they provide equivalent protection of receiving waters and equivalent levels of treatment and control.

## **3.2 Exemptions**

### **3.2.1 Forest Practices**

Forest practices regulated under Title 222 WAC, except for Class IV General forest practices that are conversions from timberland to other uses, are exempt from the provisions of the minimum requirements.

### **3.2.2 Road Maintenance**

The following road maintenance practices are exempt: pothole and square cut patching, overlaying existing asphalt or concrete pavement with asphalt or concrete without expanding the area of coverage, shoulder grading, reshaping/regrading drainage systems, crack sealing, resurfacing with in-kind material without expanding the road prism, and vegetation maintenance.

The following road maintenance practices are considered redevelopment, and therefore are **not** categorically exempt. The extent to which the manual applies is explained for each circumstance.

- Removing and replacing a paved surface to base course or lower, or repairing the roadway base: If impervious surfaces are not expanded, Minimum Requirements #1 - #5 apply. However, in most cases, only Minimum Requirement #2, Construction Stormwater Pollution Prevention, will be germane. Where appropriate, project proponents are encouraged to look for opportunities to use permeable and porous pavements.
- Extending the pavement edge without increasing the size of the road prism, or paving graveled shoulders: These are considered new impervious surfaces and are subject to the minimum requirements that are triggered when the thresholds identified for redevelopment projects are met.
- Resurfacing by upgrading from dirt to gravel, asphalt, or concrete; upgrading from gravel to asphalt, or concrete; or upgrading from a bituminous surface treatment ("chip seal") to asphalt or concrete: These are considered new impervious surfaces and are subject to the minimum requirements that are triggered when the thresholds identified for redevelopment projects are met.

### **3.2.3 Underground Utility Projects**

Underground utility projects that replace the ground surface with in-kind material or materials with similar runoff characteristics are only subject to Minimum Requirement #2, Construction Stormwater Pollution Prevention.

All other new development is subject to one or more of the Minimum Requirements (see Section 2.4).

### **3.2.4 Minor Clearing and Grading**

**The following minor clearing and grading activities are exempt from all the Minimum Requirements except for Minimum Requirement #2; unless located within a critical or sensitive area governed by the City's Critical Areas Preservation Ordinance. The amount of area disturbed will determine the need for a Construction Stormwater Pollution Prevention Plan per section 3.5.2. All land disturbances shall be stabilized meeting Minimum Requirement #2, Element # 5 – Stabilize Soils and as outlined in Volume II.**

- Cemetery graves;
- Excavation for wells, except that fill made with the material from such excavation shall not be exempt;
- Exploratory excavations under the direction of soil engineers or engineering geologists, except that fill made with the material from such excavation shall not be exempt;
- Removal of hazardous trees;

- Removal of trees or other vegetation which cause sight distance obstructions at intersections so determined by the City of Tacoma traffic engineer;
- Land clearing associated with routine maintenance by public utility agencies, so long as appropriate vegetation management practices are followed as described in the Best Management Practices of the Regional Road Maintenance Endangered Species Act Program Guidelines.

### 3.2.5 Emergencies

Emergency projects which, if not performed immediately would substantially endanger life or property, are exempt only to the extent necessary to meet the emergency. Emergency activities may include but are not limited to: sandbagging, diking, ditching, filling or similar work during or after periods of extreme weather. Permits authorizing the emergency work may be required after completion of the emergency project.

## 3.3 Definitions Related to Minimum Requirements

A full listing and definition of stormwater-related words and phrases that are used in this manual is given in the glossary. A few of the key definitions are listed here for ease in understanding the requirements that follow.

- **Arterial** - A road or street primarily for through traffic. A major arterial connects an Interstate Highway to cities and counties. A minor arterial connects major arterials to collectors. A collector connects an arterial to a neighborhood. A collector is not an arterial. A local access road connects individual homes to a collector.
- **Effective Impervious Surface** - Those impervious surfaces that are connected via sheet flow or discrete conveyance to a drainage system. Impervious surfaces on residential development sites are considered ineffective if the runoff is dispersed through at least one hundred feet of native vegetation in accordance with BMP T5.30 – “Full Dispersion,” as described in Chapter 5 of Volume V.
- **Highway** - A main public road connecting towns and cities.
- **Impervious Surface** - A hard surface area that either prevents or retards the entry of water into the soil mantle as under natural conditions prior to development. A hard surface area which causes water to run off the surface in greater quantities or at an increased rate of flow from the flow present under natural conditions prior to development. Common impervious surfaces include, but are not limited to, roof tops, walkways, patios, driveways, parking lots or storage areas, concrete or asphalt paving, gravel roads, packed earthen materials, and oiled, macadam or other surfaces which similarly impede the natural infiltration of stormwater. Open, uncovered retention/detention facilities shall not be considered as impervious surfaces for purposes of determining whether the

thresholds for application of minimum requirements are exceeded. Open, uncovered retention/detention facilities shall be considered impervious surfaces for purposes of runoff modeling.

- **Land Disturbing Activity** - Any activity that results in movement of earth, or a change in the existing soil cover (both vegetative and non-vegetative) and/or the existing soil topography. Land disturbing activities include, but are not limited to clearing, grading, filling, and excavation. Compaction that is associated with stabilization of structures and road construction shall also be considered a land disturbing activity. Vegetation maintenance practices are not considered land-disturbing activity.
- **Maintenance** - Repair and maintenance includes activities conducted on currently serviceable structures, facilities, and equipment that involves no expansion or use beyond that previously existing and results in no significant adverse hydrologic impact. It includes those usual activities taken to prevent a decline, lapse, or cessation in the use of structures and systems. Those usual activities may include replacement of dysfunctional facilities, including but not limited to cases where environmental permits require replacing an existing structure with a different type structure, as long as the functioning characteristics of the original structure are not changed. One example is the replacement of a collapsed, fish blocking, round culvert with a new box culvert under the same span, or width, of roadway. For further details on the application of this manual to various road management functions, please see Section 3.2.
- **Native Vegetation** - Vegetation comprised of plant species, other than noxious weeds, that are indigenous to the coastal region of the Pacific Northwest and which reasonably could have been expected to naturally occur on the site. Examples include trees such as Douglas Fir, western hemlock, western red cedar, alder, big-leaf maple, and vine maple; shrubs such as willow, elderberry, salmonberry, and salal; and herbaceous plants such as sword fern, foam flower, and fireweed.
- **New Development** - Land disturbing activities, including Class IV - general forest practices that are conversions from timber land to other uses; structural development, including construction or installation of a building or other structure; creation of impervious surfaces; and subdivision, short subdivision and binding site plans, as defined and applied in Chapter 58.17 RCW. Projects meeting the definition of redevelopment shall not be considered new development.
- **Pollution-Generating Impervious Surface (PGIS)** - Those impervious surfaces considered to be a significant source of pollutants in stormwater runoff. Such surfaces include those that are subject to: vehicular use; industrial activities (as further defined in the glossary); or storage of erodible or leachable materials, wastes, or chemicals, and which receive direct rainfall or the run-on or blow-in of rainfall. Erodeable or leachable materials, wastes, or chemicals are those substances which, when exposed to rainfall, measurably alter the physical or chemical characteristics of the rainfall runoff. Examples

include erodible soils that are stockpiled, uncovered process wastes, manure, fertilizers, oily substances, ashes, kiln dust, and garbage dumpster leakage. Metal roofs are also considered to be PGIS unless they are coated with an inert, non-leachable material (e.g., baked-on enamel coating).

A surface, whether paved or not, shall be considered subject to vehicular use if it is regularly used by motor vehicles. The following are considered regularly-used surfaces: roads, unvegetated road shoulders, bike lanes within the traveled lane of a roadway, driveways, parking lots, unfenced fire lanes, vehicular equipment storage yards, and airport runways.

The following are not considered regularly-used surfaces: sidewalks, paved bicycle pathways separated from and not subject to drainage from roads for motor vehicles, fenced fire lanes, and infrequently used maintenance access roads.

- **Pollution-Generating Pervious Surfaces (PGPS)** - Any non-impervious surface subject to use of pesticides and fertilizers or loss of soil. Typical PGPS include lawns, landscaped areas, golf courses, parks, cemeteries, and sports fields.
- **Pre-Developed Condition** - The native vegetation and soils that existed at a site prior to the influence of Euro-American settlement. The pre-developed condition shall be assumed to be a forested land cover unless reasonable, historic information is provided that indicates the site was prairie prior to settlement.
- **Project Site** - That portion of a property, properties, or right of way subject to land disturbing activities, new impervious surfaces, or replaced impervious surfaces.
- **Receiving Waters** – Solely, for the purposes of applying the minimum requirements of this manual, receiving waters are bodies of water or surface water systems to which surface runoff is discharged via a point source of stormwater or via sheet flow.
- **Redevelopment** - On a site that is already substantially developed (i.e., has 35% or more of existing impervious surface coverage), the creation or addition of impervious surfaces; the expansion of a building footprint or addition or replacement of a structure; structural development including construction, installation or expansion of a building or other structure; replacement of impervious surface that is not part of a routine maintenance activity; and land disturbing activities.
- **Replaced Impervious Surface** - For structures, the removal and replacement of any exterior impervious surfaces or foundation. For other impervious surfaces, the removal down to bare soil or base course and replacement.
- **Site** - The area defined by the legal boundaries of a parcel or parcels of land that is (are) subject to new development or redevelopment.

For road projects, the length of the project site and the right-of-way boundaries define the site.

- **Source Control BMP** - A structure or operation that is intended to prevent pollutants from coming into contact with stormwater through physical separation of areas or careful management of activities that are sources of pollutants. This manual separates source control BMPs into two types. *Structural Source Control BMPs* are physical, structural, or mechanical devices, or facilities that are intended to prevent pollutants from entering stormwater. *Operational BMPs* are non-structural practices that prevent or reduce pollutants from entering stormwater. See Volume IV for details.
- **Threshold Discharge Area** - An onsite area draining to a single natural or historic discharge location or multiple natural or historic discharge locations that combine within one-quarter mile downstream (as determined by the shortest flow path). The examples in Figure 3-1 below illustrate this definition. The purpose of this definition is to clarify how the thresholds of this manual are applied to project sites with multiple discharge points.

### 3.4 Applicability of the Minimum Requirements

Not all of the Minimum Requirements apply to every development or redevelopment project. The applicability varies depending on the type and size of the project. This section identifies thresholds that determine the applicability of the Minimum Requirements to different projects. The flow charts in Figures 3-2 and 3-3 can be used to determine which requirements apply. The Minimum Requirements themselves are presented in Section 3.5. All projects should start with Figure 3-2.

#### 3.4.1 New Development

**All new development shall be required to comply with Minimum Requirement #2. In addition, new development that exceeds certain thresholds shall be required to comply with additional Minimum Requirements as follows.**

**The following new development shall comply with Minimum Requirements #1 through #5:**

- **Creates or adds 2,000 square feet, or greater, of new, replaced, or new plus replaced impervious surface area, or**
- **Has land disturbing activity of 7,000 square feet or greater,**

**In addition to complying with Minimum Requirements #1 through #5, the following new developments shall comply with Minimum Requirements #6 through 10:**

- **Creates or adds 5,000 square feet, or more, of new impervious surface area, or**

- **Converts  $\frac{3}{4}$  acres, or more, of native vegetation to lawn or landscaped areas, or**
- **Converts 2.5 acres, or more, of native vegetation to pasture**

***Supplemental Guidelines***

The City's basin planning is used to tailor certain of the Minimum Requirements to a specific basin. Treatment and flow control requirements may be modified if the project is constructed within a drainage basin containing geographic specific requirements as further described in Volume I, Chapter 2, Section 2.6 of this manual.

**3.4.2 Redevelopment**

**All redevelopment shall be required to comply with Minimum Requirement #2. In addition, all redevelopment that exceeds certain thresholds shall be required to comply with additional Minimum Requirements as follows.**

**The following redevelopment shall comply with Minimum Requirements #1 through #5 for the new and replaced impervious surfaces and the land disturbed:**

- **The new, replaced, or total of new plus replaced impervious surfaces is 2,000 square feet or more, or**
- **7,000 square feet or more of land disturbing activities.**

**In addition to meeting Minimum Requirements #1 through #5, the following redevelopment shall comply with Minimum Requirements #6 through 10 for the new impervious surfaces and converted pervious areas:**

- **Adds 5,000 square feet or more of *new* impervious surfaces or,**
- **Converts  $\frac{3}{4}$  acres, or more, of native vegetation to lawn or landscaped areas, or**
- **Converts 2.5 acres, or more, of native vegetation to pasture.**

**If the runoff from the new impervious surfaces and converted pervious surfaces is not separated from runoff from other surfaces on the project site, the stormwater treatment facilities must be sized for the entire flow that is directed to them. The City may allow the Minimum Requirements to be applied to an equivalent (flow and pollution characteristics) area within the same site. For public road projects, the equivalent area does not have to be within the project limits, but must drain to the same receiving water.**



### **Additional Requirements for the Project Site**

For road-related projects, runoff from the replaced and new impervious surfaces (including pavement, shoulders, curbs, and sidewalks) shall meet all the Minimum Requirements if the new impervious surfaces total 5,000 square feet or more and total 50% or more of the existing impervious surfaces within the project limits. The project limits shall be defined by the length of the project and the width of the right-of-way.

Other types of redevelopment projects shall comply with all the Minimum Requirements for the new and replaced impervious surfaces if the total of new plus replaced impervious surfaces is 5,000 square feet or more, and the valuation of proposed improvements – including interior improvements – exceeds 50% of the assessed value of the existing site improvements as determined from the latest available Building Evaluation Table as published by the International Conference of Building Officials in its Building Standards Magazine.

For all new and redevelopment projects on parcels under the same ownership for which permits were issued by the City during the previous 5 years, the total increase or replacement of impervious surfaces for those 5 years shall apply towards the thresholds of this section.

Under this provision, the City will review all applications filed for a specific property for the preceding five-year period. The combined total of new or replaced surfaces will be applied to the thresholds that determine applicability of the Minimum Requirements. The five-year period will not extend prior to the adoption date of the 2002 Manual.

*Note: The intent of this five-year rule is to prohibit projects that seek to circumvent the Minimum Requirements by submitting for separate permits. The separate submittals could have project areas that do not meet the thresholds, but would meet the thresholds if the projects were combined as one project.*

#### **Objective**

Redevelopment projects have the same requirements as new development projects in order to minimize the impacts from new surfaces. To not discourage redevelopment projects, replaced surfaces aren't required to be brought up to new stormwater standards unless the noted cost and space thresholds are exceeded. As long as the replaced surfaces have similar pollution-generating potential, the amount of pollutants discharged shouldn't be significantly different. However, if the redevelopment project scope is sufficiently large that the cost and space criteria noted above are exceeded, it is reasonable to require the replaced surfaces to be brought up to current stormwater standards. This is

consistent with other utility standards. When a structure or a property undergoes significant remodeling, local governments often require the site to be brought up to new building code requirements (e.g., onsite sewage disposal systems, fire systems).

### ***Supplemental Guidelines***

If runoff from new impervious surfaces, converted pervious surfaces, and replaced impervious surfaces (if the applicable cost and space threshold has been exceeded) is not separated from runoff from other existing surfaces within the project site or the site, the guidance in Volume III for offsite inflow shall be used to size the detention facilities.

The City may institute a stop-loss provision on the application of stormwater requirements to replaced impervious surfaces. A stop-loss provision is an upper limit on the extent to which a requirement is applied. For instance, there could be a maximum percentage of the estimated total project costs that are dedicated to meeting stormwater requirements. A project would not have to incur additional stormwater costs above that maximum though the standard redevelopment requirements will not be fully achieved. The allowance for a stop-loss provision pertains to the extent that treatment, flow control and wetlands protection requirements are imposed on replaced impervious surfaces. It does not apply to meeting stormwater requirements for new impervious surfaces.

Underground utility projects that replace the ground surface with in-kind material or materials with similar runoff characteristics should not be subject to redevelopment requirements except construction site erosion control.

The City will review all road projects for changes in elevations or drainage flowpath that could cause flooding, upland or stream erosion, or changes to discharges to wetlands. For example, adding curbs will result in redirecting flows and possibly causing new downstream impacts. The City may set project-specific requirements to avoid or mitigate those impacts.

## **3.5 Minimum Requirements**

This section describes the minimum requirements for stormwater management at development and redevelopment sites. Section 3.4 should be consulted to determine which requirements apply to any given project. Volumes II through V of this manual present Best Management Practices (BMPs) for use in meeting the Minimum Requirements.

**Throughout this Chapter, guidance to meet the requirements of the Puget Sound Water Quality Management Plan is written in BOLD. Supplemental guidelines that serve as advice and other materials are not written in bold.**

### **3.5.1 Minimum Requirement #1: Preparation of Stormwater Site Plans**

**All projects meeting the thresholds in Section 3.4 shall prepare a Stormwater Site Plan for local government review. Stormwater Site Plans shall be prepared in accordance with Chapter 4 of this volume.**

#### ***Objective***

The 2,000 square foot threshold for impervious surfaces and 7,000 square foot threshold for land disturbance are chosen to capture most single-family home construction and their equivalent. Note that the scope of the stormwater site plan only covers compliance with Minimum Requirements #2 through #5 if the thresholds of 5,000 square feet of impervious surface or conversion of  $\frac{3}{4}$  acre of native vegetation to lawn or landscape, or conversion of 2.5 acres of native vegetation to pasture are not exceeded.

#### ***Supplemental guidelines***

Projects proposed by departments and agencies within the local government with jurisdiction must comply with this requirement. The local government shall determine the process for ensuring proper project review, inspection, and compliance by its own departments and agencies.

### **3.5.2 Minimum Requirement #2: Construction Stormwater Pollution Prevention (SWPP)**

**All new development and redevelopment shall comply with Construction SWPP Elements #1 through #12 below. Projects in which the new, replaced, or new plus replaced impervious surfaces total 2,000 square feet or more, or disturb 7,000 square feet or more of land must prepare a Construction SWPP Plan (SWPPP) as part of the Stormwater Site Plan (see 3.5.1). Each of the twelve elements must be considered and included in the Construction SWPPP unless site conditions render the element unnecessary and the exemption from that element is clearly justified in the narrative of the SWPPP.**

The City has developed a small site BMP selection short-form for single-family residences and other small projects that create between 2,000 and 5,000 square feet of new impervious surface or disturb between 7,000 square feet and 1 acre of land. For these projects, the BMP selection short-form is intended to take the place of the Construction SWPPP. A Certified Professional in Erosion and Sediment Control is not required for those projects using the City's Construction SWPPP short-form.

**For all other projects requiring a Construction SWPP, a Certified Professional in Erosion and Sediment Control shall be identified in the Construction SWPPP and shall be on-site or on-call at all times.**

**Certification may be through the Washington State Department of Transportation/Associated General Contractors (WSDOT/AGC) Construction Site Erosion and Sediment Control Certification Program or any equivalent local or national certification and/or training program.**

Unless located in a Critical Area, projects that add or replace less than 2,000 square feet of impervious surface or disturb less than 7,000 square feet of land are not required to prepare a Construction SWPPP, but must consider all of the twelve Elements of Construction Stormwater Pollution Prevention and develop controls for all elements that pertain to the project site. If a project does not require a Construction SWPPP, handouts are available at the City's Permit Counter and on the City's website to provide information on the practices the applicant is responsible for during construction.

***Element 1: Mark Clearing Limits***

- **Prior to beginning land disturbing activities, including clearing and grading, all clearing limits, sensitive areas and their buffers, and trees that are to be preserved within the construction area should be clearly marked, both in the field and on the plans, to prevent damage and offsite impacts.**
- **Plastic, metal, or stake wire fence may be used to mark the clearing limits.**

***Element 2: Establish Construction Access***

- **Construction vehicle access and exit shall be limited to one route if possible.**
- **Access points shall be stabilized with quarry spall or crushed rock to minimize the tracking of sediment onto public roads.**
- **Wheel wash or tire baths should be located on-site, if applicable.**
- **Public roads shall be cleaned thoroughly at the end of each day. Sediment shall be removed from roads by shoveling or pickup sweeping and shall be transported to a controlled sediment disposal area. Street washing will be allowed only after sediment is removed in this manner.**
- **Street wash wastewater shall be controlled by pumping back on-site, or otherwise be prevented from discharging into systems tributary to state surface waters.**

***Element 3: Control Flow Rates***

- **Properties and waterways downstream from development sites shall be protected from erosion due to increases in the volume, velocity, and peak flow rate of stormwater runoff from the project site, as required by the City.**

- **Off-site analysis is necessary if changes in flows could impair or alter conveyance systems, streambanks, bed sediment or aquatic habitat. A ¼-mile downstream analysis may be required. See Chapter 4 for off-site analysis guidance.**
- **Where necessary to comply with Minimum Requirement #7, Stormwater retention/detention facilities shall be constructed as one of the first steps in grading. Detention facilities shall be functional prior to construction of site improvements (e.g. impervious surfaces).**
- **The City may require pond designs that provide additional or different stormwater flow control, if necessary, to address local conditions or to protect properties and waterways downstream from erosion due to increases in the volume, velocity, and peak flow rate of stormwater runoff from the project site.**

**If permanent infiltration ponds are used for flow control during construction, these facilities should be protected from siltation during the construction phase.**

***Element 4: Install Sediment Controls***

- **The duff layer, native topsoil, and natural vegetation shall be retained in an undisturbed state to the maximum extent practicable.**
- **Prior to leaving a construction site, or prior to discharge to an infiltration facility, stormwater runoff from disturbed areas shall pass through a sediment pond or other appropriate sediment removal BMP. Runoff from fully stabilized areas may be discharged without a sediment removal BMP, but must meet the flow control performance standard of Element #3, bullet #1. Full stabilization means concrete or asphalt paving; quarry spalls used as ditch lining; or the use of rolled erosion products, a bonded fiber matrix product, or vegetative cover in a manner that will fully prevent soil erosion. The City shall inspect and approve areas stabilized by means other than pavement or quarry spalls.**
- **Sediment ponds, vegetated buffer strips, sediment barriers or filters, dikes, and other BMPs intended to trap sediment on-site shall be constructed as one of the first steps in grading. These BMPs shall be functional before other land disturbing activities take place.**
- **Earthen structures such as dams, dikes, and diversions shall be seeded and mulched according to the timing indicated in Element #5.**

***Element 5: Stabilize Soils***

- **All exposed and unworked soils shall be stabilized by application of effective BMPs, that protect the soil from the erosive forces of raindrop impact and flowing water, and wind erosion.**

- From October 1 through April 30, no soils shall remain exposed and unworked for more than 2 days. From May 1 to September 30, no soils shall remain exposed and unworked for more than 7 days. This condition applies to all soils on site, whether at final grade or not.
- Applicable practices include, but are not limited to, temporary and permanent seeding, sodding, mulching, plastic covering, soil application of polyacrylamide (PAM), early application of gravel base on areas to be paved, and dust control.
- Soil stabilization measures selected should be appropriate for the time of year, site conditions, estimated duration of use, and potential water quality impacts that stabilization agents may have on downstream waters or ground water.
- Soil stockpiles must be stabilized and protected with sediment trapping measures.
- Work on linear construction sites and activities, including right-of-way and easement clearing, roadway development, pipelines, and trenching for utilities, shall not exceed the capability of the individual contractor for his portion of the project to install the bedding materials, roadbeds, structures, pipelines, and/or utilities, and to re-stabilize the disturbed soils, meeting the timing conditions listed above.

***Element 6: Protect Slopes***

In addition to the requirements that might apply from Chapter 13.11 - Critical Areas Preservation Ordinance and Chapter 2.02.330- Excavation and Grading Ordinance of the Tacoma Municipal Code the following are requirements of element 6.

- Cut and fill slopes shall be designed and constructed in a manner that will minimize erosion.
- Consider soil type and its potential for erosion.
- Reduce slope runoff velocities by reducing the continuous length of slope with terracing and diversions, reduce slope steepness, and roughen slope surface.
- Divert drainage from the top of slope by intercepting all flows. Off-site stormwater should be handled separately from stormwater generated on the site. Diversion of off-site stormwater around the site may be a viable option. Diverted flows shall be redirected to the natural drainage location at or before the property boundary.
- Flows on the slope should be collected in pipes, slope drains, or protected channels.
- Provide drainage to remove ground water at the point it intersects the exposed slope surface.

- Excavated material shall be placed on the uphill side of trenches, consistent with safety and space considerations.
- Check dams shall be placed at regular intervals within trenches that are cut down a slope.
- Stabilize soils on slopes, as specified in Element #5.

***Element 7: Protect Drain Inlets***

- All storm drain inlets made operable during construction shall be protected so that stormwater runoff shall not enter the conveyance system without first being filtered or treated to remove sediment.
- All approach roads shall be kept clean, and all sediment and street wash water shall not be allowed to enter storm drains without prior and adequate treatment unless treatment is provided before the storm drain discharges to waters of the State.

***Element 8: Stabilize Channels and Outlets***

- All temporary on-site conveyance channels shall be designed, constructed and stabilized to prevent erosion from the expected velocity of flow from a 2 year, 24-hour frequency storm for the developed condition. See Chapter 4 of Volume III.
- Stabilization, including armoring material, adequate to prevent erosion of outlets, adjacent streambanks, slopes and downstream reaches shall be provided at the outlets of all conveyance systems.

***Element 9: Control Pollutants***

- All pollutants, including waste materials and demolition debris, that occur on-site during construction shall be handled and disposed of in a manner that does not cause contamination of stormwater.
- Cover, containment, and protection from vandalism shall be provided for all chemicals, liquid products, petroleum products, and non-inert wastes present on the site (see Chapter 173-304 WAC for the definition of inert waste).
- Maintenance and repair of heavy equipment and vehicles involving oil changes, hydraulic system drain down, solvent and de-greasing cleaning operations, fuel tank drain down and removal, and other activities which may result in discharge or spillage of pollutants to the ground or into stormwater runoff must be conducted using spill prevention measures, such as drip pans. Contaminated surfaces shall be cleaned immediately following any discharge or spill incident. Emergency repairs may be performed on-site using temporary plastic placed beneath and, if raining, over the vehicle.
- Wheel wash, or tire bath wastewater, shall be discharged to a separate on-site treatment system or to the sanitary sewer. All

discharges to the City sewer system (storm or sanitary) require prior City approval. Discharges to the City sewer system may require a separate Special Approved Discharge permit.

- Application of agricultural chemicals, including fertilizers and pesticides, shall be conducted in a manner and at application rates that will not result in loss of chemical to stormwater runoff. Manufacturers' recommendations shall be followed for application rates and procedures.
- Management of pH-modifying sources shall prevent contamination of runoff and stormwater collected on the site. These sources include, but are not limited to, bulk cement, cement kiln dust, fly ash, new concrete washing and curing waters, waste streams generated from concrete grinding and sawing, exposed aggregate processes, and concrete pumping and mixer washout waters.

#### ***Element 10: Control De-Watering***

- All foundation, vault, and trench de-watering water, which has similar characteristics to stormwater runoff at the site, shall be discharged into a conveyance system, prior to discharge to a sediment trap or sediment pond. Channels must be stabilized, as specified in Element #8.
- Clean, non-turbid de-watering water, such as well-point ground water, can be discharged to systems tributary to state surface waters, as specified in Element #8, provided the de-watering flow does not cause erosion or flooding of the receiving waters. These clean waters should not be routed through sediment ponds with stormwater.
- Highly turbid or otherwise contaminated dewatering water, such as from construction equipment operation, clamshell digging, concrete tremie pour, or work inside a cofferdam, shall be handled separately from stormwater at the site.
- Other disposal options, depending on site constraints, may include: 1) infiltration, 2) transport off-site in vehicle, such as a vacuum flush truck, for legal disposal in a manner that does not pollute state waters, 3) on-site treatment using chemical treatment or other suitable treatment technologies, or 4) sanitary sewer discharge with City approval if there is no other option.
- All discharges to the City sewer system (storm or sanitary) require prior City approval. Discharges to the City sewer system may require a separate Special Approved Discharge permit.

#### ***Element 11: Maintain BMPs***

- All temporary and permanent erosion and sediment control BMPs shall be maintained and repaired as needed to assure



continued performance of their intended function. All maintenance and repair shall be conducted in accordance with BMPs.

- Sediment control BMPs shall be inspected weekly or after a runoff-producing storm event during the dry season and daily during the wet season.
- All temporary erosion and sediment control BMPs shall be removed within 30 days after final site stabilization is achieved or after the temporary BMPs are no longer needed. Trapped sediment shall be removed or stabilized on site. Disturbed soil areas resulting from removal of BMPs or vegetation shall be permanently stabilized.

#### ***Element 12: Manage The Project***

- **Phasing of Construction** - Development projects shall be phased in order to prevent, the transport of sediment from the development site during construction unless the applicant can demonstrate construction phasing is infeasible. Revegetation of exposed areas and maintenance of that vegetation shall be an integral part of the clearing activities for any phase.

Clearing and grading activities for developments shall be permitted only if conducted pursuant to an approved site development plan (e.g., subdivision approval) that establishes permitted areas of clearing, grading, cutting, and filling. When establishing these permitted clearing and grading areas, consideration should be given to minimizing removal of existing trees and minimizing disturbance/compaction of native soils except as needed for building purposes. These permitted clearing and grading areas and any other areas required to preserve critical or sensitive areas, buffers, native growth protection easements, or tree retention areas as may be required by the City, shall be delineated on the site plans and the development site.

- **Seasonal Work Limitations** - From October 1 through April 30, clearing, grading, and other soil disturbing activities shall only be permitted if shown to the satisfaction of the City that silt-laden runoff will be prevented from leaving the construction site through a combination of the following:
  1. Site conditions including existing vegetative coverage, slope, soil type and proximity to receiving waters; and
  2. Limitations on activities and the extent of disturbed areas; and
  3. Proposed erosion and sediment control measures.

Based on the information provided, and/or local weather conditions, the City may expand or restrict the seasonal

limitation on site disturbance. If, during the course of any construction activity or soil disturbance during the seasonal limitation period, silt-laden runoff leaving the construction site causes a violation of the surface water quality standard or if clearing and grading limits or erosion and sediment control measures shown in the approved plan are not maintained, the City shall take enforcement action, including, but not limited to a warning, notice of violation, penalty, or stop-work order.

The following activities are exempt from the seasonal clearing and grading limitations:

1. Routine maintenance and necessary repair of erosion and sediment control BMPs;
  2. Routine maintenance of public facilities or existing utility structures that do not expose the soil or result in the removal of the vegetative cover to soil; and
  3. Activities where there is one hundred percent infiltration of surface water runoff within the site in approved and installed erosion and sediment control facilities.
- **Coordination with Utilities and Other Contractors** - The primary project proponent shall evaluate, with input from utilities and other contractors, the stormwater management requirements for the entire project, including the utilities, when preparing the Construction SWPPP.
  - **Inspection and Monitoring** - All BMPs shall be inspected, maintained, and repaired as needed to assure continued performance of their intended function.

A Certified Professional in Erosion and Sediment Control shall be identified in the Construction SWPPP and shall be on-site or on-call at all times. Certification may be through the Washington State Department of Transportation/Associated General Contractors (WSDOT/AGC) Construction Site Erosion and Sediment Control Certification Program or any equivalent local or national certification and/or training program.

Sampling and analysis of the stormwater discharges from a construction site may be necessary on a case-by-case basis to ensure compliance with standards. Monitoring and reporting requirements may be established by the City or Local Permitting Authority when necessary.

Whenever inspection and/or monitoring reveals that the BMPs identified in the Construction SWPPP are inadequate, due to the actual discharge of or potential to discharge a significant amount of any pollutant, the SWPPP shall be modified, as appropriate, in a timely manner.

- **Maintenance of the Construction SWPPP** - The Construction SWPPP shall be retained on-site or within reasonable access to the site. The Construction SWPPP shall be modified whenever

**there is a significant change in the design, construction, operation, or maintenance of any BMP. The City inspector shall be notified of any changes to the Construction SWPPP. The inspector may require a plan modification go through the City review process.**

***Objective***

To control erosion and prevent sediment and other pollutants from leaving the site during the construction phase of a project.

***Supplemental Guidelines***

If a Construction SWPPP is found to be inadequate (with respect to erosion and sediment control requirements), then the City may require other BMPs be incorporated into the design and implemented, as appropriate. The City may allow development of generic Construction SWPPPs that apply to commonly conducted public road activities, such as road surface replacement, that trigger this minimum requirement.

**3.5.3 Minimum Requirement #3: Source Control of Pollution**

**All known, available and reasonable source control BMPs shall be applied to all projects. Source control BMPs shall be selected, designed, and maintained according to this manual.**

***Objective***

The intent of source control BMPs is to prevent stormwater from coming in contact with pollutants. They are a cost-effective means of reducing pollutants in stormwater, and, therefore, should be a first consideration in all projects.

Source Control BMPs include Operational BMPs and Structural Source Control BMPs. See Volume IV for design details of these BMPs. For construction sites, see Volume II, Chapter 4.

Structural source control BMPs should be identified in the stormwater site plan and should be shown on site plans submitted for City review.

***Supplemental Guidelines***

An adopted and implemented basin plan or a Total Maximum Daily Load (TMDL, also known as a Water Clean-up Plan) may be used to develop more stringent source control requirements that are tailored to a specific basin. Where there are geographical specific requirements they appear in Chapter 2 of this volume.

#### **3.5.4 Minimum Requirement #4: Preservation of Natural Drainage Systems and Outfalls**

**Natural drainage patterns shall be maintained, and discharges from the project site shall occur at the natural location, to the maximum extent practicable. The manner by which runoff is discharged from the project site must not cause a significant adverse impact to downstream receiving waters and downgradient properties. All outfalls require energy dissipation.**

**As part of a submittal, the applicant shall identify the location of natural drainage, topography, historic drainage information and any potential impacts.**

##### ***Objective***

To preserve and utilize natural drainage systems to the fullest extent because of the multiple stormwater benefits these systems provide; and to prevent erosion at and downstream of the discharge location.

##### ***Supplemental Guidelines***

Creating new drainage patterns may result in more site disturbance and more potential for erosion and sedimentation during and after construction. Creating new discharge points can create significant stream channel erosion problems as the receiving water body typically must adjust to the new flows. Diversions can cause greater impacts than would otherwise occur by discharging runoff at the natural location. However, a project applicant may have rights to add surface flow to a natural drainway, or may acquire or have acquired rights to discharge flow to adjacent or downstream properties.

Where no natural drainway or available conveyance system exists at the adjacent downgradient property line and the discharge was previously unconcentrated flow or significantly lower concentrated flow, then the following are control measures that are recommended to prevent downgradient impacts:

- a) All site drainage should be conveyed to the City storm system. If necessary, the City may require a system consisting of curb, gutter, catch basins, manholes and storm drainage pipe to be extended to serve the project site.
- b) If the 100-year peak discharge is less than or equal to 0.2 cfs under existing conditions and will remain less than or equal to 0.2 cfs under developed conditions, then the concentrated runoff may be discharged onto a rock pad or to any other system that serves to disperse flows.
- c) If the 100-year peak discharge is less than or equal to 0.5 cfs under existing conditions and will remain less than or equal to 0.5 cfs under developed conditions, then the concentrated runoff may be

discharged through a dispersal trench or other dispersal system, provided the applicant can demonstrate that there will be no significant adverse impact to downhill properties or drainage systems.

- d) If the 100-year peak discharge is greater than 0.5 cfs for either existing or developed conditions, or if a significant adverse impact to downgradient properties or drainage systems is likely, then a conveyance system must be provided to convey the concentrated runoff across the downstream properties to an acceptable discharge point (i.e., an enclosed drainage system or open drainage feature where concentrated runoff can be discharged without significant adverse impact).

Stormwater control or treatment structures should not be located within the expected 25-year water level elevations for salmonid-bearing waters. Such areas may provide off-channel habitat for juvenile salmonids and salmonid fry. Designs for outfall systems to protect against adverse impacts from concentrated runoff are included in Volume V, Chapter 4.

Any options selected from the above shall be confirmed through design submittals meeting both Minimum Requirement #5 - On-site Stormwater Management and Additional Requirement #1 - Off-site Analysis. For specific design requirements refer to Volume III, Chapter 4 – Conveyance Analysis and Design.

### **3.5.5 Minimum Requirement #5: On-Site Stormwater Management**

**The infiltration and dispersion systems described in this Minimum requirement shall only be used with the pre-approval of the City.**

**Projects shall employ, where feasible and appropriate, On-site Stormwater Management BMPs to infiltrate, disperse, and retain stormwater runoff onsite to the maximum extent feasible without causing flooding, erosion, water quality or groundwater impacts. Roof Downspout Control BMPs, functionally equivalent to those described in Chapter 3 of Volume III, and Dispersion and Soil Quality BMPs, functionally equivalent to those in Chapter 5 of Volume V, shall be required to reduce the hydrologic disruption of developed sites.**

**All sites proposing infiltration shall provide a design as part of a Stormwater Site Plan submitted to the City for review. The design shall be provided by a certified soils professional or professional engineer. Adequate soils information meeting the analysis requirements of Volume III, Chapter 3 and Volume V, Chapter 7 shall be provided with all proposed infiltration facilities.**

**All sites proposing dispersion techniques shall follow the design requirements of Volume III, Section 3.1.3 – Downspout Dispersion. Although not required, the City recommends a professional design the dispersion systems.**

**Infiltration and dispersion require pre-approval by the City. The following items can help the designer determine whether On-site Stormwater Management may be appropriate:**

- **Infiltration should only be used for urban lots (≥8000 square feet) with soils that readily infiltrate (coarse sands and cobbles to medium sands).**
- **Dispersion BMPs should be used for urban lots (≥8000 square feet) located in less permeable soils, if infiltration is not feasible.**
- **Where infiltration or dispersion is not feasible because of very small lot size (<8,000 square feet), impermeable soils, or where there is a potential for creating drainage problems on adjacent lots, downspouts shall be connected to the City storm system. If the storm system is not directly adjacent to the property, the system shall be extended at the proponent's expense.**
- **Where "geologically hazardous areas" (WAC 365-195-410), potential flooding, erosion impacts, water quality impacts or groundwater impacts have been identified, infiltration and dispersion systems are prohibited.**
- **Discharges from Pollution Generating Impervious Surfaces to the Groundwater Protection District (Tacoma Municipal Code and as defined in Chapter 2 of this Volume) are prohibited. Discharges of non-polluted waters to the groundwater in the Groundwater Protection District require pre-approval by the City with regard to appropriateness.**

### ***Objective***

*To use inexpensive practices on individual properties to reduce the amount of disruption of the natural hydrologic characteristics of the site.*

### ***Supplemental Guidelines***

Other innovative stormwater management BMPs such as rain barrels, ornamental ponds, downspout cisterns, may also be used if approved by the City.

On-site stormwater management BMPs may not create or contribute to flooding, erosion, water quality or groundwater impacts.

"Flooding, erosion, water quality and groundwater impacts" include impacts such as flooding of septic systems, crawl spaces, living areas, outbuildings, etc.; increased ice or algal growth on sidewalks/roadways; earth movement/settlement, increased landslide potential; erosion and other potential damage; and contamination of groundwater.

Recent research indicates that current techniques in residential, commercial, and industrial land development can cause gross disruption of the natural hydrologic cycle with severe impacts to water and water-

related natural resources. Based upon gross level applications of continuous runoff modeling and assumptions concerning minimum flows needed to maintain beneficial uses, watersheds must retain the majority of their natural vegetation cover and soils, and developments must meet the Flow Control Minimum Requirement of this chapter, in order to avoid significant natural resource degradation in lowland streams.

The Roof Downspout Control BMPs described in Chapter 3 of Volume III, and the Dispersion and Soil Quality BMPs in Chapter 5 of Volume V are insufficient to prevent significant hydrologic disruptions and impacts to streams and their natural resources. Therefore, Ecology has suggested that the City and other local governments should look for opportunities to encourage and require additional BMPs such as those in Sections 5.2 through 5.4 of Volume V through updates to their site development standards and land use plans.

### **3.5.6 Minimum Requirement #6: Runoff Treatment**

#### ***Thresholds***

The following require construction of stormwater treatment facilities (see Table 3.1):

- **Projects in which the total of effective pollution-generating impervious surface (PGIS) is 5,000 square feet or more in a threshold discharge area of the project, or**
- **Projects in which the total of pollution-generating pervious surfaces (PGPS) is three-quarters (3/4) of an acre or more in a threshold discharge area, and from which there is a surface discharge in a natural or man-made conveyance system from the site.**

#### ***Treatment Facility Sizing***

**Water Quality Design Storm Volume:** The volume of runoff predicted from a 24-hour storm with a 6-month return frequency (a.k.a., 6-month, 24-hour storm). Wetpool facilities are sized based upon the volume of runoff predicted through use of the Natural Resource Conservation Service curve number equations in Chapter 2 of Volume III, for the 6-month, 24-hour storm.

#### **Water Quality Design Flow Rate:**

- ***Preceding Detention Facilities or when Detention Facilities are not required:*** The flow rate at or below which 91% of the runoff volume will be treated, as estimated by an approved continuous runoff model. Design criteria for treatment facilities are assigned to achieve the applicable performance goal at the water quality design flow rate.
- **Volume V includes performance goals for Basic, Enhanced, Phosphorus, and Oil Control treatment, and a menu of facility options for each treatment type. Treatment facilities that are**

selected from the appropriate menu and designed in accordance with their design criteria are presumed to meet the applicable performance goals.

- ***Downstream of Detention Facilities:*** The full 2-year release rate from the detention facility.

Alternative methods can be used if they identify volumes and flow rates that are at least equivalent.

That portion of any development project in which the above PGIS or PGPS thresholds are not exceeded in a threshold discharge area shall apply On-site Stormwater Management BMPs, where feasible, in accordance with Minimum Requirement #5.

#### ***Treatment Facility Selection, Design, and Maintenance***

Stormwater treatment facilities shall be:

- Selected in accordance with the process identified in Chapter 5 of Volume I;
- Designed in accordance with the design criteria in Volume V; and
- Maintained in accordance with the maintenance schedule in Volume V that shall be incorporated in the design as part of a facility operation and maintenance manual.

#### ***Additional Requirements***

Direct discharge of untreated stormwater from pollution-generating impervious surfaces to ground water is prohibited, except for the discharge achieved by infiltration or dispersion of runoff from residential sites through use of On-site Stormwater Management BMPs in accordance with Minimum Requirement #5.

#### ***Objective***

The purpose of runoff treatment is to reduce pollutant loads and concentrations in stormwater runoff using physical, biological, and chemical removal mechanisms so that beneficial uses of receiving waters are maintained and, where applicable, restored. When site conditions are appropriate, infiltration can potentially be the most effective BMP for runoff treatment.

#### ***Supplemental Guidelines***

See Volume V for more detailed guidance on selection, design, and maintenance of treatment facilities. The water quality design storm volume and flow rates are intended to capture and effectively treat about 90-95% of the annual runoff volume in western Washington. See Appendix I-B for background on their derivation.



An adopted and implemented basin plan, or a Total Maximum Daily Load (TMDL - also known as a Water Clean-up Plan) may be used to develop runoff treatment requirements that are tailored to a specific basin. Requirements applicable to specific basins in Tacoma appear in Chapter 2 of this volume. However, treatment requirements shall not be less than that achieved by facilities in the Basic Treatment Menu (see Volume V, Chapter 3).

Treatment facilities applied consistent with this manual are presumed to meet the requirement of state law to provide all known available and reasonable methods of treatment (RCW 90.52.040, RCW 90.48.010). This technology-based treatment requirement does not excuse any discharge from the obligation to apply whatever technology is necessary to comply with state water quality standards, Chapter 173-201A WAC; state ground water quality standards, Chapter 173-200 WAC; state sediment management standards, Chapter 173-204 WAC; and the underground injection control program, Chapter 173-218 WAC. Additional treatment to meet those standards may be required by federal, state, or local governments.

Infiltration through use of On-site Stormwater Management BMPs can provide both treatment of stormwater, through the ability of certain soils to remove pollutants, and volume control of stormwater, by decreasing the amount of water that runs off to surface water. Infiltration through engineered treatment facilities that utilize the natural soil profile can also be very effective at treating stormwater runoff, but pretreatment must be applied and soil conditions must be appropriate to achieve effective treatment while not impacting ground water resources. See Chapter 6 of Volume V for design details.

Discharge of pollution-generating surfaces into an engineered infiltration system, after pretreatment, can be acceptable if the soil conditions provide sufficient treatment capacity. Infiltration systems discharging into gravelly soils are not likely to have sufficient treatment capability. They must be preceded by at least a basic treatment BMP. See Volume V, Chapters 2 and 7 for details.

Impervious surfaces that are “fully dispersed” in accordance with BMP T5.30 in Volume V are not considered effective impervious surfaces. PGIS surfaces that are “dispersed” in accordance with the BMPs in Section 5.1 of Volume V are considered effective impervious surfaces. Porous pavers and Modular grid pavements are assigned a lower curve number (if using single event hydrology to size wetpools) and lower surface runoff calibrations (if using continuous runoff modeling). See Volume III for a more complete description of hydrologic credits for Onsite Stormwater Management BMPs.

### **3.5.7 Minimum Requirement #7: Flow Control**

#### **3.5.7.1 - Applicability**

Projects must provide flow control to reduce the impacts of stormwater runoff from impervious surfaces and land cover conversions. For geographic specific flow control requirements refer to Chapter 2 of Volume 1. The flow control requirement thresholds in Section 3.5.7.3 below apply to projects that discharge directly or indirectly:

- Through a conveyance system, into a fresh water; or
- Through a conveyance system into a gulch; or
- To a City identified capacity problem existing downstream of the development; or
- To a manmade conveyance system (ditch, swale, etc.) which has not been adequately stabilized to prevent erosion; or
- To a conveyance system without capacity to convey the fully developed design event as defined in Chapter 4 of Volume III.

Please see Figure 3.4. for a descriptive flow chart of the flow control requirements.

#### **3.5.7.2 – Exemptions**

The standard requirement of 3.5.7.3 does not apply to:

discharges into a wetland (See Minimum Requirement #8 for flow control requirements applicable to discharges to wetlands);

discharges for which geographic specific requirements apply in accordance with Chapter 2 of Volume 1.

Any areas for which the standard requirement does not apply must still meet the following criteria:

- The project must be drained by a conveyance system with capacity to convey the fully developed design event as defined in Chapter 4 of Volume III. The conveyance system must be comprised entirely of manmade conveyance elements (e.g., pipes, ditches, outfall protection, etc.) and extends to the ordinary high water line of the receiving water; and
- Any erodible elements of the manmade conveyance system for the area must be adequately stabilized to prevent erosion; and
- No City identified capacity problems may exist downstream of the development; and
- Surface water from the area must not be diverted from or increased to an existing wetland, stream, or near-shore habitat sufficient to cause a significant adverse impact.

### **3.5.7.3 - Thresholds**

If flow control is required per section 3.4.1 and 3.4.2 (new and redevelopment), the flow control thresholds (Table 3.2) of this section apply. Flow control facilities shall be designed for the new impervious surfaces, the new plus replaced impervious surfaces, and any converted pervious surfaces. The design will achieve the standard requirement for Western Washington as stated later in this section.

That portion of any development project in which the thresholds listed below are not exceeded in a threshold discharge area, shall apply Onsite Stormwater Management BMPs in accordance with Minimum Requirement #5.

#### ***Standard Requirement***

Stormwater discharges shall match developed discharge durations to predeveloped durations for the range of predeveloped discharge rates from 50% of the 2-year peak flow up to the full 50-year peak flow.

The pre-developed condition to be matched shall be a forested land cover unless reasonable, historic information is provided that indicates the site was prairie prior to settlement (modeled as “pasture” in the Western Washington Hydrology Model). This standard requirement is waived for sites that will reliably infiltrate all the runoff from impervious surfaces and converted pervious surfaces.

#### ***Objective***

To prevent increases in the stream channel erosion rates that are characteristic of natural conditions (i.e., prior to disturbance by European settlement). The standard intends to maintain the total amount of time that a receiving stream exceeds an erosion-causing threshold based upon historic rainfall and natural land cover conditions. That threshold is assumed to be 50% of the 2-year peak flow. Maintaining the naturally occurring erosion rates within streams is vital, though by itself insufficient, to protect fish habitat and production.

### **3.5.7.4 – Modeling Guidelines**

Reduction of flows through infiltration decreases stream channel erosion and helps to maintain base flow throughout the summer months. However, infiltration should only be used where ground water quality is not threatened by such discharges.

Volume III includes a description of the Western Washington Hydrology Model. The model provides credits for use of certain downspout designs and other types of Onsite Stormwater Management BMPs described in

Volume V. Using those BMPs reduces the size of the required flow control facilities.

Application of sufficient types of Onsite Stormwater Management BMPs can result in reducing the effective impervious area and the converted pervious areas such that a flow control facility is not required. Application of "Full Dispersion", BMP T5.30, also results in eliminating the flow control facility requirement for those areas that are "fully dispersed."

The City of Tacoma will allow the use of Ecology's interim design guidelines until such a time as Ecology has completed the flow routing module for their continuous rainfall/runoff model. The City will allow use of a peak flow standard that approximates the results that the proposed flow duration standard would achieve as described below.

### ***Interim Modeling Guidelines***

**The applicant may use either the Department of Ecology's WWHM model (See Volume III) with associated spreadsheets or flow routing programs to size the treatment facilities and BMPs. OR**

**Instead of using Ecology's model, the applicant may use the guidelines below to modify the Santa Barbara Urban Hydrograph (SBUH) hydraulic analysis method to meet the flow duration standard. There are several acceptable computer models available that will perform the SBUH hydraulic analysis, however, the designer shall use the most current version of any software proposed within 1 year of the version's release. The designer shall provide a copy of the completed variable checklist (Appendix I-G) that will provide the reviewer a complete list of input values for the project model.**

*Note: Hand-calculated hydrographs and flow routing will no longer be accepted because of the wide availability of various software programs.*

**By adjusting the target peak flow standard, restricting the use of variables in the Santa Barbara Urban Hydrograph (SBUH) hydrologic analysis, and applying a volume correction factor, one can estimate the orifice sizes and detention volumes that the proposed flow duration standard would indicate. The following explains how to adjust the SBUH approach to obtain results similar to the output from the King County Runoff Time Series (an application of the Hydrologic Simulation Program – Fortran) with the proposed flow duration standard as the target.**

**Adjusted target peak flow standard.** Limit the peak rate of runoff from individual development sites to 50 percent of the pre-developed condition 2-year, 24-hour design storm. Limit the peak rate from the 10-year, 24-hour design storm to the pre-developed condition peak rate from the 2-year, 24-hour design storm. Limit the peak rate from the 100-year, 24-

hour design storm to the pre-developed condition peak rate from the 10-year, 24-hour design storm.

**Restricted variable assumptions.** The flow path length assumed for sheet flow runoff in the pre-developed condition calculations must not be less than 300 feet.

The Manning's effective roughness coefficient for pre-developed forested conditions should be 0.80. For pasture conditions, the coefficient should be 0.15.

In the table of curve numbers in Volume III, Chapter 2, the curve numbers for pre-developed forest and pasture conditions must be selected from the "fair" category.

**Volume correction factor:** In addition to the above, the pond volume correction factor (applicable to detention and retention facilities) identified in Volume III, Chapter 2 should be used where the pre-developed condition is modeled as pasture. When enlarging the pond to accommodate the volume correction factor, remember to not change the pond depth or the design of the outlet structure. Thus, an increase in the surface area is necessary.

### **3.5.8 Minimum Requirement #8: Wetlands Protection**

#### ***Applicability***

**The requirements below apply only to projects whose stormwater discharges into a wetland, either directly or indirectly through a conveyance system. These requirements must be met in addition to meeting Minimum Requirement #6, Runoff Treatment.**

#### ***Thresholds***

**The thresholds identified in Minimum Requirement #6 – Runoff Treatment, and Minimum Requirement #7 – Flow Control shall also be applied for discharges to wetlands.**

#### ***Standard Requirement***

**Discharges to wetlands shall maintain the hydrologic conditions, hydrophytic vegetation, and substrate characteristics necessary to support existing and designated uses. A wetland can be considered for hydrologic modification and/or stormwater treatment in accordance with Guide Sheet 1B in Appendix I-D.**

#### ***Additional Requirements***

**The standard requirement does not excuse any discharge from the obligation to apply whatever technology is necessary to comply with state water quality standards, Chapter 173-201A WAC, or state**

**ground water standards, Chapter 173-200 WAC. Additional treatment requirements to meet those standards may be required by federal, state, or local governments.**

**Stormwater treatment and flow control facilities ordinarily are not constructed within a natural vegetated buffer, except for:**

- **Necessary conveyance systems as approved by the City; or**
- **As allowed in wetlands approved for hydrologic modification and/or treatment in accordance with Guidesheet 1B.**

**An adopted and implemented basin plan (Minimum Requirement #9), or a Total Maximum Daily Load (TMDL, also known as a Water Clean-up Plan) may be used to develop requirements for wetlands that are tailored to a specific basin. Requirements for specific basins within Tacoma are listed in Chapter 2 of this volume.**

### ***Objective***

To ensure that wetlands receive the same level of protection as any other waters of the state. Wetlands are extremely important natural resources which provide multiple stormwater benefits, including ground water recharge, flood control, and stream channel erosion protection. They are easily impacted by development unless careful planning and management are conducted. Wetlands can be severely degraded by stormwater discharges from urban development due to pollutants in the runoff and also due to disruption of natural hydrologic functioning of the wetland system. Changes in water levels and the frequency and duration of inundations are of particular concern.

### ***Supplemental Guidelines***

Appendix I-D, "Wetlands and Stormwater Management Guidelines" is an amended version of Chapter 14 of the publication, "Wetlands and Urbanization, Implications for the Future", the final report of the Puget Sound Wetland and Stormwater Management Research Program, 1997. It should be used for discharges to natural wetlands and wetlands constructed as mitigation. The amendments were added to Guidesheets 1A, 2B, and 2C to improve clarity of intent and to make them compatible with the updated manual. While it is always necessary to pre-treat stormwater prior to discharge to a wetland, there are limited circumstances where wetlands may be used for additional treatment and detention of stormwater. These situations are considered in Guide Sheet 1B of the guidelines.

Note that if selective runoff bypass is an alternative being considered to maintain the hydroperiod, the hydrologic analysis must consider the impacts of the bypassed flow. For instance, if the bypassed flow is eventually directed to a stream, the flow duration standard, Minimum Requirement #7, applies to the bypass.

### **3.5.9 Minimum Requirement #9: Basin/Watershed Planning**

Projects may be subject to equivalent or more stringent minimum requirements for erosion control, source control, treatment, and operation and maintenance, and alternative requirements for flow control and wetlands hydrologic control as identified in changes to existing and new Basin/Watershed Plans. City and Regional Basin/Watershed plans shall evaluate and include, as necessary, retrofitting urban stormwater BMPs into existing development and/or redevelopment in order to achieve watershed-wide pollutant reduction and flow control goals that are consistent with requirements of the federal Clean Water Act. Standards developed from basin plans shall not modify any of the above minimum requirements until the basin plan is formally adopted and implemented by the local governments within the basin, and approved or concurred with by Ecology. Where geographic specific requirements have been identified, they appear in Chapter 2. Future additional requirements developed as a result of Basin Planning will be added to Chapter 2.

#### ***Objective***

To promote watershed-based planning as a means to develop and implement comprehensive, water quality protection measures. Primary objectives of basin planning are to reduce pollutant loads and hydrologic impacts to surface and ground waters in order to protect beneficial uses.

### **3.5.10 Minimum Requirement #10: Operation and Maintenance**

An operation and maintenance manual that is consistent with the provisions in Volume V of this manual shall be provided for all proposed stormwater facilities and BMPs at the time the plans are submitted for review, and the party (or parties) responsible for maintenance and operation shall be identified.

At private facilities, a copy of the manual shall be retained onsite or within reasonable access to the site, and shall be transferred with the property to the new owner. For private systems serving multiple lots within residential developments or other developments, a separate covenant or other guarantee of proper maintenance that can be recorded on title shall be provided and recorded.

For public facilities, a copy of the manual shall be retained in the appropriate department. A log of maintenance activity that indicates what actions were taken shall be kept and be available for inspection by the City.

#### ***Objective***

To ensure that stormwater control facilities are adequately maintained and operated properly.

### ***Supplemental Guidelines***

Inadequate maintenance is a common cause of failure for stormwater control facilities. The description of each BMP in Volumes II, III, and V includes a section on maintenance. Chapter 4 of Volume V includes a schedule of maintenance standards for drainage facilities.

## **3.6 Additional Requirements**

The City has adopted the following additional requirements as being in the best interest of the general public and the environment.

### **3.6.1 Additional Requirement #1: Off-Site Analysis and Mitigation**

**As required by the Minimum Requirements of this Chapter and the Geographic Specific Requirements of Chapter 2, development projects that discharge stormwater offsite shall submit an offsite analysis report that assesses the potential off-site impacts.**

**All projects shall perform a *qualitative* analysis downstream from the site.**

**A *quantitative* analysis will be required for all projects creating 10,000 square feet or more of new impervious area that do not provide detention per the standard requirements. Also, all projects that wish to make a contribution in lieu of providing flow control shall provide a quantitative analysis. The City may also require a quantitative analysis for any project deemed to need additional downstream information. .**

**Both a qualitative and quantitative analysis are further described in section 4.1.3.**

**The existing or potential impacts to be evaluated and mitigated as part of any off-site/downstream analysis shall include:**

- **Conveyance system capacity problems;**
- **Localized flooding;**
- **Aquatic habitat (wetlands) impacts**
- **Upland erosion impacts, including landslide hazards;**
- **Stream channel erosion at the outfall location;**
- **Impacts to surface water, groundwater, or sediment quality as identified in a Basin Plan, TMDL (Water Clean-up Plan), or other plan or document referenced in Chapter 2 including, but not limited, to the Urban Creek Assessment.**



### ***Qualitative Analysis:***

Projects shall be required to submit, with the permit application, a **qualitative analysis of each downstream system leaving a site. A qualitative analysis shall extend downstream for the entire flow path, from the project site to the receiving water, or up to one-quarter mile, whichever is less. If a receiving water is within one-quarter mile, the analysis shall extend within the receiving water to one-quarter mile from the project site. The analysis shall extend one-quarter mile beyond any improvements proposed as mitigation. The analysis must extend upstream to a point where any backwater effects created by the project cease. The analysis shall accomplish four tasks:**

#### **Task 1 – Define and map the study area**

Submit a site map showing property lines and a topographic map (at a minimum a USGS 1:24000 Quadrangle Topographic map) showing site boundaries, study area boundaries, downstream flowpath, and potential/existing problems.

#### **Task 2 – Review all available information on the study area**

This will include all available basin plans, ground water management area plans, drainage studies, floodplain/floodway FEMA maps, wetlands inventory maps, Critical Areas maps, stream habitat reports, salmon distribution reports, etc.

#### **Task 3 – Field inspect the study area**

The design engineer will physically inspect the existing on- and off-site drainage systems of the study area for each discharge location for existing or potential problems and drainage features. An initial inspection and investigation should include:

- Investigate problems reported or observed during the resource review.
- Locate existing/potential constrictions or capacity deficiencies in the drainage system.
- Identify existing/potential flooding problems.
- Identify existing/potential overtopping, scouring, bank sloughing, or sedimentation.
- Identify significant destruction of aquatic habitat (e.g., siltation, stream incision).
- Collect qualitative data on features such as land use, impervious surface, topography, soils, presence of streams, wetlands.
- Collect information on pipe sizes, channel characteristics, drainage structures.

- Identify all existing public and private easements through the project site and their corresponding widths.
- Verify tributary drainage areas identified in Task 1.
- Contact the local government office with drainage review authority, neighboring property owners, and residents about drainage problems.
- Note date and weather at time of inspection.

**Task 4 – Describe the drainage system, and its existing and predicted problems through observations and hydraulic modeling of the City specified design storm event described in Chapter 4 of Volume III.**

For each drainage system component (e.g., pipes, culverts, bridges, outfalls, ponds, vaults) the following shall be covered in the analysis: location, physical description, problems, and field observations.

All existing or potential problems (e.g., ponding water, erosion) identified in tasks 2 and 3 above shall be described. The descriptions will be used to determine adequate mitigation. The following information should be provided for each existing or potential problem:

- Magnitude of or damage caused by the problem
- General frequency and duration
- Return frequency of storm or flow when the problem occurs (may require quantitative analysis)
- Water elevation when the problem occurs
- Names and concerns of parties involved
- Current mitigation of the problem
- Possible cause of the problem
- Whether the project is likely to aggravate the problem or create a new one.

**Upon review of this analysis, the City may require mitigation measures deemed adequate to address the problems, or a quantitative analysis, depending upon the presence of existing or predicted flooding, erosion, or water quality problems, and on the proposed design of the onsite drainage facilities.**

***Quantitative Analysis:***

**A quantitative analysis will be required for all projects creating 10,000 square feet or more of new impervious area that do not provide detention per the standard requirements. Also, all projects that wish to make a contribution in lieu of providing flow control**

**shall provide a quantitative analysis. The City may also require a quantitative analysis for any project deemed to need additional downstream information.**

When required, the quantitative analysis shall provide information on the severity and frequency of an existing problem or the likelihood of creating a new problem. It will evaluate proposed mitigation intended to avoid aggravation of the existing problem and to avoid creation of a new problem. The analysis should repeat tasks 3 and 4 above using data including: profiles, topography, and software calculations providing the design information required to determine conveyance system capacity. See Volume III, Chapter 4 for capacity design and backwater analysis requirements.

### ***Objective***

To identify and evaluate offsite water quality, erosion, slope stability, and drainage impacts that may be caused or aggravated by a proposed project, and to determine measures for preventing impacts and for not aggravating existing impacts. Aggravated shall mean increasing the frequency of occurrence and/or severity of a problem.

### ***Supplemental Guidelines***

Some of the most common and potentially destructive impacts of land development are erosion of downgradient properties, localized flooding, and slope failures. These are caused by increased surface water volumes and changed runoff patterns. The City believes taking the precautions of offsite analysis could prevent substantial property damage and public safety risks.

### **3.6.2 Additional Requirement #2: Financial Liability**

**Performance bonding or other appropriate financial guarantees may be required for certain projects to ensure construction of drainage facilities in compliance with these standards. In addition, a project applicant may be required to post a financial guarantee of the satisfactory performance and maintenance of any drainage facilities.**

**Where required, the proponent shall submit a bond or other financial surety acceptable to the City to guarantee that the proponent will correct any defect or subsequent problem in a dedicated improvement, including the satisfactory functioning of the project's drainage system caused by improper design, faulty construction, poor housing construction practices, or other reasons as determined by the City. The guarantee shall not exceed 10% of the construction cost of the project as determined by the City through review of the Engineer's submitted cost estimate. The guarantee shall remain in effect for a period of 24 months from the time that the City accepts the storm drainage system for maintenance. The proponent shall remain financially responsible for any and all costs**

exceeding the amount of the original financial guarantee for the guarantee time period.

The guarantee shall be submitted to the City before the improvements are dedicated to the City or, if applicable, before the posted construction bond is released back to the proponent at the proponent's option.

***Objective***

To ensure that development projects have adequate financial resources to fully implement stormwater management plan requirements and that liability is not unduly incurred by the City.

### **3.7 Exceptions**

Exceptions to the Minimum Requirements may be requested, in writing, to allow a waiver, or a modification of a requirement or to permit an alternative requirement, prior to permit approval and construction. The Public Works Director may grant an exception following a documented finding that:

- The exception is likely to be equally protective of public health, safety and welfare, the environment, and public and private property, as the requirement from which an exception is sought.

**OR**

- There are special physical circumstances or conditions affecting the property such that substantial reasons exist for approving the requested exception and the exception will not cause significant harm. The substantial reasons include, but are not limited to:
  - The requirement to be imposed is not technically feasible; or
  - An emergency situations necessitates approval of the exception; or
  - The requirement would cause significant harm or threat of harm to the public health, safety or welfare, to the environment, or to public and private property; or
  - The strict application of these provisions would deprive the applicant of all reasonable use of the parcel of land in question.

### ***Supplemental Guidelines***

The decision to grant an exception is within the sole discretion of the City, and the Director shall only approve an exception to the extent it is necessary. The Director may require the applicant to submit a licensed engineer's report or analysis along with a request, in writing, for an exception. Exceptions are intended to maintain a necessary flexible working relationship between the City and applicants.

The approval of an exception shall not be construed to be an approval of any violation of any of the other provisions of the City's Municipal Code, or of any other valid law of any governmental entity having jurisdiction.

**Table 3.1 Treatment Requirements by Threshold Discharge Area**

	< ¾ acres of PGPS	≥ ¾ acres PGPS	< 5,000 sf PGIS	≥ 5,000 sf PGIS
Treatment Facilities		✓		✓
Onsite Stormwater BMPs	✓	✓	✓	✓

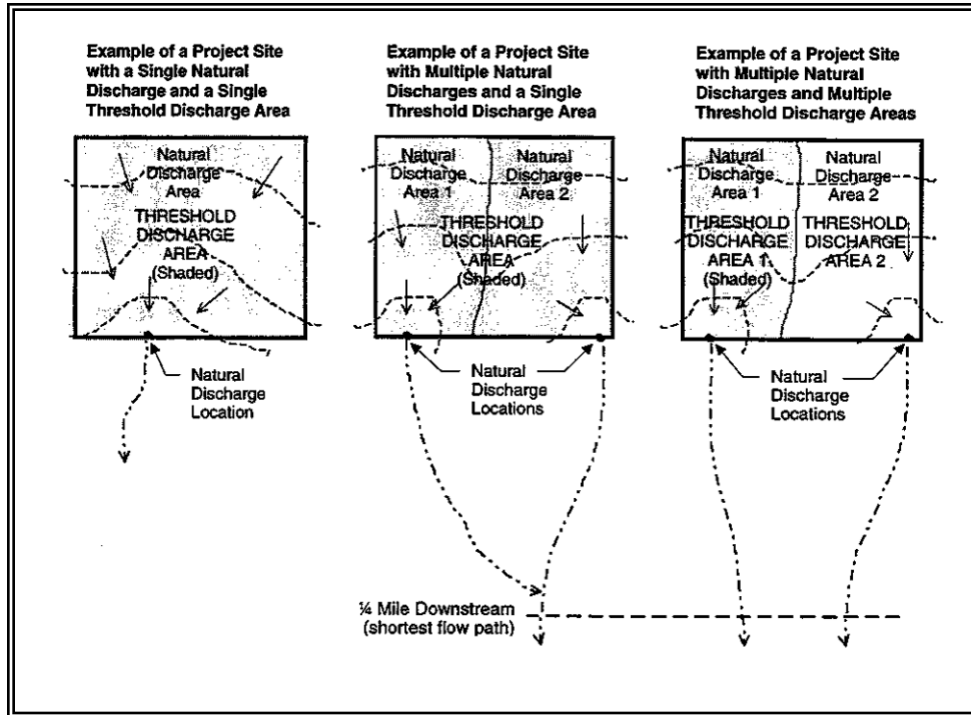
PGPS = pollution-generating pervious surfaces  
 PGIS = pollution-generating impervious surfaces  
 sf = square feet

**Table 3.2 Project Flow Control Requirements by Threshold Discharge Area**

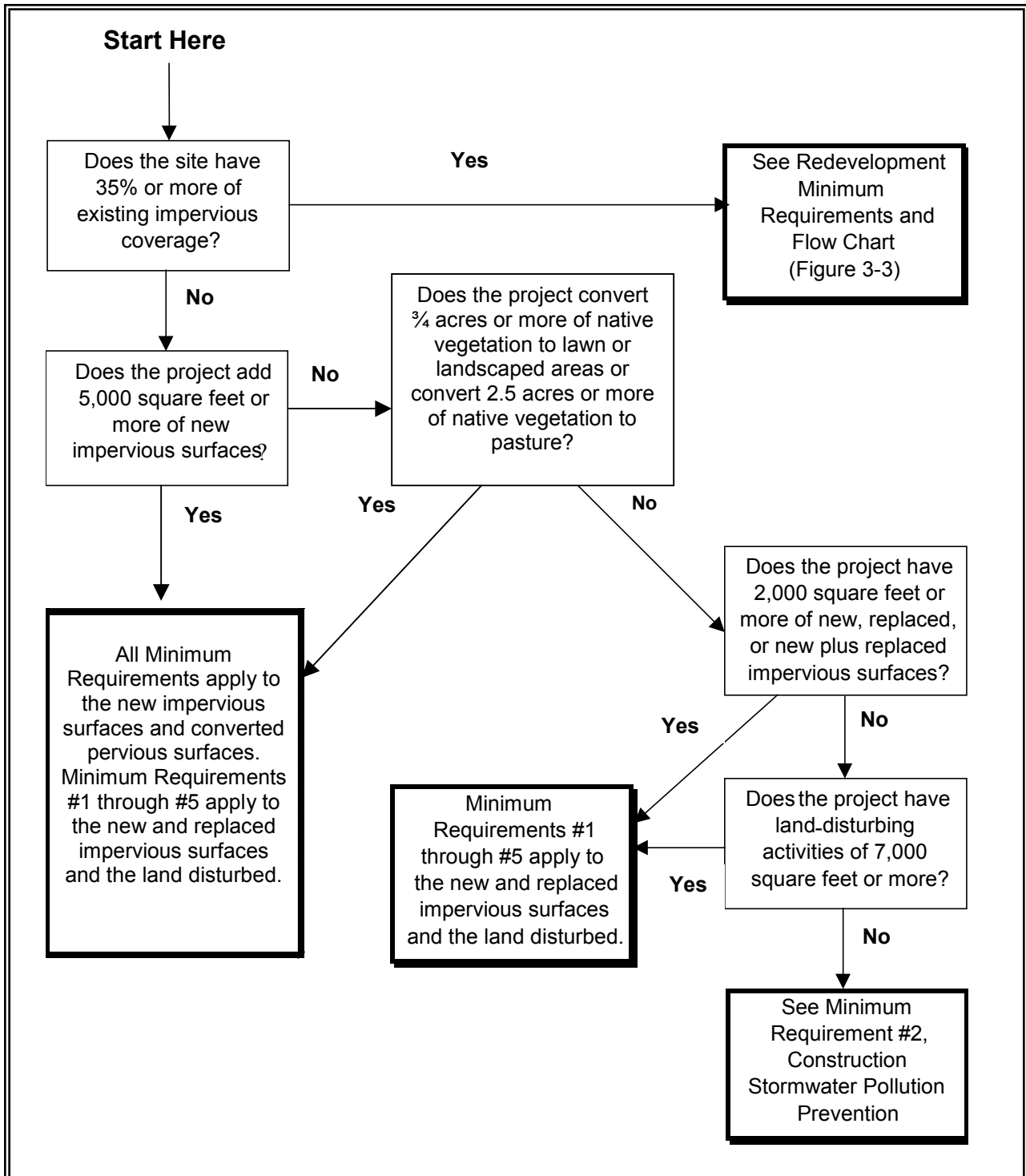
	Flow Control Facilities
< ¾ acres conversion of native vegetation to lawn/landscape, or < 2.5 acres of native vegetation to pasture	
≥ ¾ acres conversion of native vegetation to lawn/landscape, or ≥ 2.5 acres native vegetation to pasture <sup>2</sup>	✓
< 10,000 square feet of effective impervious area	
≥ 10,000 square feet of effective impervious area <sup>1</sup>	✓
≥ 0.1 cubic feet per second increase in the 100-year flood frequency <sup>3</sup>	✓
≥ 10,000 square feet or more of new impervious surface and an off-site analysis determines a downstream capacity problem exists or will result <sup>4</sup>	✓

1. Projects in which the total of effective impervious surfaces is 10,000 square feet or more in a threshold discharge area, or
2. Projects that convert ¾ acres or more of native vegetation to lawn or landscape, or convert 2.5 acres or more of native vegetation to pasture in a threshold discharge area, and from which there is a surface discharge in a natural or man-made conveyance system from the site, or
3. Projects that through a combination of effective impervious surfaces and converted pervious surfaces, cause a 0.1 cubic feet per second increase in the 100-year flow frequency from a threshold discharge area as estimated using the Western Washington Hydrology Model or other approved model.
4. Projects that create 10,000 square feet or more of new impervious surface and determine through an off-site analysis a downstream capacity problem exists or will result from the increased flows from the project.

Figure 3-1 Threshold Discharge Areas

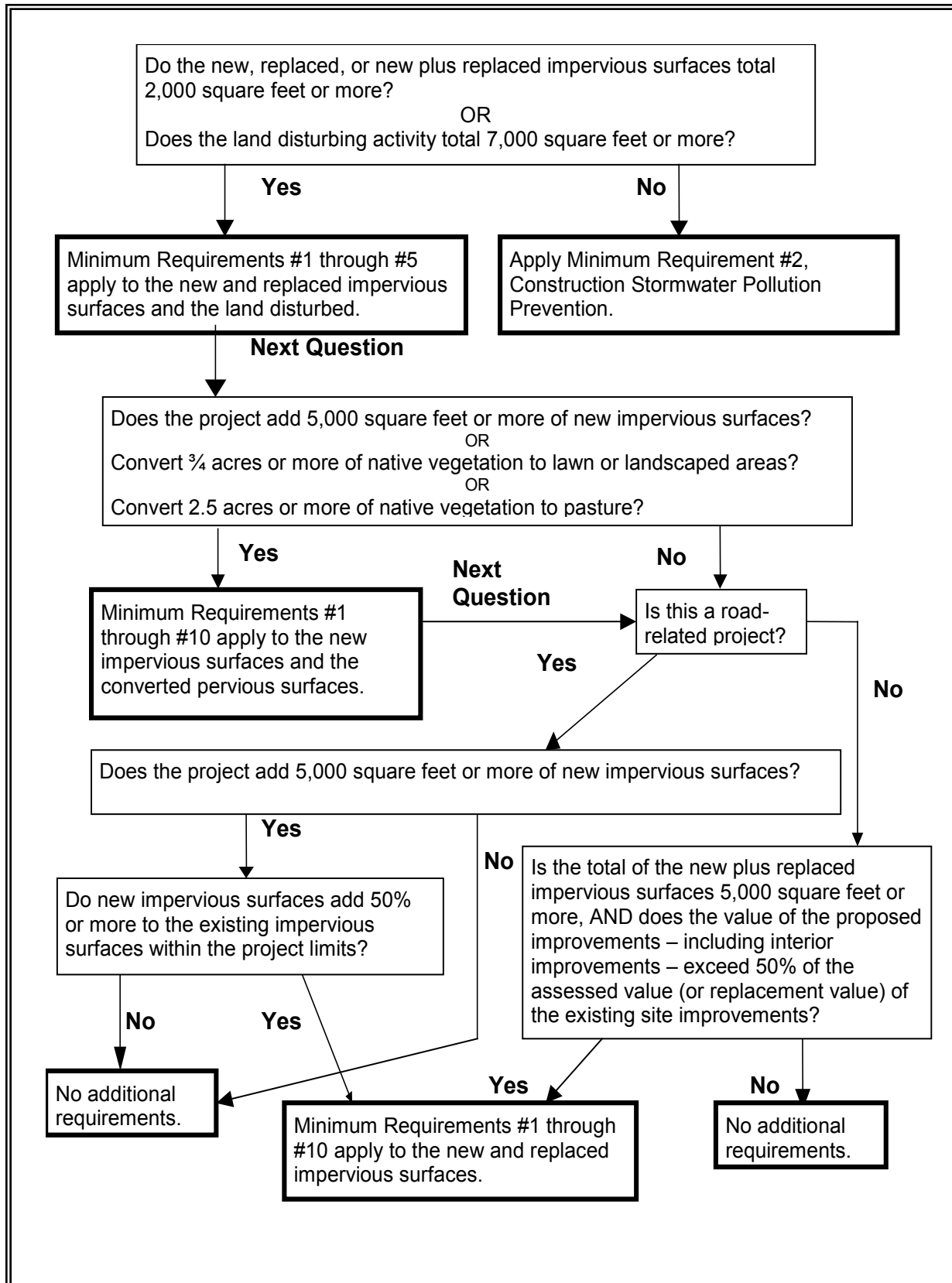


**Figure 3-2 Flow Chart for Determining Requirements for New Development**

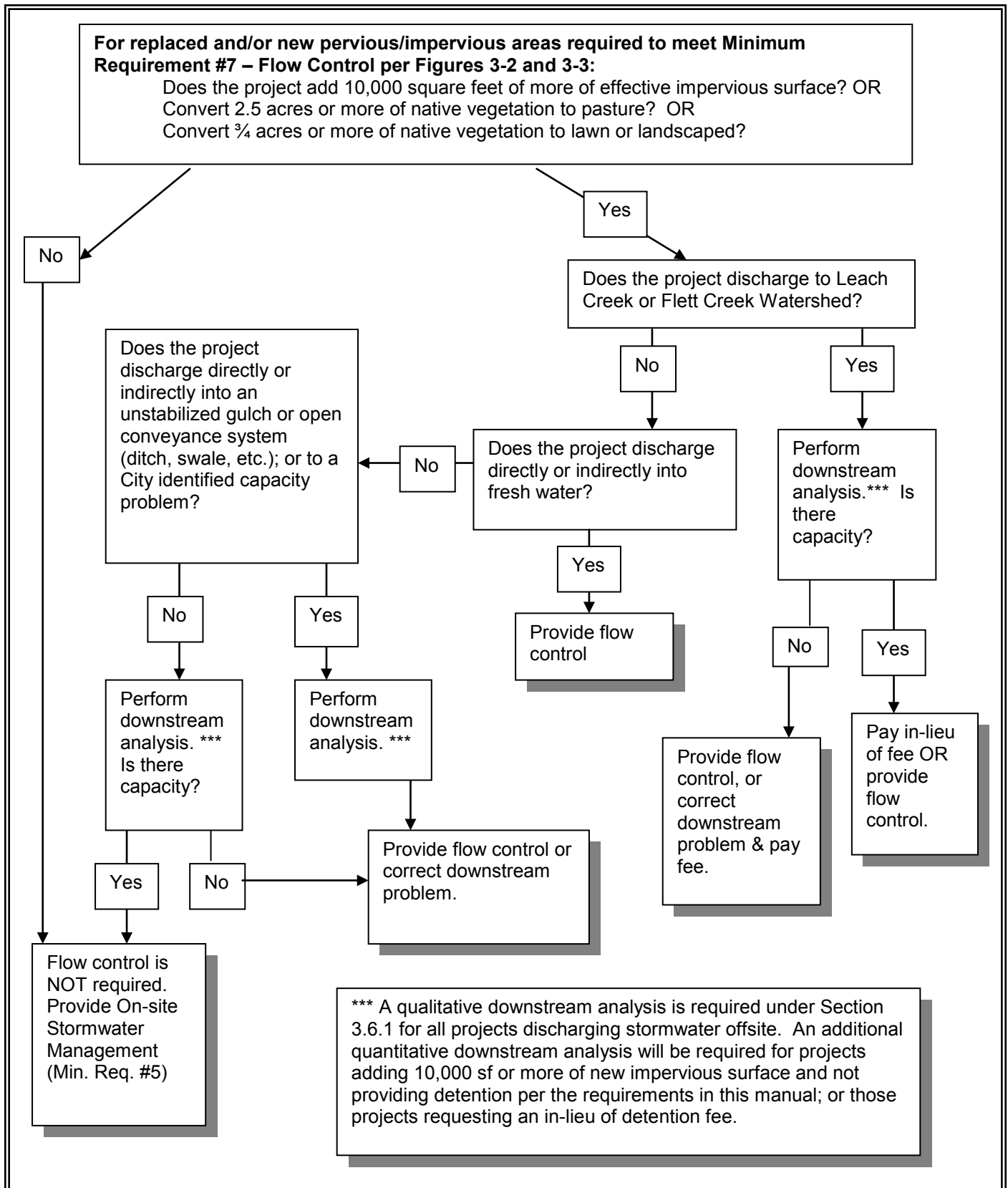




**Figure 3-3 Flow Chart for Determining Requirements for Redevelopment**



**Figure 3-4 - Flow Chart for Determining Flow Control for New Development and Redevelopment within a Given Threshold Discharge Area**



# Chapter 4 - Preparation of Stormwater Site Plans

---

The Stormwater Site Plan is the comprehensive report containing all of the technical information and analysis necessary for the City to evaluate a proposed new development or redevelopment project for compliance with stormwater requirements. This plan was previously known as a Drainage and Erosion Control Report. Contents of the Stormwater Site Plan will vary with the type and size of the project, and individual site characteristics. However, typical Stormwater Site Plans will contain both a report and detailed plans.

The scope of the Stormwater Site Plan also varies depending on the applicability of Minimum Requirements (see Section 3.4).

This chapter describes the contents of a Stormwater Site Plan and provides a general procedure for how to prepare the plan. The specific BMPs and design methods and standards to be used are contained in Volumes II-V. The content of, and the procedures for preparing a Construction Stormwater Pollution Prevention Plan (Construction SWPPP) are covered in detail in Chapter 3 of Volume II. Guidelines for selecting BMPs are given in Chapter 5 of this Volume.

The goal of this chapter is to provide a framework for uniformity in plan preparation. Such uniformity will promote predictability and help secure prompt review. Properly drafted engineering plans and supporting documents will also facilitate the operation and maintenance of the proposed system long after construction is complete.

***Note: To aid the design engineer, a checklist containing submittal requirements is located in Appendix I-E.***

State law requires that engineering work be performed by or under the direction of a professional engineer licensed to practice in Washington State. Plans involving construction of treatment facilities or flow control facilities (detention ponds or infiltration basins), structural source control BMPs, or drainage conveyance systems generally involve engineering principles and should be prepared by or under the direction of a licensed engineer. Construction Stormwater Pollution Prevention Plans (SWPPPs) that involve engineering calculations for sites greater than 1 acre must also be prepared by or under the direction of a licensed engineer.

## 4.1 Stormwater Site Plans: Step-By-Step

The steps involved in developing a Stormwater Site Plan are listed below.

1. Collect and Analyze Information on Existing Conditions
2. Prepare Preliminary Development Layout
3. Perform Off-site Analysis (as appropriate)
4. Determine Applicable Minimum Requirements

5. Prepare a Permanent Stormwater Control Plan
6. Prepare a Construction Stormwater Pollution Prevention Plan
7. Complete the Stormwater Site Plan
8. Check Compliance with All Applicable Minimum Requirements

The level of detail needed for each step depends upon the project size as explained in the individual steps. A narrative description of each of these steps follows.

#### **4.1.1 Step 1 – Collect and Analyze Information on Existing Conditions**

Collect and review information on the existing site conditions, including topography, drainage patterns, soils, ground cover, presence of any critical areas, adjacent areas, existing development, existing stormwater facilities, and adjacent on- and off-site utilities. Analyze data to determine site limitations including:

- Areas with high potential for erosion and sediment deposition (based on soil properties, slope, etc.); and
- Locations of sensitive and critical areas (e.g. vegetative buffers, wetlands, steep slopes, floodplains, geologic hazard areas, streams, etc.).

Delineate these areas on the vicinity map and/or a site map that are required as part of Step 7 – Completing a Stormwater Site Plan. Prepare an Existing Conditions Summary that will be submitted as part of the Site Plan. Part of the information collected in this step should be used to help prepare the Construction Stormwater Pollution Prevention Plan.

#### **4.1.2 Step 2 – Prepare Preliminary Development Layout**

Based upon the analysis of existing site conditions, locate the buildings, roads, parking lots, and landscaping features for the proposed development. Consider the following points when laying out the site:

- Fit development to the terrain to minimize land disturbance; Confine construction activities to the least area necessary, and away from critical areas;
- Preserve areas with natural vegetation (especially forested areas) as much as possible;
- On sites with a mix of soil types, locate impervious areas over less permeable soil (e.g., till), and try to restrict development over more porous soils (e.g., outwash);
- Cluster buildings together;
- Minimize impervious areas; and
- Maintain and utilize the natural drainage patterns.

The development layout designed here will be used for determining threshold discharge areas, for calculating whether size thresholds under Minimum Requirements #6, #7, and #8 are exceeded (see Chapter 3), and for the drawings and maps required for the Stormwater Site Plan.

#### **4.1.3 Step 3 – Perform an Offsite Analysis**

Section 3.6.1 establishes the requirements for an offsite analysis. For more information, see Section 3.6.1 and its associated flow chart (Figure 3.4).

#### **4.1.4 Step 4 – Determine and Read the Applicable Minimum Requirements**

Section 3.4 establishes project size thresholds for the application of Minimum Requirements to new development and redevelopment projects. Figures 3.2 and 3.3 provide the same thresholds in a flow chart format.

#### **4.1.5 Step 5 – Prepare a Permanent Stormwater Control Plan**

Select stormwater control BMPs and facilities that will serve the project site in its developed condition. This selection process is presented in detail in Chapter 5 of this Volume.

A preliminary design of the BMPs and facilities is necessary to determine how they will fit within and serve the entire preliminary development layout. After a preliminary design is developed, the designer may want to reconsider the site layout to reduce the need for construction of facilities, or the size of the facilities by reducing the amount of impervious surfaces created and increasing the areas to be left undisturbed. After the designer is satisfied with the BMP and facilities selections, the information must be presented within a Permanent Stormwater Control Plan. The Permanent Stormwater Control Plan should contain the following six sections:

##### **1. Permanent Stormwater Control Plan – Pre-developed Site Hydrology**

If flow control facilities are proposed to comply with Minimum Requirement #7, provide a listing of assumptions and site parameters used in analyzing the pre-developed site hydrology. The acreage, soil types, and land covers used to determine the pre-developed flow characteristics, along with basin maps, graphics, and exhibits for each sub-basin affected by the project should be included. The pre-developed condition to be matched shall be a forested land cover unless reasonable, historic information is provided that indicates the site was prairie prior to settlement.

Provide a topographic map, of sufficient scale and contour intervals to determine basin boundaries accurately, and showing:

- Delineation and acreage of areas contributing runoff to the site;
- Flow control facility location;

- Outfall;
- Overflow route; and
- All natural streams and drainage features.

The direction of flow, acreage of areas contributing drainage, and the limits of development should be indicated. Each basin within or flowing through the site should be named and model input parameters referenced.

## **2. Permanent Stormwater Control Plan – Developed Site Hydrology**

### **All Projects:**

Totals of impervious surfaces, pollution-generating impervious surfaces, and pollution generating pervious surfaces must be tabulated for each threshold discharge area for which On-site Stormwater Management BMPs are the sole stormwater management approach. These are needed to verify that the thresholds for application of treatment facilities (Minimum Requirements #6 and #8) and flow control facilities (Minimum Requirement #7 and #8) are not exceeded.

### **Projects and Threshold Discharge Areas within Projects That Require Treatment and Flow Control Facilities:**

Provide narrative, mathematical, and graphic presentations of model input parameters selected for the developed site condition, including acreage, soil types, and land covers, road layout, and all drainage facilities. The applicant shall reference sources for all variables and equations. All submissions shall be in typed format with a table of contents and labels for all figures and calculations. If calculations are used from other sections of the submittal, they shall be referenced with the appropriate, section and page number to the point of their original derivation.

Developed basin areas and flows shall be shown on a map and cross-referenced to computer printouts or calculation sheets. Developed basin flows should be listed and tabulated.

Any documents used to determine the developed site hydrology should be included. Maintain the same basin name as used for the pre-developed site hydrology. If the boundaries of a basin have been modified by the project, that should be clearly shown on a map and the name modified to indicate the change.

Final grade topographic maps shall be provided including finished floor elevations, where appropriate.

### **3. Permanent Stormwater Control Plan – Performance Standards and Goals**

If treatment facilities are proposed, provide a listing of the water quality menus used (Chapter 3, Volume V). If flow control facilities are proposed, provide a confirmation of the flow control standard being achieved (e.g., the Ecology flow duration standard).

### **4. Permanent Stormwater Control Plan – Flow Control System**

Provide a drawing of the flow control facility and its appurtenances. This drawing must show basic measurements necessary to calculate the storage volumes available from zero to the maximum head, all orifice/restrictor sizes and head relationships, control structure/restrictor placement, and placement on the site.

Include computer printouts, calculations, equations, references, storage/volume tables, graphs as necessary to show results and methodology used to determine the storage facility volumes. Where the Western Washington Hydrology Model is used, its documentation files should be included.

### **5. Permanent Stormwater Control Plan – Water Quality System**

Provide a drawing of the proposed treatment facilities, and any structural source control BMPs. The drawing must show overall measurements and dimensions, placement on the site, location of inflow, bypass, and discharge systems.

Include computer printouts, calculations, equations, references, and graphs as necessary to show the facilities are designed in accordance with the requirements and design criteria in Volume V.

*If using a manufactured system provide a specification from the manufacturer as well as all design specific parameters.*

### **6. Permanent Stormwater Control Plan – Conveyance System Analysis and Design**

Present an analysis of any existing conveyance systems, and the analysis and design of the proposed stormwater conveyance system for the project. Portions of this analysis may include the criteria established in Step 3 above. This information should be presented in a clear, concise manner that can be easily followed, checked, and verified. All pipes, culverts, catch basins, channels, swales, and other stormwater conveyance appurtenances must be clearly labeled and correspond directly to the engineering plans. The analysis should be based on the design elements within the City Design Manual and Volume III, Chapter 4 of the City Surface Water Design Manual.

#### **4.1.6 Step 6 – Prepare a Construction Stormwater Pollution Prevention Plan**

The Construction SWPPP for projects adding or replacing 2,000 square feet of impervious surface or more, or clearing 7,000 square feet or more, must contain sufficient information to satisfy the City that the potential pollution problems have been adequately addressed for the proposed project. An adequate Construction SWPPP is due prior to issuance of a development permit and will include a narrative and drawings. The narrative is a written statement to explain and justify the pollution prevention decisions made for a particular project. The narrative contains concise information concerning existing site conditions, construction schedules, and other pertinent items that are not contained on the drawings. The drawings and notes describe where and when the various BMPs should be installed, the performance the BMPs are expected to achieve, and actions to be taken if the performance goals are not achieved.

The 12 Elements listed below must be considered in the development of the Construction SWPPP unless site conditions render the element unnecessary and the exemption from that element is clearly justified in the narrative of the Construction SWPPP. These elements are described in detail in Section 3.5.2. They cover the general water quality protection strategies of limiting site impacts, preventing erosion and sedimentation, and managing activities and sources.

The 12 Elements are:

- Mark Clearing Limits
- Establish Construction Access
- Control Flow Rates
- Install Sediment Controls
- Stabilize Soils
- Protect Slopes
- Protect Drain Inlets
- Stabilize Channels And Outlets
- Control Pollutants
- Control Dewatering
- Maintain BMPs
- Manage the Project

A complete description and BMPs applicable to each element is given in Volume II, Chapter 3.



On construction sites that discharge to surface water, the primary consideration in the preparation of the Construction SWPPP is preventing damage to water quality. The step-by-step procedure outlined in Volume II, Section 3.2 is recommended for the development of these Construction SWPPPs. A checklist is contained in Volume II, Section 3.3 that may be helpful in preparing and reviewing the Construction SWPPP.

On construction sites that infiltrate all stormwater runoff, the primary consideration in the preparation of the Construction SWPPP is the protection of the infiltration facilities from fine sediments during the construction phase and protection of ground water from other pollutants. Several of the other elements are very important at these sites as well, such as marking the clearing limits, establishing the construction access, and managing the project.

#### **4.1.7 Step 7 – Complete the Stormwater Site Plan**

The Stormwater Site Plan encompasses the entire submittal to the City for drainage review. It includes the following documents:

##### **Project Overview**

The project overview must provide a general description of the project, predeveloped and developed conditions of the site, site area and size of the improvements, and the pre- and post-developed stormwater runoff conditions. The overview shall summarize difficult site parameters, the natural drainage system, and drainage to and from adjacent properties, including bypass flows.

The vicinity map shall clearly locate the property, identify all roads bordering the site, show the route of stormwater off-site to the local natural receiving water, and show significant geographic features and sensitive/critical areas (streams, wetlands, lakes, steep slopes, etc.).

Include a list of other necessary permits and approvals as required by other regulatory agencies, if those permits or approvals include conditions that affect the drainage plan, or contain more restrictive drainage-related requirements.

##### **Existing Conditions Summary**

This is the summary described in Section 4.1.1 above.

##### **Off-site Analysis**

This is the report described under Section 4.1.3 above.

##### **Permanent Stormwater Control Plan**

This is the plan described in Section 4.1.5 above.

### **Minimum Requirements Discussion**

Provide a list of the minimum requirements that apply to the project site. Indicate where in the Stormwater Site Plan the documentation showing how the minimum requirements are satisfied can be found. See Section 4.1.4 above.

### **Operation and Maintenance Manual**

Submit an operations and maintenance manual for each flow control and treatment facility. The manual should contain a description of the facility, what it does, and how it works. The manual must identify and describe the maintenance tasks, and the frequency of each task. The maintenance tasks and frequencies must meet the standards established in this manual.

Include a recommended format for a maintenance activity log that will indicate what actions will have been taken.

The manual must prominently indicate where it should be kept, and that it must be made available for inspection by the City.

### **Special Reports and Studies**

In the Appendices, include any special reports and studies conducted to prepare the Stormwater Site Plan (e.g. soil testing, wetlands delineation).

### **Submittal Requirements Checklist**

A copy of the checklist can be found in Appendix I-E and shall be completed by the engineer.

### **Bond Quantities Worksheet**

If the City requires a performance bond (or other financial guarantee) for proper construction and operation of construction site BMPs, and proper construction of permanent drainage facilities, the designer shall provide documentation to establish the appropriate bond amount. For an example see Appendix I-F.

### **Hydraulic Analysis Worksheet**

A copy of the worksheet can be found in Appendix I-G and shall be completed by the engineer.

#### **4.1.8 Step 8 – Check Compliance with All Applicable Minimum Requirements**

A Stormwater Site Plan as designed and implemented should specifically fulfill all Minimum Requirements applicable to the project. The Stormwater Site Plan should be reviewed to check that these requirements are satisfied.

### **4.2 Plans Required After Stormwater Site Plan Approval**

This section includes the specifications and contents required of those plans submitted after the City has approved the original Stormwater Site Plan.

#### **4.2.1 Stormwater Site Plan Changes**

If the designer wishes to make changes or revisions to the originally approved stormwater site plan, the proposed revisions shall be submitted to the City prior to construction. The submittals should include the following:

1. 3 sets of substitute pages of the originally approved Stormwater Site Plan that include the proposed changes.
2. 3 sets of Revised drawings showing any structural changes.
3. Any other supporting information that explains and supports the reason for the change.

#### **4.2.2 Final Corrected Plan Submittal**

If the project included construction of conveyance systems, treatment facilities, flow control facilities, or structural source control BMPs (i.e., this does not extend to construction of On-site Stormwater Management BMPs), the applicant shall submit a final corrected plan (“as-builts”) to the City when the project is completed. These should be engineering drawings that accurately represent the project as constructed. These corrected drawings must be professionally drafted revisions that are stamped, signed, and dated by a licensed civil engineer registered in the state of Washington.

# Chapter 5 - BMP and Facility Selection Process for Permanent Stormwater Control Plans

---

## 5.1 Purpose

The purpose of this chapter is to provide guidance for selecting permanent BMPs and facilities for new development and redevelopment sites (including retrofitting of redevelopment sites). The task of selecting BMPs and facilities is necessary to complete the Permanent Stormwater Control Plan - one of the major components of a Stormwater Site Plan. The details for how to complete the other major component - a Construction Stormwater Pollution Prevention Plan - are included in Chapter 3 of Volume II of this manual.

The City's pollution control strategy is to emphasize pollution prevention first, through the application of source control BMPs. Then the application of appropriate treatment and flow control facilities fulfills the statutory obligation to provide "all known available and reasonable methods by industries and others to prevent and control the pollution of the waters of the State of Washington." (RCW 90.48.010) This statutory requirement is generally known by an acronym – AKART.

The remainder of this Chapter presents seven steps in selecting BMPs, Treatment Facilities, and Flow Control Facilities.

## 5.2 BMP and Facility Selection Process

### 5.2.1 Step I - Determine and Read the Applicable Minimum Requirements

Section 3.5 establishes project size thresholds for the application of Minimum Requirements to new development and redevelopment projects. Figures 3.2 and 3.3 provide the same thresholds in a flow chart format.

### 5.2.2 Step II - Select Source Control BMPs

**Note: If your project is a residential development, you may skip this step.**

Refer to Volume IV. If the project involves construction of areas or facilities to conduct any of the activities described Volume IV, the "applicable" structural source control BMPs described in that section must be constructed as part of the project. In addition, if the specific business enterprise that will occupy the site is known, the "applicable" operational source control BMPs must also be described.

The project may have additional source control responsibilities as a result of area-specific pollution control plans (e.g., watershed or basin plans, water clean-up plans, groundwater management plans, lakes management plans), ordinances, and regulations. See Chapter 2 of this volume.

### **5.2.3 Step III - Determine Threshold Discharge Areas and Applicable Requirements for Treatment, Flow Control, and Wetlands Protection**

Minimum Requirements #6 (Runoff Treatment) and #7 (Flow Control) have size thresholds that determine their applicability (see Sections 3.5.6 and 3.5.7). Minimum Requirement #8 (wetlands protection) uses the same size thresholds as those used in #6 and #7. Those thresholds determine whether certain areas (called “threshold discharge areas”) of a project must use treatment and flow control facilities, designed by a professional engineer, or whether Minimum Requirement #5 (On-Site Stormwater Management BMPs) can be applied instead (see Section 3.5.5).

**Step 1: Read the definitions in Section 3.3** for the following terms: effective impervious surface, impervious surface, pollution-generating impervious surface (PGIS), pollution-generating pervious surface (PGPS), threshold discharge area.

**Step 2: Outline the threshold discharge areas** for your project site.

**Step 3: Determine the amount of effective pollution-generating impervious surfaces and pollution –generating pervious surfaces** in each threshold discharge area. Compare those totals to the categories in Section 3.5.6 (Table 3.1) to determine where treatment facilities are necessary. Note that On-site Stormwater Management BMPs are always applicable.

**Step 4: Determine the amount of effective impervious surfaces and converted pervious surfaces** in each threshold discharge area. Using an approved continuous runoff simulation model, estimate the increase in the 100-year flow frequency within each threshold discharge area.

Compare those totals to the categories in Section 3.5.7 (Table 3.2) to determine where flow control facilities are necessary. Note that On-site Stormwater Management BMPs may alter the calculation of effective impervious surface.

### **5.2.4 Step IV - Select Flow Control BMPs and Facilities**

Where appropriate apply the on-site stormwater management BMPs from chapter 5 of Volume V in accordance with Minimum Requirement #5. A determination should then be made whether Minimum Requirement # 7 – Flow Control OR Minimum Requirement #8 Wetland Protection apply to the project. Flow control facilities must be provided for discharges from those threshold discharge areas that exceeded the thresholds outlined in Table 3.2. Use an approved continuous runoff model (e.g. the Western Washington Hydrology Model) and the details in Chapter 3 of Volume III to size and design the facilities.

The following describes a selection process for those facilities.

**Step 1: Determine whether you can infiltrate.**

There are two possible options for infiltration, if pre-approval is granted by the City per Minimum Requirement #5.

The first option is to infiltrate through rapidly draining soils that do not meet the site characterization and site suitability criteria for providing adequate treatment. See Chapter 3 of Volume III for design criteria for infiltration facilities intended to provide flow control without treatment. In this case, a treatment facility must be provided prior to discharge to the ground for infiltration. The treatment facility would be located off-line with a capacity to treat the water quality design flow rate or volume (See Volume V, Chapter 4) to the applicable performance goal (See Volume V, Chapter 3). Volumes or flow rates in excess of the design volume or flow rate would bypass untreated into the infiltration basin. The infiltration facility must provide adequate volume such that the flow duration standard of Minimum Requirement #7, or the water surface elevation requirements of Minimum Requirement #8 will be achieved.

The second option is to infiltrate through soils that meet the site characterization and site suitability criteria in Chapter 7 of Volume V. The facility would be designed to meet the requirements for treatment and flow control. However, since such a facility would have to be located on-line it would be quite large in order to achieve the flow duration standard of Minimum Requirement #7. Therefore this option will, in most cases, be cost and space prohibitive.

**If infiltration facilities are appropriate for flow control and are planned for the entire site, then the flow control requirement has been met. Proceed to Step V. If infiltration facilities are not planned for the entire site, then proceed to Step 2.**

***Step 2: Use the Western Washington Hydrology Model or interim guidelines and a flow routing routine to size a detention facility.***

Refer to Chapter 2, of Volume III for an explanation of the use of the Western Washington Hydrology Model. Note that the more the site is left undisturbed, and the less impervious surfaces are created, the smaller the detention facility. Additional incentives are given within the model for reducing the disruption of the natural hydrology.

**5.2.5 Step V - Select Treatment Facilities**

**Note: This step-by-step process also appears in Volume V, Chapter 2.**

Please refer to Figure 5.1. Use the step-by-step process outlined below to determine the type of treatment facilities applicable to the project.

**Step 1: Determine the Receiving Waters and Pollutants of Concern Based on Off-Site Analysis.**

To obtain a more complete determination of the potential impacts of a stormwater discharge, the City requires an Offsite Analysis under the conditions described in Chapter 2 - Section 2.5 and Chapter 3 -Section 3.5.7, Volume I. Even without an offsite analysis requirement, the project proponent must determine the natural receiving waters for the stormwater drainage from the project site (ground water, wetland, lake, stream, salt water). This is necessary to determine the applicable treatment menu from which to select treatment facilities. If the discharge is to the City of Tacoma's municipal storm drainage system, the applicant must determine the drainage system receiving waters. Please see Chapter 2 of this volume.

The applicant should verify whether any type of water quality management plans, basin plans, water clean-up plan and/or local ordinances or regulations have established specific requirements for the receiving waters. Please see Chapter 2 of this volume. Examples of plans to be aware of include:

- **Watershed or Basin Plans:** These can be developed to cover a wide variety of geographic scales (e.g., Water Resource Inventory Areas, or sub-basins of a few square miles). They can be focused solely on establishing stormwater requirements (e.g., "Stormwater Basin Plans"), or can address a number of pollution and water quantity issues, including urban stormwater (e.g., Puget Sound Non-Point Action Plans).
- **Water Clean-up Plans:** These plans are written to establish a Total Maximum Daily Load (TMDL) of a pollutant or pollutants in a specific receiving water or basin, and to identify actions necessary to remain below that maximum loading. The plans may identify discharge limitations or management limitations (e.g., use of specific treatment facilities) for stormwater discharges from new and redevelopment projects.
- **Groundwater Management Plans (Wellhead Protection Plans):** To protect groundwater quality and/or quantity, these plans may identify actions required of stormwater discharges. Please see Chapter 2 of this volume.
- **Lake Management Plans:** These plans are developed to protect lakes from eutrophication due to inputs of phosphorus from the drainage basin. Control of phosphorus from new development is a likely requirement in any such plans.

An analysis of the proposed land use(s) of the project should also be used to determine the stormwater pollutants of concern. Table 5-1 lists the pollutants of concern from various land uses. Refer to this table for example treatment options after determining whether "basic," "enhanced," or "phosphorus" treatment requirements apply to the project. Those decisions are made in the steps below.

## **Step 2: Determine if an Oil Control Facility/Device is Required**

The use of oil control devices and facilities is dependent upon the specific land use proposed for development.

The Oil Control Menu (Volume V, Section 3.2) applies to projects that have “high-use sites.” High-use sites are those that typically generate high concentrations of oil due to high traffic turnover or the frequent transfer of oil. High-use sites include:

- An area of a commercial or industrial site subject to an expected average daily traffic (ADT) count equal to or greater than 100 vehicles per 1,000 square feet of gross building area;
- An area of a commercial or industrial site subject to petroleum storage and transfer in excess of 1,500 gallons per year, not including routinely delivered heating oil;
- An area of a commercial or industrial site subject to parking, storage or maintenance of 25 or more vehicles that are over 10 tons gross weight (trucks, buses, trains, heavy equipment, etc.);
- A road intersection with a measured ADT count of 25,000 vehicles or more on the main roadway and 15,000 vehicles or more on any intersecting roadway, excluding projects proposing primarily pedestrian or bicycle use improvements.

*Note: The traffic count can be estimated using information from “Trip Generation,” published by the Institute of Transportation Engineers, or from a traffic study prepared by a professional engineer or transportation specialist with experience in traffic estimation.*

Please refer to the Oil Control Menu for a listing of oil control facility options. Then see Chapter 11 of Volume V for guidance on the proper selection of options and design details.

*Note: Some land use types require the use of a spill control (SC-type) oil/water separator. Those situations are described in Volume IV and are separate from this oil control facility/device requirement.*

While a number of activities may be required to use spill control (SC-type) separators, only a few will necessitate American Petroleum Institute (API) or coalescing plate (CP)-type separators for treatment. The following urban land uses are likely to have areas that fall within the definition of “high-use sites” or have sufficient quantities of free oil present that can be treated by an API or CP-type oil/water separator.

- Industrial Machinery and Equipment, and Railroad Equipment Maintenance
- Log Storage and Sorting Yards
- Aircraft Maintenance Areas
- Railroad Yards
- Fueling Stations



- Facilities with drive-thru windows (e.g. espresso stands, fast food restaurants, banks...etc.)
- Vehicle Maintenance and Repair
- Construction Businesses (paving, heavy equipment storage and maintenance, storage of petroleum products)

If oil control is required for the site, please refer to the General Requirements in Chapter 4, Volume V. These requirements may affect the design and placement of facilities on the site (e.g., flow splitting).

***If an Oil Control Facility is required, select and apply an Oil Control Facility. Please refer to the Oil Control Menu in Volume V. After selecting an Oil Control Facility, proceed to Step 3.***

***If an Oil Control Facility is not required, proceed directly to Step 3.***

***Step 3: Determine if Control of Phosphorous is Required.***

Please refer to the plans, ordinances and regulations referred to in Step 1 as sources of information.

The requirement to provide phosphorous control is determined by the City, the Department of Ecology or the USEPA. The City will use the following sources of information for pursuing plans and implementing ordinances and/or regulations:

- Those waterbodies reported under section 305(b) of the Clean Water Act, and designated as not supporting beneficial uses due to phosphorous;
- Those listed in Washington State's Nonpoint Source Assessment required under section 319(a) of the Clean Water Act due to nutrients.

If phosphorus control is required, select and apply a phosphorus treatment facility. Please refer to the Phosphorus Treatment Menu in Volume V, Section 3.3. Select an option from the menu after reviewing the applicability and limitations, site suitability, and design criteria of each for compatibility with the site. You may also use Tables 5.1 through 5.3 in this chapter as an initial screening of options.

If you have selected a phosphorus treatment facility, please refer to the General Requirements in Chapter 4 of Volume V. They may affect the design and placement of the facility on the site.

*Note: Project sites subject to the Phosphorus Treatment requirement could also be subject to the Enhanced Treatment removal requirement (see Step 4). In that event, apply a facility or a treatment train that is listed in both the Enhanced Treatment Menu and the Phosphorus Treatment Menu.*

***If phosphorus treatment is not required for the site, proceed to Step 4.***

**Step 4: Determine if Enhanced Treatment is required.**

Enhanced treatment is required for:

Industrial project sites,  
Commercial project sites,  
Multi-family project sites, and  
Arterials and highways

that discharge to fish-bearing streams, lakes, or to waters or conveyance systems tributary to fish-bearing streams or lakes. For developments with a mix of land use types, the Enhanced Treatment requirement shall apply when the runoff from the areas subject to the Enhanced Treatment requirement comprise 50% or more of the total runoff within a threshold discharge area.

**If the project must apply Enhanced Treatment, select and apply an appropriate Enhanced Treatment facility.** Please refer to the Enhanced Treatment Menu in Volume V, Section 3.4. Select an option from the menu after reviewing the applicability and limitations, site suitability, and design criteria of each for compatibility with the site. You may also use Tables 5.1 through 5.3 in this chapter for an initial screening of options.

*Note: Project sites subject to the Enhanced Treatment requirement could also be subject to a phosphorus removal requirement if located in an area designated for phosphorus control. In that event, apply a facility or a treatment train that is listed in both the Enhanced Treatment Menu and the Phosphorus Treatment Menu.*

If you have selected an Enhanced Treatment facility, please refer to the General Requirements in Chapter 4 of Volume V. They may affect the design and placement of the facility on the site.

***Infiltration for Pollutant Removal as an enhanced treatment practice:***

Where appropriate, the applicant shall determine if infiltration for pollutant removal is practicable.

Please check the infiltration treatment design criteria in Chapter 7 of this Volume V. Infiltration can be effective at treating stormwater runoff, but soil properties must be appropriate to achieve effective treatment while not adversely impacting ground water resources. The location and depth to bedrock, the water table, or impermeable layers (such as glacial till), and the proximity to wells, foundations, septic tank drainfields, and unstable slopes can preclude the use of infiltration. Infiltration treatment facilities must be preceded by a pretreatment facility such as a presettling basin or vault, to reduce the occurrence of plugging. Any of the basic treatment facilities, and detention ponds designed to meet flow control requirements, can also be used for pre-treatment.

If treatment through infiltration is planned, please refer to the General Requirements in Chapter 4 of Volume V. They can affect the design and placement of facilities on your site. For non-residential developments, if

the infiltration site is within ¼ mile of a fish-bearing stream, a tributary to a fish-bearing stream, or a lake, please refer to the Enhanced Treatment Menu (Volume V, Section 3.4). Read the “Where Applied” paragraph in that section to determine if the Enhanced Treatment Menu applies to part of the site or the entire site. If it applies, read the “Note” under “Infiltration with appropriate pretreatment” to identify special pretreatment needs. If the infiltration site is within ¼ mile of phosphorus-sensitive receiving water, please refer to the Phosphorus Treatment Menu (Volume V, Section 3.3) for special pretreatment needs.

*Note: Infiltration through soils that do not meet the site suitability criteria in Chapter 7 of Volume V, for treatment, may still be appropriate for flow control (see Chapter 3 of Volume III). However, the infiltration must be preceded by at least a basic treatment facility.*

**If Enhanced Treatment is required for the site, and treatment through infiltration is practicable, select and apply pretreatment and an infiltration treatment facility. If treatment through infiltration is not practicable, use other Enhanced Treatment Practices.**

**If Enhanced Treatment does not apply to the site, please proceed to Step 5.**

***Step 5: Select a Basic Treatment Facility.***

Please refer to the Basic Treatment Menu in Volume V, Section 3.5. Select an option from the menu after reviewing the applicability and limitations, site suitability, and design criteria of each for compatibility with the site. You may also use Tables 5.1 through 5.3 in this chapter as an initial screening of options.

After selecting a Basic Treatment Facility, please refer to the General Requirements in Chapter 4 of Volume V. They may affect the design and placement of the facility on the site.

**Note: For guidance on additional factors that can affect treatment facility selection, please refer to Section 2.2 of Volume V.**

The Basic Treatment Menu is generally applied to:

- Residential projects not otherwise needing phosphorus control in Step 3 as designated by USEPA, the Department of Ecology, or the City; and
- Project sites discharging directly to salt waters, river segments, and lakes listed in Appendix I-C; and
- Project sites that drain to streams that are not fish-bearing, or to waters not tributary to fish-bearing streams;
- Landscaped areas of industrial, commercial, and multi-family project sites, and parking lots of industrial and commercial project sites, dedicated solely to parking of employees’ private vehicles, that do not involve any other pollution-generating sources (e.g., industrial activities, customer parking, storage of erodible or leachable material, wastes or chemicals).

- For developments with a mix of land use types, the Basic Treatment requirement shall apply when the runoff from the areas subject to the Basic Treatment requirement comprise 50% or more of the total runoff within a threshold discharge area.
- Project sites that discharge to the ground, UNLESS:
  - The soil suitability criteria for infiltration treatment are met (use infiltration treatment; see Chapter 7 of Volume V), or
  - The project uses infiltration strictly for flow control – not treatment - and the discharge is within ¼-mile of a phosphorus sensitive lake (use the Phosphorus Treatment Menu), or within ¼ mile of a fish-bearing stream, or a lake (use the Enhanced Treatment Menu).

**You have completed the treatment facility selection process.**

#### **5.2.6 Step VI - Review Selection of BMPs and Facilities**

The list of treatment and flow control facilities, and the list of source control BMPs should be reviewed. The site designer may want to re-evaluate site layout to reduce the need for construction of facilities, or the size of the facilities by reducing the amount of impervious surfaces created and increasing the areas to be left undisturbed.

#### **5.2.7 Step VII - Complete Development of Permanent Stormwater Control Plan**

The design and location of the BMPs and facilities on the site must be determined using the detailed guidance in Volumes III, IV, and V. Please refer to Chapter 4 for guidance on the contents of the Stormwater Site Plan which includes the Permanent Stormwater Control Plan and the Erosion and Sediment Control Plan.

**Table 5.1 Suggested Stormwater Treatment Options  
for New Development and Redevelopment Projects**

Pollutant Sources	Pollutants of Concern	Basic Treatment	Enhanced Treatment	Phosphorus Treatment
<b>ROOFS:</b>				
Com/Ind				
Metal	Zn	STW/INF	LSF/ASF/STW/INF	
Vents & Emissions	O & G, TSS, Organics	OWS/CBI + BF/WP/STW	OWS/CBI + INF/ASF/STW/LSF	OWS/CBI + INF/LWP/LSF
<b>PARKING LOT/DRIVEWAY:</b>				
>High-use Site	High O & G, TSS, Cu, Zn, PAH	OWS/CBI/LinSF + BF/WP/STW	OWS/CBI + BF/WP/WV + SF	OWS/CBI + LSF/LWP, or OWS/CBI + BF/WP/WV + SF
<High-use	O & G, TSS	BF/WP/STW	BF/WP/STW/WV + SF	LSF/LWP, or BF/WP/WV+SF
<b>STREETS/HIGHWAYS:</b>				
Arterials/H'ways	O & G, TSS, Cu, Zn, PAH	BF/WP/WV/STW	INF/LSF/ASF/STW, or BF/WV/WP + SF	INF/LSF/LWP, or BF/WV + SF
Residential Collectors	Low O & G, TSS, Cu, Zn	BF/WP/STW/INF	Not Applicable	INF/LSF/LWP, or BF/WV + SF
High Use Site Intersections	High O & G, TSS, Cu, Zn, PAH	OWS + BF/WP/WV/LinSF	OWS + BF/WV+SF, or OWS + LinSF+BF	OWS + ASF, or OWS + LinSF + Filter Strip
<b>OTHER SOURCES:</b>				
Industrial/Commercial Development	O & G, TSS, Cu, Zn	WP/WV/SF/STW	LSF/ASF/STW, or BF/WP/WV + SF	LSF/ASF/LWP, or BF/WP/STW + SF
Residential Development	TSS, Pest/Herbicides Nutrients	INF/BF/WP/SF/STW	Not Applicable	INF/LSF/LWP, or BF/WP/STW + SF
Large PGPS	TSS, Nutrients, Pest/Herbicides	WP/STW/SF	Not Applicable	LSF/LWP, or WP/STW + SF
Uncovered Fueling Stations:	High conc. O & G	OWS + BF/WP	OWS + LSF/ASF, or OWS+LinSF+Filter strip	OWS + LSF/ASF, or OWS+LinSF+ Filter strip
Industrial Yards	High O & G, TSS, Metals, PAH	OWS/CBI + BF/WP, or PSB/WV + OWS/CBI + BF/WP	OWS/CBI + LSF/ASF/STW, or OWS/CBI + BF/WP/WV + SF	OWS/CBI + LSF/ASF/LWP, or OWS/CBI + BF/WP/STW + SF
	Metals, TSS, PAH	BF/WP/STW, or PSB+BF/WP/STW	LSF/ASF/STW, or BF/WP/WV + SF	LSF/ASF/LWP, or BF/WP/STW + SF

**Notes:**

- 1 Though phosphorus is not typically listed as a pollutant of concern, it is present in most urban runoff situations. It becomes a pollutant of concern when identified by USEPA, the Department of Ecology, or a local government in a local management plan and when requirements are established in local ordinance or rules. If phosphorus is identified as a pollutant of concern, consider the treatment options listed here.
- 2 Application of effective source control measures per BMP S2.70 in Volume IV is the preferred approach for pollutant reduction. Where source control measures are not used, or where they are ineffective, stormwater treatment is necessary.

**Legend:**

/ = or : The slashes between the abbreviations for treatment types are intended to indicate equivalent treatment options  
 ASF = Amended Sand Filter  
 BF = Biofilter (includes swales and strips)  
 CBI = Catch Basin Insert, if applicable (see Chapter 12, Volume V)  
 Com/Ind = Commercial or industrial  
 Cu = Copper  
 INF = Infiltration  
 LinSF = Linear Sand Filter  
 LSF = Large Sand Filter  
 LWP = Large Wet Pond

O & G = Oil and Grease  
 OWS = Oil & Water Separator  
 PAH = Polycyclic Aromatic Hydrocarbons  
 PGPS = Pollution-generating pervious surface  
 PSB = Presettling Basin  
 SF = Sand Filter  
 STW = Stormwater Treatment Wetland  
 TSS = Total Suspended Solids  
 WP = Wet Pond  
 WV = Wetvault  
 Zn = Zinc

Additional Notes: - If a detention facility is needed for flow control to meet Min. Requirement #7 or #8, a combined detention and Wetpool (Basic or Large depending upon the discharge circumstance) facility should be considered.

	<b>TSS</b>	<b>Dissolved Metals</b>	<b>Soap</b>	<b>Total Phosphorus</b>	<b>Pesticides/ Fungicides</b>	<b>Hydro-carbons</b>
Wet Pond	*	+		+		+
Wet Vault	*					
Biofiltration	*	+			+	+
Sand Filter	*	+		+		+
Constructed Wetland	*	*	*		*	*
Compost Filters	+	+			*	*
Infiltration <sup>(2)</sup>	*				+	+
Oil/Water Separator						*

Notes:

\* Major Process

+ Minor Process

(1) Adapted from Kulzer; King Co.

(2) Assumes Loamy sand, Sandy loam, or Loam soils

(3) If neither a Major or Minor Process is shown, the Treatment Facility is not particularly effective at treating the identified pollutant

<b>Soil Type</b>	<b>Infiltration</b>	<b>Wet Pond*</b>	<b>Biofiltration* (Swale or Filter Strip)</b>
Coarse Sand or Cobbles	x	x	x
Sand	✓	x	x
Loamy Sand	✓	x	✓
Sandy Loam	✓	x	✓
Loam	x	x	✓
Silt Loam	x	x	✓
Sandy Clay Loam	x	✓	✓
Silty Clay Loam	x	✓	✓
Sandy Clay	x	✓	✓
Silty Clay	x	✓	x
Clay	x	✓	x

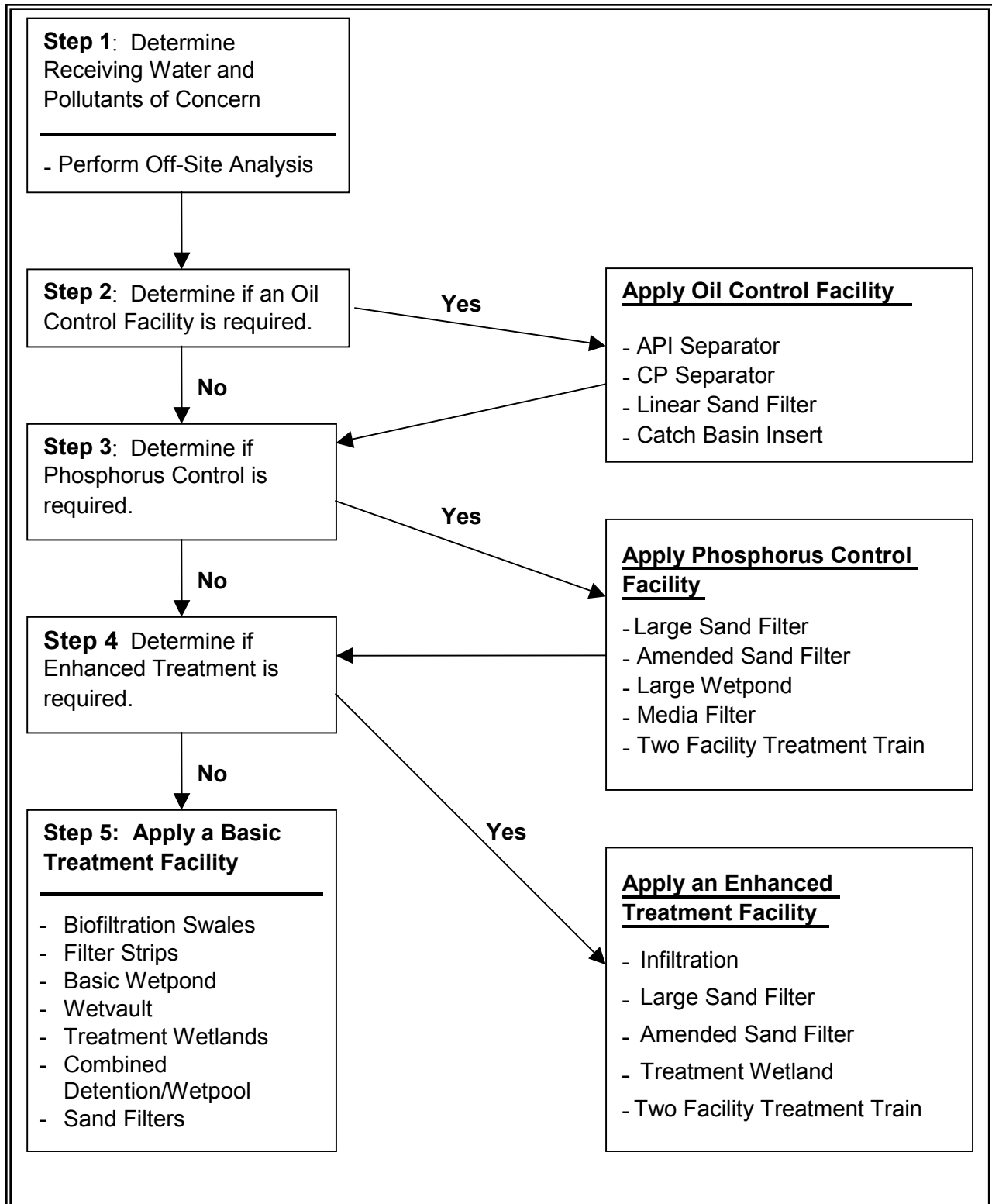
Notes: ✓ Indicates that use of the technology is generally appropriate for this soil type.

x Indicates that use of the technology is generally not appropriate for this soil type

\* Coarser soils may be used for these facilities if a liner is installed to prevent infiltration, or if the soils are amended to reduce the infiltration rate.

Note: Sand filtration is not listed because its feasibility is not dependent on soil type.

**Figure 5-1 Treatment Facility Selection Flow Chart**



# Appendix I-A

## Guidance for Altering the Minimum Requirements Through Basin Planning

---

### **Basin Planning Applied to Source Control (Minimum Requirement #3)**

Basin plans can identify potential sources of pollution and develop strategies to eliminate or control these sources to protect beneficial uses. A basin plan can include the following source control strategies:

1. Detection and correction of illicit discharges to storm sewer systems, including the use of dry weather sampling and dye-tracing techniques;
2. Identification of existing businesses, industries, utilities, and other activities that may store materials susceptible to spillage or leakage of pollutants into the storm sewer system or to the ground via wells, drains, or sumps;
3. Elimination or control of pollutant sources identified in (2);
4. Identification and control of future businesses, industries, utilities, and other activities which may store materials susceptible to spillage or leakage of pollutants into the storm sewer system; and
5. Training and public education.

### **Basin Planning Applied to Runoff Treatment (Minimum Requirement #6)**

Basin plans can develop different runoff treatment requirements and performance standards to reduce pollutant concentrations or loads based on an evaluation of the beneficial uses to be protected within or downstream of a watershed. Consideration must be given to the antidegradation provisions of the Clean Water Act and implementing state water quality standards. The evaluation should include an analysis of existing and future conditions. Basin specific requirements and performance standards can be developed based on an evaluation of pollutant loads and modeling of receiving water conditions.

The Basic Treatment Level is viewed as a minimum technology-based requirement that must be applied regardless of the quality of the receiving waters. Additional levels of control beyond the Basic Treatment Level of Minimum Requirement #6 may be justified in order to control the impacts of future development.

Runoff treatment requirements and performance standards developed from a basin plan should apply to individual development sites. Regional treatment facilities can be considered an acceptable substitute for on-site treatment facilities if they can meet the identified treatment requirements and performance standards. A limitation to the use of regional treatment systems is that the conveyances used to transport the stormwater to the facility must not include waters of the state that have existing or attainable beneficial uses other than drainage.

### **Basin Planning Applied to Flow Control (Minimum Requirement #7)**

Basin planning is well-suited to control stream channel erosion for both existing and future conditions. Flow control standards developed from a basin plan may include a combination of on-site, regional, and stream protection and rehabilitation measures. On-site standards are usually the primary mechanism to protect streams from the impacts of increased high flows in



future conditions. Regional flow control facilities are used primarily to correct existing stream erosion problems. Basin plans can evaluate retrofitting opportunities, such as modified outlets for existing stormwater detention facilities.

Stream protection and rehabilitation measures may be applied where stream channel erosion problems exist that will not be corrected by on-site or regional facilities. However, caution is urged in the application of such measures. If the causes of the stream channel erosion problems still exist, repairs to the physical expression of those problems may be short-lived. In some instances, it may be prudent to apply in-stream measures to reduce impacts until the basin hydrology is improved.

Another potential outcome of basin planning is the identification of a different flow control standard. Ecology's flow duration standard is based upon a generalization that the threshold of significant bedload movement in Western Washington streams occurs at 50% of the 2-year return stream flow. Through field observations and measurements, a local government may estimate a more appropriate threshold – higher or lower- for a specific stream. The alternative threshold can become the lower limit for the range of flows over which the duration standard applies. For instance, if the threshold is established at 70% of a 2-year return flow, the alternative standard would be to match the discharge durations of flows from the developed site to the range of pre-developed discharge rates from 70% of the 2-year peak flow up to the full 50-year peak flow.

### **Basin Planning Applied to Wetlands and other Sensitive Areas (Minimum Requirement #8)**

Basin planning can be used to develop alternative protection standards for wetlands and other sensitive areas, such as landslide hazard areas, wellhead protection areas, and ground water quality management areas. These standards can include source control, runoff treatment, flow control, stage levels, and frequency and duration of inundations.

# Appendix I-B

## Water Quality Treatment Design Storm, Volume, and Flow Rate

---

### Water Quality Design Storm

A 24-hour storm with a 6-month return frequency (a.k.a., 6-month, 24-hour storm). The 6-month, 24-hour storm can be estimated as 72% of the 2-year, 24-hour rainfall amount for areas in western Washington.

### Water Quality Design Storm Volume

The volume of runoff predicted from a 6-month, 24-hour storm.

Facilities such as wetpools are sized based upon the volume of runoff produced by the water quality design storm. They are the same size whether they precede, follow, or are incorporated (i.e., combined detention and wetpool facilities) into detention facilities for flow control. The water quality design storm volume can be computed using the SCS (NRCS) curve number equations in Volume III, Chapter 2.

Unless amended to reflect local precipitation statistics, the 6-month, 24-hour precipitation amount may be assumed to be 72 percent of the 2-year, 24-hour amount. Precipitation estimates of the 6-month and 2-year, 24-hour storms for certain towns and cities are listed in this appendix. For other areas, interpolating between isopluvials for the 2-year, 24-hour precipitation and multiplying by 72% yields the appropriate storm size. Isopluvials for 2-year, 24-hour amounts for Western Washington are reprinted in Volume III.

### Background for the Water Quality Design Storm and Volume:

The 6-month, 24-hour storm was the water quality design storm in the 1992 Stormwater Management Manual for the Puget Sound Basin. It was originally chosen when developing the Puget Sound manual based upon a judgement of when the incremental costs of additional treatment capacity exceed the incremental benefits. In particular, the cost of providing the increased detention volume for a wet pond was not seen as cost-effective when compared with the incremental amount of annual stormwater volume that would be effectively treated. Rainfall data from Sea-Tac was used in the original analysis.

*Estimation of the 6-month, 24-hour rainfall amount for rain gauge sites:* There are at least two ways to estimate the rainfall amount of a 6-month, 24-hour storm. One way is to analyze the 24-hour rainfall records for each rainfall station. The more extensive the record is, the more confidence there is in the estimate. The rainfall amount which has a probability of being equaled or exceeded twice a year is the 6-month, 24-hour storm.

The 6-month, 24-hour rainfall amounts shown for 58 stations in Table B.1 have been estimated by analyzing the daily rain gauge data obtained from CD-ROM Hydrodata, USGS Daily and Peak Values, published by Hydrosphere Data Products, Inc. <sup>(11)</sup>

The way in which the 6-month, 24-hour estimates in Table B.2 are calculated is as follows. A data set containing the annual maxima series for 24-hour durations for rainfall stations throughout the state was used to determine the 2-year, 24-hour return frequency in the first column of Table B.2. The data set was collected by Dr. Schaefer of the Washington State Department of Ecology and is more fully described in "Regional Analyses of Precipitation Annual Maxima in Washington State"<sup>(12)</sup>. An algorithm was applied to convert the series to a partial duration series. Dr. Schaefer describes the conversion as follows: "A return period of 1.16 years (annual exceedance probability of 0.862) in the annual maxima data series is equivalent to a 6-month return period in the partial duration data series. The 6-month values were computed using at-site 24-hour station mean values, regional coefficients of variation (Cv) and L-skewness (tau3), and a frequency factor (K) of -0.94 which corresponds to a return period of 1.16 years. This K value of -0.94 yields 6-month estimates that are correct within 3% +/- for various Kappa distribution parameter sets for climates from arid to rainforest in Washington State." (The reader is referred to Volume I References #13 and #14.) Note that the 2-year storm values in Table B.2 differ slightly from those in Table B.1 because they are a different data set and have undergone additional statistical analysis. Where a single site is listed in both tables, the value listed in Table B.2 should be used.

*Estimation of 6-month, 24-hour amounts for any project site:*

A disadvantage to using the 6-month, 24-hour storm as the design storm is that all isopluvials identifying 6-month, 24-hour storms statewide do not exist. A map would need to be produced, or a method developed to estimate the volume for projects at sites not listed in a reference table of 6-month, 24-hour storms. One method to do the latter is described below.

The first step is to look for a consistent relationship between the 6-month, 24-hour rainfall amount and a rainfall amount for which we have isopluvials. Based upon an analysis of the rainfall record of 58 stations across the state, the 6-month, and 2-year, 24-hour rainfall amounts were calculated and compared. Those results are shown in Table B.1. The arithmetic average of the ratio of the 6-month to the 2-year totals for 35 stations in western Washington (expressed as a percentage) was 71%. The median was 72%. With the exception of a few stations, the percentages vary within a range of 67% to 76%.

Updated statewide isopluvial maps for the 2-year, 24-hour rainfall amounts are expected to be available soon. By interpolation, the 2-year rainfall amount for a project site can be easily identified. Multiplying the 2-year amount by 72% yields an estimate of the 6-month, 24-hour rainfall amount.

*Justification for use of the 6-month, 24-hour storm:*

In the manual update, it is consistently proposed to retain the 6-month, 24-hour storm (hereafter referred to as the 6/24 storm) as the "Water Quality Design Storm." The 1992 manual noted that 24-hour storms up through the 6/24 storm produced 91% of the historic runoff volume (Sea-Tac Airport rain data). That is probably an overestimate because many smaller storms do not produce measurable runoff and the statement ignores the fact of variability in soil absorption capacity preceding each event. However, it is the presumption made in 1992, and it is not fatally incorrect.

The original basis for the 6-month, 24-hour rainfall amount was a cost-effectiveness analysis referred to in Appendix AI-2.1 of the '92 manual. The assumption in these comparisons is that storm sizes crudely track relative runoff quantities. The cost analysis simply compared the incremental cost increase in wet ponds sized to treat the 91<sup>st</sup> percentile storm versus the 95<sup>th</sup> percentile storm. For a 4% increase in annual treated volume, the pond had to be increased by 34% in volume. That was seen as being not cost-effective and therefore not cost reasonable. (The costs to treat the runoff from the 91<sup>st</sup> percentile storm were further supported by an analysis for three example developments (Herrera, 1993)).

The percentage of the 24-hour rainfall volumes that the 6-month, 24-hour storm and smaller 24-hour rainfall amounts represent changes across the state. For the 34 western Washington stations computed, the 6-month storm and smaller storms represent from 88.4% to 93.4% of the total rainfall volume. See Table B.1, column entitled, "6 month, % Rainfall Volume." Therefore, the cost-effectiveness analysis is not exactly the same for other areas. However, because the 91% value for Sea-Tac is a mid-range figure for a data set with small variation, the cost analysis is a reasonable basis for setting the 6-month, 24-hour storm as the water quality design storm.

Citing a particular percentage of the 2-year, 24-hour rainfall amount (or a 6-month, 24-hour event) means that different areas of the state will be effectively sizing treatment facilities for the runoff from storms of different sizes. However, those size differences are based upon actual differences in rainfall amounts among the sites.

## **Water Quality Design Flow Rate**

*Preceding detention facilities or when detention facilities are not required:* The flow rate at or below which 91% of the runoff volume, as estimated by an approved continuous runoff model, will be treated. Design criteria for treatment facilities are assigned to achieve the applicable performance goal at the water quality design flow rate (e.g., 80% TSS removal).

*Downstream of detention facilities:* The full 2-year release rate from the detention facility.

### **Background for the Water Quality Design Flow Rate:**

*Basis for Water Quality Design Flow Rate in 1992 Manual:*

The cost effectiveness analysis performed for the 1992 manual seems to assumed that BMPs sized by flow rate (bioswales, filter strips, oil/water separators), using the 10-minute peak flow predicted by SBUH for a 6/24 storm, and a Type 1A storm distribution would result in treating roughly 91 percent of the annual runoff volume. That appears to be an incorrect assumption. The error is caused by the size of the 10-minute peak increment of the 6/24 storm when compared to the actual rainfall intensities experienced in western Washington. The Olympia, Lacey, Tumwater, Thurston Co. stormwater managers provided some actual 2-hour rainfall intensity statistics for Olympia, and compared these to the intensity predicted by a 6/24, type 1A storm for Olympia. The statistics seem to confirm the conservativeness of the original assumption.

*Basis for a new Water Quality Design Flow Rate:*

The use of continuous runoff modeling techniques provides another perspective on flow rates. Continuous runoff modeling takes a long, uninterrupted record of observed rainfall data and transforms it into a record (a.k.a., time series) of runoff data. This is done by use of a set of mathematical algorithms that represent the rainfall-runoff processes. The model's algorithms

are adjusted to simulate the rainfall/runoff relationships of a particular watershed. HSPF, Hydrological Simulation Program – Fortran, is one type of continuous runoff model. The Department of Ecology has funded the development of an HSPF-based continuous runoff model for Western Washington using the best available precipitation and mathematical algorithms. It is referred to as the Western Washington Hydrology Model (WWHM). King County has already employed an HSPF-based model (King County Runoff Time Series, KCRTS) to estimate runoff flow rates and volumes in their jurisdiction.

Runoff flow rates for a number of different development scenarios have been estimated and compared using KCRTS and the Santa Barbara Urban Hydrograph Method (SBUH). KCRTS was used for this comparison because it provides flow rates in 15-minute time increments. The WWHM only provides 1-hour increments. A 15-minute increment data set is more comparable to the 10-minute time step of the SBUH analysis. It is expected that a comparison between the WWHM and SBUH would provide similar results as the KCRTS vs. SBUH comparison.

A spreadsheet can be used to statistically analyze the long time series of runoff predicted by KCRTS. That analysis shows that only 2.5 to 3% of the annual runoff volume is discharged at a rate that equals or exceeds the peak 10 minute runoff predicted by SBUH for the water quality design storm. This is a second indicator that the 1992 manual water quality design flow rate is too conservative if the intent is to provide effective treatment for 91% of the runoff volume.

Using the same spreadsheet, a flow rate can be identified above which only 9% of the annual runoff volume is discharged. However, that flow rate is still too conservative if the intent is to provide effective treatment for 91% of the annual runoff volume. An off-line facility that is designed to receive and effectively treat a flow rate at or below which 91% of the annual volume is discharged, will actually treat 97 to 98% of the annual runoff volume. This occurs because a flow splitter continues to send a portion (in this instance, the flow rate above which only 9% of the runoff volume is discharged) of the higher flow rates to the treatment facility. To treat 91% of the annual runoff volume, a flow splitter should start to bypass incremental portions of flow rates above a rate at which 72 to 80% of the runoff volume is discharged. The above percentage changes with project characteristics, most notably the percent imperviousness of a project.

This flow rate, which a flow splitter must route to the treatment facility in an off-line mode, becomes the water quality design flow rate. This rate is sometimes referred to as the 91% flow rate in the manual. At the time of publication of the manual, the WWHM did not identify this water quality design flow rate directly for the user. The user would have to take the output of the WWHM and perform a statistical analysis of the data set to determine the flow rate associated with treating 91% of the runoff volume. However, the WWHM only provides flow rates in 1-hour time increments. Further, it is more appropriate to use 15-minute time increments for facilities that perform their treatment function with short hydraulic residence times. Therefore, that flow rate would have to be increased by a factor to convert the hourly flow rate to an equivalent 15-minute flow rate.

#### *Determination of the Water Quality Design Flow Rate for a project:*

Rather than leaving these calculations to the user of the manual, it is Ecology's intent to have the WWHM amended to provide the water quality design flow rate directly to the user. Until such time as the WWHM does that, a method to estimate the water quality design flow rate has been provided. That method is to multiply the 2-year return frequency flow rate, identified by the WWHM, for the post-development condition by a factor that varies with the percent effective

impervious surface of the project. A table containing the scale factors is included in Chapter 4 of Volume V. The factor also includes an adjustment intended to convert the hourly flow rates to 15-minute flow rates.

#### *Water Quality Design Flow Rate Downstream of Detention Facilities:*

The 91% flow rate downstream of detention will be significantly smaller than upstream of detention. The detention facilities, which are fitted with flow-restricting orifices, significantly change the distribution of flow rates. The flow duration standard requires that the total amount of time that flows are discharged above  $\frac{1}{2}$  of the 2-year flow not increase. There is a much greater volume of surface runoff post-development than pre-development. Therefore, an extra volume of water must be discharged at rates below  $\frac{1}{2}$  the 2-year rate for extended periods of time.

The result of this redistribution is that downstream treatment facilities will operate for extended periods of time at flow rates at or near their design flow rate. For downstream facilities sized for the 91% flow rate this will achieve less annual treatment removal efficiency than that achieved by facilities located upstream. Upstream treatment facilities see more variable flow rates, and presumably, operate more efficiently at lower flow rates than the design flow rate. In addition, downstream detention facilities would have a hard time meeting the annual TSS removal performance goal of 80% removal.

In order to compensate for this, the water quality design flow rate, downstream of detention facilities is the 2-year return frequency flow from a detention facility that is designed to meet the flow duration standard. The 2-year frequency flow rate represents a flow rate that will effectively treat a greater percentage of the annual runoff volume than 91%. It still represents a significant – on the order of 3 times – facility size reduction compared to a facility located upstream.

This requirement applies to treatment facilities that are sized based upon a short hydraulic residence time or velocity. This would include biofiltration swales, oil/water separators, and sand/media filters that are not preceded by a significant storage reservoir (i.e., above the filtration unit). Where a sand/media filter is preceded by a significant equalization/storage reservoir, it may be sized using a continuous runoff model and a volume-based approach to achieve the 91% or 95% volume targets (whichever is applicable).

#### *Impact on Design Criteria:*

The 1992 design criteria for some public domain treatment facilities had been intended to apply to the water quality design flow rate in the 1992 manual. The new water quality design flow rate is a fraction of that old rate. If the 1992 design criteria were retained and applied at the new water quality design flow rate, new treatment facilities would be that same fraction of the size of existing treatment facilities. This would not be a prudent action since it is not known whether existing treatment facilities can meet the proposed performance goals. Until more reliable monitoring information to judge the performance of existing treatment facilities exist, the prudent action is to adjust their design criteria such that they continue to be built to approximately the same size as they should have been built using the 1992 design criteria and design flow rates. This has been done for swales, strips, and oil/water separators. The design criteria adjustments are summarized below, and should appear in the chapter for each type of facility in Volume V.

Treatment Type	1992 Criteria	2001 Criteria
Basic & Wet Biofiltration Swale	9 minutes	22 minutes
Continuous Inflow Biofiltration Swale	N/A	44 minutes
Filter Strips	9 minutes	22 minutes
Oil/Water Separators	Q = 1992 flow rate	Q = 2.15x new water quality design flow rate

Table B.1 24-Hour Rainfall Amounts and Comparisons for Selected USGS Stations								
	Station Name	6 Month Storm Inches	6 Month % Rainfall Volume	2 Year Storm Inches	6 Month/ 2 year %	90% Rainfall Inches	95% Rainfall Inches	Mean Annual Precip. Inches
1	Aberdeen	2.47	92.58%	3.43	72.0%	2.25	2.81	83.12
2	Anacortes	0.93	90.45%	1.37	67.9%	0.91	1.22	25.92
3	Appleton	1.39	89.04%	1.96	70.9%	1.45	1.80	32.71
4	Arlington	1.28	93.42%	1.74	73.6%	1.11	1.40	46.46
5	Bellingham	1.27	90.78%	1.79	70.9%	1.23	1.63	35.82
6	Bremerton	1.87	90.75%	2.61	71.6%	1.83	2.22	49.97
7	Cathlamet	2.13	92.52%	3.47	61.4%	1.89	2.59	78.97
8	Centralia	1.49	91.81%	2.09	71.3%	1.40	1.78	45.94
9	Chelan	0.62	84.50%	0.96	64.6%	0.76	1.00	10.44
10	Chimacum	1.20	89.63%	1.73	69.4%	1.22	1.52	29.45
11	Clearwater	3.46	92.88%	4.75	72.8%	3.04	3.94	125.25
12	CleElum	1.06	86.85%	1.66	63.9%	1.20	1.64	22.17
13	Colfax	0.80	90.52%	1.07	74.8%	0.80	0.99	19.78
14	Colville	0.71	90.46%	0.97	73.2%	0.69	0.86	18.31
15	Cushman Dam	3.31	91.26%	5.29	62.6%	3.18	4.25	100.82
16	Cushman PwrH	3.17	90.81%	4.42	71.7%	3.08	4.00	85.71
17	Darrington	2.90	91.19%	4.01	72.3%	2.73	3.42	82.90
18	Ellensburg	0.50	84.63%	0.79	63.3%	0.62	0.81	8.75
19	Elwha RS	2.14	90.49%	2.80	76.4%	2.11	2.53	55.87
20	Everett	1.10	93.14%	1.46	75.3%	1.00	1.22	36.80
21	Forks	3.47	92.50%	5.07	68.4%	3.13	4.00	117.83
22	Goldendale	0.84	86.92%	1.29	65.1%	0.98	1.25	17.57
23	Hartline	0.61	84.85%	0.96	63.5%	0.77	0.97	10.67
24	Kennewick	0.46	84.10%	0.71	64.8%	0.55	0.72	7.57
25	Lk. Wenatchee	2.20	85.87%	3.16	69.6%	2.58	3.16	42.72
26	Long Beach	2.32	93.09%	3.08	75.3%	2.04	2.55	80.89
27	Longview	1.41	92.02%	1.97	71.6%	1.29	1.67	45.62
28	Mc Millin	1.31	92.24%	1.82	72.0%	1.21	1.49	40.66
29	Monroe	1.38	92.90%	1.86	74.2%	1.26	1.53	48.16
30	Moses Lake	0.47	85.32%	0.70	67.1%	0.54	0.68	7.89
31	Oakville	1.81	92.86%	2.28	79.4%	1.62	1.98	57.35
32	Odessa	0.52	87.23%	0.76	68.4%	0.56	0.72	10.09
33	Olga	1.02	90.82%	1.52	67.1%	0.99	1.30	28.96
34	Olympia	1.74	91.13%	2.51	69.3%	1.65	2.19	50.68
35	Omak	0.66	85.89%	0.98	67.3%	0.79	0.98	11.97
36	Packwood	2.41	88.70%	3.52	68.5%	2.51	3.20	55.20



<b>Table B.1 24-Hour Rainfall Amounts and Comparisons for Selected USGS Stations</b>								
	<b>Station Name</b>	<b>6 Month Storm Inches</b>	<b>6 Month % Rainfall Volume</b>	<b>2 Year Storm Inches</b>	<b>6 Month/ 2 year %</b>	<b>90% Rainfall Inches</b>	<b>95% Rainfall Inches</b>	<b>Mean Annual Precip. Inches</b>
37	Pomeroy	0.75	89.29%	1.02	73.5%	0.78	0.98	16.04
38	Port Angeles	1.12	88.39%	1.66	67.5%	1.19	1.56	25.46
39	Port Townsend	0.77	90.56%	1.14	67.5%	0.76	0.95	19.13
40	Prosser	0.48	83.82%	0.74	64.9%	0.61	0.78	7.90
41	Quilcene	2.53	88.81%	3.40	74.4%	2.61	3.15	54.88
42	Quincy	0.53	82.12%	0.81	65.4%	0.68	0.90	8.07
43	Sea-Tac	1.32	91.13%	1.83	72.1%	1.27	1.63	38.10
44	Seattle JP	1.30	92.05%	1.74	74.7%	1.20	1.49	38.60
45	Sedro Woolley	1.50	92.07%	2.01	74.6%	1.41	1.80	46.97
46	Shelton	2.15	91.49%	3.13	68.7%	2.05	2.55	64.63
47	Smyrna	0.52	83.16%	0.76	68.4%	0.63	0.75	7.96
48	Spokane	0.68	89.54%	0.96	70.8%	0.70	0.88	16.04
49	Sunnyside	0.45	82.22%	0.73	61.6%	0.63	0.76	6.80
50	Tacoma	1.21	92.18%	1.61	75.2%	1.12	1.37	36.92
51	Toledo	1.36	92.73%	2.10	64.8%	1.25	1.68	50.18
52	Vancouver	1.35	91.32%	1.93	69.9%	1.28	1.62	38.87
53	Walla Walla	0.90	88.60%	1.23	73.2%	0.94	1.18	19.50
54	Waterville	0.67	84.43%	1.04	64.4%	0.81	1.05	11.47
55	Wauna	1.82	91.37%	2.50	72.8%	1.72	2.18	51.61
56	Wenatchee	0.58	81.97%	0.92	63.0%	0.80	1.04	8.93
57	Winthrop	0.75	85.36%	1.13	66.4%	0.94	1.13	14.28
58	Yakima	0.53	81.44%	0.85	62.4%	0.72	1.03	8.16

<b>Table B.2 24-Hour Rainfall Amounts and Statistics</b>					
<b>Station Name</b>	<b>Return 2-yr.</b>	<b>Freq 6-month</b>	<b>Knee-of-curve 24 hr. (in)</b>	<b>Mean Annual Storm (in)</b>	<b>Mean Annual Precip (in)</b>
Aberdeen	3.32	2.53	2.81		83.1
Anacortes	1.33	0.99	1.20		25.9
Appleton	1.97	1.47	1.80		32.7
Arlington	1.79	1.35	1.40		46.5
Auburn	2.00	1.51		0.54	44.9
Battle Ground	2.12	1.60			52.0
Bellingham 3SSW -- F	1.70	1.27			35.0
Bellingham CAA AP	1.56	1.17	1.63		35.8
Benton City 2NW	0.79	0.53			8.0
Blaine 1ENE	1.89	1.42		0.46	39.9
Bremerton	2.31	1.74	2.22		50.0
Buckley 1NE	2.09	1.58			49.0
Burlington	1.75	1.31		0.40	35.0
Carnation 4NW	1.91	1.44		0.49	47.5
Cathlamet 6NE	3.84	2.93	2.59		79.0
Centralia 1W	2.10	1.59	1.78	0.44	47.6
Chelan	0.94	0.65	1.00		10.4
Colfax 1NW	1.18	0.86	0.99		19.8
Colville	1.02	0.74	0.86		18.3
Colville WB AP	1.01	0.73		0.35	17.4
Coupville 1S	1.08	0.79			21.0
Cushman Dam	4.61	3.52	4.25	1.23	99.7
Darrington RS	3.32	2.53	3.42	0.84	79.8
Duvall 3NE	1.99	1.50			50.0
Ellensburg	0.70	0.48	0.80	0.25	9.2
Ellensburg WB AP	0.72	0.51			12.0
Elwha RS	2.74	2.07	2.53		55.9
Everett Jr. Col.	1.48	1.11	1.22	0.41	34.4
Forks 1E	4.90	3.76	3.99		117.8
Goldendale	1.12	0.81	1.25		17.6
Goldendale 2E	1.31	0.95			18.0
Hartline	0.89	0.62	0.98		10.7
Hoquiam AP	2.85	2.17			71.0
Kennewick	0.71	0.48	0.71		7.6
Kent	1.87	1.40			36.0

<b>Table B.2 24-Hour Rainfall Amounts and Statistics</b>					
<b>Station Name</b>	<b>Return 2-yr.</b>	<b>Freq 6-month</b>	<b>Knee-of-curve 24 hr. (in)</b>	<b>Mean Annual Storm (in)</b>	<b>Mean Annual Precip (in)</b>
Leavenworth	1.64	1.21			26.0
Long Beach Exp	2.99	2.28	2.54		80.0
Longview	2.20	1.66	1.67	0.48	48.1
Mazama 2W	1.59	1.17		0.41	22.7
Mc Millin Reservoir	1.81	1.36	1.49	0.46	40.0
Mill Creek	2.04	1.53			35.0
Monroe	1.91	1.44	1.52		48.2
Montesano 3NW	3.30	2.52		0.81	81.5
Moses Lake Devil Far	0.74	0.50	0.68		7.9
Mount Vernon 3WNW	1.60	1.20			32.0
Newport	1.41	1.05			29.0
Oakville	2.46	1.86	1.99		57.4
Odessa	0.80	0.55	0.72		10.1
Okanogan	0.90	0.63			12.0
Olga 2se	1.52	1.13	1.29		29.0
Olympia WB AP	2.62	1.98	2.18	0.62	51.1
Omak 2nw	0.99	0.70	0.98		12.0
Othello 5e	0.70	0.47			8.0
Packwood	2.92	2.21	3.16		55.2
Pomeroy	1.10	0.79	0.97		16.0
Port Angeles	1.69	1.26	1.56	0.42	24.2
Port Townsend	1.11	0.81	0.95	0.35	17.6
Prosser	0.74	0.49	0.78		7.9
Prosser 4NE	0.72	0.48			8.0
Pullman 2NW	1.17	0.86		0.41	22.3
Puyallup 2w Exp Stn	1.85	1.40			41.0
Quilcene 2SW	3.42	2.59	3.14		54.9
Quilcene Dam 5SW	3.84	2.92		0.77	69.4
Quincy 1S	0.77	0.52	0.90		8.1
Republic	1.04	0.76			17.0
Seattle Jackson Park	1.49	1.12	1.49		38.6
Seattle Tac WB AP	1.90	1.42	1.62	0.49	37.4
Seattle U. of W.	1.72	1.29			36.0
Sedro Woolley 1E	2.05	1.55	1.80		47.0
Sequim	1.11	0.80			16.0
Shelton	3.15	2.39	2.54		64.6

<b>Table B.2 24-Hour Rainfall Amounts and Statistics</b>					
<b>Station Name</b>	<b>Return 2-yr.</b>	<b>Freq 6-month</b>	<b>Knee-of-curve 24 hr. (in)</b>	<b>Mean Annual Storm (in)</b>	<b>Mean Annual Precip (in)</b>
Smyrna	0.79	0.53	0.75		8.0
Spokane	1.11	0.80	0.88		16.0
Spokane WB AP	0.97	0.70		0.35	17.0
Sunnyside	0.76	0.50	0.76	0.30	7.4
Tacoma City Hall	1.70	1.28	1.37		36.9
Toledo	1.99	1.51	1.68		50.2
Vancouver 4NNE	2.01	1.51	1.62		38.9
Walla Walla CAA AP	1.19	0.87	1.17		19.5
Waterville	1.00	0.70	1.05		11.5
Wauna	2.15	1.63	2.18		51.6
Wenatchee	0.95	0.65	1.04		8.9
Winthrop 1WSW	1.19	0.85	1.13		14.3
Yakima WB AP	0.81	0.54	1.03	0.33	8.2

# Appendix I-C

## Basic Treatment Receiving Waters

---

### 1. All Salt Waterbodies

### 2. Rivers

### Basic Treatment Applies Below This Location

Baker	Anderson Creek
Bogachiel	Bear Creek
Cascade	Marblemount
Chehalis	Bunker Creek
Clearwater	Town of Clearwater
Columbia	Canadian Border
Cowlitz	Skate Creek
Elwha	Lake Mills
Green	Howard Hanson Dam
Hoh	South Fork Hoh River
Humptulips	West and East Fork Confluence
Kalama	Italian Creek
Lewis	Swift Reservoir
Muddy	Clear Creek
Nisqually	Alder Lake
Nooksack	Glacier Creek
South Fork Nooksack	Hutchinson Creek
North River	Raymond
Puyallup	Carbon River
Queets	Clearwater River
Quillayute	Bogachiel River
Quinault	Lake Quinault
Sauk	Clear Creek
Satsop	Middle and East Fork Confluence
Skagit	Cascade River
Skokomish	Vance Creek
Skykomish	Beckler River
Snohomish	Snoqualmie River
Snoqualmie	Middle and North Fork Confluence
Sol Duc	Beaver Creek
Stillaguamish	North and South Fork Confluence
North Fork Stillaguamish	Boulder River
South Fork Stillaguamish	Canyon Creek
Suiattle	Darrington
Tilton	Bear Canyon Creek
Toutle	North and South Fork Confluence
North Fork Toutle	Green River
Washougal	Washougal
White	Greenwater River
Wind	Carson
Wynoochee	Wishkah River Road Bridge

### 3. Lakes

### County

Washington	King
Sammamish	King
Union	King
Whatcom	Whatcom
Silver	Cowlitz

Note: Local governments may petition for the addition of more waters to this list. The initial criteria for this list are rivers whose mean annual flow exceeds 1,000 cfs, and lakes whose surface area exceeds 300 acres. Additional waters do not have to meet these criteria, but should have sufficient background dilution capacity to accommodate dissolved metals additions from build-out conditions in the watershed under the latest Comprehensive Land Use Plan and zoning regulations.

# Appendix I-D

## Wetlands and Stormwater Management Guidelines

---

*As Amended from Chapter 14 of "Wetlands and Urbanization, Implications for the Future," by Richard R. Horner, Amanda A. Azous, Klaus O. Richter, Sarah S. Cooke, Lorin E. Reinelt and Kern Ewing*

If you are unfamiliar with these guidelines, read the description of the approach and organization that follows. If you are familiar, proceed directly to the appropriate guide sheet(s) for guidelines covering your issue(s) or objective(s):

Guide Sheet 1: Comprehensive Landscape Planning for Wetlands and Stormwater Management -- Page D-4

Guide Sheet 2: Wetlands Protection Guidelines -- Page D-12

### Approach and Organization of the Management Guidelines

#### Introduction

The Puget Sound Wetlands and Stormwater Management Research Program performed comprehensive research with the goal of deriving strategies that protect wetland resources in urban and urbanizing areas, while also benefiting the management of urban stormwater runoff that can affect those resources. The research primarily involved long-term comparisons of wetland ecosystem characteristics before and after their watersheds urbanized, and between a set of wetlands that became affected by urbanization (treatment sites) and a set whose watersheds did not change (control sites). This work was supplemented by shorter term and more intensive studies of pollutant transport and fate in wetlands, several laboratory experiments, and ongoing review of relevant work being performed elsewhere. These research efforts were aimed at defining the types of impacts that urbanization can cause and the degree to which they develop under different conditions, in order to identify means of avoiding or minimizing impacts that impair wetland structure and functioning. The program's scope embraced both situations where urban drainage incidentally affects wetlands in its path, as well as those in which direct stormwater management actions change wetlands' hydrology, water quality or both.

This document presents preliminary management guidelines for urban wetlands and their stormwater discharges based on the research results. The set of guidelines is the principal vehicle to implement the research findings in environmental planning and management practice.

**Guidelines Scope and Underlying Principles.** Note: For terms in **boldface** type see item 1 under Support Materials below.

1. These provisions currently have the status of guidelines rather than requirements. Application of these guidelines does not fulfill assessment and permitting requirements that may be associated with a project. It is, in general, necessary to follow the stipulations of the State Environmental Policy Act and to contact such agencies as the local planning agency; the Washington Departments of Ecology, Fisheries, and Wildlife; the U. S. Environmental Protection Agency; and the U. S. Army Corps of Engineers.

2. Using the guidelines should be approached from a problem-solving viewpoint. The “problem” is regarded to be accomplishing one or more particular planning or management objectives involving a **wetland** potentially or presently affected by stormwater drainage from an urban or urbanizing area. The objectives can be broad, specific, or both. Broad objectives involve comprehensive planning and subsequent management of a drainage catchment or other **landscape unit** containing one or more wetlands. Specific objectives pertain to managing a wetland having particular attributes to be sustained. Of course, the prospect for success is greater with ability to manage the whole landscape influencing the wetland, rather than just the wetland itself.
3. The guidelines are framed from the standpoint that some change in the landscape has the potential to modify the physical and chemical **structure** of the wetland environment, which in turn could alter biological communities and the wetland’s ecological **functions**. The general objective in this framework would be to avoid or minimize negative ecological change. This view is in contrast to one in which a wetland has at some time in the past experienced negative change, and consequent ecological degradation, and where the general objective would be to recover some or all of the lost structure and functioning through **enhancement** or **restoration** actions. Direct attention to this problem was outside the scope of the Puget Sound Wetlands and Stormwater Management Research Program. However, the guidelines do give information that applies to enhancement and restoration. For example, attempted restoration of a diverse amphibian community would not be successful if the water level fluctuation limits consistent with high amphibian species richness are not observed.
4. The guidelines can be applied with whatever information concerning the problem is available. Of course, the comprehensiveness and certainty of the outcome will vary with the amount and quality of information employed. The guidelines can be applied in an iterative fashion to improve management understanding as the information improves. Wetlands Guidance Appendix 1 lists the information needed to perform basic analyses, followed by other information that can improve the understanding and analysis.
5. These guidelines emphasize avoiding structural, hydrologic, and water quality **modifications** of existing wetlands to the extent possible in the process of urbanization and the management of urban stormwater runoff.
6. In pursuit of this goal, the guidelines take a systematic approach to management problems that potentially involve both urban stormwater (quantity, quality, or both) and wetlands. The consideration of wetlands involves their area extent, **values**, and functions. This approach emphasizes a comprehensive analysis of alternatives to solve the identified problem. The guidelines encourage conducting the analysis on a landscape scale and considering all of the possible stormwater management alternatives, which may or may not involve a wetland. They favor **source control best management practices** (BMPs) and **pre-treatment** of stormwater runoff prior to release to wetlands.
7. Furthermore, the guidelines take a holistic view of managing wetland resources in an urban setting. Thus, they recognize that urban wetlands have the potential to be affected structurally and functionally whether or not they are formally designated for stormwater management purposes. Even if an urban wetland is not structurally or hydrologically engineered for such purposes, it may experience altered hydrology (more or less water), reduced water quality, and a host of other impacts related to urban conditions. It is the



objective of the guidelines to avoid or reduce the negative effects on wetland resources from both specific stormwater management actions and incidental urban impacts.

### Support Material

1. The guidelines use certain terms that require definition to ensure that the intended meaning is conveyed to all users. Such terms are printed in **boldface** the first time that they appear in each guide sheet, and are defined in Wetlands Guidance Appendix B.
2. The guideline provisions were drawn principally from the available results of the Puget Sound Wetlands and Stormwater Management Research Program, as set forth in Sections 2 and 3 of the program's summary publication, *Wetlands and Urbanization, Implications for the Future* (Horner et al. 1996). Where the results in this publication are the basis for a numerical provision, a separate reference is not given. Numerical provisions based on other sources are referenced. See Wetlands Guidance References at the end of this appendix.
3. Appendix 3 presents a list of plant species native to wetlands in the Puget Sound Region. This appendix is intended for reference by guideline users who are not specialists in wetland botany. However, non-specialists should obtain expert advice when making decisions involving vegetation.
4. Appendix 4 compares the water chemistry characteristics of *Sphagnum* bog and fen wetlands (termed **priority peat wetlands** in these guidelines) with more common wetland communities. These bogs and fens appear to be the most sensitive among the Puget Sound lowland wetlands to alteration of water chemistry, and require special water quality management to avoid losses of their relatively rare communities.

# Guide Sheet 1: Comprehensive Landscape Planning for Wetlands and Stormwater Management

**Wetlands** in newly developing areas will receive urban effects even if not specifically "used" in stormwater management. Therefore, the task is proper overall management of the resources and protection of their general **functioning**, including their role in storm drainage systems. Stormwater management in newly developing areas is distinguished from management in already developed locations by the existence of many more feasible stormwater control options prior to development. The guidelines emphasize appropriate selection among the options to achieve optimum overall resource protection benefits, extending to downstream receiving waters and ground water aquifers, as well as to wetlands.

The comprehensive planning guidelines are based on two principles that are recognized to create the most effective environmental management: (1) the best management policies for the protection of wetlands and other natural resources are those that prevent or minimize the development of impacts at potential sources; and (2) the best management strategies are self-perpetuating, that is they do not require periodic infusions of capital and labor. To apply these principles in managing wetlands in a newly developing area, carry out the following steps.

## Guide Sheet 1A: Comprehensive Planning Steps

1. Define the **landscape unit** subject to comprehensive planning. Refer to the definition of landscape unit in Appendix 2 for assistance in defining it.
2. Begin the development of a plan for the landscape unit with attention to the following general principles:
  - Formulate the plan on the basis of clearly articulated community goals. Carefully identify conflicts and choices between retaining and protecting desired resources and community growth.
  - Map and assess land suitability for urban uses. Include the following landscape features in the assessment: forested land, open unforested land, steep slopes, erosion-prone soils, foundation suitability, soil suitability for waste disposal, aquifers, aquifer recharge areas, wetlands, floodplains, surface waters, agricultural lands, and various categories of urban land use. When appropriate, the assessment can highlight outstanding local or regional resources that the community determines should be protected (e. g., a fish run, scenic area, recreational area, threatened species habitat, farmland). Mapping and assessment should recognize not only these resources but also additional areas needed for their sustenance.
3. Maximize natural water storage and infiltration opportunities within the landscape unit and outside of existing wetlands, especially:
  - Promote the conservation of forest cover. Building on land that is already deforested affects basin hydrology to a lesser extent than converting forested land. Loss of forest cover reduces interception storage, detention in the organic forest floor layer, and water losses by evapotranspiration, resulting in large peak runoff increases and either their negative effects or the expense of countering them with structural solutions.

- Maintain natural storage reservoirs and drainage corridors, including depressions, areas of permeable soils, swales, and intermittent streams. Develop and implement policies and regulations to discourage the clearing, filling, and channelization of these features. Utilize them in drainage networks in preference to pipes, culverts, and engineered ditches.
  - In evaluating infiltration opportunities refer to the stormwater management manual for the jurisdiction and pay particular attention to the selection criteria for avoiding groundwater contamination and poor soils and hydrogeological conditions that cause these facilities to fail. If necessary, locate developments with large amounts of impervious surfaces or a potential to produce relatively contaminated runoff away from groundwater recharge areas. Relatively dense developments on glacial outwash soils may require additional runoff treatment to protect groundwater quality.
4. Establish and maintain **buffers** surrounding wetlands and in riparian zones as required by local regulations or recommended by the Puget Sound Water Quality Authority's wetland guidelines. Also, maintain interconnections among wetlands and other natural habitats to allow for wildlife movements.
  5. Determine whether the wetland has a breeding, native amphibian population. A survey should be conducted in the spring.
  6. Take specific management measures to avoid general urban impacts on wetlands and other water bodies (e. g., littering, vegetation destruction, human and pet intrusion harmful to wildlife).
  7. To support management of runoff water quantity, perform a hydrologic analysis of the contributing drainage catchment to define the type and extent of flooding and stream channel erosion problems associated with existing development, redevelopment, or new development that require control to protect the beneficial uses of receiving waters, including wetlands. This analysis should include assembly of existing flow data and hydrologic modeling as necessary to establish conditions limiting to attainment of beneficial uses. Modeling should be performed as directed by the stormwater management manual in effect in the jurisdiction.
  8. In wetlands previously relatively unaffected by human activities, manage stormwater quantity to attempt to match the **pre-development hydroperiod** and **hydrodynamics**. In wetlands whose hydrology has been disturbed, consider ways of reducing hydrologic impacts. This provision involves not only management of high runoff volumes and rates of flow during the wet season, but also prevention of water supply depletion during the dry season. The latter guideline may require flow augmentation if urbanization reduces existing surface or groundwater inflows. Refer to Guide Sheet 2, Wetland Protection Guidelines, for detail on implementing these guidelines.
  9. Assess alternatives for the control of runoff water quantities as follows:
    - a. Define the runoff quantity problem subject to management by analyzing the proposed land development action.
    - b. For existing development or **redevelopment**, assess possible alternative solutions that are applicable at the site of the problem occurrence, including:

- Protect health, safety, and property from flooding by removing habitation from the flood plain.
  - Prevent stream channel erosion by stabilizing the eroding bed and/or bank area with **bioengineering** techniques, preferably, or by structurally reinforcing it, if this solution would be consistent with the protection of aquatic habitats and beneficial uses of the stream (refer to Chapter 173-201A of the Washington Administrative Code (WAC) for the definition of beneficial uses).
- c. For new development or redevelopment, assess possible regulatory and incentive land use control alternatives, such as density controls, clearing limits, impervious surface limits, transfer of development rights, purchase of conservation areas, etc.
- d. If the alternatives considered in Steps 9a or 9b cannot solve an existing or potential problem, perform an analysis of the contributing drainage catchment to assess possible alternative solutions that can be applied **on-site** or on a **regional** scale. The most appropriate solution or combination of alternatives should be selected with regard to the specific opportunities and constraints existing in the drainage catchment. For new development or redevelopment, on-site facilities that should be assessed include, in approximate order of preference:
- Infiltration basins or trenches;
  - Retention/detention ponds;
  - Below-ground vault or tank storage;
  - Parking lot detention.

Regional facilities that should be assessed for solving problems associated with new development, redevelopment, or existing development include:

- Infiltration basins or trenches;
  - Detention ponds;
  - **Constructed wetlands;**
  - Bypassing a portion of the flow to an acceptable receiving water body, with treatment as required to protect water quality and other special precautions as necessary to prevent downstream impacts.
- e. Consider structurally or hydrologically engineering an existing wetland for water quantity control only if upland alternatives are inadequate to solve the existing or potential problem. To evaluate the possibility, refer to the Storm-water Wetland Assessment Criteria in Guide Sheet 1B.
10. Place strong emphasis on water resource protection during construction of new development. Establish effective erosion control programs to reduce the sediment loadings to receiving waters to the maximum extent possible. No preexisting wetland or other water body should ever be used for the sedimentation of solids in construction-phase runoff.
11. In wetlands previously relatively unaffected by human activities, manage stormwater quality to attempt to match pre-development water quality conditions. To support management of runoff water quality, perform an analysis of the contributing drainage

catchment to define the type and extent of runoff water quality problems associated with existing development, redevelopment, or new development that require control to protect the beneficial uses of receiving waters, including wetlands. This analysis should incorporate the hydrologic assessment performed under step 7 and include identification of key water pollutants, which may include solids, oxygen-demanding substances, nutrients, metals, oils, trace organics, and bacteria, and evaluation of the potential effects of water pollutants throughout the drainage system.

12. Assess alternatives for the control of runoff water quality as follows:

- a. Perform an analysis of the contributing drainage catchment to assess possible alternative solutions that can be applied on-site or on a regional scale. The most appropriate solution or combination of alternatives should be selected with regard to the specific opportunities and constraints existing in the drainage catchment. Consider both **source control BMPs** and **treatment BMPs** as alternative solutions before considering use of existing wetlands for quality improvement according to the following considerations:
  - Implementation of source control BMPs prevent the generation or release of water pollutants at potential sources. These alternatives are generally both more effective and less expensive than treatment controls. They should be applied to the maximum extent possible to new development, redevelopment, and existing development.
  - Treatment BMPs capture water pollutants after their release. This alternative often has limited application in existing developments because of space limitations, although it can be employed in new development and when redevelopment occurs in already developed areas. Refer to Minimum Requirement #6 in Volume 1 of the Stormwater Management Manual for Western Washington to determine whether a treatment facility is necessary for your site. If a facility is required, refer to Chapter 4 of Volume 1, or Chapter 2 of Volume 5 to determine which treatment requirement – basic, enhanced, phosphorus, or oil control - applies to your site. Then refer to the corresponding BMP menu for that requirement in Chapter 3 of Volume V. From the menu select a BMP that fits with your project site.
- b. Consider structurally or hydrologically engineering an existing wetland for water quality control only if upland alternatives are inadequate to solve the existing or potential problem. Use of Waters of the State and Waters of the United States, including wetlands, for the treatment or conveyance of wastewater, including stormwater, is prohibited under state and federal law. Discussions with federal and state regulators during the research program led to development of a statement concerning the use of existing wetlands for improving stormwater quality (**polishing**), as follows. Such use is subject to analysis on a case-by-case basis and may be allowed only if the following conditions are met:
  - If **restoration** or **enhancement** of a previously **degraded** wetland is required, and if the upgrading of other wetland functions can be accomplished along with benefiting runoff quality control, and

- If appropriate source control and treatment BMPs are applied in the contributing catchment on the basis of the analysis in Step 12a, and any legally adopted water quality standards for wetlands are observed.

If these circumstances apply, refer to the Stormwater Wetland Assessment Criteria in Guide Sheet 1B to evaluate further.

13. Stimulate public awareness of and interest in wetlands and other water resources in order to establish protective attitudes in the community. This program should include:
  - Education regarding the use of fertilizers and pesticides, automobile maintenance, the care of animals to prevent water pollution, and the importance of retaining buffers;
  - Descriptive signboards adjacent to wetlands informing residents of the wetland type, its functions, the protective measures being taken, etc.
  - If beavers are present in a wetland, educate residents about their ecological role and value and take steps to avoid human interference with beavers.

### **Guide Sheet 1B: Stormwater Wetland Assessment Criteria**

This guide sheet gives criteria that disqualify a natural wetland from being structurally or hydrologically engineered for control of stormwater quantity, quality, or both. These criteria should be applied only after performing the alternatives analysis outlined in Guide Sheet 1A.

1. A wetland should not be structurally or hydrologically engineered for runoff quantity or quality control and should be given maximum protection from overall urban impacts (see Guide Sheet 2, Wetland Protection Guidelines) under any of the following circumstances:
  - In its present state it is primarily an **estuarine** or **forested wetland** or a **priority peat system**.
  - It is a rare or irreplaceable wetland type, as identified by the Washington Natural Heritage Program, the Puget Sound Water Quality Preservation Program, or local government.
  - It provides **rare, threatened, or endangered species** habitat that could be impaired by the proposed action. Determining whether or not the conserved species will be affected by the proposed project requires a careful analysis of its requirements in relation to the anticipated habitat changes.

In general, the wetlands in these groups are classified in Categories I and II in the Puget Sound Water Quality Authority's draft wetland guidelines.

2. A wetland can be considered for structural or hydrological modification for runoff quantity or quality control if most of the following circumstances exist:
  - It is classified in Category IV in the Puget Sound Water Quality Authority's draft wetland guidelines. In general, Category IV wetlands have monotypic vegetation of similar age and class, lack special habitat features, and are isolated from other aquatic systems.

- The wetland has been previously **disturbed** by human activity, as evidenced by agriculture, fill, ditching, and/or introduced or **invasive weedy plant species**.
- The wetland has been deprived of a significant amount of its water supply by draining or previous urbanization (e. g., by loss of groundwater supply), and stormwater runoff is sufficient to augment the water supply. A particular candidate is a wetland that has experienced an increased summer dry period, especially if the drought has been extended by more than two weeks.
- Construction for structural or hydrologic modification in order to provide runoff quantity or quality control will disturb relatively little of the wetland.
- The wetland can provide the required storage capacity for quantity or quality control through an outlet orifice modification to increase storage of water, rather than through raising the existing overflow. Orifice modification is likely to require less construction activity and consequent negative impacts.
- Under existing conditions the wetland's experiences a relatively high degree of water level fluctuation and a range of velocities (i.e., a wetland associated with substantially flowing water, rather than one in the headwaters or entirely isolated from flowing water).
- The wetland does not exhibit any of the following features:
  - Significant priority peat system or forested zones that will experience substantially altered hydroperiod as a result of the proposed action;
  - Regionally **unusual biological community types**;
  - Animal habitat features of relatively high value in the region (e. g., a protected, undisturbed area connected through undisturbed corridors to other valuable habitats, an important breeding site for protected species);
  - The presence of protected commercial or sport fish;
  - Configuration and topography that will require significant modification that may threaten fish stranding;
  - A relatively high degree of public interest as a result of, for example, offering valued local open space or educational, scientific, or recreational opportunities, unless the proposed action would enhance these opportunities;
- The wetland is threatened by potential impacts exclusive of stormwater management, and could receive greater protection if acquired for a stormwater management project rather than left in existing ownership.
- There is good evidence that the wetland actually can be restored or enhanced to perform other functions in addition to runoff quantity or quality control.
- There is good evidence that the wetland lends itself to the effective application of the Wetland Protection Guidelines in Guide Sheet 2.
- The wetland lies in the natural routing of the runoff. Local regulations often prohibit drainage diversion from one basin to another.
- The wetland allows runoff discharge at the natural location.

## Guide Sheet 2: Wetland Protection Guidelines

This guide sheet provides information about likely changes to the ecological **structure** and **functioning** of **wetlands** that are incidentally subject to the effects of an urban or urbanizing watershed or are **modified** to supply runoff water quantity or quality control benefits. The guide sheet also recommends management actions that can avoid or minimize deleterious changes in these wetlands.

### Guide Sheet 2A: General Wetland Protection Guidelines

1. Consult regulations issued under federal and state laws that govern the discharge of pollutants. Wetlands are classified as "Waters of the United States" and "Waters of the State" in Washington.
2. Maintain the wetland **buffer** required by local regulations or recommended by the Puget Sound Water Quality Authority's draft wetland guidelines.
3. Retain areas of native vegetation connecting the wetland and its buffer with nearby wetlands and other contiguous areas of native vegetation.
4. Avoid compaction of soil and introduction of exotic plant species during any work in a wetland.
5. Take specific site design and maintenance measures to avoid general urban impacts (e. g., littering and vegetation destruction). Examples are protecting existing buffer zones; discouraging access, especially by vehicles, by plantings outside the wetland; and encouragement of stewardship by a homeowners' association. Fences can be useful to restrict dogs and pedestrian access, but they also interfere with wildlife movements. Their use should be very carefully evaluated on the basis of the relative importance of intrusive impacts versus wildlife presence. Fences should generally not be installed when wildlife would be restricted and intrusion is relatively minor. They generally should be used when wildlife passage is not a major issue and the potential for intrusive impacts is high. When wildlife movements and intrusion are both issues, the circumstances will have to be weighed to make a decision about fencing.
6. If the wetland inlet will be modified for the stormwater management project, use a diffuse flow method, such as a spreader swale, to discharge water into the wetland in order to prevent flow channelization.

### Guide Sheet 2B: Guidelines for Protection from Adverse Impacts of Modified Runoff Quantity Discharged to Wetlands

1. Protection of wetland plant and animal communities depends on controlling the wetland's **hydroperiod**, meaning the pattern of fluctuation of water depth and the frequency and duration of exceeding certain levels, including the length and onset of drying in the summer. A hydrologic assessment is useful to measure or estimate elements of the hydroperiod under existing **pre-development** and anticipated **post-development** conditions. This assessment should be performed with the aid of a qualified hydrologist. Post-development estimates of watershed hydrology and wetland hydroperiod must include the cumulative effect of all anticipated watershed and wetland modifications. Provisions in these guidelines pertain to the full anticipated build-out of the wetland's watershed.



This analysis hypothesizes a fluctuating water stage over time before development that could fluctuate more, both higher and lower after development; these greater fluctuations are termed **stage excursions**. The guidelines set limits on the frequency and duration of excursions, as well as on overall water level fluctuation, after development.

To determine existing hydroperiod use one of the following methods, listed in order of preference:

- Estimation by a continuous simulation computer model--The model should be calibrated with at least one year of data taken using a continuously recording level gage under existing conditions and should be run for the historical rainfall period. The resulting data can be used to express the magnitudes of depth fluctuation, as well as the frequencies and durations of surpassing given depths. [Note: Modeling that yields high quality information of the type needed for wetland hydroperiod analysis is a complex subject. Providing guidance on selecting and applying modeling options is beyond the scope of these guidelines but is being developed by King County Surface Water Management Division and other local jurisdictions. An alternative possibility to modeling depths, frequencies, and durations within the wetland is to model durations above given discharge levels entering the wetland over various time periods (e. g., seasonal, monthly, weekly). This option requires further development.]
- Measurement during a series of time intervals (no longer than one month in length) over a period of at least one year of the maximum water stage, using a crest stage gage, and instantaneous water stage, using a staff gage--The resulting data can be used to express water level fluctuation (WLF) during the interval as follows:

Average base stage = (Instantaneous stage at beginning of interval + Instantaneous stage at end of interval)/2

WLF = Crest stage - Average base stage

Compute mean annual and mean monthly WLF as the arithmetic averages for each year and month for which data are available.

To forecast future hydroperiod use one of the following methods, listed in order of preference:

- Estimation by the continuous simulation computer model calibrated during pre-development analysis and run for the historical rainfall period--The resulting data can be used to express the magnitudes of depth fluctuation, as well as the frequencies and durations of surpassing given depths. [Note: Post-development modeling results should generally be compared with pre-development modeling results, rather than directly with field measurements, because different sets of assumptions underlie modeling and monitoring. Making pre- and post-development comparisons on the basis of common assumptions allows cancellation of errors inherent in the assumptions.]
- Estimation according to general relationships developed from the Puget Sound Wetlands and Stormwater Management Program Research Program, as follows (in part adapted from Chin 1996):

- Mean annual WLF is very likely (100% of cases measured) to be < 20 cm (8 inches or 0.7 ft) if total impervious area (TIA) cover in the watershed is < 6% (roughly corresponding to no more than 15% of the watershed converted to urban land use).
  - Mean annual WLF is very likely (89% of cases measured) to be > 20 cm if TIA in the watershed is > 21% (roughly corresponding to more than 30% of the watershed converted to urban land use).
  - Mean annual WLF is somewhat likely (50% of cases measured) to be > 30 cm (1.0 ft) if TIA in the watershed is > 21% (roughly corresponding to more than 30% of the watershed converted to urban land use).
  - Mean annual WLF is likely (75% of cases measured) to be > 30 cm, and somewhat likely (50% of cases measured) to be 50 cm (20 inches or 1.6 ft) or higher, if TIA in the watershed is > 40% (roughly corresponding to more than 70% of the watershed converted to urban land use).
  - The frequency of stage excursions greater than 15 cm (6 inches or 0.5 ft) above or below pre-development levels is somewhat likely (54% of cases measured) to be more than six per year if the mean annual WLF increases to > 24 cm (9.5 inches or 0.8 ft).
  - The average duration of stage excursions greater than 15 cm above or below pre-development levels is likely (69% of cases measured) to be more than 72 hours if the mean annual WLF increases to > 20 cm.
2. The following hydroperiod limits characterize wetlands with relatively high vegetation species richness and apply to all zones within all wetlands over the entire year. If these limits are exceeded, then species richness is likely to decline. If the analysis described above forecasts exceedences, one or more of the management strategies listed in step 5 should be employed to attempt to stay within the limits.
- Mean annual WLF (and mean monthly WLF for every month of the year) does not exceed 20 cm. Vegetation species richness decrease is likely with: (1) a mean annual (and mean monthly) WLF increase of more than 5 cm (2 inches or 0.16 ft) if pre-development mean annual (and mean monthly) WLF is greater than 15 cm, or (2) a mean annual (and mean monthly) WLF increase to 20 cm or more if pre-development mean annual (and mean monthly) WLF is 15 cm or less.
  - The frequency of stage excursions of 15 cm above or below pre-development stage does not exceed an annual average of six. Note: A short-term lagging or advancement of the continuous record of water levels is acceptable. The 15 cm limit applies to the temporary increase in maximum water surface elevations (hydrograph peaks) after storm events and the maximum decrease in water surface elevations (hydrograph valley bottoms) between events and during the dry season.
  - The duration of stage excursions of 15 cm above or below pre-development stage does not exceed 72 hours per excursion. Note: A short-term lagging or advancement of the continuous record of water levels is acceptable. However, the 15 cm limit applies throughout the entire hydrograph, not just the peaks and valleys.

- The total dry period (when pools dry down to the soil surface everywhere in the wetland) does not increase or decrease by more than two weeks in any year.
  - Alterations to watershed and wetland hydrology that may cause perennial wetlands to become **vernal** are avoided.
3. The following hydroperiod limit characterizes **priority peat wetlands** (bogs and fens as more specifically defined by the Washington Department of Ecology) and applies to all zones over the entire year. If this limit is exceeded, then characteristic bog or fen wetland vegetation is likely to decline. If the analysis described above forecasts exceedence, one or more of the management strategies listed in step 5 should be employed to attempt to stay within the limit.
- The duration of stage excursions above the pre-development stage does not exceed 24 hours in any year.
  - Note: This guideline is in addition to the guidelines in #2 directly above. To apply this guideline a continuous simulation computer model needs to be employed. The model should be calibrated with data taken under existing conditions at the wetland being analyzed and then used to forecast post-development duration of excursions.
4. The following hydroperiod limits characterize wetlands inhabited by breeding native amphibians and apply to breeding zones during the period 1 February through 31 May. If these limits are exceeded, then amphibian breeding success is likely to decline. If the analysis described above forecasts exceedences, one or more of the management strategies listed in step 5 should be employed to attempt to stay within the limits.
- The magnitude of stage excursions above or below the pre-development stage should not exceed 8 cm for more than 24 hours in any 30-day period.
  - Note: To apply this guideline a continuous simulation computer model needs to be employed. The model should be calibrated with data taken under existing conditions at the wetland being analyzed and then used to forecast post-development magnitude and duration of excursions.
5. If it is expected that the hydroperiod limits stated above could be exceeded, consider strategies such as:
- Reduction of the level of development;
  - Increasing runoff infiltration [Note: Infiltration is prone to failure in many Puget Sound Basin locations with glacial till soils and generally requires **pretreatment** to avoid clogging. In other situations infiltrating urban runoff may contaminate groundwater. Consult the stormwater management manual adopted by the jurisdiction and carefully analyze infiltration according to its prescriptions.];
  - Increasing runoff storage capacity; and
  - Selective runoff bypass.
6. After development, monitor hydroperiod with a continuously recording level gauge or staff and crest stage gauges. If the applicable limits are exceeded, consider additional applications of the strategies in step 5 that may still be available. It is also recommended

that goals be established to maintain key vegetation species, amphibians, or both, and that these species be monitored to determine if the goals are being met.

## **Guide Sheet 2C: Guidelines for Protection from Adverse Impacts of Modified Runoff Quality Discharged to Wetlands**

1. Require effective erosion control at any construction sites in the wetland's drainage catchment.
2. Institute a program of **source control BMPs** to minimize the generation of pollutants that will enter storm runoff that drains to the wetland.
3. Provide a water quality control facility consisting of one or more **treatment BMPs** to treat all urban runoff entering the wetland. Refer to Chapter 4 of Volume 1 or Chapter 2 of Volume V of the Stormwater Management Manual for Western Washington to determine treatment requirements. Then refer to the corresponding BMP menu for that requirement in Chapter 3 of Volume V. From the menu select a BMP that fits with the project site.
  - If the wetland is a **priority peat wetland** (bogs and fens as more specifically defined by the Washington Department of Ecology), the facility should include a BMP with the most advanced ability to control nutrients (e. g., an infiltration device, a wet pond or constructed wetland with residence time in the pooled storage of at least two weeks). [Note: Infiltration is prone to failure in many Puget Sound Basin locations with glacial till soils and generally requires **pretreatment** to avoid clogging. In other situations infiltrating urban runoff may contaminate groundwater. Consult the stormwater management manual adopted by the jurisdiction and carefully analyze infiltration according to its prescriptions.] Refer to Appendix 4 for a comparison of water chemistry conditions in priority peat versus more typical wetlands.

Refer to the stormwater management manual to select and design the facility. Generally, the facility should be located outside and upstream of the wetland and its buffer.

4. Design and perform a water quality monitoring program for priority peat wetlands and for other wetlands subject to relatively high water pollutant loadings. The research results (Horner 1989) identified such wetlands as having contributing catchments exhibiting either of the following characteristics:
  - More than 20 percent of the catchment area is committed to commercial, industrial, and/or multiple family residential land uses; or
  - The combination of all urban land uses (including single family residential) exceeds 30 percent of the catchment area.

A recommended monitoring program, consistent with monitoring during the research program, is:

- Perform pre-development **baseline sampling** by collecting water quality grab samples in an open water pool of the wetland for at least one year, allocated through the year as follows: November 1-March 31--4 samples, April 1-May 31--1 sample, June 1-August 31--2 samples, and September 1-October 31--1 sample (if the wetland is dry during any

period, reallocate the sample(s) scheduled then to another time). Analyze samples for pH; dissolved oxygen (DO); conductivity (Cond); total suspended solids (TSS); total phosphorus (TP); nitrate + nitrite-nitrogen (N); fecal coliforms (FC); and total copper (Cu), lead (Pb), and zinc (Zn). Find the median and range of each water quality variable.

- Considering the baseline results, set water quality goals to be maintained in the post-development period. Example goals are: (1) pH--no more than “x” percent (e. g., 10%) increase (relative to baseline) in annual median and maximum or decrease in annual minimum; (2) DO--no more than “x” percent decrease in annual median and minimum concentrations; (3) other variables --no more than “x” percent increase in annual median and maximum concentrations; (4) no increase in violations of the Washington Administrative Code (WAC) water quality criteria.
- Repeat the sampling on the same schedule for at least one year after all development is complete. Compare the results to the set goals.

If the water quality goals are not met, consider additional applications of the source and treatment controls described in steps 2 and 3. Continue monitoring until the goals are met at least two years in succession.

Note: Wetland water quality was found to be highly variable during the research, a fact that should be reflected in goals. Using the maximum (or minimum), as well as a measure of central tendency like the median, and allowing some change from pre-development levels are ways of incorporating an allowance for variability. Table D.1 presents data from the wetlands studied during the research program to give an approximate idea of magnitudes and degree of variability to be expected. Nonurbanized watersheds (N) are those that have both < 15% urbanization and < 6% impervious cover. Highly urbanized watersheds (H) are those that have both lost all forest cover and have > 20% impervious cover. Moderately urbanized watersheds (M) are those that fit neither the N nor H category.

Metric	N			M			H		
	Median	Mean	Std.Dev./n <sup>a</sup>	Median	Mean	Std.Dev./n <sup>a</sup>	Median	Mean	Dev./n <sup>a</sup>
pH <sup>b</sup>	6.4	6.4	0.5/162	6.7	6.5	0.8/132	6.9	6.7	0.6/52
DO (mg/L)	5.9	5.7	2.6/205	5.1	5.53.6/173	6.3	5.4	2.9/67	
Cond. (µS/cm)	46	73	64/190	160	142	73/161	132	151	86/61
TSS (µg/L)	2.0	4.6	8.5/204	2.8	9.2	22/175	4.0	9.2	15/66
TP (µg/L)	29	52	87/206	70	93	92/177	69	110	234/67
N (µg/L)	112	368	485/206	304	598	847/177	376	395	239/67
FC (no./100mL)	9.0	271	1000/206	46	2665	27342/173	61	969	4753/66
Cu (µg/L)	<5.0	<3.3	>2.7/93	<5.0	<3.7	>1.9/78	<5.0	<4.1	<2.5/29
Pb (µg/L)	1.0	<2.7	>2.8/136	3.0	<3.4	>2.7/122	5.0	<4.5	>4.0/44
Zn (µg/L)	5.0	8.4	8.3/136	8.0	9.8	7.2/122	20	20	17/44

<sup>a</sup> Std. Dev.--standard deviation; n--number of observations.

<sup>b</sup> Values do not apply to priority peat wetlands. The program did not specifically study these wetlands but measured pH in three wetlands with “bog-like” characteristics. The minimum value measured in these wetlands was 4.5, and the lowest median was 4.8; but pH can be approximately 1 unit lower in wetlands of this type.

## Guide Sheet 2D: Guidelines for the Protection of Specific Biological Communities

### 1. For wetlands inhabited by breeding native amphibians:

- Refer to step 4 of Guide Sheet 2B for hydroperiod limit.
- Avoid decreasing the sizes of the open water and aquatic bed zones.
- Avoid increasing the channelization of flow. Do not form channels where none exist, and take care that inflows to the wetland do not become more concentrated and do not enter at higher velocities than accustomed. If necessary, concentrated flows can be uniformly distributed with a flow-spreading device such as a shallow weir, stilling basin, or perforated pipe. Velocity dissipation can be accomplished with a stilling basin or rip-rap pad.
- Limit the post-development flow velocity to < 5 cm/s (0.16 ft/second) in any location that had a velocity in the range 0-5 cm/s in the pre-development condition.
- Avoid increasing the gradient of wetland side slopes.

### 2. For wetlands inhabited by forest bird species:

Retain areas of coniferous forest in and around the wetland as habitat for forest species.

Retain shrub or woody debris as nesting sites for ground-nesting birds and downed logs and stumps for winter wren habitat.

Retain snags as habitat for cavity-nesting species, such as woodpeckers.

Retain shrubs in and around the wetland for protective cover. If cover is insufficient to protect against domestic pet predation, consider planting native bushes such as rose species in the buffer.

### 3. For wetlands inhabited by wetland obligate bird species:

- Retain **forested zones**, sedge and rush meadows, and deep open water zones, both without vegetation and with submerged and floating plants.
- Retain shrubs in and around the wetland for protective cover. If cover is insufficient to protect against domestic pet predation, consider planting native bushes such as rose species in the buffer.
- Avoid introducing **invasive weedy plant species**, such as purple loosestrife and reed canary grass.
- Retain the buffer zone. If it has lost width or forest cover, consider re-establishing forested buffer area at least 30 meters (100 ft) wide.
- If human entry is desired, establish paths that permit people to observe the wetland with minimum disturbance to the birds.

### 4. For wetlands inhabited by fish:

- Protect fish habitats by avoiding water velocities above tolerated levels (selected with the aid of a qualified fishery biologist to protect fish in each life stage when they are present), siltation of spawning beds, etc. Habitat requirements vary substantially among fish species. If the wetland is associated with a larger water body, contact the Department of Fisheries and Wildlife to determine the species of concern and the acceptable ranges of habitat variables.

- If stranding of protected commercial or sport fish could result from a structural or hydrologic modification for runoff quantity or quality control, develop a strategy to avoid stranding that minimizes disturbance in the wetland (e. g., by making provisions for fish return to the stream as the wetland drains, or avoiding use of the facility for quantity or quality control during fish presence).

## **Wetlands Guidance Appendix 1: Information Needed to Apply Guidelines**

The following information listed for each guide sheet is most essential for applying the Wetlands and Stormwater Management Guidelines. As a start, obtain the relevant soil survey; the National Wetland Inventory, topographic and land use maps, and the results of any local wetland inventory.

### **Guide Sheet 1**

1. Boundary and area of the contributing watershed of the wetland or other landscape unit
2. A complete definition of goals for the wetland and landscape unit subject to planning and management
3. Existing management and monitoring plans
4. Existing and projected land use in the landscape unit in the categories commercial, industrial, multi-family residential, single-family residential, agricultural, various categories of undeveloped, and areas subject to active logging or construction (expressed as percentages of the total watershed area)
5. Drainage network throughout the landscape unit
6. Soil conditions, including soil types, infiltration rates, and positions of seasonal water table (seasonally) and restrictive layers
7. Groundwater recharge and discharge points
8. Wetland category (I - IV in draft Puget Sound Water Quality Authority wetland protection guidelines); designation as rare or irreplaceable. Refer to the Washington Natural Heritage Program database. If the needed information is not available, a biological assessment will be necessary.
9. Watershed hydrologic assessment
10. Watershed water quality assessment
11. Wetland type and zones present, with special note of estuarine, priority peat system, forested, sensitive scrub-shrub zone, sensitive emergent zone and other sensitive or critical areas designated by state or local government (with dominant plant species)
12. Rare, threatened, or endangered species inhabiting the wetland
13. History of wetland changes
14. Relationship of wetland to other water bodies in the landscape unit and the drainage network
15. Flow pattern through the wetland
16. Fish and wildlife inhabiting the wetland
17. Relationship of wetland to other wildlife habitats in the landscape unit and the corridors between them



## **Guide Sheet 2**

1. Existing and potential stormwater pollution sources
2. Existing and projected landscape unit land use (see number 4 under Guide Sheet 1)
3. Existing and projected wetland hydroperiod characteristics
4. Wetland bathymetry
5. Inlet and outlet locations and hydraulics
6. Landscape unit soils, geologic and hydrogeologic conditions
7. Wetland type and zones present (see number 11 under Guide Sheet 1)
8. Presence of breeding populations of native amphibian species
9. Presence of forest and wetland obligate bird species
10. Presence of fish species

## Wetlands Guidance Appendix 2: Definitions

<b>Baseline sampling</b>	Sampling performed to define an existing state before any modification occurs that could change the state.
<b>Bioengineering</b>	Restoration or reinforcement of slopes and stream banks with living plant materials.
<b>Buffer</b>	The area that surrounds a wetland and that reduces adverse impacts to it from adjacent development.
<b>Constructed wetland</b>	A wetland intentionally created from a non-wetland site for the sole purpose of wastewater or stormwater treatment. These wetlands are not normally considered Waters of the United States or Waters of the State.
<b>Degraded (disturbed) wetland (community)</b>	A wetland (community) in which the vegetation, soils, and/or hydrology have been adversely altered, resulting in lost or reduced functions and values; generally, implies topographic isolation; hydrologic alterations such as hydroperiod alteration (increased or decreased quantity of water), diking, channelization, and/or outlet modification; soils alterations such as presence of fill, soil removal, and/or compaction; accumulation of toxicants in the biotic or abiotic components of the wetland; and/or low plant species richness with dominance by invasive weedy species
<b>Enhancement</b>	Actions performed to improve the condition of an existing degraded wetland, so that functions it provides are of a higher quality.
<b>Estuarine wetland</b>	Generally, an eelgrass bed; salt marsh; or rocky, sandflat, or mudflat intertidal area where fresh and salt water mix. (Specifically, a tidal wetland with salinity greater than 0.5 parts per thousand, usually semi-enclosed by land but with partly obstructed or sporadic access to the open ocean).
<b>Forested communities (wetlands)</b>	In general terms, communities (wetlands) characterized by woody vegetation that is greater than or equal to 6 meters in height; in these guidelines the term applies to such communities (wetlands) that represent a significant amount of tree cover consisting of species that offer wildlife habitat and other values and advance the performance of wetland functions overall.

<b>Functions</b>	The ecological (physical, chemical, and biological) processes or attributes of a wetland without regard for their importance to society (see also Values). Wetland functions include food chain support, provision of ecosystem diversity and fish and wildlife habitat, flood flow alteration, groundwater recharge and discharge, water quality improvement, and soil stabilization.
<b>Hydrodynamics</b>	The science involving the energy and forces acting on water and its resulting motion.
<b>Hydroperiod</b>	The seasonal occurrence of flooding and/or soil saturation; encompasses the depth, frequency, duration, and seasonal pattern of inundation.
<b>Invasive weedy plant species</b>	Opportunistic species of inferior biological value that tend to out-compete more desirable forms and become dominant; applied to non-native species in these guidelines.
<b>Landscape unit</b>	An area of land that has a specified boundary and is the locus of interrelated physical, chemical, and biological processes.
<b>Modification, Modified (wetland)</b>	A wetland whose physical, hydrological, or water quality characteristics have been purposefully altered for a management purpose, such as by dredging, filling, forebay construction, and inlet or outlet control.
<b>On-site</b>	An action (here, for stormwater management purposes) taken within the property boundaries of the site to which the action applies.
<b>Polishing</b>	Advanced treatment of a waste stream that has already received one or more stages of treatment by other means.
<b>Pre-development, post-development</b>	Respectively, the situation before and after a specific stormwater management project (e. g., raising the outlet, building an outlet control structure) will be placed in the wetland or a land use change occurs in the landscape unit that will potentially affect the wetland.
<b>Pre-treatment</b>	An action taken to remove pollutants from runoff before it is discharged into another system for additional treatment.
<b>Priority peat systems</b>	Unique, irreplaceable fens that can exhibit water pH in a wide range from highly acidic to alkaline, including fens typified by <i>Sphagnum</i> species, <i>Rhododendron groenlandicum</i> (Labrador tea), <i>Drosera rotundifolia</i> (sundew), and <i>Vaccinium oxycoccos</i> (bog cranberry); marl fens; estuarine peat deposits; and other moss peat systems with relatively diverse, undisturbed flora and fauna. Bog is the common name for peat systems having the <i>Sphagnum</i> association described, but this term applies strictly only to systems that receive water income from precipitation exclusively.

<b>Rare, threatened, or endangered species</b>	Plant or animal species that are regional relatively uncommon, are nearing endangered status, or whose existence is in immediate jeopardy and is usually restricted to highly specific habitats. Threatened and endangered species are officially listed by federal and state authorities, whereas rare species are unofficial species of concern that fit the above definitions.
<b>Redevelopment</b>	Conversion of an existing development to another land use, or addition of a material improvement to an existing development.
<b>Regional</b>	An action (here, for stormwater management purposes) that involves more than one discrete property.
<b>Restoration</b>	Actions performed to reestablish wetland functional characteristics and processes that have been lost by alterations, activities, or catastrophic events in an area that no longer meets the definition of a wetland.
<b>Source control best management practices (BMPs)</b>	Actions that are taken to prevent the development of a problem (e. g., increase in runoff quantity, release of pollutants) at the point of origin.
<b>Stage excursion</b>	A post-development departure, either higher or lower, from the water depth existing under a given set of conditions in the pre-development state.
<b>Structure</b>	The components of an ecosystem, both the abiotic (physical and chemical) and biotic (living).
<b>Treatment best management practices (BMPs)</b>	Actions that remove pollutants from runoff through one or more physical, chemical, biological mechanisms.
<b>Unusual biological community types</b>	Assemblages of interacting organisms that are relatively uncommon regionally.
<b>Values</b>	Wetland processes or attributes that are valuable or beneficial to society (also see Functions). Wetland values include support of commercial and sport fish and wildlife species, protection of life and property from flooding, recreation, education, and aesthetic enhancement of human communities.
<b>Vernal wetland</b>	A wetland that has water above the soil surface for a period of time during and/or after the wettest season but always dries to or below the soil surface in warmer, drier weather.
<b>Wetland obligate</b>	A biological organism that absolutely requires a wetland habitat for at least some stage of its life cycle.

**Wetlands**

Those areas that are inundated or saturated by surface or ground water at a frequency and duration sufficient to support, and that under normal circumstances do support, a prevalence of vegetation typically adapted for life in saturated soil conditions. Wetlands generally include swamps, marshes, bogs, and similar areas. Wetlands do not include those artificial wetlands intentionally created from nonwetland sites, including, but not limited to, irrigation and drainage ditches, grass-lined swales, canals, detention facilities, wastewater treatment facilities, farm ponds, and landscape amenities, or those wetlands created after July 1, 1990, that were unintentionally created as a result of the construction of a road, street, or highway. Wetlands may include those artificial wetlands intentionally created from nonwetland areas to mitigate the conversion of wetlands. (Waterbodies not included in the definition of wetlands as well as those mentioned in the definition are still waters of the state.)

## Wetlands Guidance Appendix 3: Native and Recommended Noninvasive Plant Species for Wetlands in the Puget Sound Basin

Caution: Extracting plants from an existing wetland donor site can cause a significant negative effect on that site. It is recommended that plants be obtained from native plant nursery stocks whenever possible. Collections from existing wetlands should be limited in scale and undertaken with care to avoid disturbing the wetland outside of the actual point of collection. Plant selection is a complex task, involving matching plant requirements with environmental conditions. It should be performed by a qualified wetlands botanist. Refer to Restoring Wetlands in Washington by the Washington Department of Ecology for more information.

### Plants preferred in Puget Sound Basin freshwater wetlands

#### Open water zone

*Potamogeton* species (pondweeds)  
Nymphaea odorata (pond lily)  
Brasenia schreberi (watershield)  
*Nuphar luteum* (yellow pond lily)  
Polygonum hydropiper (smartweed)  
*Alisma plantago-aquatica* (broadleaf water plantain)  
Ludwigia palustris (water purslane)  
Menyanthes trifoliata (bogbean)  
Utricularia minor, U. vulgaris (bladderwort)

#### Emergent zone:

Carex obnupta, C. utriculata, C. arcta, C. stipata, C. vesicaria C. aquatilis, C. comosa, C. lenticularis (sedge)  
Scirpus atricinctus (woolly bulrush)  
*Scirpus microcarpus* (small-fruited bulrush)  
*Eleocharis palustris*, *E. ovata* (spike rush)  
*Epilobium watsonii* (Watson's willow herb)  
*Typha latifolia* (common cattail) (Note: This native plant can be aggressive but has been found to offer certain wildlife habitat and water quality improvement benefits; use with care.)  
*Veronica americana*, *V. scutellata* (American brookline, marsh speedwell)  
Mentha arvensis (field mint)  
Lycopus americanus, L. uniflora (bugleweed or horehound)  
*Angelica* species (angelica)  
Oenanthe sarmentosa (water parsley)  
Heracleum lanatum (cow parsnip)  
*Glyceria grandis*, *G. elata* (manna grass)  
Juncus acuminatus (tapertip rush)

*Juncus ensifolius* (daggerleaf rush)

*Juncus bufonius* (toad rush)

*Mimulus guttatus* (common monkey flower)

**Scrub-shrub zone**

*Salix lucida*, *S. rigida*, *S. sitchensis*, *S. scouleriana*, *S. pedicellaris*  
(willow)

*Lysichiton americanus* (skunk cabbage)

*Athyrium filix-femina* (lady fern)

*Cornus sericea* (redstem dogwood)

*Rubus spectabilis* (salmonberry)

*Physocarpus capitatus* (ninebark)

*Ribes species* (gooseberry)

*Rhamnus purshiana* (cascara)

*Sambucus racemosa* (red elderberry) (occurs in wetland-upland transition)

*Lonicera involucrata* (black twinberry)

*Oemleria cerasiformis* (Indian plum)

*Stachys cooleyae* (Stachy's horsemint)

*Prunus emarginata* (bitter cherry)

**Forested zone:**

*Populus balsamifera*, ssp. *trichocarpa* (black cottonwood)

*Fraxinus latifolia* (Oregon ash)

*Thuja plicata* (western red cedar)

*Picea sitchensis* (Sitka spruce)

*Alnus rubra* (red alder)

*Tsuga heterophylla* (hemlock)

*Acer circinatum* (vine maple)

*Maianthemum dilatatum* (wild lily-of-the-valley)

*Ivzula parviflora* (small-flower wood rush)

*Torreyochloa pauciflora* (weak alkaligrass)

*Ribes species* (currants)

**Bog:**

*Sphagnum* species (sphagnum mosses)  
*Rhododendron groenlandicum* (Labrador tea)  
*Vaccinium oxycoccos* (bog cranberry)  
*Kalmia microphylla*, ssp. *occidentalis* (bog laurel)

**Exotic plants that should not be introduced to existing, created, or constructed Puget Sound Basin freshwater wetlands**

*Hedera helix* (English ivy)  
*Phalaris arundinacea* (reed canarygrass)  
*Lythrum salicaria* (purple loosestrife)  
*Iris pseudacorus* (yellow iris)  
*Ilex aquifolia* (holly)  
*Impatiens glandulifera* (policeman's helmet)  
*Lotus corniculatus* (birdsfoot trefoil)  
*Lysimachia thyrsoiflora* (tufted loosestrife)  
*Myriophyllum* species (water milfoil, parrot's feather)  
*Polygonum cuspidatum* (Japanese knotweed)  
*Polygonum sachalinense* (giant knotweed)  
*Rubus discolor* (Himalayan blackberry)  
*Tanacetum vulgare* (common tansy)

**Native plants that should not be introduced to existing, created, or constructed Puget Sound Basin freshwater wetlands**

*Potentilla palustris* (Pacific silverweed)  
*Solarum dulcimara* (bittersweet nightshade)  
*Juncus effusus* (soft rush)  
*Conium maculatum* (poison hemlock)  
*Ranunculus repens* (creeping buttercup)



## Wetlands Guidance Appendix 4: Comparison of Water Chemistry Characteristics In *Sphagnum* Bog And Fen Versus More Typical Wetlands

Water Quality Variable	Typical Wetlands	<i>Sphagnum</i> Bogs and Fens
PH	6 - 7	3.5 - 4.5
Dissolved oxygen (mg/L)	4 - 8	Shallow surface layer oxygenated, anoxic below
Cations	Divalent Ca, Mg common	Divalent Ca, Mg uncommon; Univalent Na, K predominant
Anions	HCO <sub>3</sub> <sup>-</sup> , CO <sub>3</sub> <sup>2-</sup> predominant	Cl <sup>-</sup> , SO <sub>4</sub> <sup>2-</sup> predominant; almost no HCO <sub>3</sub> <sup>-</sup> , CO <sub>3</sub> <sup>2-</sup> (organic acids form buffering system)
Hardness	Moderate	Very low
Total phosphorus (µg/L)	50 - 500	5 - 50
Total Kjeldahl nitrogen (µg/L)	500 - 1000	~ 50

## Wetland Protection Guidelines References

- Chin, N. T. 1996. Watershed Urbanization Effects on Palustrine Wetlands: A Study of the Hydrologic, Vegetative, and Amphibian Community Response over Eight Years. M. S. C. E. Thesis, University of Washington, Seattle, WA.
- Clymo, R. S. 1963. Ion exchange in *Sphagnum* and its relation to bog ecology. *Annals of Botany* 27 (106):310-324.
- Cooke, S. S., Puget Sound Wetlands and Stormwater Management Research Program, unpublished Queen's Bog data.
- Horner, R. R. 1989. Long-term effects of urban runoff on wetlands. Pp. in L. A. Roesner, B. Urbonas, and M. B. Sonnen (eds.), *Design of Urban Runoff Controls*, American Society of Civil Engineers, New York, NY.
- Horner, R. R., J. J. Skupien, E. H. Livingston, and H. E. Shaver. 1994. *Fundamentals of Urban Runoff Management: Technical and Institutional Issues*. Terrene Institute, Washington, D. C.
- Horner, R. R., S. S. Cooke, K. O. Richter, A. L. Azous, L. E. Reinelt, B. L. Taylor, K. A. Ludwa, and M. Valentine. 1996. *Wetlands and Urbanization, Implications for the Future*. Puget Sound Wetlands and Stormwater Management Research Program, Engineering Professional Programs, University of Washington, Seattle, WA.
- Meyer, J., L. Vogel, and T. Duebendorfer, East Lake Sammamish wetland no. 21 unpublished data, submitted to L. Kulzer, King County Surface Water Management Division.
- Moore, P. D. and D. J. Bellamy. 1974. Chapter 3, The Geochemical template. *Peatlands*. Elek Science, London, U. K.
- Thurman, E. M. 1985. *Organic Geochemistry of Natural Waters*. Martinus Nijhoff/Dr W. Junk Publishers, Dordrecht, The Netherlands.
- Vitt, D. H., D. G. Horton, N. G. Slack, and N. Malmer. 1990. *Sphagnum*-dominated peatlands of the hyperoceanic British Columbia coast: Patterns in surface water chemistry and vegetation. *Canadian Journal of Forest Research* 20:696-711.

# **Appendix I-E**

## **Submittal Requirements Checklist**

---

*The Submittal Requirements Checklist is intended to aid the design engineer in preparing a Stormwater Site Plan, previously known as a drainage report. All items included in the following checklist should be addressed as part of any storm water site plan. The City recommends the design engineer follow the order and structure of the checklist to facilitate review, which in turn will expedite permit issuance.*

### **CHAPTER 1 – PROJECT OVERVIEW**

*The project overview is intended to be a summary of detailed information contained in the body of the Stormwater Site Plan. The purpose of Chapter 1 is to provide the reviewer a quick understanding of the project, so that project review can be facilitated. The following elements will be provided in a complete Project Overview Chapter.*

- \_\_\_ Identify type of permit requested.
- \_\_\_ Identify other permits required (e.g. hydraulic permits, Army Corps 404 permits, wetlands, etc.).
- \_\_\_ Identify project location (including address, legal description, parcel number).
- \_\_\_ Include applicable flowcharts for determining minimum requirements (Fig 3.2 or 3.3, Volume 1) with decision path clearly marked.
- \_\_\_ List the minimum requirements that apply to the project.
  
- \_\_\_ Brief description of project to include the following:
  - \_\_\_ Current and proposed condition/land-use
  - \_\_\_ Size of parcel
  - \_\_\_ Acreage developed, redeveloped, replaced or converted by the project
  - \_\_\_ Current assessed value and cost of proposed improvements (for redevelopment projects)
  - \_\_\_ Watershed
  - \_\_\_ Proposed flow control improvements
  - \_\_\_ Proposed runoff treatment improvements
  - \_\_\_ Proposed conveyance improvements
  - \_\_\_ Proposed discharge location and improvements
  - \_\_\_ Downstream condition, impacts and problems
  - \_\_\_ Reference appropriate Sections/Chapters/Appendices of the document for detailed descriptions.
  
- \_\_\_ Vicinity map to include the following:
  - \_\_\_ Locate project site
  - \_\_\_ Identify all roads bordering the site
  - \_\_\_ Identify significant natural and man-made features, and sensitive/critical areas (streams, wetlands, lakes, steep slopes, etc.) in the vicinity of the project.

## CHAPTER 2 – EXISTING CONDITION SUMMARY

*The Existing Condition Summary is intended to provide a complete understanding of the project site and must be based on thorough site research and investigation. Section 4.1.1, Volume 1 describes the contents of the Existing Condition Summary. In addition, a list of elements to be included is provided as follows.*

- \_\_\_ Describe, discuss and identify the following for the project site:
  - \_\_\_ Topography
  - \_\_\_ Land use and ground cover
  - \_\_\_ Natural and man-made drainage patterns
  - \_\_\_ Points of entry and exit for existing drainage to and from the site
  - \_\_\_ Any known historical drainage problems such as flooding, erosion, etc.
  - \_\_\_ Existing utilities (Storm, Water, Sewer)
  - \_\_\_ Areas with high potential for erosion and sediment deposition
  - \_\_\_ Locations of sensitive and critical areas (i.e. vegetative buffers, wetlands, steep slopes, floodplains, geologic hazard areas, streams, creeks, ponds, ravines, springs etc.)
  - \_\_\_ Existing fuel tanks
  - \_\_\_ Groundwater wells on-site and within 100 feet of site.
  
- \_\_\_ Identify difficult site conditions.
- \_\_\_ State whether the project is located in an aquifer recharge area or wellhead protection area as defined by the Tacoma-Pierce County Health Department, the Environmental Protection Agency or by the City.
- \_\_\_ Identify any Superfund areas in the vicinity, and state whether they are tributary to, or receive drainage from, the project site.
- \_\_\_ Identify any specific requirements included in a basin plan for the area.
- \_\_\_ Include references to relevant reports such as basin plans, flood studies, groundwater studies, wetland designations, sensitive area designations, environmental impact statements, environmental checklists, lake restoration plans, water quality reports, etc. Where such reports impose additional conditions on the Proponent, state these conditions and describe any proposed mitigation measures.
  
- \_\_\_ Site Map to include the following:
  - \_\_\_ Topography
  - \_\_\_ Critical areas (i.e. wetlands, steep slopes)
  - \_\_\_ Ground cover
  - \_\_\_ Land use including adjacent properties
  - \_\_\_ Existing development
  - \_\_\_ Existing stormwater facilities including adjacent properties
  - \_\_\_ Wells
  - \_\_\_ Septic systems
  - \_\_\_ Fuel tanks
  - \_\_\_ Floodplains
  - \_\_\_ Scale
  - \_\_\_ North arrow

- \_\_\_ A soil report to identify the following:
  - \_\_\_ Soil types
  - \_\_\_ Hydrologic soil group classification
  - \_\_\_ Groundwater elevation
  - \_\_\_ Presence of perched aquifers, aquitards and confined aquifers
  - \_\_\_ Location of test pits
  - \_\_\_ Infiltration rates determined per the requirements of Volume 3 (where applicable)
  - \_\_\_ Discussion of critical areas or geologic hazards where present.

- \_\_\_ Soil reports will be contained in Appendix A of the report or as a separate document.
- \_\_\_ Identify wells and septic systems “of record” and others, on site and on adjacent property within 100 feet of the project site boundary.
- \_\_\_ Identify fuel tanks, in-use or abandoned on the project site.
- \_\_\_ Describe the 100-year flood hazard zone.

### **CHAPTER 3 – OFF-SITE ANALYSIS**

*The City requires a qualitative discussion of the off-site upstream and downstream system for all projects. Where 10,000 square feet or more of new impervious surface is added and flow control is not provided, a quantitative analysis is also required. Detailed calculations will be contained in Appendix B of the report. Section 4.1.3, Volume 1 describes the contents of the Off-site Analysis in detail. In addition, a list of elements to be included is provided as follows.*

#### Qualitative Analysis

- \_\_\_ Define and map the study area. Map will include the following:
  - \_\_\_ Property lines
  - \_\_\_ Topography
  - \_\_\_ Site boundaries
  - \_\_\_ Study area boundaries
  - \_\_\_ ¼ mile downstream flowpath
  - \_\_\_ Drainage patterns
  - \_\_\_ Potential and existing problems
  - \_\_\_ Land use
  - \_\_\_ Acreage
- \_\_\_ Review all available plans, studies, maps pertaining to the off-site study area.
- \_\_\_ Investigate the drainage system ¼ mile downstream from the project by site visit including the following items:
  - \_\_\_ Problems reported or observed during the resource review
  - \_\_\_ Existing/potential constrictions or capacity deficiencies in the drainage system
  - \_\_\_ Existing/potential flooding problems
  - \_\_\_ Existing/potential overtopping, scouring, bank sloughing, or sedimentation
  - \_\_\_ Significant destruction of aquatic habitat (e.g., siltation, stream incision)
  - \_\_\_ Existing public and private easements through the project site and their corresponding widths
  - \_\_\_ Collect qualitative data on features such as land use, impervious surface, topography, soils, presence of streams, wetlands
  - \_\_\_ Collect information on pipe sizes, channel characteristics, drainage structures

- \_\_\_ Verify tributary drainage areas
- \_\_\_ Note date and weather at time of inspection
- \_\_\_ Describe the drainage system, and its existing and predicted problems through observations, reports, and hydraulic modeling (as necessary) of the City specified design storm event described in Chapter 4 of Volume III. Describe all existing or potential problems as listed above (e.g., ponding water, erosion). The following information should be provided for each existing or potential problem:
  - \_\_\_ Magnitude of or damage caused by the problem
  - \_\_\_ General frequency and duration
  - \_\_\_ Return frequency of storm or flow when the problem occurs (may require quantitative analysis)
  - \_\_\_ Water elevation when the problem occurs
  - \_\_\_ Names and concerns of parties involved
  - \_\_\_ Current mitigation of the problem
  - \_\_\_ Possible cause of the problem
  - \_\_\_ Whether the project is likely to aggravate the problem or create a new one.
- \_\_\_ Properly include off-site areas in drainage calculations.

#### Quantitative Analysis

- \_\_\_ Clearly describe tailwater assumptions
- \_\_\_ Summarize results in text
- \_\_\_ Include calculations in Appendix B of the report
- \_\_\_ Discuss potential fixes for capacity problems
- \_\_\_ Provide profiles where appropriate

### **CHAPTER 4 – PERMANENT STORMWATER CONTROL PLAN**

*Chapter 4 will contain the information used to select, size and locate permanent stormwater control BMPs for the project site. This chapter must present all supporting information, data and calculations in an organized fashion for project reviewers. The chapter will be organized into six sections as follows, with detailed calculations contained in Appendix C.*

#### 1. Pre-Developed Site Hydrology

- \_\_\_ Provide a list of assumptions and site parameters for the pre-developed condition.
- \_\_\_ Identify all sub-basins within, or flowing through, the site. Use consistent labeling for all sub-basins throughout figures, calculations and text.
- \_\_\_ For each subbasin identify current land use, acreage, hydrologic soil group and land use to be modeled under pre-developed conditions. The format used in Example Table 1 shown below is recommended.
- \_\_\_ Provide justification for land uses other than forest.
- \_\_\_ Summarize output data from the pre-developed condition. Example Table 2a or 2b are recommended formats.
- \_\_\_ Include completed [Hydraulic Analysis Worksheet](#) (See Volume I, Appendix I-G) and hydrologic calculations in Appendix C of the report.

\_\_\_\_ Topographic map showing the following under natural (or historic) conditions:

- \_\_\_\_ Sub-basin boundaries
- \_\_\_\_ Off-site contributing areas
- \_\_\_\_ Acreage
- \_\_\_\_ Time of concentration
- \_\_\_\_ Land use
- \_\_\_\_ Natural streams and drainage features
- \_\_\_\_ Locate points of discharge from the site
- \_\_\_\_ Existing on and off-site drainage facilities

**Example Table 1**

Sub-Basin ID	Land Use and Cover condition	Acreage	Soil Group	Modeled as: (List CN)	Comments

**Example Table 2a**

Pre-Developed Condition Event Output: SBUH			
	Peak Flow (cfs)	Volume (ac-ft)	Area (ac)
Basin ID: _____			
2 yr existing			
10 yr existing			
25 yr existing			
100 yr existing			

**Example Table 2b**

Pre-Developed Condition Event Output: WWHM		
	Peak Flow (cfs)	Area (ac)
Basin ID: _____		
2 yr existing		
10 yr existing		
25 yr existing		
100 yr existing		

2. Developed Site Hydrology

- \_\_\_ Provide a list of assumptions and site parameters for the developed condition.
- \_\_\_ Identify all sub-basins within, or flowing through, the site. Use consistent labeling for all sub-basins throughout figures, calculations and text.
- \_\_\_ For each subbasin, identify proposed land use, acreage, hydrologic soil group and land use to be modeled under developed conditions. The format used in Example Table 3 shown below is recommended.
- \_\_\_ Summarize output data from developed condition. Example Table 4a or 4b are recommended formats.
- \_\_\_ Include completed [Hydraulic Analysis Worksheet](#) (See Volume I, Appendix I-G) and hydrologic calculations in Appendix C of the report.
  
- \_\_\_ Topographic map showing the following under proposed conditions:
  - \_\_\_ Sub-basin boundaries
  - \_\_\_ Off-site contributing areas
  - \_\_\_ Acreage
  - \_\_\_ Time of concentration
  - \_\_\_ Land use
  - \_\_\_ Natural streams and drainage features
  - \_\_\_ Locate points of discharge from site
  - \_\_\_ Existing on and off-site drainage facilities

**Example Table 3**

Sub-Basin ID	Land Use and Cover condition	Acreage	Soil Group	Modeled as: (List CN)	Comments

**Example Table 4a**

Developed Condition Event Output: SBUH			
	Peak Flow (cfs)	Volume (ac-ft)	Area (ac)
Basin ID: _____			
- 2 yr existing			
- 10 yr existing			
- 25 yr existing			
- 100 yr existing			



**Example Table 4b**

Developed Condition Event Output: WWHM		
	Peak Flow (cfs)	Area (ac)
Basin ID: _____		
2 yr existing		
10 yr existing		
25 yr existing		
100 yr existing		

3. Performance Standards and Goals

\_\_\_\_\_ Indicate total acreage of impervious surfaces, pollution-generating impervious surfaces and pollution generating pervious surfaces for each Threshold Discharge Area (TDA). Example Table 5 illustrates a recommended format.

\_\_\_\_\_ Include applicable decision chart (See Manual - Table 3.1) with treatment requirements clearly marked and supported.

\_\_\_\_\_ Include applicable decision chart (See Manual -Table 3.2) with flow control requirements clearly marked and supported. If flow control facilities are required, indicate that they are.

\_\_\_\_\_ Include applicable flow chart (See Manual -Figure 3-4) with decision path clearly marked.

\_\_\_\_\_ State conclusions from decision and flow charts.

**Example Table 5**

	Threshold Discharge Area ID
Total Pollution Generating Pervious Surface (PGPS)	_____ ac
Total Pollution Generating Impervious Surface (PGIS)	_____ ac
Native vegetation converted to lawn/landscape	_____ ac
Total Effective Impervious Surface	_____ ac
Increase in 100-year storm peak (cfs)	_____ cfs

#### 4. Flow Control System (where required)

- \_\_\_ Identify sizing method used.
- \_\_\_ Summarize model results.
- \_\_\_ Describe proposed flow control system and appurtenances, including size, type and characteristics of storage facility and control structure.
  
- \_\_\_ Provide a drawing of the flow control facility and its appurtenances, including:
  - \_\_\_ Dimensions,
  - \_\_\_ Orifice/restrictor sizes and elevations,
  - \_\_\_ Control structure location, and
  - \_\_\_ Location of the facility on the project site.
  
- \_\_\_ [Hydraulic Analysis Worksheet, c](#)Calculations, computer printouts (including stage storage tables) for the flow control system to be included in Appendix C of the report.

#### 5. Water Quality System (where required)

- \_\_\_ Include Fig 2.1 (See Manual - Volume V) with the decision flow path clearly marked.
- \_\_\_ Identify the sizing method used.
- \_\_\_ Summarize model results.
- \_\_\_ Identify treatment methods used, including size, type and characteristics of treatment facility and appurtenances.
- \_\_\_ If phosphorus control, enhanced treatment, infiltration and/or oil removal are not used, justify elimination from project site runoff treatment.
  
- \_\_\_ Provide a drawing of the treatment facility and its appurtenances, including:
  - \_\_\_ Dimensions,
  - \_\_\_ Inlet/outlet sizes and elevations,
  - \_\_\_ Location of the facility on the project site, and
  - \_\_\_ Appurtenances/fittings.
  
- \_\_\_ Calculations for the water quality design storm and facility sizing calculations will be included in Appendix D of the report.
- \_\_\_ Where appropriate, include manufacturer's specifications in Appendix D of the report.

#### 6. Conveyance System Analysis and Design

- \_\_\_ Illustrate the proposed conveyance system on a project site plan.
- \_\_\_ Identify pipe sizes, types and slopes.
- \_\_\_ Describe capacities, design flows and velocities for each reach.
- \_\_\_ Include conveyance calculations in Appendix E of the report.

## **CHAPTER 5 – DISCUSSION OF MINIMUM REQUIREMENTS**

*Chapter 5 is intended as a checklist for the applicant and reviewer to verify that the applicable Minimum Requirements have been met within the project submittal. The applicant will list the Minimum Requirements for the project as determined in Chapter 1 and indicate how each is met and where in the submittal, documentation can be found.*

- \_\_\_\_\_ List the Minimum Requirements that apply to the project.
- \_\_\_\_\_ Discuss how the project satisfies each minimum requirement.
- \_\_\_\_\_ Indicate where in the project documentation, each minimum requirement is satisfied.

## **CHAPTER 6 – OPERATION AND MAINTENANCE MANUAL**

*The Operation and Maintenance Manual may be included in the Stormwater Site Plan, however it should be written with the intention of becoming a stand-alone document for the project owner once the project is complete. The owner must use the Operation and Maintenance Manual throughout the life of the system to ensure proper flow control and/or runoff treatment.*

- \_\_\_\_\_ Identify where the Operation and Maintenance Manual is to be kept and that it must be made available to the City for inspection.
- \_\_\_\_\_ Describe each flow control and treatment facility, including what it does and how it works.
- \_\_\_\_\_ Identify and describe maintenance tasks and the frequency of each task for each flow control and treatment facility.
- \_\_\_\_\_ Include a sample maintenance activity log indicating emergency and routine actions taken.

# Appendix I-F

## Bond Quantities Worksheet

---

**SITE IMPROVEMENT BOND QUANTITY WORKSHEET**

<b>Item</b>	<b>Quantity</b>	<b>Unit</b>	<b>Unit Price</b>	<b>Amount</b>
<b>EROSION/SEDIMENT CONTROL</b>				
Backfill & compaction-embankment		CY		
Check dams, 4" minus rock		Each		
Crushed surfacing 1-1/4" minus		CY		
Ditching		CY		
Excavation-bulk		CY		
Fence, silt		LF		
Fence, Temporary (NGPE)		LF		
Hydroseeding		SY		
Jute Mesh		SY		
Mulch, by hand, straw, 3" deep		SY		
Mulch, by machine, straw, 2" deep		SY		
Piping, temporary, CPP, 6"		LF		
Piping, temporary, CPP, 8"		LF		
Piping, temporary, CPP, 12"		LF		
Plastic covering, 6mm thick, sandbagged		SY		
Rip Rap, machine placed; slopes		CY		
Rock Construction Entrance, 50'x15'x1'		Each		
Rock Construction Entrance, 100'x15'x1'		Each		
Sediment pond riser assembly		Each		
Sediment trap, 5' high berm		LF		
Sed. Trap, 5' high, raprapped spillway berm section		LF		
Seeding, by hand		SY		
Sodding, 1" deep, level ground		SY		
Sodding, 1" deep, sloped ground		SY		
TESC Supervisor		HR		
Water truck, dust control		HR		
<b>GENERAL ITEMS</b>				
Backfill & Compaction-embankment		CY		
Backfill & Compaction-trench		CY		
Clear/Remove Brush, by hand		SY		
Clearing/Grubbing/Tree Removal		Acre		
Excavation-bulk		CY		
Excavation-trench		CY		
Fencing, cedar, 6' high		LF		
Fencing, chain link, gate, vinyl coated, 6' high		LF		
Fencing, chain link, gate, vinyl coated, 20'		Each		
Fencing, split rail, 3' high		LF		

**SITE IMPROVEMENT BOND QUANTITY WORKSHEET**

<b>Item</b>	<b>Quantity</b>	<b>Unit</b>	<b>Unit Price</b>	<b>Amount</b>
Fill & compact - common borrow		CY		
Fill & compact - gravel base		CY		
Fill & compact - screened topsoil		CY		
Gabion, 12" deep, stone-filled mesh		SY		
Gabion, 18" deep, stone-filled mesh		SY		
Gabion, 36" deep, stone-filled mesh		SY		
Grading, fine, by hand		SY		
Grading, fine, with grader		SY		
Monuments, 3' long		Each		
Sensitive Areas Sign		Each		
Sodding, 1" deep, sloped ground		SY		
Surveying, line & grade		Day		
Surveying, lot location/lines		Acre		
Traffic control crew (2 flaggers)		HR		
Trail, 4" chipped wood		SY		
Trail, 4" crushed cinder		SY		
Trail, 4" top course		SY		
Wall, retaining concrete		SF		
Wall, rockery		SF		
<b><u>ROAD IMPROVEMENT</u></b>				
AC Grinding, 4' wide machine <1000sy		SY		
AC Grinding, 4' wide machine 1000-2000sy		SY		
AC Grinding, 4' wide machine >2000sy		SY		
AC Removal/Disposal/Repair		SY		
Barricade, type I		LF		
Barricade, type III (Permanent)		LF		
Curb and Gutter, rolled		LF		
Curb and Gutter, vertical		LF		
Curb and Gutter, demolition and disposal		LF		
Curb, extruded asphalt		LF		
Curb, extruded concrete		LF		
Sawcut, asphalt, 3" depth		LF		
Sawcut, concrete, per 1" depth		LF		
Sealant, asphalt		LF		
Shoulder, AC, (see AC road unit price)		SY		
Shoulder, gravel, 4" thick		SY		
Sidewalk, 4" thick		SY		
Sidewalk, 4" thick, demolition and disposal		SY		
Sidewalk, 5" thck		SY		

**SITE IMPROVEMENT BOND QUANTITY WORKSHEET**

<b>Item</b>	<b>Quantity</b>	<b>Unit</b>	<b>Unit Price</b>	<b>Amount</b>
Sidewalk, 5" thick, demolition and disposal		SY		
Sign, handicap		Each		
Striping, per stall		Each		
Striping, thermoplastic, (for crosswalk)		SF		
Striping, 4" reflectorized line		LF		
<b>ROAD SURFACING</b> (4" Rock = 2.5" base & 1.5" top course) For '93 KCRS (6.5" Rock = 5" base & 1.5" top course)				
For KCRS '93, (additional 2.5" base) add:		SY		
AC Overlay, 1.5" AC		SY		
AC Overlay, 2" AC		SY		
AC Road, 2", 4" rock, First 2500 SY		SY		
AC Road, 2", 4" rock, Qty. over 2500 SY		SY		
AC Road, 3", 4" rock, First 2500 SY		SY		
AC Road, 3", 4" rock, Qty. over 2500 SY		SY		
AC Road, 5", First 2500 SY		SY		
AC Road, 5", Qty. over 2500 SY		SY		
AC Road, 6", First 2500 SY		Sy		
AC Road, 6", Qty. over 2500 SY		SY		
Asphalt Treated Base, 4" thick		SY		
Gravel Road, 4" rock, First 2500 SY		SY		
Gravel Road, 4" rock, Qty. over 2500 SY		SY		
PCC Road, 5", no base, over 2500 SY		SY		
PCC Road, 6", no base, over 2500 SY		SY		
Thickened Edge		LF		
<b>DRAINAGE</b> (CPP = Corrugated Plastic Pipe, N12 or equivalent). For Culvert prices, average of 4' cover was assumed. Assume perforated PVC is same price as solid pipe.				
Access Road, R/D		SY		
Bollards - fixed		Each		
Bollards - removable		Each		
*(CBs include frame and lid)				
CB Type I		Each		
CB Type IL		Each		
CB Type II, 48" diameter		Each		
for additional depth over 4'		FT		
CB Type II, 54" diameter		Each		
for additional depth over 4'		FT		
CB Type II, 60" diameter		Each		
for additional depth over 4'		FT		
CB Type II, 72" diameter		Each		
for additional depth over 4'		FT		

**SITE IMPROVEMENT BOND QUANTITY WORKSHEET**

<b>Item</b>	<b>Quantity</b>	<b>Unit</b>	<b>Unit Price</b>	<b>Amount</b>
Through-curb Inlet Framework (Add)		Each		
Cleanout, PVC, 4"		Each		
Cleanout, PVC, 6"		Each		
Cleanout, PVC, 8"		Each		
Culvert, PVC, 4"		LF		
Culvert, PVC, 6"		LF		
Culvert, PVC, 8"		LF		
Culvert, PVC, 12"		LF		
Culvert, CMP, 8"		LF		
Culvert, CMP, 12"		LF		
Culvert, CMP, 15"		LF		
Culvert, CMP, 18"		LF		
Culvert, CMP, 24"		LF		
Culvert, CMP, 30"		LF		
Culvert, CMP, 36"		LF		
Culvert, CMP, 48"		LF		
Culvert, CMP, 60"		LF		
Culvert, CMP, 72"		LF		
Culvert, Concrete, 8"		LF		
Culvert, Concrete, 12"		LF		
Culvert, Concrete, 15"		LF		
Culvert, Concrete, 18"		LF		
Culvert, Concrete, 24"		LF		
Culvert, Concrete, 30"		LF		
Culvert, Concrete, 36"		LF		
Culvert, Concrete, 42"		LF		
Culvert, Concrete, 48"		LF		
Culvert, CPP, 6"		LF		
Culvert, CPP, 8"		LF		
Culvert, CPP, 12"		LF		
Culvert, CPP, 15"		LF		
Culvert, CPP, 18"		LF		
Culvert, CPP, 24"		LF		
Culvert, CPP, 30"		LF		
Culvert, CPP, 36"		LF		
Ditching		CY		
Flow Dispersal Trench (1,436 base+)		LF		
French Drain (3" depth)		LF		



**SITE IMPROVEMENT BOND QUANTITY WORKSHEET**

<b>Item</b>	<b>Quantity</b>	<b>Unit</b>	<b>Unit Price</b>	<b>Amount</b>
Geotextile, laid in trench, polypropylene		SY		
Infiltration pond testing		HR		
Mid-tank Access Riser, 48" dia, 6' deep		Each		
Pond Overflow Spillway		SY		
Restrictor/Oil Separator, 12"		Each		
Restrictor/Oil Separator, 15"		Each		
Restrictor/Oil Separator, 18"		Each		
Riprap, placed		CY		
Tank End Reducer (36" diameter)		Each		
Trash Rack, 12"		Each		
Trash Rack, 15"		Each		
Trash Rack, 18"		Each		
Trash Rack, 21"		Each		

**PARKING LOT SURFACING**

2" AC, 2" top course rock & 4" borrow		SY		
2" AC, 1.5" top course & 2.5" base course		SY		
4" select borrow		SY		
1.5" top course rock & 2.5" base course		SY		

**WRITE-IN ITEMS**


# Appendix I-G

## Hydraulic Analysis Worksheet

---

The following input worksheets are to be used with Western Washington Hydrology Model (WWHM) and SBUH. The applicant is advised to complete the appropriate worksheet and include in the project Stormwater Report for use by the project reviewer.

### WWHM INPUT

Name/Address of development: \_\_\_\_\_

Legal description of development: \_\_\_\_\_

Complete the following tables for subbasins tributary to the project site (on-site and off-site):

#### Pre-Developed Conditions

Subbasin Name	Land Use/ Ground Cover	Outwash (acres)	Till (acres)	Saturated (acres)

#### Developed Conditions

Subbasin Name	Land Use/ Ground Cover	Outwash (acres)	Till (acres)	Saturated (acres)

Describe and justify use of roof runoff credit and/or porous pavement credit:

\_\_\_\_\_

\_\_\_\_\_

\_\_\_\_\_

\_\_\_\_\_

\_\_\_\_\_

\_\_\_\_\_

For the flow control facility, provide the following:

- Bottom length: \_\_\_\_\_
- Bottom width: \_\_\_\_\_
- Sideslopes: \_\_\_\_\_
- Stage/ Storage Table with units: \_\_\_\_\_

For the control structure, provide the following:

- Outlet pipe size: \_\_\_\_\_
- Orifice elevation: \_\_\_\_\_ Diameter: \_\_\_\_\_
- Orifice elevation: \_\_\_\_\_ Diameter: \_\_\_\_\_
- Orifice elevation: \_\_\_\_\_ Diameter: \_\_\_\_\_
- Riser elevation: \_\_\_\_\_ Diameter: \_\_\_\_\_
- V-notch weir data (alternate): \_\_\_\_\_

**SBUH INPUT**

Name/Address of development: \_\_\_\_\_

Legal description of development: \_\_\_\_\_

Rainfall Type: \_\_\_\_\_

Hydraulic Method: \_\_\_\_\_

Hydraulic Interval: \_\_\_\_\_

Peak Factor: \_\_\_\_\_

Tp Factor: \_\_\_\_\_

Complete the following tables for subbasins tributary to the project site (on-site and off-site).

**Pre-Developed Conditions**

Subbasin Name	Acreage	Land Use/ Ground Cover*	Hydrologic Soil Group*	Curve Number

Note: Where more than one land use or soil group are present within a subbasin, a line item must be shown for each to support calculation of the composite pervious and impervious Curve Numbers.

**Developed Conditions**

Subbasin Name	Acreage	Land Use/ Ground Cover*	Hydrologic Soil Group*	Curve Number

Note: Where more than one land use or soil group are present within a subbasin, a line item must be shown for each to support calculation of the composite pervious and impervious Curve Numbers.

Provide pervious and impervious Tc data for each subbasin including the flow path shown on an attached figure.

Describe and justify elimination of roof areas from calculation and/or porous pavement credit:

\_\_\_\_\_

\_\_\_\_\_

\_\_\_\_\_

\_\_\_\_\_

\_\_\_\_\_

\_\_\_\_\_

For the flow control facility, provide the following:

- Bottom length: \_\_\_\_\_
- Bottom width: \_\_\_\_\_
- Sideslopes: \_\_\_\_\_
- Stage/ Storage Table with units: \_\_\_\_\_

For the control structure, provide the following:

- Outlet pipe size: \_\_\_\_\_
- Orifice elevation: \_\_\_\_\_ Diameter: \_\_\_\_\_
- Orifice elevation: \_\_\_\_\_ Diameter: \_\_\_\_\_
- Orifice elevation: \_\_\_\_\_ Diameter: \_\_\_\_\_
- Riser elevation: \_\_\_\_\_ Diameter: \_\_\_\_\_
- V-notch weir data (alternate): \_\_\_\_\_

## References

---

- Azous, A.L. and Horner R.R., "Wetlands and Urbanization, Implications for the Future," Final Report of the Puget Sound Wetlands and Stormwater Management Research Program, 1997.
- Booth, Derek B. and Jackson, C. Rhett, "Urbanization of Aquatic Systems: Degradation Thresholds, Stormwater Detection, and the Limits of Mitigation," *Journal of the American Water Resources Association*, October 1997
- Herrera, 1993 Cost Analysis – Washington Department of Ecology Minimum Requirements for Stormwater Management, Herrera Environmental Consultants/Ecology, 1993
- Hydrosphere Data Products, Inc., CD-ROM Hydrodata, USGS Daily and Peak Values
- Issaquah Creek Basin and Nonpoint Action Plan, King County Surface Water Management Division, Dec. 1996.
- Karr, J.R., "Biological Integrity: A Long-Neglected Aspect of Water Resources Management," *Ecological Applications* 1(1):66-84, 1991.
- Kleindl, W., A Benthic Index of Biotic Integrity for Puget Sound Lowland Streams, Masters Thesis, University of Washington, Seattle, Washington. 68 pp., 1995
- Langbein, W.B., "Annual Floods and the Partial-Duration Flood Series," *Transactions American Geophysical Union*, Vol. 30, pp. 879-881, 1949.
- Lucchetti, G. and Fuerstenberg, R., "Relative Fish Use in Urban and Non-Urban Streams," *Proceedings of the Conference on Wild Salmon*, Vancouver, B.C., 1993.
- May Christopher, et al, "Effects of Urbanization on Small Streams in the Puget Sound Lowland Ecoregion," *Watershed Protection Techniques*, Vol. 2, No. 4, June 1997.
- Miller, J.F., Frederick, R.H. and Tracey, R.S., NOAA ATLAS 2, Precipitation - Frequency Atlas of the Western United States, Volume IX - Washington, U.S. Dept. of Commerce, NOAA, National Weather Service, Washington, D.C., 1973.
- Perrich, Jerry R., The ESE National Precipitation Databook, Cahners Publishing Co., 1992.
- Puget Sound Water Quality Management Plan, Puget Sound Water Quality Authority, 1987, 1989, 1991, 1994
- Schaefer, M.G., "Regional Analyses of Precipitation Annual Maxima in Washington State," *Water Resources Research*, Vol. 26, No. 1 pp. 119-132, January 1990.
- Schaefer, M.G., Technical Note 3: Design Storm Construction, Dam Safety Guidelines, Washington State Department of Ecology, publication 92-55G, April 1993.
- Strecker, Eric W., et al, Analysis of Oregon Urban Runoff Water Quality Monitoring Data Collected From 1990 to 1996, The Oregon Association of Clean Water Agencies, 1997.
- Tri-County Road Maintenance ESA Technical Working Group, under the Tri-County ESA Response Effort (King, Pierce, Snohomish and other municipalities and entities in Washington State), Regional Road Maintenance Endangered Species Act – Program Guidelines, under final review 2002.



# Glossary and Notations

---

The following terms are provided for reference and use with this manual. They shall be superseded by any other definitions for these terms adopted by ordinance, unless they are defined in a Washington State WAC or RCW, or are used and defined as part of the Minimum Requirements for all new development and redevelopment.

<b>AASHTO classification</b>	The official classification of soil materials and soil aggregate mixtures for highway construction, used by the American Association of State Highway and Transportation Officials.
<b>Absorption</b>	The penetration of a substance into or through another, such as the dissolving of a soluble gas in a liquid.
<b>Adjacent steep slope</b>	A slope with a gradient of 15 percent or steeper within five hundred feet of the site.
<b>Adjustment</b>	A variation in the application of a Minimum Requirement to a particular project. Adjustments provide substantially equivalent environmental protection.
<b>Adsorption</b>	The adhesion of a substance to the surface of a solid or liquid; often used to extract pollutants by causing them to be attached to such adsorbents as activated carbon or silica gel. Hydrophobic, or water-repulsing adsorbents, are used to extract oil from waterways when oil spills occur. Heavy metals such as zinc and lead often adsorb onto sediment particles.
<b>Aeration</b>	The process of being supplied or impregnated with air. In waste treatment, the process used to foster biological and chemical purification. In soils, the process by which air in the soil is replenished by air from the atmosphere. In a well aerated soil, the soil air is similar in composition to the atmosphere above the soil. Poorly aerated soils usually contain a much higher percentage of carbon dioxide and a correspondingly lower percentage of oxygen.
<b>Aerobic</b>	Living or active only in the presence of free (dissolved or molecular) oxygen.
<b>Aerobic bacteria</b>	Bacteria that require the presence of free oxygen for their metabolic processes.
<b>Aggressive plant species</b>	Opportunistic species of inferior biological value that tend to out-compete more desirable forms and become dominant; applied to native species in this manual.

<b>Algae</b>	Primitive plants, many microscopic, containing chlorophyll and forming the base of the food chain in aquatic environments. Some species may create a nuisance when environmental conditions are suitable for prolific growth.
<b>Algal bloom</b>	Proliferation of living algae on the surface of lakes, streams or ponds; often stimulated by phosphate over-enrichment. Algal blooms reduce the oxygen available to other aquatic organisms.
<b>American Public Works Association (APWA)</b>	The Washington State Chapter of the American Public Works Association.
<b>Anadromous</b>	Fish that grow to maturity in the ocean and return to rivers for spawning.
<b>Anaerobic</b>	Living or active in the absence of oxygen.
<b>Anaerobic bacteria</b>	Bacteria that do not require the presence of free or dissolved oxygen for metabolism.
<b>Annual flood</b>	The highest peak discharge on average which can be expected in any given year.
<b>Antecedent moisture conditions</b>	The degree of wetness of a watershed or within the soil at the beginning of a storm.
<b>Anti-seep collar</b>	A device constructed around a pipe or other conduit and placed through a dam, levee, or dike for the purpose of reducing seepage losses and piping failures.
<b>Anti-vortex device</b>	A facility placed at the entrance to a pipe conduit structure such as a drop inlet spillway or hood inlet spillway to prevent air from entering the structure when the pipe is flowing full.
<b>Applicable BMPs</b>	As used in Volume IV, applicable BMPs are those source control BMPs that are expected to be required by local governments at new development and redevelopment sites. Applicable BMPs will also be required if they are incorporated into NPDES permits, or they are included by local governments in a stormwater program for existing facilities.
<b>Applicant</b>	The person who has applied for a development permit or approval.
<b>Appurtenances</b>	Machinery, appliances, or auxiliary structures attached to a main structure, but not considered an integral part thereof, for the purpose of enabling it to function.
<b>Aquifer</b>	A geologic stratum containing ground water that can be withdrawn and used for human purposes.



<b>Arterial</b>	A road or street primarily for through traffic. A major arterial connects an Interstate Highway to cities and counties. A minor arterial connects major arterials to collectors. A collector connects an arterial to a neighborhood. A collector is not an arterial. A local access road connects individual homes to a collector.
<b>As-built drawings</b>	Engineering plans which have been revised to reflect all changes to the plans which occurred during construction.
<b>As-graded</b>	The extent of surface conditions on completion of grading.
<b>BSBL</b>	See Building set back line.
<b>Background</b>	A description of pollutant levels arising from natural sources, and not because of man's immediate activities.
<b>Backwater</b>	Water upstream from an obstruction which is deeper than it would normally be without the obstruction.
<b>Baffle</b>	A device to check, deflect, or regulate flow.
<b>Bankfull discharge</b>	A flow condition where streamflow completely fills the stream channel up to the top of the bank. In undisturbed watersheds, the discharge conditions occur on average every 1.5 to 2 years and controls the shape and form of natural channels.
<b>Base flood</b>	A flood having a one percent chance of being equaled or exceeded in any given year. This is also referred to as the 100-year flood.
<b>Base flood elevation</b>	The water surface elevation of the base flood. It shall be referenced to the National Geodetic Vertical Datum of 1929 (NGVD).
<b>Baseline sample</b>	A sample collected during dry-weather flow (i.e., it does not consist of runoff from a specific precipitation event).
<b>Basin plan</b>	<p>A plan that assesses, evaluates, and proposes solutions to existing and potential future impacts to the beneficial uses of, and the physical, chemical, and biological properties of waters of the state within a basin. Basins typically range in size from 1 to 50 square miles. A plan should include but not be limited to recommendations for:</p> <ul style="list-style-type: none"> <li>• Stormwater requirements for new development and redevelopment;</li> <li>• Capital improvement projects;</li> <li>• Land Use management through identification and protection of critical areas, comprehensive land use and transportation plans, zoning regulations, site development standards, and conservation areas;</li> </ul>

- Source control activities including public education and involvement, and business programs;
- Other targeted stormwater programs and activities, such as maintenance, inspections and enforcement;
- Monitoring; and
- An implementation schedule and funding strategy.

A plan that is “adopted and implemented” must have the following characteristics:

- It must be adopted by legislative or regulatory action of jurisdictions with responsibilities under the plan;
- Ordinances, regulations, programs, and procedures recommended by the plan should be in effect or on schedule to be in effect; and,
- An implementation schedule and funding strategy that are in progress.

**Bearing capacity**

The maximum load that a material can support before failing.

**Bedrock**

The more or less solid rock in place either on or beneath the surface of the earth. It may be soft, medium, or hard and have a smooth or irregular surface.

**Bench**

A relatively level step excavated into earth material on which fill is to be placed.

**Berm**

A constructed barrier of compacted earth, rock, or gravel. In a stormwater facility, a berm may serve as a vertical divider typically built up from the bottom.

**Best management practice (BMP)**

The schedules of activities, prohibitions of practices, maintenance procedures, and structural and/or managerial practices, that when used singly or in combination, prevent or reduce the release of pollutants and other adverse impacts to waters of Washington State.

**Biochemical oxygen demand (BOD)**

An indirect measure of the concentration of biologically degradable materials present in organic wastes. The amount of free oxygen utilized by aerobic organisms when allowed to attack the organic material in an aerobically maintained environment at a specified temperature (20°C) for a specific time period (5 days), and thus stated as BOD5. It is expressed in milligrams of oxygen utilized per liter of liquid waste volume (mg/l) or in milligrams of oxygen per kilogram of waste solution (mg/kg = ppm = parts per million parts). Also called biological oxygen demand.

<b>Biodegradable</b>	Capable of being readily broken down by biological means, especially by microbial action. Microbial action includes the combined effect of bacteria, fungus, flagellates, amoebae, ciliates, and nematodes. Degradation can be rapid or may take many years depending upon such factors as available oxygen and moisture.
<b>Bioengineering</b>	The combination of biological, mechanical, and ecological concepts (and methods) to control erosion and stabilize soil through the use of vegetation or in combination with construction materials.
<b>Biofilter</b>	A designed treatment facility using a combined soil and vegetation system for filtration, infiltration, adsorption, and biological uptake of pollutants in stormwater when runoff flows over and through. Vegetation growing in these facilities acts as both a physical filter which causes gravity settling of particulates by regulating velocity of flow, and also as a biological sink when direct uptake of dissolved pollutants occurs. The former mechanism is probably the most important in western Washington where the period of major runoff coincides with the period of lowest biological activity.
<b>Biofiltration</b>	The process of reducing pollutant concentrations in water by filtering the polluted water through biological materials.
<b>Biological control</b>	A method of controlling pest organisms by means of introduced or naturally occurring predatory organisms, sterilization, the use of inhibiting hormones, or other means, rather than by mechanical or chemical means.
<b>Biological magnification</b>	The increasing concentration of a substance along succeeding steps in a food chain. Also called biomagnification.
<b>Bollard</b>	A post (may or may not be removable) used to prevent vehicular access.
<b>Bond</b>	A surety bond, cash deposit or escrow account, assignment of savings, irrevocable letter of credit or other means acceptable to or required by the manager to guarantee that work is completed in compliance with the project's drainage plan and in compliance with all local government requirements.
<b>Borrow area</b>	A source of earth fill material used in the construction of embankments or other earth fill structures.
<b>Buffer</b>	The zone contiguous with a sensitive area that is required for the continued maintenance, function, and structural stability of the sensitive area. The critical functions of a riparian buffer (those associated with an aquatic system) include shading, input of organic debris and coarse sediments, uptake of nutrients, stabilization of banks, interception of fine sediments, overflow during high water events, protection from disturbance by humans and domestic animals,

maintenance of wildlife habitat, and room for variation of aquatic system boundaries over time due to hydrologic or climatic effects. The critical functions of terrestrial buffers include protection of slope stability, attenuation of surface water flows from stormwater runoff and precipitation, and erosion control.

<b>Building setback line (BSBL)</b>	A line measured parallel to a property, easement, drainage facility, or buffer boundary, that delineates the area (defined by the distance of separation) where buildings or other obstructions are prohibited (including decks, patios, outbuildings, or overhangs beyond 18 inches). Wooden or chain link fences and landscaping are allowable within a building setback line. In this manual the minimum building setback line shall be 5 feet.
<b>CIP</b>	See Capital Improvement Project.
<b>Capital Improvement Project or Program (CIP)</b>	A project prioritized and scheduled as a part of an overall construction program or, the actual construction program.
<b>Catch basin</b>	A chamber or well, usually built at the curb line of a street, for the admission of surface water to a sewer or subdrain, having at its base a sediment sump designed to retain grit and detritus below the point of overflow.
<b>Catchline</b>	The point where a severe slope intercepts a different, more gentle slope.
<b>Catchment</b>	Surface drainage area.
<b>Cation Exchange Capacity (CEC)</b>	The amount of exchangeable cations that a soil can adsorb at pH 7.0.
<b>CESCL</b>	See Contractor Erosion and Spill Control Lead
<b>Channel</b>	A feature that conveys surface water and is open to the air.
<b>Channel, constructed</b>	Channels or ditches constructed (or reconstructed natural channels) to convey surface water.
<b>Channel, natural</b>	Streams, creeks, or swales that convey surface/ground water and have existed long enough to establish a stable route and/or biological community.
<b>Channel stabilization</b>	Erosion prevention and stabilization of velocity distribution in a channel using vegetation, jetties, drops, revetments, and/or other measures.
<b>Channel storage</b>	Water temporarily stored in channels while enroute to an outlet.

<b>Channelization</b>	Alteration of a stream channel by widening, deepening, straightening, cleaning, or paving certain areas to change flow characteristics.
<b>Check dam</b>	Small dam constructed in a gully or other small watercourse to decrease the streamflow velocity, minimize channel scour, and promote deposition of sediment.
<b>Chemical oxygen demand (COD)</b>	A measure of the amount of oxygen required to oxidize organic and oxidizable inorganic compounds in water. The COD test, like the BOD test, is used to determine the degree of pollution in water.
<b>Civil engineer</b>	A professional engineer licensed in the State of Washington in Civil Engineering.
<b>Civil engineering</b>	The application of the knowledge of the forces of nature, principles of mechanics and the properties of materials to the evaluation, design and construction of civil works for the beneficial uses of mankind.
<b>Clay lens</b>	A naturally occurring, localized area of clay which acts as an impermeable layer to runoff infiltration.
<b>Clearing</b>	The destruction and removal of vegetation by manual, mechanical, or chemical methods.
<b>Closed depression</b>	An area which is low-lying and either has no, or such a limited, surface water outlet that during storm events the area acts as a retention basin.
<b>Cohesion</b>	The capacity of a soil to resist shearing stress, exclusive of functional resistance.
<b>Coliform bacteria</b>	Microorganisms common in the intestinal tracts of man and other warm-blooded animals; all the aerobic and facultative anaerobic, gram-negative, nonspore-forming, rod-shaped bacteria which ferment lactose with gas formation within 48 hours at 35°C. Used as an indicator of bacterial pollution.
<b>Commercial agriculture</b>	Those activities conducted on lands defined in RCW 84.34.020(2), and activities involved in the production of crops or livestock for wholesale trade. An activity ceases to be considered commercial agriculture when the area on which it is conducted is proposed for conversion to a nonagricultural use or has lain idle for more than five (5) years, unless the idle land is registered in a federal or state soils conservation program, or unless the activity is maintenance of irrigation ditches, laterals, canals, or drainage ditches related to an existing and ongoing agricultural activity.
<b>Compaction</b>	The densification, settlement, or packing of soil in such a way that permeability of the soil is reduced. Compaction effectively shifts the performance of a hydrologic group to a lower permeability hydrologic group. For example, a group B hydrologic soil can be compacted and

be effectively converted to a group C hydrologic soil in the way it performs in regard to runoff.

Compaction may also refer to the densification of a fill by mechanical means.

**Compensatory storage** New excavated storage volume equivalent to the flood storage capacity eliminated by filling or grading within the flood fringe. Equivalent shall mean that the storage removed shall be replaced by equal volume between corresponding one-foot contour intervals that are hydraulically connected to the floodway through their entire depth.

**Compost** Organic residue or a mixture of organic residues and soil, that has undergone biological decomposition until it has become relatively stable humus.

Reference note: The Department of Ecology Interim Guidelines for Compost Quality (1994) defines compost as “the product of composting; it has undergone an initial, rapid stage of decomposition and is in the process of humification (curing).” Compost used should meet specifications for grade A or AA compost in Ecology publication 94-038.

**Composted Mulch** Mulch prepared from decomposed organic materials that have undergone a controlled process to minimize weed seeds. Acceptable feedstocks include, but are not limited to, yard debris, wood waste, land clearing debris, brush, and branches.

**Composting** A controlled process of degrading organic matter by microorganisms. Present day composting is the aerobic, thermophilic decomposing of organic waste to relatively stable humus. Composting is the process of making usable, organic matter that is beneficial to plants and has converted nutrients into slow-release forms (versus mineralized water-soluble forms found in fertilizer).

**Comprehensive planning** Planning that takes into account all aspects of water, air, and land resources and their uses and limits.

**Conservation district** A public organization created under state enabling law as a special-purpose district to develop and carry out a program of soil, water, and related resource conservation, use, and development within its boundaries, usually a subdivision of state government with a local governing body and always with limited authority. Often called a soil conservation district or a soil and water conservation district.

**Constructed wetland** Those wetlands intentionally created on sites that are not wetlands for the primary purpose of wastewater or stormwater treatment and managed as such. Constructed wetlands are normally considered as part of the stormwater collection and treatment system.

<b>Contour</b>	An imaginary line on the surface of the earth connecting points of the same elevation.
<b>Contractor Erosion and Spill Control Lead (CESCL)</b>	The employee designated as the responsible representative in charge of erosion and spill control. The CESCL shall have a current certificate in construction site erosion and sediment control from Associated General Contractors – Education Foundation or approved equivalent.
<b>Conveyance</b>	A mechanism for transporting water from one point to another, including pipes, ditches, and channels.
<b>Conveyance system</b>	The drainage facilities, both natural and man-made, which collect, contain, and provide for the flow of surface and stormwater from the highest points on the land down to a receiving water. The natural elements of the conveyance system include swales and small drainage courses, streams, rivers, lakes, and wetlands. The human-made elements of the conveyance system include gutters, ditches, pipes, channels, and most retention/detention facilities.
<b>Cover crop</b>	A close-growing crop grown primarily for the purpose of protecting and improving soil between periods of permanent vegetation.
<b>Created wetland</b>	Means those wetlands intentionally created from nonwetland sites to produce or replace natural wetland habitat (e.g., compensatory mitigation projects).
<b>Critical Areas</b>	At a minimum, areas which include wetlands, areas with a critical recharging effect on aquifers used for potable water, fish and wildlife habitat conservation areas, frequently flooded areas, geologically hazardous areas, including unstable slopes, and associated areas and ecosystems.
<b>Critical Drainage Area</b>	An area with such severe flooding, drainage and/or erosion/sedimentation conditions that the area has been formally adopted as a Critical Drainage Area by rule under the procedures specified in an ordinance.
<b>Critical reach</b>	The point in a receiving stream below a discharge point at which the lowest dissolved oxygen level is reached and stream recovery begins.
<b>Culvert</b>	Pipe or concrete box structure that drains open channels, swales or ditches under a roadway or embankment. Typically with no catchbasins or manholes along its length.
<b>Cut</b>	Portion of land surface or area from which earth has been removed or will be removed by excavating; the depth below original ground surface to excavated surface.
<b>Cut-and-fill</b>	Process of earth moving by excavating part of an area and using the excavated material for adjacent embankments or fill areas.

<b>Cut slope</b>	A slope formed by excavating overlying material to connect the original ground surface with a lower ground surface created by the excavation. A cut slope is distinguished from a bermed slope, which is constructed by importing soil to create the slope.
<b>DNS</b>	See Determination of Nonsignificance.
<b>Dead storage</b>	The volume available in a depression in the ground below any conveyance system, or surface drainage pathway, or outlet invert elevation that could allow the discharge of surface and stormwater runoff.
<b>Dedication of land</b>	Refers to setting aside a portion of a property for a specific use or function.
<b>Degradation</b>	(Biological or chemical) The breakdown of complex organic or other chemical compounds into simpler substances, usually less harmful than the original compound, as with the degradation of a persistent pesticide. (Geological) Wearing down by erosion. (Water) The lowering of the water quality of a watercourse by an increase in the pollutant loading.
<b>Degraded (disturbed) wetland (community)</b>	A wetland (community) in which the vegetation, soils, and/or hydrology have been adversely altered, resulting in lost or reduced functions and values; generally, implies topographic isolation; hydrologic alterations such as hydroperiod alteration (increased or decreased quantity of water), diking, channelization, and/or outlet modification; soils alterations such as presence of fill, soil removal, and/or compaction; accumulation of toxicants in the biotic or abiotic components of the wetland; and/or low plant species richness with dominance by invasive weedy species.
<b>Denitrification</b>	The biochemical reduction of nitrates or nitrites in the soil or organic deposits to ammonia or free nitrogen.
<b>Depression storage</b>	The amount of precipitation that is trapped in depressions on the surface of the ground.
<b>Design engineer</b>	The professional civil engineer licensed in the State of Washington who prepares the analysis, design, and engineering plans for an applicant's permit or approval submittal.
<b>Design storm</b>	A prescribed hyetograph and total precipitation amount (for a specific duration recurrence frequency) used to estimate runoff for a hypothetical storm of interest or concern for the purposes of analyzing existing drainage, designing new drainage facilities or assessing other impacts of a proposed project on the flow of surface water. (A hyetograph is a graph of percentages of total precipitation for a series of time steps representing the total time during which the precipitation occurs.)



<b>Detention</b>	The release of stormwater runoff from the site at a slower rate than it is collected by the stormwater facility system, the difference being held in temporary storage.
<b>Detention facility</b>	An above or below ground facility, such as a pond or tank, that temporarily stores stormwater runoff and subsequently releases it at a slower rate than it is collected by the drainage facility system. There is little or no infiltration of stored stormwater.
<b>Detention time</b>	The theoretical time required to displace the contents of a stormwater treatment facility at a given rate of discharge (volume divided by rate of discharge).
<b>Determination of Nonsignificance (DNS)</b>	The written decision by the responsible official of the lead agency that a proposal is not likely to have a significant adverse environmental impact, and therefore an EIS is not required.
<b>Development</b>	Means new development, redevelopment, or both. See definitions for each.
<b>Discharge</b>	Runoff leaving a new development or redevelopment via overland flow, built conveyance systems, or infiltration facilities. A hydraulic rate of flow, specifically fluid flow; a volume of fluid passing a point per unit of time, commonly expressed as cubic feet per second, cubic meters per second, gallons per minute, gallons per day, or millions of gallons per day.
<b>Dispersion</b>	Release of surface and stormwater runoff from a drainage facility system such that the flow spreads over a wide area and is located so as not to allow flow to concentrate anywhere upstream of a drainage channel with erodible underlying granular soils.
<b>Ditch</b>	A long narrow excavation dug in the earth for drainage with its top width less than 10 feet at design flow.
<b>Divide, Drainage</b>	The boundary between one drainage basin and another.
<b>Drain</b>	A buried pipe or other conduit (closed drain). A ditch (open drain) for carrying off surplus surface water or ground water.
<b>(To) Drain</b>	To provide channels, such as open ditches or closed drains, so that excess water can be removed by surface flow or by internal flow. To lose water (from the soil) by percolation.
<b>Drainage</b>	Refers to the collection, conveyance, containment, and/or discharge of surface and stormwater runoff.
<b>Drainage basin</b>	A geographic and hydrologic subunit of a watershed.

<b>Drainage channel</b>	A drainage pathway with a well-defined bed and banks indicating frequent conveyance of surface and stormwater runoff.
<b>Drainage course</b>	A pathway for watershed drainage characterized by wet soil vegetation; often intermittent in flow.
<b>Drainage easement</b>	A legal encumbrance that is placed against a property's title to reserve specified privileges for the users and beneficiaries of the drainage facilities contained within the boundaries of the easement.
<b>Drainage pathway</b>	The route that surface and stormwater runoff follows downslope as it leaves any part of the site.
<b>Drainage review</b>	An evaluation by Plan Approving Authority staff of a proposed project's compliance with the drainage requirements in this manual or its technical equivalent.
<b>Drainage, Soil</b>	<p>As a natural condition of the soil, soil drainage refers to the frequency and duration of periods when the soil is free of saturation; for example, in well-drained soils the water is removed readily but not rapidly; in poorly drained soils the root zone is waterlogged for long periods unless artificially drained, and the roots of ordinary crop plants cannot get enough oxygen; in excessively drained soils the water is removed so completely that most crop plants suffer from lack of water. Strictly speaking, excessively drained soils are a result of excessive runoff due to steep slopes or low available water-holding capacity due to small amounts of silt and clay in the soil material. The following classes are used to express soil drainage:</p> <p>Well drained - Excess water drains away rapidly and no mottling occurs within 36 inches of the surface.</p> <ul style="list-style-type: none"> <li>• Moderately well drained - Water is removed from the soil somewhat slowly, resulting in small but significant periods of wetness. Mottling occurs between 18 and 36 inches.</li> <li>• Somewhat poorly drained - Water is removed from the soil slowly enough to keep it wet for significant periods but not all of the time. Mottling occurs between 8 and 18 inches.</li> <li>• Poorly drained - Water is removed so slowly that the soil is wet for a large part of the time. Mottling occurs between 0 and 8 inches.</li> <li>• Very poorly drained - Water is removed so slowly that the water table remains at or near the surface for the greater part of the time. There may also be periods of surface ponding. The soil has a black to gray surface layer with mottles up to the surface.</li> </ul>
<b>Drawdown</b>	Lowering of the water surface (in open channel flow), water table or piezometric surface (in ground water flow) resulting from a withdrawal of water.

<b>Drop-inlet spillway</b>	Overall structure in which the water drops through a vertical riser connected to a discharge conduit.
<b>Drop spillway</b>	Overall structure in which the water drops over a vertical wall onto an apron at a lower elevation.
<b>Drop structure</b>	A structure for dropping water to a lower level and dissipating its surplus energy; a fall. A drop may be vertical or inclined.
<b>Dry weather flow</b>	The combination of groundwater seepage and allowed non-stormwater flows found in storm sewers during dry weather.. Also that flow in streams during the dry season.
<b>EIS</b>	See Environmental Impact Statement.
<b>ESC</b>	Erosion and Sediment Control (Plan).
<b>Earth material</b>	Any rock, natural soil or fill and/or any combination thereof. Earth material shall not be considered topsoil used for landscape purposes. Topsoil used for landscaped purposes shall comply with ASTM D 5268 specifications. Engineered soil/landscape systems are also defined independently.
<b>Easement</b>	The legal right to use a parcel of land for a particular purpose. It does not include fee ownership, but may restrict the owners use of the land.
<b>Effective Impervious Surface</b>	Those impervious surfaces that are connected via sheet flow or discrete conveyance to a drainage system. Impervious surfaces on residential development sites are considered ineffective if the runoff is dispersed through at least one hundred feet of native vegetation in accordance with BMP T5.30 - "Full Dispersion," as described in Chapter 5 of Volume V.
<b>Embankment</b>	A structure of earth, gravel, or similar material raised to form a pond bank or foundation for a road.
<b>Emergent plants</b>	Aquatic plants that are rooted in the sediment but whose leaves are at or above the water surface. These wetland plants often have high habitat value for wildlife and waterfowl, and can aid in pollutant uptake.
<b>Emergency spillway</b>	A vegetated earth channel used to safely convey flood discharges in excess of the capacity of the principal spillway.
<b>Emerging technology</b>	Treatment technologies that have not been evaluated with approved protocols, but for which preliminary data indicate that they may provide a necessary function(s) in a stormwater treatment system. Emerging technologies need additional evaluation to define design criteria to achieve, or to contribute to achieving, state performance goals, and to define the limits of their use.

<b>Energy dissipator</b>	Any means by which the total energy of flowing water is reduced. In stormwater design, they are usually mechanisms that reduce velocity prior to, or at, discharge from an outfall in order to prevent erosion. They include rock splash pads, drop manholes, concrete stilling basins or baffles, and check dams.
<b>Energy gradient</b>	The slope of the specific energy line (i.e., the sum of the potential and velocity heads).
<b>Engineered soil/landscape system</b>	<p>This is a self-sustaining soil and plant system that simultaneously supports plant growth, soil microbes, water infiltration, nutrient and pollutant adsorption, sediment and pollutant biofiltration, water interflow, and pollution decomposition. The system shall be protected from compaction and erosion. The system shall be planted and/or mulched as part of the installation.</p> <p>The engineered soil/plant system shall have the following characteristics:</p> <ol style="list-style-type: none"> <li>a. Be protected from compaction and erosion.</li> <li>b. Have a plant system to support a sustained soil quality.</li> <li>c. Possess permeability characteristics of not less than 6.0, 2.0, and 0.6 inches/hour for hydrologic soil groups A, B, and C, respectively (per ASTM D 3385). D is less than 0.6 inches/hour.</li> <li>d. Possess minimum percent organic matter of 12, 14, 16, and 18 percent (dry-weight basis) for hydrologic soil groups A, B, C, and D, respectively (per ASTM D 2974).</li> </ol>
<b>Engineering geology</b>	The application of geologic knowledge and principles in the investigation and evaluation of naturally occurring rock and soil for use in the design of civil works.
<b>Engineering plan</b>	A plan prepared and stamped by a professional civil engineer.
<b>Enhancement</b>	To raise value, desirability, or attractiveness of an environment associated with surface water.
<b>Environmental Impact Statement (EIS)</b>	A document that discusses the likely significant adverse impacts of a proposal, ways to lessen the impacts, and alternatives to the proposal. They are required by the national and state environmental policy acts when projects are determined to have significant environmental impact.
<b>Erodible granular soils</b>	Soil materials that are easily eroded and transported by running water, typically fine or medium grained sand with minor gravel, silt, or clay content. Such soils are commonly described as Everett or Indianola series soil types in the SCS classification. Also included are

any soils showing examples of existing severe stream channel incision as indicated by unvegetated streambanks standing over two feet high above the base of the channel.

## **Erosion**

The wearing away of the land surface by running water, wind, ice, or other geological agents, including such processes as gravitational creep. Also, detachment and movement of soil or rock fragments by water, wind, ice, or gravity. The following terms are used to describe different types of water erosion:

Accelerated erosion - Erosion much more rapid than normal or geologic erosion, primarily as a result of the influence of the activities of man or, in some cases, of the animals or natural catastrophes that expose bare surfaces (e.g., fires).

- Geological erosion - The normal or natural erosion caused by geological processes acting over long geologic periods and resulting in the wearing away of mountains, the building up of floodplains, coastal plains, etc. Synonymous with natural erosion.
- Gully erosion - The erosion process whereby water accumulates in narrow channels and, over short periods, removes the soil from this narrow area to considerable depths, ranging from 1 to 2 feet to as much as 75 to 100 feet.
- Natural erosion - Wearing away of the earth's surface by water, ice, or other natural agents under natural environmental conditions of climate, vegetation, etc., undisturbed by man. Synonymous with geological erosion.
- Normal erosion - The gradual erosion of land used by man which does not greatly exceed natural erosion.
- Rill erosion - An erosion process in which numerous small channels only several inches deep are formed; occurs mainly on recently disturbed and exposed soils. See Rill.
- Sheet erosion - The removal of a fairly uniform layer of soil from the land surface by runoff.
- Splash erosion - The spattering of small soil particles caused by the impact of raindrops on wet soils. The loosened and spattered particles may or may not be subsequently removed by surface runoff.

## **Erosion classes (soil survey)**

A grouping of erosion conditions based on the degree of erosion or on characteristic patterns. Applied to accelerated erosion, not to normal, natural, or geological erosion. Four erosion classes are recognized for water erosion and three for wind erosion.

<b>Erosion and sedimentation control</b>	Any temporary or permanent measures taken to reduce erosion; control siltation and sedimentation; and ensure that sediment-laden water does not leave the site.
<b>Erosion and sediment control facility</b>	A type of drainage facility designed to hold water for a period of time to allow sediment contained in the surface and stormwater runoff directed to the facility to settle out so as to improve the quality of the runoff.
<b>Escarpment</b>	A steep face or a ridge of high land.
<b>Estuarine wetland</b>	Generally, an eelgrass bed; salt marsh; or rocky, sandflat, or mudflat intertidal area where fresh and salt water mix. (Specifically, a tidal wetland with salinity greater than 0.5 parts per thousand, usually semi-enclosed by land but with partially obstructed or sporadic access to the open ocean).
<b>Estuary</b>	An area where fresh water meets salt water, or where the tide meets the river current (e.g., bays, mouths of rivers, salt marshes and lagoons). Estuaries serve as nurseries and spawning and feeding grounds for large groups of marine life and provide shelter and food for birds and wildlife.
<b>Eutrophication</b>	Refers to the process where nutrient over-enrichment of water leads to excessive growth of aquatic plants, especially algae.
<b>Evapotranspiration</b>	The collective term for the processes of evaporation and plant transpiration by which water is returned to the atmosphere.
<b>Excavation</b>	The mechanical removal of earth material.
<b>Exception</b>	Relief from the application of a Minimum Requirement to a project.
<b>Exfiltration</b>	The downward movement of runoff through the bottom of an infiltration BMP into the soil layer or the downward movement of water through soil.
<b>FIRM</b>	See Flood Insurance Rate Map.
<b>Fertilizer</b>	Any material or mixture used to supply one or more of the essential plant nutrient elements.
<b>Fill</b>	A deposit of earth material placed by artificial means.
<b>Filter fabric</b>	A woven or nonwoven, water-permeable material generally made of synthetic products such as polypropylene and used in stormwater management and erosion and sediment control applications to trap sediment or prevent the clogging of aggregates by fine soil particles.

<b>Filter fabric fence</b>	A temporary sediment barrier consisting of a filter fabric stretched across and attached to supporting posts and entrenched. The filter fence is constructed of stakes and synthetic filter fabric with a rigid wire fence backing where necessary for support. Also commonly referred to in the Washington Department of Transportation standard specifications as "construction geotextile for temporary silt fences."
<b>Filter strip</b>	A grassy area with gentle slopes that treats stormwater runoff from adjacent paved areas before it concentrates into a discrete channel.
<b>Flocculation</b>	The process by which suspended colloidal or very fine particles are assembled into larger masses or floccules which eventually settle out of suspension. This process occurs naturally but can also be caused through the use of such chemicals as alum.
<b>Flood</b>	An overflow or inundation that comes from a river or any other source, including (but not limited to) streams, tides, wave action, storm drains, or excess rainfall. Any relatively high stream flow overtopping the natural or artificial banks in any reach of a stream.
<b>Flood control</b>	Methods or facilities for reducing flood flows and the extent of flooding.
<b>Flood control project</b>	A structural system installed to protect land and improvements from floods by the construction of dikes, river embankments, channels, or dams.
<b>Flood frequency</b>	The frequency with which the flood of interest may be expected to occur at a site in any average interval of years. Frequency analysis defines the "n-year flood" as being the flood that will, over a long period of time, be equaled or exceeded on the average once every "n" years.
<b>Flood fringe</b>	That portion of the floodplain outside of the floodway which is covered by floodwaters during the base flood; it is generally associated with slower moving or standing water rather than rapidly flowing water.
<b>Flood hazard areas</b>	Those areas subject to inundation by the base flood. Includes, but is not limited to streams, lakes, wetlands, and closed depressions.
<b>Flood Insurance Rate Map (FIRM)</b>	The official map on which the Federal Emergency Management Agency has delineated many areas of flood hazard, floodway, and the risk premium zones.
<b>Flood Insurance Study</b>	The official report provided by the Federal Emergency Management Agency that includes flood profiles and the FIRM.
<b>Flood peak</b>	The highest value of the stage or discharge attained by a flood; thus, peak stage or peak discharge.

<b>Floodplain</b>	The total area subject to inundation by a flood including the flood fringe and floodway.
<b>Flood-proofing</b>	Adaptations that ensure a structure is substantially impermeable to the passage of water below the flood protection elevation that resists hydrostatic and hydrodynamic loads and effects of buoyancy.
<b>Flood protection elevation</b>	The base flood elevation or higher as defined by the local government.
<b>Flood protection facility</b>	Any levee, berm, wall, enclosure, raise bank, revetment, constructed bank stabilization, or armoring, that is commonly recognized by the community as providing significant protection to a property from inundation by flood waters.
<b>Flood routing</b>	An analytical technique used to compute the effects of system storage dynamics on the shape and movement of flow represented by a hydrograph.
<b>Flood stage</b>	The stage at which overflow of the natural banks of a stream begins.
<b>Floodway</b>	The channel of the river or stream and those portions of the adjoining floodplains that are reasonably required to carry and discharge the base flood flow. The portions of the adjoining floodplains which are considered to be "reasonably required" is defined by flood hazard regulations.
<b>Flow control facility</b>	A drainage facility designed to mitigate the impacts of increased surface and stormwater runoff flow rates generated by development. Flow control facilities are designed either to hold water for a considerable length of time and then release it by evaporation, plant transpiration, and/or infiltration into the ground, or to hold runoff for a short period of time, releasing it to the conveyance system at a controlled rate.
<b>Flow duration</b>	The aggregate time that peak flows are at or above a particular flow rate of interest. For example, the amount of time that peak flows are at or above 50% of the 2-year peak flow rate for a period of record.
<b>Flow frequency</b>	The inverse of the probability that the flow will be equaled or exceeded in any given year (the exceedance probability). For example, if the exceedance probability is 0.01 or 1 in 100, that flow is referred to as the 100-year flow.
<b>Flow path</b>	The route that stormwater runoff follows between two points of interest.
<b>Forebay</b>	An easily maintained, extra storage area provided near an inlet of a BMP to trap incoming sediments before they accumulate in a pond or wetland BMP.



<b>Forest practice</b>	<p>Any activity conducted on or directly pertaining to forest land and relating to growing, harvesting, or processing timber, including but not limited to:</p> <ol style="list-style-type: none"> <li>a. Road and trail construction.</li> <li>b. Harvesting, final and intermediate.</li> <li>c. Precommercial thinning.</li> <li>d. Reforestation.</li> <li>e. Fertilization.</li> <li>f. Prevention and suppression of diseases and insects.</li> <li>g. Salvage of trees.</li> <li>h. Brush control.</li> </ol>
<b>Forested communities (wetlands)</b>	<p>In general terms, communities (wetlands) characterized by woody vegetation that is greater than or equal to 6 meters in height; in this manual the term applies to such communities (wetlands) that represent a significant amount of tree cover consisting of species that offer wildlife habitat and other values and advance the performance of wetland functions overall.</p>
<b>Freeboard</b>	<p>The vertical distance between the design water surface elevation and the elevation of the barrier that contains the water.</p>
<b>Frequently flooded areas</b>	<p>The 100-year floodplain designations of the Federal Emergency Management Agency and the National Flood Insurance Program or as defined by the local government.</p>
<b>Frost-heave</b>	<p>The upward movement of soil surface due to the expansion of water stored between particles in the first few feet of the soil profile as it freezes. May cause surface fracturing of asphalt or concrete.</p>
<b>Frequency of storm (design storm frequency)</b>	<p>The anticipated period in years that will elapse, based on average probability of storms in the design region, before a storm of a given intensity and/or total volume will recur; thus a 10-year storm can be expected to occur on the average once every 10 years. Sewers designed to handle flows that occur under such storm conditions would be expected to be surcharged by any storms of greater amount or intensity.</p>

<b>Functions</b>	The ecological (physical, chemical, and biological) processes or attributes of a wetland without regard for their importance to society (see also values). Wetland functions include food chain support, provision of ecosystem diversity and fish and wildlife habitat, floodflow alteration, ground water recharge and discharge, water quality improvement, and soil stabilization.
<b>Gabion</b>	A rectangular or cylindrical wire mesh cage (a chicken wire basket) filled with rock and used as a protecting agent, revetment, etc., against erosion. Soft gabions, often used in streambank stabilization, are made of geotextiles filled with dirt, in between which cuttings are placed.
<b>Gage or gauge</b>	Device for registering precipitation, water level, discharge, velocity, pressure, temperature, etc. Also, a measure of the thickness of metal; e.g., diameter of wire, wall thickness of steel pipe.
<b>Gaging station</b>	A selected section of a stream channel equipped with a gage, recorder, or other facilities for determining stream discharge.
<b>Geologist</b>	A person who has earned a degree in geology from an accredited college or university or who has equivalent educational training and has at least five years of experience as a practicing geologist or four years of experience and at least two years post-graduate study, research or teaching. The practical experience shall include at least three years work in applied geology and landslide evaluation, in close association with qualified practicing geologists or geotechnical professional/civil engineers.
<b>Geologically hazardous areas</b>	Areas that because of their susceptibility to erosion, sliding, earthquake, or other geological events, are not suited to the siting of commercial, residential, or industrial development consistent with public health or safety concerns.
<b>Geometrics</b>	The mathematical relationships between points, lines, angles, and surfaces used to measure and identify areas of land.
<b>Geotechnical professional civil engineer</b>	A practicing, geotechnical/civil engineer licensed as a professional Civil Engineer with the State of Washington who has at least four years of professional employment as a geotechnical engineer in responsible charge, including experience with landslide evaluation.
<b>Grade</b>	The slope of a road, channel, or natural ground. The finished surface of a canal bed, roadbed, top of embankment, or bottom of excavation; any surface prepared for the support of construction such as paving or the laying of a conduit.
<b>(To) Grade</b>	To finish the surface of a canal bed, roadbed, top of embankment or bottom of excavation.

<b>Gradient terrace</b>	An earth embankment or a ridge-and-channel constructed with suitable spacing and an acceptable grade to reduce erosion damage by intercepting surface runoff and conducting it to a stable outlet at a stable nonerosive velocity.
<b>Grassed waterway</b>	A natural or constructed waterway, usually broad and shallow, covered with erosion-resistant grasses, used to conduct surface water from an area at a reduced flow rate. See also biofilter.
<b>Ground water</b>	Water in a saturated zone or stratum beneath the land surface or a surface waterbody.
<b>Ground water recharge</b>	Inflow to a ground water reservoir.
<b>Ground water table</b>	The free surface of the ground water, that surface subject to atmospheric pressure under the ground, generally rising and falling with the season, the rate of withdrawal, the rate of restoration, and other conditions. It is seldom static.
<b>Gully</b>	A channel caused by the concentrated flow of surface and stormwater runoff over unprotected erodible land.
<b>Habitat</b>	The specific area or environment in which a particular type of plant or animal lives. An organism's habitat must provide all of the basic requirements for life and should be protected from harmful biological, chemical, and physical alterations.
<b>Hardpan</b>	A cemented or compacted and often clay-like layer of soil that is impenetrable by roots. Also known as glacial till.
<b>Harmful pollutant</b>	A substance that has adverse effects to an organism including immediate death, chronic poisoning, impaired reproduction, cancer or other effects.
<b>Head (hydraulics)</b>	The height of water above any plane of reference. The energy, either kinetic or potential, possessed by each unit weight of a liquid, expressed as the vertical height through which a unit weight would have to fall to release the average energy possessed. Used in various compound terms such as pressure head, velocity head, and head loss.
<b>Head loss</b>	Energy loss due to friction, eddies, changes in velocity, or direction of flow.
<b>Heavy metals</b>	Metals of high specific gravity, present in municipal and industrial wastes, that pose long-term environmental hazards. Such metals include cadmium, chromium, cobalt, copper, lead, mercury, nickel, and zinc.

<b>High-use site</b>	<p>High-use sites are those that typically generate high concentrations of oil due to high traffic turnover or the frequent transfer of oil. High-use sites include:</p> <ul style="list-style-type: none"> <li>• An area of a commercial or industrial site subject to an expected average daily traffic (ADT) count equal to or greater than 100 vehicles per 1,000 square feet of gross building area;</li> <li>• An area of a commercial or industrial site subject to petroleum storage and transfer in excess of 1,500 gallons per year, not including routinely delivered heating oil;</li> <li>• An area of a commercial or industrial site subject to parking, storage or maintenance of 25 or more vehicles that are over 10 tons gross weight (trucks, buses, trains, heavy equipment, etc.);</li> <li>• A road intersection with a measured ADT count of 25,000 vehicles or more on the main roadway and 15,000 vehicles or more on any intersecting roadway, excluding projects proposing primarily pedestrian or bicycle use improvements.</li> </ul>
<b>Highway</b>	A main public road connecting towns and cities.
<b>Hog fuel</b>	See wood-based mulch.
<b>Horton overland flow</b>	A runoff process whereby the rainfall rate exceeds the infiltration rate, so that the precipitation that does not infiltrate flows downhill over the soil surface.
<b>HSPF</b>	<b>Hydrological Simulation Program-Fortran.</b> A continuous simulation hydrologic model that transforms an uninterrupted rainfall record into a concurrent series of runoff or flow data by means of a set of mathematical algorithms which represent the rainfall-runoff process at some conceptual level.
<b>Humus</b>	Organic matter in or on a soil, composed of partly or fully decomposed bits of plant tissue or from animal manure.
<b>Hydraulic Conductivity</b>	The quality of saturated soil that enables water or air to move through it. Also known as permeability coefficient
<b>Hydraulic gradient</b>	Slope of the potential head relative to a fixed datum.
<b>Hydrodynamics</b>	Means the dynamic energy, force, or motion of fluids as affected by the physical forces acting upon those fluids.
<b>Hydrograph</b>	A graph of runoff rate, inflow rate or discharge rate, past a specific point over time.

<b>Hydrologic cycle</b>	The circuit of water movement from the atmosphere to the earth and return to the atmosphere through various stages or processes as precipitation, interception, runoff, infiltration, percolation, storage, evaporation, and transpiration.
<b>Hydrologic Soil Groups</b>	<p>A soil characteristic classification system defined by the U.S. Soil Conservation Service in which a soil may be categorized into one of four soil groups (A, B, C, or D) based upon infiltration rate and other properties.</p> <p><u>Type A:</u> Low runoff potential. Soils having high infiltration rates, even when thoroughly wetted, and consisting chiefly of deep, well drained to excessively drained sands or gravels. These soils have a high rate of water transmission.</p> <p><u>Type B:</u> Moderately low runoff potential. Soils having moderate infiltration rates when thoroughly wetted, and consisting chiefly of moderately fine to moderately coarse textures. These soils have a moderate rate of water transmission.</p> <p><u>Type C:</u> Moderately high runoff potential. Soils having slow infiltration rates when thoroughly wetted, and consisting chiefly of soils with a layer that impedes downward movement of water, or soils with moderately fine to fine textures. These soils have a slow rate of water transmission.</p> <p><u>Type D:</u> High runoff potential. Soils having very slow infiltration rates when thoroughly wetted, and consisting chiefly of clay soils with a high swelling potential, soils with a permanent high water table, soils with a hardpan, till, or clay layer at or near the surface, soils with a compacted subgrade at or near the surface, and shallow soils or nearly impervious material. These soils have a very slow rate of water transmission.<sup>1</sup></p>
	<sup>1</sup> Vladimir Novotny and Harvey Olem. <i>Water Quality Prevention, Identification, and Management of Diffuse Pollution</i> , Van Nostrand Reinhold: New York, 1994, p. 109.
<b>Hydrology</b>	The science of the behavior of water in the atmosphere, on the surface of the earth, and underground.
<b>Hydroperiod</b>	A seasonal occurrence of flooding and/or soil saturation; it encompasses depth, frequency, duration, and seasonal pattern of inundation.
<b>Hyetograph</b>	A graph of percentages of total precipitation for a series of time steps representing the total time in which precipitation occurs.

<b>Illicit discharge</b>	All non-stormwater discharges to stormwater drainage systems that cause or contribute to a violation of state water quality, sediment quality or ground water quality standards, including but not limited to sanitary sewer connections, industrial process water, interior floor drains, car washing, and greywater systems.
<b>Impact basin</b>	A device used to dissipate the energy of flowing water. Generally constructed of concrete in the form of a partially depressed or partially submerged vessel, it may utilize baffles to dissipate velocities.
<b>Impervious</b>	A surface which cannot be easily penetrated. For instance, rain does not readily penetrate paved surfaces.
<b>Impervious surface</b>	A hard surface area which either prevents or retards the entry of water into the soil mantle as under natural conditions prior to development. A hard surface area which causes water to run off the surface in greater quantities or at an increased rate of flow from the flow present under natural conditions prior to development. Common impervious surfaces include, but are not limited to, roof tops, walkways, patios, driveways, parking lots or storage areas, concrete or asphalt paving, gravel roads, packed earthen materials, and oiled, macadam or other surfaces which similarly impede the natural infiltration of stormwater. Open, uncovered retention/detention facilities shall not be considered as impervious surfaces for the purposes of determining whether the thresholds for application of minimum requirements are exceeded. Open, uncovered retention/detention facilities shall be considered impervious surfaces for purposes of runoff modeling.
<b>Impoundment</b>	A natural or man-made containment for surface water.
<b>Improvement</b>	Streets (with or without curbs or gutters), sidewalks, crosswalks, parking lots, water mains, sanitary and storm sewers, drainage facilities, street trees and other appropriate items.
<b>Industrial activities</b>	Material handling, transportation, or storage; manufacturing; maintenance; treatment; or disposal. Areas with industrial activities include plant yards, access roads and rail lines used by carriers of raw materials, manufactured products, waste material, or by-products; material handling sites; refuse sites; sites used for the application or disposal of process waste waters; sites used for the storage and maintenance of material handling equipment; sites used for residual treatment, storage, or disposal; shipping and receiving areas; manufacturing buildings; storage areas for raw materials, and intermediate and finished products; and areas where industrial activity has taken place in the past and significant materials remain and are exposed to stormwater.
<b>Infiltration</b>	Means the downward movement of water from the surface to the subsoil.

<b>Infiltration facility (or system)</b>	A drainage facility designed to use the hydrologic process of surface and stormwater runoff soaking into the ground, commonly referred to as a percolation, to dispose of surface and stormwater runoff.
<b>Infiltration rate</b>	The rate, usually expressed in inches/hour, at which water moves downward (percolates) through the soil profile. Short-term infiltration rates may be inferred from soil analysis or texture or derived from field measurements. Long-term infiltration rates are affected by variability in soils and subsurface conditions at the site, the effectiveness of pretreatment or influent control, and the degree of long-term maintenance of the infiltration facility.
<b>Ingress/egress</b>	The points of access to and from a property.
<b>Inlet</b>	A form of connection between surface of the ground and a drain or sewer for the admission of surface and stormwater runoff.
<b>Insecticide</b>	A substance, usually chemical, that is used to kill insects.
<b>Interception (Hydraulics)</b>	The process by which precipitation is caught and held by foliage, twigs, and branches of trees, shrubs, and other vegetation. Often used for "interception loss" or the amount of water evaporated from the precipitation intercepted.
<b>Interflow</b>	That portion of rainfall that infiltrates into the soil and moves laterally through the upper soil horizons until intercepted by a stream channel or until it returns to the surface for example, in a roadside ditch, wetland, spring or seep. Interflow is a function of the soil system depth, permeability, and water-holding capacity.
<b>Intermittent stream</b>	A stream or portion of a stream that flows only in direct response to precipitation. It receives little or no water from springs and no long-continued supply from melting snow or other sources. It is dry for a large part of the year, ordinarily more than three months.
<b>Invasive weedy plant species</b>	Opportunistic species of inferior biological value that tend to out-compete more desirable forms and become dominant; applied to non-native species in this manual.
<b>Invert</b>	The lowest point on the inside of a sewer or other conduit.
<b>Invert elevation</b>	The vertical elevation of a pipe or orifice in a pond that defines the water level.
<b>Isopluvial map</b>	A map with lines representing constant depth of total precipitation for a given return frequency.
<b>Lag time</b>	The interval between the center of mass of the storm precipitation and the peak flow of the resultant runoff.

<b>Lake</b>	An area permanently inundated by water in excess of two meters deep and greater than 20 acres in size as measured at the ordinary high water marks.
<b>Land disturbing activity</b>	Any activity that results in a movement of earth or a change in the existing soil cover (both vegetative and nonvegetative) and/or the existing soil topography. Land disturbing activities include, but are not limited to clearing, grading, filling, and excavation. Compaction that is associated with stabilization of structures and road construction shall also be considered a land disturbing activity. Vegetation maintenance practices are not considered land-disturbing activity.
<b>Landslide</b>	Episodic downslope movement of a mass of soil or rock that includes but is not limited to rockfalls, slumps, mudflows, and earthflows. For the purpose of these rules, snow avalanches are considered to be a special case of landsliding.
<b>Landslide hazard areas</b>	Those areas subject to a severe risk of landslide.
<b>Leachable materials</b>	Those substances that, when exposed to rainfall, measurably alter the physical or chemical characteristics of the rainfall runoff. Examples include erodible soils, uncovered process wastes, manure, fertilizers, oil substances, ashes, kiln dust, and garbage dumpster leakage.
<b>Leachate</b>	Liquid that has percolated through soil and contains substances in solution or suspension.
<b>Leaching</b>	Removal of the more soluble materials from the soil by percolating waters.
<b>Legume</b>	A member of the legume or pulse family, <u>Leguminosae</u> , one of the most important and widely distributed plant families. The fruit is a "legume" or pod. Includes many valuable food and forage species, such as peas, beans, clovers, alfalfas, sweet clovers, and vetches. Practically all legumes are nitrogen-fixing plants.
<b>Level pool routing</b>	The basic technique of storage routing used for sizing and analyzing detention storage and determining water levels for ponding water bodies. The level pool routing technique is based on the continuity equation: $\text{Inflow} - \text{Outflow} = \text{Change in storage}$ .
<b>Level spreader</b>	A temporary ESC device used to spread out stormwater runoff uniformly over the ground surface as sheet flow (i.e., not through channels). The purpose of level spreaders is to prevent concentrated, erosive flows from occurring, and to enhance infiltration.
<b>Local government</b>	Any county, city, town, or special purpose district having its own incorporated government for local affairs.



<b>Low flow channel</b>	An incised or paved channel from inlet to outlet in a dry basin which is designed to carry low runoff flows and/or baseflow, directly to the outlet without detention.
<b>Low permeable liner</b>	A layer of compacted till or clay, or a geomembrane.
<b>Lowest floor</b>	The lowest enclosed area (including basement) of a structure. An area used solely for parking of vehicles, building access, or storage, in an area other than a basement area, is not considered a building's lowest floor, provided that the enclosed area meets all of the structural requirements of the flood hazard standards.
<b>MDNS</b>	A Mitigated Determination of Nonsignificance (See DNS and Mitigation).
<b>Maintenance</b>	Repair and maintenance includes activities conducted on currently serviceable structures, facilities, and equipment that involves no expansion or use beyond that previously existing and resulting in no significant adverse hydrologic impact. It includes those usual activities taken to prevent a decline, lapse, or cessation in the use of structures and systems and includes replacement of disfunctioning facilities, including cases where environmental permits require replacing an existing structure with a different type structure, as long as the functioning characteristics of the original structure are not changed. For example, replacing a collapsed, fish blocking, round culvert with a new box culvert under the same span, or width, of roadway. For further details on the application of this manual to various road management functions, please see Section 2.2 in chapter 2 of Volume I.
<b>Manning's equation</b>	<p>An equation used to predict the velocity of water flow in an open channel or pipelines:</p> $V = \frac{1.486R^{2/3}S^{1/2}}{n}$ <p>where:</p> <p>V is the mean velocity of flow in feet per second</p> <p>R is the hydraulic radius in feet</p> <p>S is the slope of the energy gradient or, for assumed uniform flow, the slope of the channel in feet per foot; and</p> <p>n is Manning's roughness coefficient or retardance factor of the channel lining.</p>
<b>Mass wasting</b>	The movement of large volumes of earth material downslope.

<b>Master drainage plan</b>	A comprehensive drainage control plan intended to prevent significant adverse impacts to the natural and manmade drainage system, both on and off-site.
<b>Mean annual water level fluctuation</b>	<p>Derived as follows:</p> <ol style="list-style-type: none"> <li>(1) Measure the maximum water level (e.g., with a crest stage gage, Reinelt and Horner 1990) and the existing water level at the time of the site visit (e.g., with a staff gage) on at least eight occasions spread through a year.</li> <li>(2) Take the difference of the maximum and existing water level on each occasion and divide by the number of occasions.</li> </ol>
<b>Mean depth</b>	Average depth; cross-sectional area of a stream or channel divided by its surface or top width.
<b>Mean velocity</b>	The average velocity of a stream flowing in a channel or conduit at a given cross-section or in a given reach. It is equal to the discharge divided by the cross-sectional area of the reach.
<b>Measuring weir</b>	A shaped notch through which water flows are measured. Common shapes are rectangular, trapezoidal, and triangular.
<b>Mechanical analysis</b>	The analytical procedure by which soil particles are separated to determine the particle size distribution.
<b>Mechanical practices</b>	Soil and water conservation practices that primarily change the surface of the land or that store, convey, regulate, or dispose of runoff water without excessive erosion.
<b>Metals</b>	Elements, such as mercury, lead, nickel, zinc and cadmium, which are of environmental concern because they do not degrade over time. Although many are necessary nutrients, they are sometimes magnified in the food chain, and they can be toxic to life in high enough concentrations. They are also referred to as heavy metals.
<b>Microbes</b>	The lower trophic levels of the soil food web. They are normally considered to include bacteria, fungi, flagellates, amoebae, ciliates, and nematodes. These in turn support the higher trophic levels, such as mites and earthworms. Together they are the basic life forms that are necessary for plant growth. Soil microbes also function to bioremediate pollutants such as petroleum, nutrients, and pathogens.
<b>Mitigation</b>	<p>Means, in the following order of preference:</p> <ol style="list-style-type: none"> <li>(a) Avoiding the impact altogether by not taking a certain action or part of an action;</li> </ol>

- (b) Minimizing impacts by limiting the degree or magnitude of the action and its implementation, by using appropriate technology, or by taking affirmative steps to avoid or reduce impacts;
- (c) Rectifying the impact by repairing, rehabilitating or restoring the affected environment;
- (d) Reducing or eliminating the impact over time by preservation and maintenance operations during the life of the action; and
- (e) Compensating for the impact by replacing, enhancing, or providing substitute resources or environments.

**Modification, modified (wetland)**

A wetland whose physical, hydrological, or water quality characteristics have been purposefully altered for a management purpose, such as by dredging, filling, forebay construction, and inlet or outlet control.

**Monitor**

To systematically and repeatedly measure something in order to track changes.

**Monitoring**

The collection of data by various methods for the purposes of understanding natural systems and features, evaluating the impacts of development proposals on such systems, and assessing the performance of mitigation measures imposed as conditions of development.

**NGPE**

See Native Growth Protection Easement.

**NGVD**

National Geodetic Vertical Datum.

**NPDES**

The National Pollutant Discharge Elimination System as established by the Federal Clean Water Act.

**National Pollutant Discharge Elimination System (NPDES)**

The part of the federal Clean Water Act, which requires point source dischargers to obtain permits. These permits are referred to as NPDES permits and, in Washington State, are administered by the Washington State Department of Ecology.

**Native Growth Protection Easement (NGPE)**

An easement granted for the protection of native vegetation within a sensitive area or its associated buffer. The NGPE shall be recorded on the appropriate documents of title and filed with the County Records Division.

**Native vegetation**

Vegetation comprised of plant species, other than noxious weeds, that are indigenous to the coastal region of the Pacific Northwest and which reasonably could have been expected to naturally occur on the site. Examples include trees such as Douglas fir, Western Hemlock, Western Red Cedar, Alder, Big-leaf Maple, and Vine Maple; shrubs such as willow, elderberry, salmonberry and salal; and herbaceous plants such as sword fern, foam flower, and fireweed.

<b>Natural location</b>	Means the location of those channels, swales, and other non-manmade conveyance systems as defined by the first documented topographic contours existing for the subject property, either from maps or photographs, or such other means as appropriate. In the case of outwash soils with relatively flat terrain, no natural location of surface discharge may exist.
<b>New development</b>	Land disturbing activities, including Class IV -general forest practices that are conversions from timber land to other uses; structural development, including construction or installation of a building or other structure; creation of impervious surfaces; and subdivision, short subdivision and binding site plans, as defined and applied in Chapter 58.17 RCW. Projects meeting the definition of redevelopment shall not be considered new development.
<b>Nitrate (NO<sub>3</sub>)</b>	A form of nitrogen which is an essential nutrient to plants. It can cause algal blooms in water if all other nutrients are present in sufficient quantities. It is a product of bacterial oxidation of other forms of nitrogen, from the atmosphere during electrical storms and from fertilizer manufacturing.
<b>Nitrification</b>	The biochemical oxidation process by which ammonia is changed first to nitrites and then to nitrates by bacterial action, consuming oxygen in the water.
<b>Nitrogen, Available</b>	Usually ammonium, nitrite, and nitrate ions, and certain simple amines available for plant growth. A small fraction of organic or total nitrogen in the soil is available at any time.
<b>Nonpoint source pollution</b>	Pollution that enters a waterbody from diffuse origins on the watershed and does not result from discernible, confined, or discrete conveyances.
<b>Normal depth</b>	The depth of uniform flow. This is a unique depth of flow for any combination of channel characteristics and flow conditions. Normal depth is calculated using Manning's Equation.
<b>NRCS Method</b>	See SCS Method.
<b>Nutrients</b>	Essential chemicals needed by plants or animals for growth. Excessive amounts of nutrients can lead to degradation of water quality and algal blooms. Some nutrients can be toxic at high concentrations.
<b>Off-line facilities</b>	Water quality treatment facilities to which stormwater runoff is restricted to some maximum flow rate or volume by a flow-splitter.
<b>Offsite</b>	Any area lying upstream of the site that drains onto the site and any area lying downstream of the site to which the site drains.

<b>Off-system storage</b>	Facilities for holding or retaining excess flows over and above the carrying capacity of the stormwater conveyance system, in chambers, tanks, lagoons, ponds, or other basins that are not a part of the subsurface sewer system.
<b>Oil/water separator</b>	A vault, usually underground, designed to provide a quiescent environment to separate oil from water.
<b>On-line facilities</b>	Water quality treatment facilities which receive all of the stormwater runoff from a drainage area. Flows above the water quality design flow rate or volume are passed through at a lower percent removal efficiency.
<b>On-site</b>	The entire property that includes the proposed development.
<b>On-site Stormwater Management BMPs</b>	Site development techniques that serve to infiltrate, disperse, and retain stormwater runoff on-site.
<b>Operational BMPs</b>	Operational BMPs are a type of Source Control BMP. They are schedules of activities, prohibition of practices, and other managerial practices to prevent or reduce pollutants from entering stormwater. Operational BMPs include formation of a pollution prevention team, good housekeeping, preventive maintenance procedures, spill prevention and clean-up, employee training, inspections of pollutant sources and BMPs, and record keeping. They can also include process changes, raw material/product changes, and recycling wastes.
<b>Ordinary high water mark</b>	<p>The term ordinary high water mark means the line on the shore established by the fluctuations of water and indicated by physical characteristics such as a clear, natural line impressed on the bank; shelving; changes in the character of soil destruction on terrestrial vegetation, or the presence of litter and debris; or other appropriate means that consider the characteristics of the surrounding area.</p> <p>The ordinary high water mark will be found by examining the bed and banks of a stream and ascertaining where the presence and action of waters are so common and usual, and so long maintained in all ordinary years, as to mark upon the soil a character distinct from that of the abutting upland, in respect to vegetation. In any area where the ordinary high water mark cannot be found, the line of mean high water shall substitute. In any area where neither can be found, the channel bank shall be substituted. In braided channels and alluvial fans, the ordinary high water mark or substitute shall be measured so as to include the entire stream feature.</p>
<b>Organic matter</b>	Organic matter as decomposed animal or vegetable matter. It is measured by ASTM D 2974. Organic matter is an important reservoir of carbon and a dynamic component of soil and the carbon cycle. It improves soil and plant efficiency by improving soil physical properties

including drainage, aeration, and other structural characteristics. It contains the nutrients, microbes, and higher-form soil food web organisms necessary for plant growth. The maturity of organic matter is a measure of its beneficial properties. Raw organic matter can release water-soluble nutrients (similar to chemical fertilizer). Beneficial organic matter has undergone a humification process either naturally in the environment or through a composting process.

<b>Orifice</b>	An opening with closed perimeter, usually sharp-edged, and of regular form in a plate, wall, or partition through which water may flow, generally used for the purpose of measurement or control of water.
<b>Outlet</b>	Point of water disposal from a stream, river, lake, tidewater, or artificial drain.
<b>Outlet channel</b>	A waterway constructed or altered primarily to carry water from man-made structures, such as terraces, tile lines, and diversions.
<b>Outwash soils</b>	Soils formed from highly permeable sands and gravels.
<b>Overflow</b>	<p>A pipeline or conduit device, together with an outlet pipe, that provides for the discharge of portions of combined sewer flows into receiving waters or other points of disposal, after a regular device has</p> <p>allowed the portion of the flow which can be handled by interceptor sewer lines and pumping and treatment facilities to be carried by and to such water pollution control structures.</p>
<b>Overflow rate</b>	Detention basin release rate divided by the surface area of the basin. It can be thought of as an average flow rate through the basin.
<b>Overtopping</b>	To flow over the limits of a containment or conveyance element.
<b>Particle Size</b>	The effective diameter of a particle as measured by sedimentation, sieving, or micrometric methods.
<b>Peak discharge</b>	The maximum instantaneous rate of flow during a storm, usually in reference to a specific design storm event.
<b>Peak-shaving</b>	Controlling post-development peak discharge rates to pre-development levels by providing temporary detention in a BMP.
<b>Percolation</b>	The movement of water through soil.
<b>Percolation rate</b>	The rate, often expressed in minutes/inch, at which clear water, maintained at a relatively constant depth, will seep out of a standardized test hole that has been previously saturated. The term percolation rate is often used synonymously with infiltration rate (short-term infiltration rate).

<b>Permanent Stormwater Control (PSC) Plan</b>	A plan which includes permanent BMPs for the control of pollution from stormwater runoff after construction and/or land disturbing activity has been completed
<b>Permeable soils</b>	Soil materials with a sufficiently rapid infiltration rate so as to greatly reduce or eliminate surface and stormwater runoff. These soils are generally classified as SCS hydrologic soil types A and B.
<b>Person</b>	Any individual, partnership, corporation, association, organization, cooperative, public or municipal corporation, agency of the state, or local government unit, however designated.
<b>Perviousness</b>	Related to the size and continuity of void spaces in soils; related to a soil's infiltration rate.
<b>Pesticide</b>	A general term used to describe any substance - usually chemical - used to destroy or control organisms; includes herbicides, insecticides, algicides, fungicides, and others. Many of these substances are manufactured and are not naturally found in the environment. Others, such as pyrethrum, are natural toxins that are extracted from plants and animals.
<b>pH</b>	A measure of the alkalinity or acidity of a substance which is conducted by measuring the concentration of hydrogen ions in the substance. A pH of 7.0 indicates neutral water. A 6.5 reading is slightly acid.
<b>Physiographic</b>	Characteristics of the natural physical environment (including hills).
<b>Plan Approval Authority</b>	The Plan Approval Authority is defined as that department within a local government that has been delegated authority to approve stormwater site plans.
<b>Planned unit development (PUD)</b>	A special classification authorized in some zoning ordinances, where a unit of land under control of a single developer may be used for a variety of uses and densities, subject to review and approval by the local governing body. The locations of the zones are usually decided on a case-by-case basis.
<b>Plat</b>	A map or representation of a subdivision showing the division of a tract or parcel of land into lots, blocks, streets, or other divisions and dedications.
<b>Plunge pool</b>	A device used to dissipate the energy of flowing water that may be constructed or made by the action of flowing. These facilities may be protected by various lining materials.
<b>Point discharge</b>	The release of collected and/or concentrated surface and stormwater runoff from a pipe, culvert, or channel.

<b>Point of compliance</b>	The location at which compliance with a discharge performance standard or a receiving water quality standard is measured.
<b>Pollution</b>	Contamination or other alteration of the physical, chemical, or biological properties, of waters of the state, including change in temperature, taste, color, turbidity, or odor of the waters, or such discharge of any liquid, gaseous, solid, radioactive or other substance into any waters of the state as will or is likely to create a nuisance or render such waters harmful, detrimental or injurious to the public health, safety or welfare, or to domestic, commercial, industrial, agricultural, recreational, or other legitimate beneficial uses, or to livestock, wild animals, birds, fish or other aquatic life.
<b>Pollution-generating impervious surface (PGIS)</b>	<p>Those impervious surfaces considered to be a significant source of pollutants in stormwater runoff. Such surfaces include those which are subject to: vehicular use; industrial activities (as further defined in this glossary); or storage of erodible or leachable materials, wastes, or chemicals, and which receive direct rainfall or the run-on or blow-in of rainfall. Erodible or leachable materials, wastes, or chemicals are those substances which, when exposed to rainfall, measurably alter the physical or chemical characteristics of the rainfall runoff. Examples include erodible soils that are stockpiled, uncovered process wastes, manure, fertilizers, oily substances, ashes, kiln dust, and garbage dumpster leakage. Metal roofs are also considered to be PGIS unless they are coated with an inert, non-leachable material (e.g., baked-on enamel coating).</p> <p>A surface, whether paved or not, shall be considered subject to vehicular use if it is regularly used by motor vehicles. The following are considered regularly-used surfaces: roads, unvegetated road shoulders, bike lanes within the traveled lane of a roadway, driveways, parking lots, unfenced fire lanes, vehicular equipment storage yards, and airport runways.</p> <p>The following are not considered regularly-used surfaces: paved bicycle pathways separated from and not subject to drainage from roads for motor vehicles, fenced fire lanes, and infrequently used maintenance access roads.</p>
<b>Pollution-generating pervious surface (PGPS)</b>	Any non-impervious surface subject to use of pesticides and fertilizers or loss of soil. Typical PGPS include lawns, landscaped areas, golf courses, parks, cemeteries, and sports fields.
<b>Predeveloped Condition</b>	The native vegetation and soils that existed at a site prior to the influence of Euro-American settlement. The pre-developed condition shall be assumed to be forested land cover unless reasonable, historic information is provided that indicates the site was prairie prior to settlement.



<b>Prediction</b>	For the purposes of this document an expected outcome based on the results of hydrologic modeling and/or the judgment of a trained professional civil engineer or geologist.
<b>Pretreatment</b>	The removal of material such as solids, grit, grease, and scum from flows prior to physical, biological, or physical treatment processes to improve treatability. Pretreatment may include screening, grit removal, settling, oil/water separation, or application of a Basic Treatment BMP prior to infiltration.
<b>Priority peat systems</b>	Unique, irreplaceable fens that can exhibit water pH in a wide range from highly acidic to alkaline, including fens typified by Sphagnum species, <u>Ledum groenlandicum</u> (Labrador tea), <u>Drosera rotundifolia</u> (sundew), and <u>Vaccinium oxycoccos</u> (bog cranberry); marl fens; estuarine peat deposits; and other moss peat systems with relatively diverse, undisturbed flora and fauna. Bog is the common name for peat systems having the Sphagnum association described, but this term applies strictly only to systems that receive water income from precipitation exclusively.
<b>Professional civil engineer</b>	A person registered with the state of Washington as a professional engineer in civil engineering.
<b>Project</b>	Any proposed action to alter or develop a site. The proposed action of a permit application or an approval, which requires drainage review.
<b>Project site</b>	That portion of a property, properties, or right of way subject to land disturbing activities, new impervious surfaces, or replaced impervious surfaces.
<b>Properly Functioning Soil System (PFSS)</b>	Equivalent to engineered soil/landscape system. This can also be a natural system that has not been disturbed or modified.
<b>Puget Sound basin</b>	Puget Sound south of Admiralty Inlet (including Hood Canal and Saratoga Passage); the waters north to the Canadian border, including portions of the Strait of Georgia; the Strait of Juan de Fuca south of the Canadian border; and all the lands draining into these waters as mapped in Water Resources Inventory Areas numbers 1 through 19, set forth in WAC 173-500-040.
<b>R/D</b>	See Retention/detention facility.
<b>Rare, threatened, or endangered species</b>	Plant or animal species that are regional relatively uncommon, are nearing endangered status, or whose existence is in immediate jeopardy and is usually restricted to highly specific habitats. Threatened and endangered species are officially listed by federal and state authorities, whereas rare species are unofficial species of concern that fit the above definitions.

<b>Rational method</b>	A means of computing storm drainage flow rates (Q) by use of the formula $Q = CIA$ , where C is a coefficient describing the physical drainage area, $I$ is the rainfall intensity and $A$ is the area. This method is no longer used in the technical manual.
<b>Reach</b>	A length of channel with uniform characteristics.
<b>Receiving waters</b>	Bodies of water or surface water systems to which surface runoff is discharged via a point source of stormwater or via sheet flow.
<b>Recharge</b>	The addition of water to the zone of saturation (i.e., an aquifer).
<b>Recommended BMPs</b>	As used in Volume IV, recommended BMPs are those BMPs that are not expected to be mandatory by local governments at new development and redevelopment sites. However, they may improve pollutant control efficiency, and may provide a more comprehensive and environmentally effective stormwater management program.
<b>Redevelopment</b>	On a site that is already substantially developed (i.e., has 35% or more of existing impervious surface coverage), the creation or addition of impervious surfaces; the expansion of a building footprint or addition or replacement of a structure; structural development including construction, installation or expansion of a building or other structure; replacement of impervious surface that is not part of a routine maintenance activity; and land disturbing activities.
<b>Regional</b>	An action (here, for stormwater management purposes) that involves more than one discrete property.
<b>Regional detention facility</b>	A stormwater quantity control structure designed to correct existing surface water runoff problems of a basin or subbasin. The area downstream has been previously identified as having existing or predicted significant and regional flooding and/or erosion problems.  This term is also used when a detention facility is sited to detain stormwater runoff from a number of new developments or areas within a catchment.
<b>Release rate</b>	The computed peak rate of surface and stormwater runoff from a site.
<b>Replaced impervious surface</b>	For structures, the removal and replacement of any exterior impervious surfaces or foundation. For other impervious surfaces, the removal down to bare soil or base course and replacement.
<b>Residential density</b>	The number of dwelling units per unit of surface area. Net density includes only occupied land. Gross density includes unoccupied portions of residential areas, such as roads and open space.

<b>Restoration</b>	Actions performed to reestablish wetland functional characteristics and processes that have been lost by alterations, activities, or catastrophic events in an area that no longer meets the definition of a wetland.
<b>Retention</b>	The process of collecting and holding surface and stormwater runoff with no surface outflow.
<b>Retention/detention facility (R/D)</b>	A type of drainage facility designed either to hold water for a considerable length of time and then release it by evaporation, plant transpiration, and/or infiltration into the ground; or to hold surface and stormwater runoff for a short period of time and then release it to the surface and stormwater management system.
<b>Retrofitting</b>	The renovation of an existing structure or facility to meet changed conditions or to improve performance.
<b>Return frequency</b>	A statistical term for the average time of expected interval that an event of some kind will equal or exceed given conditions (e.g., a stormwater flow that occurs every 2 years).
<b>Rhizome</b>	A modified plant stem that grows horizontally underground.
<b>Riffles</b>	Fast sections of a stream where shallow water races over stones and gravel. Riffles usually support a wider variety of bottom organisms than other stream sections.
<b>Rill</b>	A small intermittent watercourse with steep sides, usually only a few inches deep. Often rills are caused by an increase in surface water flow when soil is cleared of vegetation.
<b>Riprap</b>	A facing layer or protective mound of rocks placed to prevent erosion or sloughing of a structure or embankment due to flow of surface and stormwater runoff.
<b>Riparian</b>	Pertaining to the banks of streams, wetlands, lakes, or tidewater.
<b>Riser</b>	A vertical pipe extending from the bottom of a pond BMP that is used to control the discharge rate from a BMP for a specified design storm.
<b>Rodenticide</b>	A substance used to destroy rodents.
<b>Runoff</b>	Water originating from rainfall and other precipitation that is found in drainage facilities, rivers, streams, springs, seeps, ponds, lakes and wetlands as well as shallow ground water. As applied in this manual, it also means the portion of rainfall or other precipitation that becomes surface flow and interflow.
<b>SCS</b>	Soil Conservation Service (now the Natural Resources Conservation Service), U.S. Department of Agriculture

<b>SCS Method</b>	A single-event hydrologic analysis technique for estimating runoff based on the Curve Number method. The Curve Numbers are published by NRCS <i>in Urban Hydrology for Small Watersheds, 55 TR, June 1976</i> . With the change in name to the Natural Resource Conservation Service, the method may be referred to as the NRCS Method.
<b>SEPA</b>	See State Environmental Policy Act.
<b>Salmonid</b>	A member of the fish family <i>Salmonidae</i> . Chinook, coho, chum, sockeye and pink salmon; cutthroat, brook, brown, rainbow, and steelhead trout; Dolly Varden, kokanee, and char are examples of salmonid species.
<b>Sand filter</b>	A man-made depression or basin with a layer of sand that treats stormwater as it percolates through the sand and is discharged via a central collector pipe.
<b>Saturation point</b>	In soils, the point at which a soil or an aquifer will no longer absorb any amount of water without losing an equal amount.
<b>Scour</b>	Erosion of channel banks due to excessive velocity of the flow of surface and stormwater runoff.
<b>Sediment</b>	Fragmented material that originates from weathering and erosion of rocks or unconsolidated deposits, and is transported by, suspended in, or deposited by water.
<b>Sedimentation</b>	The depositing or formation of sediment.
<b>Sensitive emergent vegetation communities</b>	Assemblages of erect, rooted, herbaceous vegetation, excluding mosses and lichens, at least some of whose members have relatively narrow ranges of environmental requirements, such as hydroperiod, nutrition, temperature, and light. Examples include fen species such as sundew and, as well as a number of species of <i>Carex</i> (sedges).
<b>Sensitive life stages</b>	Stages during which organisms have limited mobility or alternatives in securing the necessities of life, especially including reproduction, rearing, and migration periods.
<b>Sensitive scrub-shrub vegetation communities</b>	Assemblages of woody vegetation less than 6 meters in height, at least some of whose members have relatively narrow ranges of environmental requirements, such as hydroperiod, nutrition, temperature, and light. Examples include fen species such as Labrador tea, bog laurel, and cranberry.
<b>Settleable solids</b>	Those suspended solids in stormwater that separate by settling when the stormwater is held in a quiescent condition for a specified time.

<b>Sheet erosion</b>	The relatively uniform removal of soil from an area without the development of conspicuous water channels.
<b>Sheet flow</b>	Runoff that flows over the ground surface as a thin, even layer, not concentrated in a channel.
<b>Shoreline development</b>	The proposed project as regulated by the Shoreline Management Act. Usually the construction over water or within a shoreline zone (generally 200 feet landward of the water) of structures such as buildings, piers, bulkheads, and breakwaters, including environmental alterations such as dredging and filling, or any project which interferes with public navigational rights on the surface waters.
<b>Short circuiting</b>	The passage of runoff through a BMP in less than the design treatment time.
<b>Siltation</b>	The process by which a river, lake, or other waterbody becomes clogged with sediment. Silt can clog gravel beds and prevent successful salmon spawning.
<b>Site</b>	The legal boundaries of a parcel or parcels of land that is (are) subject to new development or redevelopment. For road projects, the length of the project site and the right-of-way boundaries define the site.
<b>Slope</b>	Degree of deviation of a surface from the horizontal; measured as a numerical ratio, percent, or in degrees. Expressed as a ratio, the first number is the horizontal distance (run) and the second is the vertical distance (rise), as 2:1. A 2:1 slope is a 50 percent slope. Expressed in degrees, the slope is the angle from the horizontal plane, with a 90° slope being vertical (maximum) and 45° being a 1:1 or 100 percent slope.
<b>Sloughing</b>	The sliding of overlying material. It is the same effect as caving, but it usually occurs when the bank or an underlying stratum is saturated or scoured.
<b>Soil</b>	The unconsolidated mineral and organic material on the immediate surface of the earth that serves as a natural medium for the growth of land plants. See also topsoil, engineered soil/landscape system, and properly functioning soil system.
<b>Soil group, hydrologic</b>	A classification of soils by the Soil Conservation Service into four runoff potential groups. The groups range from A soils, which are very permeable and produce little or no runoff, to D soils, which are not very permeable and produce much more runoff.
<b>Soil horizon</b>	A layer of soil, approximately parallel to the surface, which has distinct characteristics produced by soil-forming factors.
<b>Soil profile</b>	A vertical section of the soil from the surface through all horizons, including C horizons.

<b>Soil structure</b>	The relation of particles or groups of particles which impart to the whole soil a characteristic manner of breaking; some types are crumb structure, block structure, platy structure, and columnar structure.
<b>Soil permeability</b>	The ease with which gases, liquids, or plant roots penetrate or pass through a layer of soil.
<b>Soil stabilization</b>	The use of measures such as rock lining, vegetation or other engineering structures to prevent the movement of soil when loads are applied to the soil.
<b>Soil Texture Class</b>	The relative proportion, by weight, of particle sizes, based on the USDA system, of individual soil grains less than 2 mm equivalent diameter in a mass of soil. The basic texture classes in the approximate order of increasing proportions of fine particles include: sand, loamy sand, sandy loam, loam, silt loam, silt, clay loam, sandy clay, silty clay, and clay.
<b>Sorption</b>	The physical or chemical binding of pollutants to sediment or organic particles.
<b>Source control BMP</b>	A structure or operation that is intended to prevent pollutants from coming into contact with stormwater through physical separation of areas or careful management of activities that are sources of pollutants. This manual separates source control BMPs into two types. <i>Structural source control BMPs</i> are physical, structural, or mechanical devices or facilities that are intended to prevent pollutants from entering stormwater. <i>Operational BMPs</i> are non-structural practices that prevent or reduce pollutants from entering stormwater. See Volume IV for details.
<b>Spill control device</b>	A Tee section or turn down elbow designed to retain a limited volume of pollutant that floats on water, such as oil or antifreeze. Spill control devices are passive and must be cleaned-out for the spilled pollutant to actually be removed.
<b>Spillway</b>	A passage such as a paved apron or channel for surplus water over or around a dam or similar obstruction. An open or closed channel, or both, used to convey excess water from a reservoir. It may contain gates, either manually or automatically controlled, to regulate the discharge of excess water.
<b>State Environmental Policy Act (SEPA) RCW 43.21C</b>	The Washington State law intended to minimize environmental damage. SEPA requires that state agencies and local governments consider environmental factors when making decisions on activities, such as development proposals over a certain size and comprehensive plans. As part of this process, environmental documents are prepared and opportunities for public comment are provided.

<b>Steep slope</b>	<p>Slopes of 40 percent gradient or steeper within a vertical elevation change of at least ten feet. A slope is delineated by establishing its toe and top, and is measured by averaging the inclination over at least ten feet of vertical relief. For the purpose of this definition:</p> <p>The toe of a slope is a distinct topographic break in slope that separates slopes inclined at less than 40% from slopes 40% or steeper. Where no distinct break exists, the toe of a steep slope is the lower-most limit of the area where the ground surface drops ten feet or more vertically within a horizontal distance of 25 feet; AND</p> <p>The top of a slope is a distinct topographic break in slope that separates slopes inclined at less than 40% from slopes 40% or steeper. Where no distinct break exists, the top of a steep slope is the upper-most limit of the area where the ground surface drops ten feet or more vertically within a horizontal distance of 25 feet.</p>
<b>Storage routing</b>	A method to account for the attenuation of peak flows passing through a detention facility or other storage feature.
<b>Storm drains</b>	The enclosed conduits that transport surface and stormwater runoff toward points of discharge (sometimes called storm sewers).
<b>Storm drain system</b>	Refers to the system of gutters, pipes, streams, or ditches used to carry surface and stormwater from surrounding lands to streams, lakes, or Puget Sound.
<b>Storm frequency</b>	The time interval between major storms of predetermined intensity and volumes of runoff for which storm sewers and other structures are designed and constructed to handle hydraulically without surcharging and backflooding, e.g., a 2-year, 10-year or 100-year storm.
<b>Storm sewer</b>	A sewer that carries stormwater and surface water, street wash and other wash waters or drainage, but excludes sewage and industrial wastes. Also called a storm drain.
<b>Stormwater</b>	That portion of precipitation that does not naturally percolate into the ground or evaporate, but flows via overland flow, interflow, pipes and other features of a stormwater drainage system into a defined surface waterbody, or a constructed infiltration facility.
<b>Stormwater drainage system</b>	Constructed and natural features which function together as a system to collect, convey, channel, hold, inhibit, retain, detain, infiltrate, divert, treat or filter stormwater.
<b>Stormwater facility</b>	A constructed component of a stormwater drainage system, designed or constructed to perform a particular function, or multiple functions. Stormwater facilities include, but are not limited to, pipes, swales, ditches, culverts, street gutters, detention ponds, retention ponds, constructed wetlands, infiltration devices, catch basins, oil/water separators, and biofiltration swales.

<b>Stormwater Management Manual for Western Washington (Stormwater Manual)</b>	This manual, as prepared by Ecology, contains BMPs to prevent, control or treat pollution in stormwater and reduce other stormwater-related impacts to waters of the State. The Stormwater Manual is intended to provide guidance on measures necessary in western Washington to control the quantity and quality of stormwater runoff from new development and redevelopment.
<b>Stormwater Program</b>	Either the Basic Stormwater Program or the Comprehensive Stormwater Program (as appropriate to the context of the reference) called for under the Puget Sound Water Quality Management Plan.
<b>Stormwater Site Plan</b>	The comprehensive report containing all of the technical information and analysis necessary for regulatory agencies to evaluate a proposed new development or redevelopment project for compliance with stormwater requirements. Contents of the Stormwater Site Plan will vary with the type and size of the project, and individual site characteristics. It includes a Construction Stormwater Pollution Prevention Plan (Construction SWPPP) and a Permanent Stormwater Control Plan (PSC Plan). Guidance on preparing a Stormwater Site Plan is contained in Chapter 3 of Volume I.
<b>Stream gaging</b>	The quantitative determination of stream flow using gages, current meters, weirs, or other measuring instruments at selected locations. See Gaging station.
<b>Streambanks</b>	The usual boundaries, not the flood boundaries, of a stream channel. Right and left banks are named facing downstream.
<b>Streams</b>	Those areas where surface waters flow sufficiently to produce a defined channel or bed. A defined channel or bed is an area that demonstrates clear evidence of the passage of water and includes, but is not limited to , indicated by hydraulically sorted sediments or the removal of vegetative litter or loosely rooted vegetation by the action of moving water. The channel or bed need not contain water year-round. This definition is not meant to include irrigation ditches, canals, stormwater runoff devices or other entirely artificial watercourses unless they are used to convey streams naturally occurring prior to construction. Those topographic features that resemble streams but have no defined channels (i.e. swales) shall be considered streams when hydrologic and hydraulic analyses done pursuant to a development proposal predict formation of a defined channel after development.
<b>Structure</b>	A catchbasin or manhole in reference to a storm drainage system.
<b>Structural source control BMPs</b>	Physical, structural, or mechanical devices or facilities that are intended to prevent pollutants from entering stormwater. Structural source control BMPs typically include:



- Enclosing and/or covering the pollutant source (building or other enclosure, a roof over storage and working areas, temporary tarp, etc.).
- Segregating the pollutant source to prevent run-on of stormwater, and to direct only contaminated stormwater to appropriate treatment BMPs.

<b>Stub-out</b>	A short length of pipe provided for future connection to a storm drainage system.
<b>Subbasin</b>	A drainage area that drains to a water-course or waterbody named and noted on common maps and which is contained within a basin.
<b>Subcatchment</b>	A subdivision of a drainage basin (generally determined by topography and pipe network configuration).
<b>Subdrain</b>	A pervious backfilled trench containing stone or a pipe for intercepting ground water or seepage.
<b>Subgrade</b>	A layer of stone or soil used as the underlying base for a BMP.
<b>Subsoil</b>	The B horizons of soils with distinct profiles. In soils with weak profile development, the subsoil can be defined as the soil below the plowed soil (or its equivalent of surface soil), in which roots normally grow. Although a common term, it cannot be defined accurately. It has been carried over from early days when "soil" was conceived only as the plowed soil and that under it as the "subsoil."
<b>Substrate</b>	The natural soil base underlying a BMP.
<b>Surcharge</b>	The flow condition occurring in closed conduits when the hydraulic grade line is above the crown of the sewer.
<b>Surface and stormwater</b>	Water originating from rainfall and other precipitation that is found in drainage facilities, rivers, streams, springs, seeps, ponds, lakes, and wetlands as well as shallow ground water.
<b>Surface and stormwater management system</b>	Drainage facilities and any other natural features that collect, store, control, treat and/or convey surface and stormwater.
<b>Suspended solids</b>	Organic or inorganic particles that are suspended in and carried by the water. The term includes sand, mud, and clay particles (and associated pollutants) as well as solids in stormwater.
<b>Swale</b>	A shallow drainage conveyance with relatively gentle side slopes, generally with flow depths less than one foot.

<b>Terrace</b>	An embankment or combination of an embankment and channel across a slope to control erosion by diverting or storing surface runoff instead of permitting it to flow uninterrupted down the slope.
<b>Threshold Discharge Area</b>	An onsite area draining to a single natural discharge location or multiple natural discharge locations that combine within one-quarter mile downstream (as determined by the shortest flowpath). The examples in Figure 2.1 of Volume I illustrate this definition. The purpose of this definition is to clarify how the thresholds of this manual are applied to project sites with multiple discharge points.
<b>Tightline</b>	A continuous length of pipe that conveys water from one point to another (typically down a steep slope) with no inlets or collection points in between.
<b>Tile, Drain</b>	Pipe made of burned clay, concrete, or similar material, in short lengths, usually laid with open joints to collect and carry excess water from the soil.
<b>Tile drainage</b>	Land drainage by means of a series of tile lines laid at a specified depth and grade.
<b>Till</b>	A layer of poorly sorted soil deposited by glacial action that generally has very low infiltration rates.
<b>Time of concentration</b>	The time period necessary for surface runoff to reach the outlet of a subbasin from the hydraulically most remote point in the tributary drainage area.
<b>Topography</b>	General term to include characteristics of the ground surface such as plains, hills, mountains, degree of relief, steepness of slopes, and other physiographic features.
<b>Topsoil</b>	Topsoil shall be per ASTM D5268 standard specification, and water permeability shall be 0.6 inches per hour or greater. Organic matter shall have not more than 10 percent of nutrients in mineralized water-soluble forms. Topsoil shall not have phytotoxic characteristics.
<b>Total dissolved solids</b>	The dissolved salt loading in surface and subsurface waters.
<b>Total Petroleum Hydrocarbons (TPH)</b>	TPH-Gx: The qualitative and quantitative method (extended) for volatile (“gasoline”) petroleum products in water; and TPH-Dx: The qualitative and quantitative method (extended) for semi-volatile (“diesel”) petroleum products in water.
<b>Total solids</b>	The solids in water, sewage, or other liquids, including the dissolved, filterable, and nonfilterable solids. The residue left when the moisture is evaporated and the remainder is dried at a specified temperature, usually 130°C.

<b>Total suspended solids</b>	That portion of the solids carried by stormwater that can be captured on a standard glass filter.
<b>Total Maximum Daily Load (TMDL) – Water Cleanup Plan</b>	A calculation of the maximum amount of a pollutant that a waterbody can receive and still meet water quality standards, and an allocation of that amount to the pollutant's sources. A TMDL (also known as a Water Cleanup Plan) is the sum of the allowable loads of a single pollutant from all contributing point and nonpoint sources. The calculation must include a margin of safety to ensure that the waterbody can be used for the purposes the State has designated. The calculation must also account for seasonable variation in water quality. Water quality standards are set by states, territories, and tribes. They identify the uses for each waterbody, for example, drinking water supply, contact recreation (swimming), and aquatic life support (fishing), and the scientific criteria to support that use. The Clean Water Act, section 303, establishes the water quality standards and TMDL programs.
<b>Toxic</b>	Poisonous, carcinogenic, or otherwise directly harmful to life.
<b>Tract</b>	A legally created parcel of property designated for special nonresidential and noncommercial uses.
<b>Trash rack</b>	A structural device used to prevent debris from entering a spillway or other hydraulic structure.
<b>Travel time</b>	The estimated time for surface water to flow between two points of interest.
<b>Treatment BMP</b>	A BMP that is intended to remove pollutants from stormwater. A few examples of treatment BMPs are detention ponds, oil/water separators, biofiltration swales, and constructed wetlands.
<b>Treatment liner</b>	A layer of soil that is designed to slow the rate of infiltration and provide sufficient pollutant removal so as to protect groundwater quality.
<b>Treatment train</b>	A combination of two or more treatment facilities connected in series.
<b>Turbidity</b>	Dispersion or scattering of light in a liquid, caused by suspended solids and other factors; commonly used as a measure of suspended solids in a liquid.
<b>Underdrain</b>	Plastic pipes with holes drilled through the top, installed on the bottom of an infiltration BMP, which are used to collect and remove excess runoff.
<b>Undisturbed buffer</b>	A zone where development activity shall not occur, including logging, and/or the construction of utility trenches, roads, and/or surface and stormwater facilities.

<b>Undisturbed low gradient uplands</b>	Forested land, sufficiently large and flat to infiltrate surface and storm runoff without allowing the concentration of water on the surface of the ground.
<b>Unstable slopes</b>	Those sloping areas of land which have in the past exhibited, are currently exhibiting, or will likely in the future exhibit, mass movement of earth.
<b>Unusual biological community types</b>	Assemblages of interacting organisms that are relatively uncommon regionally.
<b>Urbanized area</b>	Areas designated and identified by the U.S. Bureau of Census according to the following criteria: an incorporated place and densely settled surrounding area that together have a maximum population of 50,000.
<b>U.S. EPA</b>	The United States Environmental Protection Agency.
<b>Values</b>	Wetland processes or attributes that are valuable or beneficial to society (also see Functions). Wetland values include support of commercial and sport fish and wildlife species, protection of life and property from flooding, recreation, education, and aesthetic enhancement of human communities.
<b>Variance</b>	See Exception.
<b>Vegetation</b>	All organic plant life growing on the surface of the earth.
<b>Waterbody</b>	Surface waters including rivers, streams, lakes, marine waters, estuaries, and wetlands.
<b>Water Cleanup Plan</b>	See Total Maximum Daily Load
<b>Water quality</b>	A term used to describe the chemical, physical, and biological characteristics of water, usually in respect to its suitability for a particular purpose.
<b>Water quality design storm</b>	The 24-hour rainfall amount with a 6-month return frequency. Commonly referred to as the 6-month, 24-hour storm.
<b>Water quality standards</b>	Minimum requirements of purity of water for various uses; for example, water for agricultural use in irrigation systems should not exceed specific levels of sodium bicarbonate, pH, total dissolved salts, etc. In Washington, the Department of Ecology sets water quality standards.
<b>Watershed</b>	A geographic region within which water drains into a particular river, stream, or body of water. Watersheds can be as large as those identified and numbered by the State of Washington Water Resource Inventory Areas (WRIAs) as defined in Chapter 173-500 WAC.

<b>Water table</b>	The upper surface or top of the saturated portion of the soil or bedrock layer, indicates the uppermost extent of ground water.
<b>Weir</b>	Device for measuring or regulating the flow of water.
<b>Weir notch</b>	The opening in a weir for the passage of water.
<b>Wetlands</b>	Those areas that are inundated or saturated by surface or ground water at a frequency and duration sufficient to support, and that under normal circumstances do support, a prevalence of vegetation typically adapted for life in saturated soil conditions. Wetlands generally include swamps, marshes, bogs, and similar areas. Wetlands do not include those artificial wetlands intentionally created from nonwetland sites, including, but not limited to, irrigation and drainage ditches, grass-lined swales, canals, detention facilities, wastewater treatment facilities, farm ponds, and landscape amenities, or those wetlands created after July 1, 1990, that were unintentionally created as a result of the construction of a road, street, or highway. Wetlands may include those artificial wetlands intentionally created from nonwetland areas to mitigate the conversion of wetlands. (Waterbodies not included in the definition of wetlands as well as those mentioned in the definition are still waters of the state.)
<b>Wetland edge</b>	Delineation of the wetland edge shall be based on the U.S. Army Corps of Engineers <u>Wetlands Delineation Manual</u> , Technical Report Y-87-1, U.S. Army Engineers Waterways Experiment Station, Vicksburg, Miss. (1987)
<b>Wetponds and wetvaults</b>	Drainage facilities for water quality treatment that contain permanent pools of water that are filled during the initial runoff from a storm event. They are designed to optimize water quality by providing retention time in order to settle out particles of fine sediment to which pollutants such as heavy metals absorb, and to allow biologic activity to occur that metabolizes nutrients and organic pollutants.
<b>Zoning ordinance</b>	An ordinance based on the police power of government to protect the public health, safety, and general welfare. It may regulate the type of use and intensity of development of land and structures to the extent necessary for a public purpose. Requirements may vary among various geographically defined areas called zones. Regulations generally cover such items as height and bulk of buildings, density of dwelling units, off-street parking, control of signs, and use of land for residential, commercial, industrial, or agricultural purposes. A zoning ordinance is one of the major methods for implementation of a comprehensive plan.

# **City of Tacoma Surface Water Management Manual**

---

## **Volume II Construction Stormwater Pollution Prevention**

Prepared by:

Tacoma Public Works  
Environmental Services

January 2003



# Table of Contents – Volume II

---

<b>Chapter 1 – Introduction to Construction Stormwater Pollution Prevention.....</b>	<b>1-1</b>
1.1 Purpose of this Volume.....	1-1
1.2 Content and Organization of this Volume.....	1-2
1.3 How to Use this Volume.....	1-2
1.4 Twelve Elements of Construction Stormwater Pollution Prevention .....	1-3
1.5 Erosion and Sedimentation Impacts.....	1-3
1.6 Erosion and Sedimentation Processes .....	1-4
1.6.1 Soil Erosion.....	1-4
1.6.2 Sedimentation .....	1-5
1.7 Factors Influencing Erosion Potential.....	1-5
1.7.1 Soil Characteristics.....	1-6
1.7.2 Vegetative Cover.....	1-7
1.7.3 Topography.....	1-7
1.7.4 Climate.....	1-7
<b>Chapter 2 – Regulatory Requirements .....</b>	<b>2-1</b>
2.1 Ecology’s NPDES Stormwater Permits .....	2-1
2.1.1 Ecology’s General Permit for Stormwater Discharges Associated with Construction Activities .....	2-2
2.1.2 Construction Stormwater Pollution Prevention Plan.....	2-4
2.2 Water Quality Standards.....	2-4
2.2.1 Surface Water Quality Standards .....	2-4
2.2.2 Compliance with Standards.....	2-5
2.3 Endangered Species Act.....	2-6
2.4 Other Applicable Regulations and Permits.....	2-6
<b>Chapter 3 – Planning .....</b>	<b>3-1</b>
3.1 General Guidelines .....	3-1
3.1.1 What is a Construction Stormwater Pollution Prevention Plan? .....	3-1
3.1.2 What is an Adequate Plan? .....	3-2
3.1.3 BMP Standards and Specifications.....	3-2
3.1.4 General Principles.....	3-3



3.2	Step-By-Step Procedure .....	3-3
3.2.1	Step 1 – Data Collection .....	3-4
3.2.2	Step 2 – Data Analysis .....	3-5
3.2.3	Step 3 – Construction SWPPP Development and Implementation.....	3-6
3.3	Checklists for Construction SWPPPs .....	3-15
3.3.1	Narrative.....	3-15
3.3.2	Drawings .....	3-16
<b>Chapter 4 – Standards and Specifications for Best Management Practices .....</b>		<b>4-1</b>
4.1	Source Control BMPs .....	4-2
	BMP C101: Preserving Natural Vegetation .....	4-2
	BMP C102: Buffer Zones .....	4-5
	BMP C103: High Visibility Plastic or Metal Fence.....	4-6
	BMP C104: Stake and Wire Fence .....	4-7
	BMP C105: Stabilized Construction Entrance .....	4-8
	BMP C106: Wheel Wash .....	4-10
	BMP C107: Construction Road/Parking Area Stabilization .....	4-11
	BMP C120: Temporary and Permanent Seeding .....	4-12
	BMP C121: Mulching .....	4-17
	BMP C122: Nets and Blankets.....	4-18
	BMP C123: Plastic Covering .....	4-21
	BMP C124: Sodding .....	4-23
	BMP C125: Topsoiling .....	4-24
	BMP C126: Polyacrylamide for Soil Erosion Protection.....	4-27
	BMP C130: Surface Roughening .....	4-30
	BMP C131: Gradient Terraces .....	4-31
	BMP C140: Dust Control.....	4-33
	BMP C150: Materials On Hand .....	4-35
	BMP C151: Concrete Handling.....	4-36
	BMP C152: Sawcutting and Surfacing Pollution Prevention .....	4-37
	BMP C160: Contractor Erosion and Spill Control Lead .....	4-38
	BMP C161: Payment of Erosion Control Work .....	4-40
	BMP C162: Scheduling .....	4-42
	BMP C180: Small Project Construction Stormwater Pollution Prevention ....	4-43

4.2	Runoff Conveyance and Treatment BMPs .....	4-44
	BMP C200: Interceptor Dike and Swale .....	4-44
	BMP C201: Grass-Lined Channels .....	4-46
	BMP C202: Channel Lining .....	4-48
	BMP C203: Water Bars.....	4-50
	BMP C204: Pipe Slope Drains .....	4-52
	BMP C205: Subsurface Drains .....	4-55
	BMP C206: Level Spreader .....	4-57
	BMP C207: Check Dams .....	4-59
	BMP C208: Triangular Silt Dike (Geotextile-Encased Check Dam).....	4-61
	BMP C209: Outlet Protection .....	4-62
	BMP C220: Storm Drain Inlet Protection .....	4-64
	BMP C230: Straw Bale Barrier.....	4-67
	BMP C231: Brush Barrier.....	4-69
	BMP C232: Gravel Filter Berm.....	4-70
	BMP C233: Silt Fence.....	4-71
	BMP C234: Vegetated Strip .....	4-75
	BMP C235: Straw Wattles.....	4-76
	BMP C240: Sediment Trap .....	4-78
	BMP C241: Temporary Sediment Pond .....	4-81
	BMP C250: Construction Stormwater Chemical Treatment.....	4-85
	BMP C251: Construction Stormwater Filtration .....	4-90
	<b>Resource Materials .....</b>	<b>R-1</b>

## Appendices

Appendix II-A	Recommended Standard Notes for Erosion Control Plans
Appendix II-B	Background Information on Chemical Treatment
Appendix II-C	Small Site Educational Hand-Out
Appendix II-D	Construction SWPPP Short Form

## Tables

4.1	Temporary Erosion Control Seed Mix .....	4-92
4.2	Landscaping Seed Mix .....	4-92
4.3	Low-Growing Turf Seed Mix .....	4-92
4.4	Bioswale Seed Mix .....	4-92
4.5	Wet Area Seed Mix.....	4-93
4.6	Meadow Seed Mix .....	4-93
4.7	Mulch Standards and Guidelines .....	4-94
4.8	PAM and Water Application Rates.....	4-95
4.9	Storm Drain Inlet Protection.....	4-95
4.10	Geotextile Standards .....	4-96
4.11	Vegetated Strips.....	4-96

## Figures

1-1	Types of Erosion .....	1-9
1-2	Factors Influencing Erosion Potential .....	1-9
4-1	Stake and Wire Fence .....	4-97
4-2	Stabilized Construction Entrance.....	4-97
4-3	Wheel Wash .....	4-98
4-4	Channel Installation .....	4-99
4-5	Slope Installation .....	4-99
4-6	PAM and Water Application Rates.....	4-100
4-7	Surface Roughening by Tracking and Contour Furrows .....	4-101
4-8	Gradient Terraces .....	4-102
4-9	Typical Grass-Lined Channels.....	4-102
4-10	Temporary Channel Liners .....	4-103
4-11	Pipe Slope Drains.....	4-104
4-12	Cross Section of Level Spreader .....	4-104
4-13	Detail of Level Spreader .....	4-104
4-14	Check Dams.....	4-105
4-15	Block and Gravel Filter .....	4-106
4-16	Block and Gravel Curb Inlet Protection .....	4-107
4-17	Curb and Gutter Barrier .....	4-108

4-18	Straw Bale Barrier .....	4-109
4-19	Brush Barrier .....	4-110
4-20	Silt Fence .....	4-110
4-21	Silt Fence Installation by Slicing Method.....	4-111
4-22	Straw Wattles .....	4-112
4-23	Cross-Section of Sediment Trap.....	4-113
4-24	Sediment Trap Outlet .....	4-113
4-25	Sediment Pond Plan View .....	4-113
4-26	Sediment Pond Cross Section.....	4-114
4-27	Sediment Pond Riser Detail.....	4-114
4-28	Riser Inflow Curves .....	4-115

# Chapter 1 – Introduction to Construction Stormwater Pollution Prevention

---

## 1.1 Purpose of this Volume

Volume II of this Surface Water Management Manual is entirely devoted to surface water effects and controls associated with construction activities. It addresses the planning, design, and implementation of surface water management activities prior to and during the construction phase of projects.

The objective of this volume is to provide guidance for avoiding adverse surface water impacts from construction activities on downstream resources and on-site surface water facilities. Minimization of surface water flows, prevention of soil erosion, capture of water-borne sediment that has been unavoidably released from exposed soils, and protection of water quality from on-site pollutant sources are all readily achievable when the proper Best Management Practices (BMPs) are planned, installed, and properly maintained.

Initial discussions between the project proponents and their designer, contractors, and compliance inspectors can identify approaches to accomplishing a high quality, cost-effective project without compromising environmental protection. Often new ways are found to stage, time, and phase parts of a project to economize a contractor's schedule and use of construction materials. This collaborative planning process can produce methods to minimize or eliminate vulnerability and unnecessary risk associated with some traditional construction practices and techniques.

The construction phase of a project is usually considered a temporary condition, which will be supplanted by the permanent improvements and facilities for the completed project. However, construction work may take place over an extended period of time, including several seasons of multiple years. All management practices and control facilities used in the course of construction should be of sufficient size, strength, and durability to readily outlast the longest possible construction schedule and the worst anticipated rainfall conditions.

Linear projects, such as roadway construction and utility installations, are special cases of construction activities and present their own, unique set of surface water protection challenges. Many of the BMPs can be adapted and modified to provide the controls needed to adequately address these projects. It may be advantageous to segment long, linear projects into a series of separate units that can apply all necessary controls pertinent to that particular unit in a timely manner.

The goal of a Construction Stormwater Pollution Prevention Plan (SWPPP) is to avoid immediate and long-term environmental loss and degradation typically caused by poorly managed construction sites. Prompt implementation of a Construction SWPPP, designed in accordance with Chapters 3 and 4 of this volume, can provide a number

of benefits. These include minimizing construction delays, reducing resources spent on repairing erosion, improving the relationship between the contractor and the permitting authority, and limiting adverse effects on the environment.

Many of the BMPs contained in this volume can be adapted and modified to provide the erosion and sediment controls needed for other activities such as mining.

## **1.2 Content and Organization of this Volume**

Volume II consists of four chapters that address the key considerations and mechanics of preparing and implementing Construction SWPPPs.

Chapter 1 highlights the importance of construction surface water management in preventing pollution of surface waters. The chapter briefly lists 12 elements of pollution prevention to be considered for all projects. The elements are fully detailed later in this volume. Erosion and sedimentation processes and impacts are discussed.

Chapter 2 contains the regulatory requirements that apply to construction sites and their surface water discharges. The Department of Ecology's (Ecology) National Pollutant Discharge Elimination System (NPDES) discharge permit and municipal construction site runoff control programs are discussed. Chapter 2 lists Washington's Water Quality Standards pertaining to construction surface water and explains how they apply to field situations.

Chapter 3 presents a step-by-step method for developing a Construction SWPPP. It encourages examination of all possible conditions that could reasonably affect a particular project's surface water control systems during the construction phase of the project.

Chapter 4 contains BMPs for construction surface water control and site management. The first section of Chapter 4 contains BMPs for Source Control. The second section addresses runoff, conveyance, and treatment BMPs. Various combinations of these BMPs should be used in the Construction SWPPP to satisfy each of the 12 elements applying to the project.

## **1.3 How to Use this Volume**

This volume should be used in developing the Construction Stormwater Pollution Prevention Plan, which is a required component of a Stormwater Site Plan (see Volume I, Chapter 4). Users should refer to this introductory chapter for an overview of construction surface water issues, particularly related to erosion and sedimentation. Chapter 2 should be consulted to determine the regulatory requirements that apply to a construction site, including permit requirements that deal with surface water at construction sites. Users should read Chapter 3 to determine the organization and content of the Construction SWPPP. This chapter includes lists of suggested BMPs to meet each element of construction surface water pollution prevention. Based on these lists, the project

proponent should refer to Chapter 4 to determine which BMPs will be included in the Construction SWPPP, and to design and document application of these BMPs to the project construction site.

## **1.4 Twelve Elements of Construction Stormwater Pollution Prevention**

The 12 elements listed below must be considered in the development of the Construction SWPPP unless site conditions render the element unnecessary. If an element is considered unnecessary, the Construction SWPPP must provide the justification.

These elements cover the general water quality protection strategies of limiting site impacts, preventing erosion and sedimentation, and managing activities and sources.

The 12 elements are:

- Mark Clearing Limits
- Establish Construction Access
- Control Flow Rates
- Install Sediment Controls
- Stabilize Soils
- Protect Slopes
- Protect Drain Inlets
- Stabilize Channels and Outlets
- Control Pollutants
- Control Dewatering
- Maintain BMPs
- Manage the Project

A complete description of each element and associated BMPs is given in Chapter 3.

## **1.5 Erosion and Sedimentation Impacts**

Soil erosion and the resulting sedimentation produced by land development impacts the environment, damaging aquatic and recreational resources as well as aesthetic qualities. Erosion and sedimentation ultimately affect everyone.

Common examples of the impacts of erosion and sedimentation are:

- Natural, nutrient rich topsoils are eroded away, making re-establishment of vegetation difficult. Consequently, soil amendments and fertilizers must be applied. A properly functioning soil system is a sustained surface water management mechanism. Vegetation and soil are not effectively sustained unless both are maintained in good condition.
- Siltation fills culverts and storm drains, decreasing capacities and increasing flooding and maintenance frequency.

- Detention facilities fill rapidly with sediment, decreasing storage capacity and increasing flooding.
- Infiltration devices become clogged and fail.
- Streams and harbors must be dredged to remove obstructions caused by sedimentation in order to restore navigability.
- Sediment in lakes builds more rapidly. Resulting shallow areas become covered by aquatic plants, reducing usability. Increased nutrient loading from phosphorus attached to soil particles and transported to lakes and streams can cause a change in the water pH, algal blooms and oxygen depletion that lead to eutrophication and fish kills.
- Treatment of water for domestic uses becomes more difficult and costly.
- Aesthetically pleasing, clear, clean water is replaced with turbid water in streams and lakeshores.
- Eroded soil particles decrease the viability of macro-invertebrates and food-chain organisms, impair the feeding ability of aquatic animals, clog gill passages of fish, and reduce photosynthesis.
- Successful fish spawning is diminished by sediment-clogged gravel. Sedimentation following spawning can smother the eggs or young fry.

Costs associated with these impacts can be obvious or subtle. Some are difficult to quantify, such as the loss of aesthetic values or recreational opportunities. Restoration and management of a single lake can cost millions of dollars. Reductions in spawning habitat, and subsequent reduction in salmon and trout production, cause economic losses to sports fisheries and traditional Native American fisheries. The maintenance costs of man-made structures and harbors are readily quantifiable. Citizens pay repeatedly for these avoidable costs as city, county, state, and federal taxpayers.

Effective erosion and sediment control practices on construction sites can greatly reduce undesirable environmental impacts and costs. Being aware of the erosion and sedimentation process is helpful in understanding the role of BMPs in controlling surface water runoff.

## **1.6 Erosion and Sedimentation Processes**

### **1.6.1 Soil Erosion**

Soil erosion is defined as the removal of soil from its original location by the action of water, ice, gravity, or wind. In construction activities, soil erosion is largely caused by the force of falling and flowing water. Erosion by water includes the following processes (see Figure 1.1):

- Raindrop Erosion: The direct impact of falling drops of rain on soil dislodges soil particles so that they can then be easily transported by runoff.



- **Sheet Erosion:** The removal of a layer of exposed soil by the action of raindrop splash and runoff, as water moves in broad sheets over the land and is not confined in small depressions.
- **Rill and Gully Erosion:** As runoff concentrates in rivulets, it cuts grooves called rills into the soil surface. If the flow of water is sufficient, rills may develop into larger gullies.
- **Stream and Channel Erosion:** Increased volume and velocity of runoff in an unprotected, confined channel may cause stream meander instability and scouring of significant portions of the stream or channel banks and bottom.

Soil erosion by wind creates a water quality problem when dust is blown into water. Dust control on paved streets using washdown waters, if not conducted properly, can also create water quality problems.

### **1.6.2 Sedimentation**

Sedimentation is defined as the gravity-induced settling of soil particles transported by water. The process is accelerated in slower-moving, quiescent stretches of natural waterbodies or in treatment facilities such as sediment ponds and wetponds.

Sedimentation occurs when the velocity of water in which soil particles are suspended is slowed for a sufficient time to allow particles to settle. The settling rate is dependent on the soil particle size. Heavier particles, such as sand and gravel, can settle more rapidly than fine particles such as clay and silt. Sedimentation of clay soil particles is reduced due to clay's relatively low density and electro-charged surfaces, which discourage aggregation. The presence of clay particles in surface water runoff can result in highly turbid water, which is not amenable to treatment by settling.

Turbidity, an indirect measure of soil particles in water, is one of the primary water quality standards in Washington State law (WAC 173-201A-030). Turbidity is increased when erosion carries soil particles into receiving waters. Treating surface water to reduce turbidity can be an expensive, difficult process with limited effectiveness. Any actions or prevention measures that reduce the volume of water needing treatment for turbidity are beneficial.

## **1.7 Factors Influencing Erosion Potential**

The erosion potential of soils can be readily determined using various models such as the Flaxman Method or the Revised Universal Soil Loss Equation (RUSLE).

The soil erosion potential of an area, including a construction site, is determined by four interrelated factors (see Figure 1.2):

- Soil characteristics
- Vegetative cover
- Topography
- Climate

Collection, analysis, and use of detailed information specific to the construction site for each of these four factors can provide the basis for an effective construction surface water management system.

The first three factors, soil characteristics, vegetative cover, and topography are constant with respect to time until altered intentionally by construction. The designer, developer, and construction contractor should have a working knowledge about and control over these factors to provide high quality surface water results.

The fourth factor, climate, is predictable by season, historical record, and probability of occurrence. While predicting a rainfall event is not possible, many of the impacts of construction surface water runoff can be minimized or avoided by planning appropriate seasonal construction activity and using properly designed BMPs.

#### 1.7.1 Soil Characteristics

The vulnerability of soil to erode is determined by soil characteristics: particle size, organic content, soil structure, and soil permeability.

- **Particle Size** - Soils that contain high proportions of silt and very fine sand are generally the most erodible and are easily detached and carried away. The erodibility of soil decreases as the percentage of clay or organic matter increases; clay acts as a binder and tends to limit erodibility. Most soils with high clay content are relatively resistant to detachment by rainfall and runoff. Once eroded, however, clays are easily suspended and settle out very slowly.
- **Organic Content** - Organic matter creates a favorable soil structure, improving its stability and permeability. This increases infiltration capacity, delays the start of erosion, and reduces the amount of runoff. The addition of organic matter increases infiltration rates (and, therefore, reduces surface flows and erodibility), water retention, pollution control, and pore space for oxygen.
- **Soil Structure** - Organic matter, particle size, and gradation affect soil structure, which is the arrangement, orientation, and organization of particles. When the soil system is protected from compaction, the natural decomposition of plant debris on the surface maintains a healthy soil food web. The soil food web in turn maintains the porosity both on and below the surface.

- **Soil Permeability** - Soil permeability refers to the ease with which water passes through a given soil. Well-drained and well-graded gravel and gravel mixtures with little or no silt are the least erodible soils. Their high permeability and infiltration capacity helps prevent or delay runoff.

### 1.7.2 Vegetative Cover

Vegetative cover plays an extremely important role in controlling erosion by:

- Shielding the soil surface from the impact of falling rain.
- Slowing the velocity of runoff, thereby permitting greater infiltration.
- Maintaining the soil's capacity to absorb water through root zone uptake and evapotranspiration.
- Holding soil particles in place.

Erosion can be significantly reduced by limiting the removal of existing vegetation and by decreasing duration of soil exposure to rainfall events. Give special consideration to the preservation of existing vegetative cover on areas with a high potential for erosion such as erodible soils, steep slopes, drainage ways, and the banks of streams. When it is necessary to remove vegetation, such as for noxious weed eradication, revegetate these areas immediately.

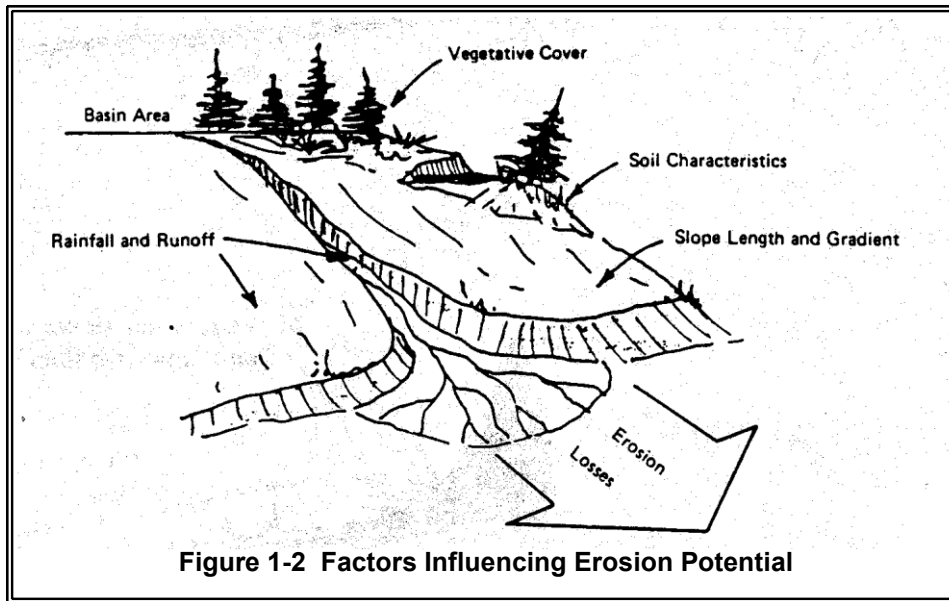
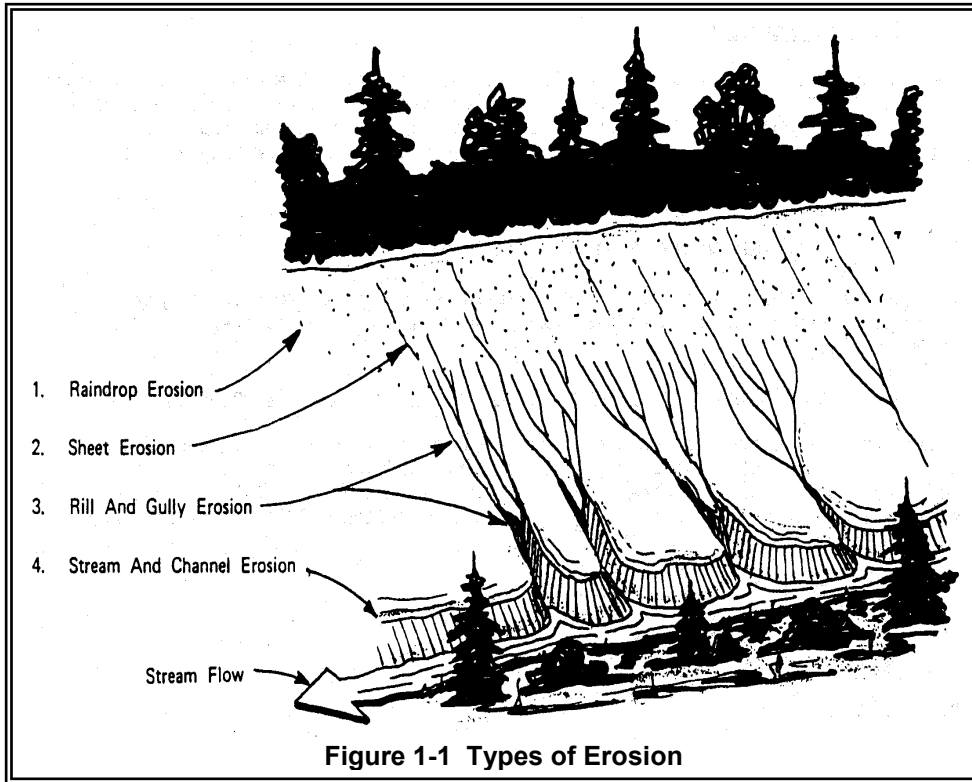
### 1.7.3 Topography

The size, shape, and slope of a construction site influence the amount and rate of surface water runoff. Each site's unique dimensions and characteristics provide both opportunities for and limitations on the use of specific control measures to protect vulnerable areas from high runoff amounts and rates. Slope length, steepness, and surface texture are key elements in determining the volume and velocity of runoff. As slope length and/or steepness increase the rate of runoff and the potential for erosion increases. Slope orientation is also a factor in determining erosion potential. For example, a slope that faces south and contains drought soils may provide such poor growing conditions that vegetative cover will be difficult to re-establish.

### 1.7.4 Climate

Seasonal temperatures and the frequency, intensity, and duration of rainfall are fundamental factors in determining amounts of runoff. As the volume and the velocity of runoff increase, the likelihood of erosion increases. Where storms are frequent, intense, or of long duration, erosion risks are high. Seasonal changes in temperature, as well as variations in rainfall, help to define the period of the year when there is a high erosion risk. When precipitation falls as snow, no erosion occurs. In the spring, melting snow adds to the runoff, and erosion potential will be higher. If the ground is still partially frozen, infiltration capacity is reduced. Rain-on-snow events are common in western Washington between 1,500 and 3,000-foot elevation.

Western Washington is characterized in fall, winter, and spring by storms that are mild and long lasting. The fall and early winter events saturate the soil profile and fill surface water detention ponds, increasing the amount of runoff leaving the construction site. Shorter-term, more intense storms occur in the summer. These storms can cause problems if adequate BMPs have not been installed on-site.



## Chapter 2 - Regulatory Requirements

---

Construction site surface water runoff is regulated on the local level and at the State level.

- Phase I National Pollutant Discharge Elimination System (NPDES) municipal permits require large urban cities and counties, including Tacoma, to adopt development regulations implementing controls for new development and redevelopment, including measures for control of erosion, sedimentation, and other pollutants on construction sites.
- The Phase II NPDES municipal permit program will require many municipalities throughout the state to adopt development regulations implementing controls for new development and redevelopment, including measures for control of erosion, sedimentation, and other pollutants on construction sites.
- Construction projects must apply for coverage under Ecology's NPDES General Permit for Stormwater Associated with Construction Activities if the project:
  - Results in the disturbance of five acres or more of land, including clearing, grading, and excavation activities, and
  - Discharges surface water from the site into a surface water or discharge to a storm drain system that discharges to a surface water.
- Some construction projects may require an individual Ecology NPDES permit.
- Beginning in 2003, coverage under Ecology's General Permit will be required for construction sites that result in the disturbance of one acre or more of land.

### 2.1 Ecology's NPDES Stormwater Permits

Section 402(p)(4) of the Clean Water Act clarifies the requirement for EPA and delegated state agencies to issue NPDES permits for surface water discharges associated with industrial activity. The federal regulations require an NPDES permit for listed industrial facilities and those construction activities which will disturb five or more acres of land, that discharge "stormwater associated with industrial activities" directly to surface waters, or indirectly through municipal storm drains. The regulations include a definition of "stormwater associated with industrial activity," and a listing of application requirements for surface water permits.

Designated industries that discharge surface water are required to apply for coverage under Ecology's Baseline General Permit for Stormwater Discharges Associated with Industrial Activities (the Industrial General Permit). Facilities that only discharge surface water runoff from administrative building roofs and employee parking lots are not required to obtain permit coverage. Industrial facilities may qualify for a waiver

(conditional exemption) if they can demonstrate that there will be no exposure of industrial materials and activities to surface water.

### **2.1.1 Ecology's General Permit for Stormwater Discharges Associated with Construction Activities**

Coverage under Ecology's Construction General Permit is required for any clearing, grading, or excavating that will disturb five acres or more of land area and that will discharge surface water from the site into surface water(s), or into storm drainage systems that discharge to a surface water. Parcels less than five acres in area that are part of a common plan of development totaling five acres or more are also required to obtain a permit. Under the Phase II NPDES regulations, the acreage trigger will be reduced from five acres to one acre in March 2003.

For construction of subdivisions, the five-acre threshold that triggers the permit requirements applies only to land that is disturbed by the landowner, the landowner's representative, or a contractor to the landowner. If the owner or the owner's representative or contractor is only installing roads and utilities, only land disturbed for that construction should be calculated to determine whether the five-acre threshold would be exceeded. Land to be disturbed by independent contractors who purchase lots from the owner should not be considered when deciding the owner's responsibilities, unless the individual lots are disturbed prior to being sold; for example by clearing and grading. However, if an independent contractor has purchased contiguous individual lots that will disturb a total of five acres or more, the contractor must obtain coverage under the Construction General Permit.

Any construction activity discharging surface water that Ecology and/or the City determine to be a significant contributor of pollutants to waters of the state may be required to have permit coverage regardless of project size.

#### **Applicants for coverage under the Construction General Permit must do the following:**

- ***File a Notice of Intent (application for coverage)***

The permit application, called a Notice of Intent (NOI), shall be submitted to Ecology before the date of the first public notice and at least 38 days prior to the start of construction.

- ***Publish a Public Notice***

At the time of application, the applicant must publish a notice that they are seeking coverage under Ecology's general stormwater permit for construction activities. This notice must be published at least once each week for two consecutive weeks in a single newspaper that has general circulation in the county in which the construction is to take place. Refer to the NOI instructions for public notice language requirements. State law requires a 30-day public comment period prior to permit coverage; therefore, permit coverage will not be granted sooner than 31 days after the date of the last public notice.

- **Prepare a Construction Stormwater Pollution Prevention Plan**

Permit coverage will not be granted until the permittee has indicated completion of the SWPPP or certified that development of a SWPPP in accordance with Special Condition S9 of the permit will occur prior to the commencement of construction. SWPPPs are not submitted to Ecology but retained on site or within reasonable access to the site to be made available to Ecology and local government agencies upon request.

Applicants who discharge surface water associated with construction activity to a storm drain operated by any of the following municipalities are also required to submit a copy of the NOI to the municipality:

Seattle, King County, Snohomish County, Tacoma, Pierce County, Clark County, Spokane County, and Washington Department of Transportation (WSDOT), if discharge occurs within these permit areas.

Because Ecology has determined that a local manual may be used where the local requirements for construction sites are at least as stringent as Ecology's, applicants should be able to prepare one construction SWPPP under the City's manual to satisfy both the Ecology permit, and City of Tacoma permits.

Construction activities that are not required to apply for coverage include:

- Construction activities that discharge surface water only to the ground and have no point source discharge to surface water or a municipal storm sewer at any time during construction;
- Any part of a facility with a surface water discharge resulting from remedial action under an order or consent decree;
- Any emergency construction activity required to protect public health and safety; and
- Any construction activity for routine maintenance of existing facilities to maintain original line and grade, or hydraulic capacity.

Facilities excluded from coverage include:

- Nonpoint source silvicultural activities;
- Construction projects that are federally owned or operated or are on tribal land, or discharge surface water directly to tribal waters with EPA approved water quality standards;
- Surface water discharges that originate from the site after construction has been completed and the site has undergone final stabilization. Final stabilization means the completion of all soil disturbing activities at the site and the establishment of a permanent vegetative cover, or equivalent permanent stabilization measures such as riprap, gabions, or geotextiles which will prevent erosion; and



- Any facility covered under an existing NPDES individual or general permit in which surface water management or treatment requirements or both are included for all surface water discharges associated with construction activity.

### **2.1.2 Construction Stormwater Pollution Prevention Plan**

Facilities covered under the Construction General Permit must prepare and implement a Construction SWPPP. The Construction SWPPP must consist of and make provisions for:

- Erosion prevention and sediment control, and
- Control of other pollutants.

The Construction SWPPP must describe construction practices, stabilization techniques, and structural BMPs that are to be implemented to prevent erosion and minimize sediment transport. Erosion prevention, sediment control, and pollution control BMP guidance and design criteria are provided in Chapter 3 and Chapter 4 of this volume.

BMPs shall be inspected, maintained, and repaired as needed to assure continued performance of their intended function. Reports summarizing the scope of inspections, the personnel conducting the inspection, the date(s) of the inspection, major observations relating to the implementation of the Construction SWPPP, and actions taken as a result of these inspections shall be prepared and retained as part of the Construction SWPPP.

## **2.2 Water Quality Standards**

### **2.2.1 Surface Water Quality Standards**

“Numerical” water quality criteria are numerical values set forth in the state of Washington's Water Quality Standards for Surface Waters (Chapter 173-201A WAC). They specify the levels of pollutants allowed in receiving waters that are protective of aquatic life.

EPA has promulgated 91 numeric water quality criteria for the protection of human health that are applicable to Washington State (EPA 1992). These criteria are designed to protect humans from cancer and other disease and are primarily applicable to fish and shellfish consumption and drinking water obtained from surface waters.

In addition to numerical criteria, "narrative" water quality criteria (WAC 173-201A-030, -040, and -050) limit concentrations of toxic, radioactive, or deleterious material below those that have the potential to adversely affect characteristic water uses, cause acute or chronic toxicity to biota, impair aesthetic values, or adversely affect human health. Narrative criteria protect the specific beneficial uses of fresh (WAC 173-201A-130) and marine (WAC 173-201A-140) waters in the state of Washington.

Pollutants that might be expected in the discharge from construction sites are turbidity, pH, and petroleum products. The surface water quality standards for turbidity and pH for Class AA (extraordinary) waters are:

**Turbidity** shall not exceed 5 nephelometric turbidity units (NTU) over background turbidity when the background turbidity is 50 NTU or less, or have more than a 10 percent increase in turbidity when the background turbidity is more than 50 NTU.

**pH** shall be within the range of 6.5 to 8.5 (freshwater) or 7.0 to 8.5 (marine water) with a human-caused variation within a range of less than 0.2 units. For Class A and lower water classifications, the permissible induced increase is 0.5 units.

Although there is no specific surface or ground water quality standard for petroleum products, the narrative surface water quality criteria prohibits any visible sheen.

The ground water quality criteria require protection from contamination in order to support the beneficial uses of the ground water, such as for drinking water. Therefore, the primary water quality consideration for surface water discharges to ground water from construction sites are the control of contaminants other than sediment. Sediment control is necessary to protect permanent infiltration facilities from clogging during the construction phase.

### **2.2.2 Compliance with Standards**

Surface water discharges associated with construction activity are subject to applicable state water quality standards. The Construction General Permit does not authorize the violation of those standards. Ecology expects that the selection and implementation of appropriate BMPs outlined in this volume of the Surface Water Management Manual (SWMM) or equivalent manuals will result in compliance with standards for surface water discharges from construction sites. Proper implementation and maintenance of these controls is critical to adequately control any adverse water quality impacts from construction activity.

Surface water discharges from construction sites must comply with Washington State's Surface Water Quality Standards (Chapter 173-201A WAC), Sediment Management Standards (Chapter 173-204 WAC), Ground Water Quality Standards (Chapter 173-200 WAC), and human health based criteria in the National Toxics Rule (Federal Register, Vol. 57, No. 246, Dec. 22, 1992, pages 60848-60923).

Compliance with standards means:

- An adequate SWPPP has been prepared and fully implemented;
- The SWPPP and its implementation are adequate to prevent the discharge of toxic pollutants, floating materials, and sediment; and

- All known, available and reasonable means (AKART) have been taken to prevent the discharge of settleable solids and to reduce turbidity in direct and indirect discharges to surface waters.

In determining compliance, Ecology will consider:

- Weather conditions as related to design storms for BMPs;
- Available dilution and background conditions in the receiving water if the SWPPP and its implementation are determined adequate. Mixing zones may be allowed through individual NPDES permits per WAC 173-201A-100; and
- Other requirements of Chapters 173-200 WAC, 173-201A WAC, and 173-204 WAC.
- The point of compliance for the water quality standards is in the surface receiving water body or in the groundwater.

## 2.3 Endangered Species Act

The Endangered Species Act (ESA) is of concern for construction sites because of the potential adverse impacts to receiving waters from discharges of sediment, turbidity, or abnormal pH. Specific adverse impacts may include:

- Suffocation of eggs or fry;
- Displacement and elimination of aquatic invertebrates utilized for food;
- Reduction in the biodiversity of aquatic invertebrates;
- Reduction of foraging abilities in turbid water;
- Irritation of gill tissue that can lead to disease or death;
- Filling of resting, feeding areas, or spawning gravels with sediment; and
- Stranding of listed species behind erosion and sediment control features or the impairment of their access into certain areas due to the presence of erosion and sediment control features

For more information on ESA and how it affects your project, please contact the National Marine Fisheries Service at: <http://www.nwr.noaa.gov/1salmon/salmesa/index.htm> or the U.S. Fish and Wildlife Service at: <http://endangered.fws.gov/endspp.html>

## 2.4 Other Applicable Regulations and Permits

In addition to City of Tacoma regulations, other regulations and permits may require the implementation of BMPs to control pollutants in construction site surface water runoff. They include:

- Project level requirements in a cleanup plan or Waste Load Allocation (WLA) that implements a Total Maximum Daily Load (TMDLs).

- Hydraulic Project Approval Permits.
- General provisions from the WSDOT.
- Contaminated site remediation agreements.

See Volume I, Section 1.6 for further information on these regulations and permits.

# Chapter 3 - Planning

---

This chapter provides an overview of the important components of, and the process for, developing and implementing a Construction Stormwater Pollution Prevention Plan (SWPPP).

Section 3.1 contains general guidelines with which site planners should become familiar. It describes criteria for plan format and content and ideas for improved plan effectiveness.

Section 3.2 outlines and describes a recommended step-by-step procedure for developing a Construction SWPPP from data collection to finished product. This procedure is written in general terms to be applicable to all types of projects.

Section 3.3 includes a checklist for developing a Construction SWPPP.

Design standards and specifications for Best Management Practices (BMPs) referred to in this chapter are found in Chapter 4.

The Construction SWPPP may be a subset of the Stormwater Site Plan or construction plan set. Full details on how to integrate the Construction SWPPP with a Stormwater Site Plan are provided in Volume 1.

## 3.1 General Guidelines

### 3.1.1 What is a Construction Stormwater Pollution Prevention Plan?

The Construction SWPPP is a document that describes the potential for pollution problems on a construction project. The Construction SWPPP explains and illustrates the measures to be taken on the construction site to control those problems. A Construction SWPPP for projects that add or replace 2,000 square feet or more of impervious surface or clear more than 7,000 square feet must have a narrative as well as drawings and details. The City will review the Construction SWPPPs for compliance and adequacy in controlling surface water during construction. Single-family home construction projects may prepare a simpler Construction SWPPP, consisting of a checklist and a plot plan, see Appendix II-C.

While it is a good idea to include standards and specifications from the Construction SWPPP in the contract documents, the Construction SWPPP should be a separate document that can stand-alone. The Construction SWPPP must be located on the construction site or within reasonable access to the site for construction and inspection personnel, although a copy of the drawings must be kept on the construction site at all times. As site work progresses, the plan must be modified to reflect changing site conditions, subject to the rules for plan modification by the City.

The owner or lessee of the land being developed has the responsibility for Construction SWPPP preparation and submission to the City. The owner or lessee may designate someone (i.e., an engineer, architect, contractor, etc.) to prepare the Construction SWPPP, but he/she retains the ultimate responsibility.

### **3.1.2 What is an Adequate Plan?**

The Construction SWPPP for projects adding or replacing 2,000 square feet or more of impervious surface or clearing 7,000 square feet or more must contain sufficient information to satisfy the City that the problems of pollution have been adequately addressed for the proposed project. An adequate Construction SWPPP includes a narrative and drawings. The narrative is a written statement to explain and justify the pollution prevention decisions made for a particular project. The narrative contains concise information about existing site conditions, construction schedules, and other pertinent items that are not contained on the drawings. The drawings and notes describe where and when the various BMPs should be installed, the performance the BMPs are expected to achieve, and actions to be taken if the performance goals are not achieved.

On construction sites that discharge to surface water, the primary concern in the preparation of the Construction SWPPP is impacts to surface water, groundwater, and sediment quality. Each of the 12 elements must be included in the Construction SWPPP unless an element is determined not to be applicable to the project and the exemption is justified in the narrative. The step-by-step procedure outlined in Section 3.2 of this volume is recommended for the development of the Construction SWPPPs. The checklists in Section 3.3 may be helpful in preparing and reviewing the Construction SWPPP.

On construction sites that infiltrate all surface water runoff, the primary concern in the preparation of the Construction SWPPP is the protection of the infiltration facilities from fine sediments during the construction phase and protection of groundwater from other pollutants. Several of the other elements are very important at these sites as well, such as marking the clearing limits, establishing the construction access, and managing the project.

### **3.1.3 BMP Standards and Specifications**

Chapter 4 contains standards and specifications for the BMPs referred to in this Chapter. Wherever any of these BMPs are to be employed on a site, the specific title and number of the BMP should be clearly referenced in the narrative and marked on the drawings.

The standards and specifications in Chapter 4 of this volume are not intended to limit any innovative or creative effort to effectively control erosion and sedimentation. In those instances where appropriate BMPs are not in this chapter, experimental management practices can be considered. Minor modifications to standard practices may also be

employed. However, such practices must be approved by the City before they may be used. All experimental management practices and modified standard practices are required to achieve the same or better performance than the BMPs listed in Chapter 4.

### **3.1.4 General Principles**

The following general principles should be applied to the development of the Construction SWPPP.

- The duff layer, native topsoil, and natural vegetation should be retained in an undisturbed state to the maximum extent practicable.
- Prevent pollutant release. Select source control BMPs as a first line of defense. Prevent erosion rather than treat turbid runoff.
- Select BMPs depending on site characteristics (topography, drainage, soil type, ground cover, and critical areas) and the construction plan.
- Divert runoff away from exposed areas wherever possible. Keep clean water clean.
- Limit the extent of clearing operations and phase construction operations.
- Before reseeding a disturbed soil area, amend all soils with compost wherever topsoil has been removed.
- Incorporate natural drainage features whenever possible, using adequate buffers and protecting areas where flow enters the drainage system.
- Minimize slope length and steepness.
- Reduce runoff velocities to prevent channel erosion.
- Prevent the tracking of sediment off-site.
- Select appropriate BMPs for the control of pollutants other than sediment.
- Be realistic about the limitations of controls that you specify and the operation and maintenance of those controls. Anticipate what can go wrong, how you can prevent it from happening, and what will need to be done to fix it.

## **3.2 Step-By-Step Procedure**

There are three basic steps in producing a Construction SWPPP:

Step 1 - Data Collection

Step 2 - Data Analysis

Step 3 - Construction SWPPP Development and Implementation

Steps 1 and 2 described below are intended for projects that are adding or replacing 2,000 square feet or more of impervious surface, or clearing 7,000 square feet or more. Single-family home construction projects may

prepare a simpler Construction SWPPP, consisting of a checklist and a plot plan, see Appendix II-C.

### 3.2.1 Step 1 - Data Collection

Evaluate existing site conditions and gather information that will help develop the most effective Construction SWPPP. The information gathered should be explained in the narrative and shown on the drawings.

- **Topography** - Prepare a topographic drawing of the site to show the existing contour elevations at intervals of 1 to 5 feet depending upon the slope of the terrain.
- **Drainage** - Locate and clearly mark existing drainage swales and patterns on the drawing, including existing storm drain pipe systems.
- **Soils** - Identify and label soil type(s) and erodibility (low, medium, high, or an index value from the NRCS manual) on the drawing. Soils information can be obtained from a soil survey if one has been published for the county. If a soil survey is not available, a request can be made to a district Natural Resource Conservation Service Office.

Soils must be characterized for permeability, percent organic matter, and effective depth by a qualified soil professional or engineer. These qualities should be expressed in averaged or nominal terms for the subject site or project. Sometimes this information is available in published literature. Published Soil Conservation Service (SCS) soil surveys information is not available for Tacoma. Soils information should not be used in place of the missing Tacoma information, but can be used to compare to actual site soils investigations.

- **Ground Cover** - Label existing vegetation on the drawing. Such features as tree clusters, grassy areas, and unique or sensitive vegetation should be shown. Unique vegetation may include existing trees above a given diameter. Local requirements regarding tree preservation should be investigated. In addition, existing denuded or exposed soil areas should be indicated.
- **Critical Areas** - Delineate critical areas adjacent to or within the site on the drawing. Such features as steep slopes, streams, floodplains, lakes, wetlands, sole source aquifers, and geologic hazard areas, etc., should be shown. Delineate set backs and buffer limits for these features on the drawings. Other related jurisdictional boundaries such as Shorelines Management and the Federal Emergency Management Agency (FEMA) base floodplain should also be shown on the drawings.



- **Adjacent Areas** - Identify existing buildings, roads, and facilities adjacent to or within the project site on the drawings. Identify existing and proposed utility locations, construction clearing limits, and erosion and sediment control BMPs on the drawings.
- **Existing Encumbrances** - Identify wells, existing and abandoned septic drain fields, utilities, easements, and site constraints.
- **Precipitation Records** - Determine the average monthly rainfall and rainfall intensity for the required design storm events.

### 3.2.2 Step 2 - Data Analysis

Consider the data collected in Step 1 to visualize potential problems and limitations of the site. Determine those areas that have critical erosion hazards. The following are some important factors to consider in data analysis:

- **Topography** - The primary topographic considerations are slope steepness and slope length. Because of the effect of runoff, the longer and steeper the slope, the greater the erosion potential. Erosion potential should be determined by a qualified engineer, soil professional, or certified erosion control specialist.
- **Drainage** - Natural drainage patterns that consist of overland flow, swales and depressions should be used to convey runoff through the site to avoid constructing an artificial drainage system. Man-made ditches and waterways will become part of the erosion problem if they are not properly stabilized. Care should also be taken to ensure that increased runoff from the site will not erode or flood the existing natural drainage system. Possible sites for temporary surface water retention and detention should be considered at this point.

Direct construction away from areas of saturated soil - areas where ground water may be encountered - and critical areas where drainage will concentrate. Preserve natural drainage patterns on the site.

- **Soils** - Evaluate soil properties such as surface and subsurface runoff characteristics, depth to impermeable layer, depth to seasonal ground water table, permeability, shrink-swell potential, texture, settleability, and erodibility. Develop the Construction SWPPP based on known soil characteristics. Infiltration sites should be properly protected from clay and silt which will reduce infiltration capacities.
- **Ground Cover** - Ground cover is the most important factor in terms of preventing erosion. Existing vegetation that can be saved will prevent erosion better than constructed BMPs. Trees and other vegetation protect the soil structure. If the existing vegetation cannot be saved, consider such practices as phasing construction, temporary seeding, and mulching. Phasing of construction involves stabilizing one part of

the site before disturbing another. In this way, the entire site is not disturbed at once.

- **Critical Areas** - Critical areas may include flood hazard areas, mine hazard areas, slide hazard areas, sole source aquifers, wetlands, stream banks, fish-bearing streams, and other water bodies. Any critical areas within or adjacent to the development should exert a strong influence on land development decisions. Critical areas and their buffers shall be delineated on the drawings and clearly flagged in the field. Orange plastic fencing may be more useful than flagging to assure that equipment operators stay out of critical areas. Only unavoidable work should take place within critical areas and their buffers. Such unavoidable work will require special BMPs, permit restrictions, and mitigation plans.
- **Adjacent Areas** - An analysis of adjacent properties should focus on areas upslope and down slope from the construction project. Water bodies that will receive direct runoff from the site are a major concern. The types, values, and sensitivities of and risks to downstream resources, such as private property, surface water facilities, public infrastructure, or aquatic systems, should be evaluated. Erosion and sediment controls should be selected accordingly.
- **Precipitation Records** - Refer to Volume III to determine the required rainfall records and the method of analysis for design of BMPs.
- **Timing of the Project** - An important consideration in selecting BMPs is the timing and duration of the project. Projects that will proceed during the wet season and projects that will last through several seasons must take all necessary precautions to remain in compliance with the water quality standards.

### **3.2.3 Step 3 - Construction SWPPP Development and Implementation**

After collecting and analyzing the data to determine the site limitations, the planner can then develop a Construction SWPPP. Each of the 12 elements below must be considered and included in the Construction SWPPP unless site conditions render the element unnecessary and the exemption from that element is clearly justified in the narrative of the SWPPP.

#### **Element #1: Mark Clearing Limits**

- Prior to beginning land disturbing activities, including clearing and grading, clearly mark all clearing limits, sensitive areas and their buffers, and trees that are to be preserved within the construction area. These shall be clearly marked, both in the field and on the plans, to prevent damage and offsite impacts.
- Plastic, metal, or stake wire fence may be used to mark the clearing limits.

- Suggested BMPs:
  - BMP C101: Preserving Natural Vegetation
  - BMP C102: Buffer Zones
  - BMP C103: High Visibility Plastic or Metal Fence
  - BMP C104: Stake and Wire Fence

**Element #2: Establish Construction Access**

- Construction vehicle access and exit shall be limited to one route if possible, or two for linear projects such as roadways where one access is necessary for large equipment maneuvering.
- Access points shall be stabilized with quarry spall or crushed rock to minimize the tracking of sediment onto public roads.
- Wheel wash or tire baths should be located on site, if applicable.
- No sediment tracking on the roadway is allowed. In the event that sediment is inadvertently tracked onto the road, the road shall be cleaned thoroughly by the end of each day. Sediment shall be removed from roads by shoveling or pickup sweeping and shall be transported to a controlled sediment disposal area. No street washing of sediments to the storm drain system will be allowed. If street wash wastewater can be controlled from entering the storm drainage system, then it shall be pumped back onto the site, contained, and disposed of properly.
- Construction access restoration shall be equal to or better than the pre-construction condition.
- Suggested BMPs:
  - BMP C105: Stabilized Construction Entrance
  - BMP C106: Wheel Wash
  - BMP C107: Construction Road/Parking Area Stabilization

**Element #3: Control Flow Rates**

- Properties and waterways downstream from development sites shall be protected from erosion due to increases in the volume, velocity, and peak flow rate of surface water runoff from the project site.
- Downstream analysis is necessary if changes in offsite flows could impair or alter conveyance systems, stream banks, bed sediment, or aquatic habitat.
- Surface water detention facilities should be constructed as one of the first steps in grading. Detention facilities shall be functional prior to construction of site improvements (e.g. impervious surfaces).
- The City may require pond designs that provide additional or different surface water flow control. This may be necessary to address local conditions or to protect properties and waterways downstream from erosion due to increases in the volume, velocity, and peak flow rate of surface water runoff from the project site.

- If permanent infiltration ponds are used for flow control during construction, these facilities should be protected from siltation during the construction phase.
- Suggested BMPs:
  - Refer to Volume 3, Detention Facilities

#### **Element #4: Install Sediment Controls**

- The duff layer, native topsoil, and natural vegetation shall be retained in an undisturbed state to the maximum extent practicable.
- Prior to leaving a construction site or prior to discharge to an infiltration facility, surface water runoff from disturbed areas shall pass through a sediment pond or other appropriate sediment removal BMP. Runoff from fully stabilized areas may be discharged without a sediment removal BMP, but must meet the flow control performance standard of Element #3, bullet #1. Full stabilization means concrete or asphalt paving; quarry spalls used as ditch lining; or the use of rolled erosion products, a bonded fiber matrix product, or vegetative cover in a manner that will fully prevent soil erosion. The City shall inspect and approve areas fully stabilized by means other than pavement or quarry spalls.
- BMPs intended to trap sediment on site shall be constructed as one of the first steps in grading. These BMPs shall be functional before other land disturbing activities take place.
- Earthen structures such as dams, dikes, and diversions shall be seeded and mulched according to the timing indicated in Element #5.
- BMPs intended to trap sediment on site must be located in a manner to avoid interference with the movement of juvenile salmonids attempting to enter off-channel areas or drainages, often during non-storm events, in response to rain event changes in stream elevation or wetted area.
- Suggested BMPs:
  - BMP C230: Straw Bale Barrier
  - BMP C231: Brush Barrier
  - BMP C232: Gravel Filter Berm
  - BMP C233: Silt Fence
  - BMP C234: Vegetated Strip
  - BMP C235: Straw Wattles
  - BMP C240: Sediment Trap
  - BMP C241: Temporary Sediment Pond
  - BMP C250: Construction Stormwater Chemical Treatment
  - BMP C251: Construction Stormwater Filtration

#### **Element #5: Stabilize Soils**

- Exposed and unworked soils shall be stabilized by application of effective BMPs that protect the soil from the erosive forces of raindrops, flowing water, and wind.

- From October 1 through March 31, no soils shall remain exposed and unworked for more than 2 days. From April 1 to September 30, no soils shall remain exposed and unworked for more than 7 days. This stabilization requirement applies to all soils on site, whether at final grade or not. (See City's Clearing and/or Grading Ordinance TMC Section 2.03.330.)
- Soils shall be stabilized at the end of the shift before a holiday or weekend if needed based on the weather forecast.
- Applicable practices include, but are not limited to, temporary and permanent seeding, sodding, mulching, plastic covering, erosion control fabrics and matting, soil application of polyacrylamide (PAM), the early application of gravel base on areas to be paved, and dust control.
- Selected soil stabilization measures shall be appropriate for the time of year, site conditions, estimated duration of use, and the water quality impacts that stabilization agents may have on downstream waters or ground water.
- Soil stockpiles must be stabilized and protected with sediment trapping measures.
- Linear construction activities such as right-of-way and easement clearing, roadway development, pipelines, and trenching for utilities, shall be conducted to meet the soil stabilization requirement. Contractors shall install the bedding materials, roadbeds, structures, pipelines, or utilities and re-stabilize the disturbed soils so that:
  - from October 1 through March 31 no soils shall remain exposed and unworked for more than 2 days and
  - from April 1 to September 30 no soils shall remain exposed and unworked for more than 7 days.
  - See City's Clearing and/or Grading Ordinance, TMC Section 2.03.330
- Suggested BMPs:
  - BMP C120: Temporary and Permanent Seeding
  - BMP C121: Mulching
  - BMP C122: Nets and Blankets
  - BMP C123: Plastic Covering
  - BMP C124: Sodding
  - BMP C125: Topsoiling
  - BMP C126: Polyacrylamide for Soil Erosion Protection
  - BMP C130: Surface Roughening
  - BMP C131: Gradient Terraces
  - BMP C140: Dust Control
  - BMP C180: Small Project Construction Stormwater Pollution Prevention

### **Element #6: Protect Slopes**

- Design, construct, and phase cut and fill slopes in a manner that will minimize erosion.
- Consider soil type and its potential for erosion.
- Reduce slope runoff velocities by reducing continuous length of slope with terracing and diversions, reduce slope steepness, and roughen slope surface.
- Divert upslope drainage and run-on waters with interceptors at top of slope. Surface water from offsite should be handled separately from surface water generated on the site. Diversion of offsite surface water around the site may be a viable option. Diverted flows shall be redirected to the natural drainage location at or before the property boundary.
- Contain down slope collected flows in pipes, slope drains, or protected channels.
- Provide drainage to remove ground water intersecting the slope surface of exposed soil areas.
- Excavated material shall be placed on the uphill side of trenches, consistent with safety and space considerations.
- Stabilize soils on slopes, as specified in Element #5.
- Suggested BMPs:
  - BMP C120: Temporary and Permanent Seeding
  - BMP C130: Surface Roughening
  - BMP C131: Gradient Terraces
  - BMP C200: Interceptor Dike and Swale
  - BMP C201: Grass-Lined Channels
  - BMP C204: Pipe Slope Drains
  - BMP C205: Subsurface Drains
  - BMP C206: Level Spreader
  - BMP C207: Check Dams
  - BMP C208: Triangular Silt Dike (Geotextile-Encased Check Dam)

### **Element #7: Protect Drain Inlets**

- Storm drain inlets operable during construction shall be protected so that surface water runoff does not enter the conveyance system without first being filtered or treated to remove sediment.
- Approach roads shall be kept clean.
- Inlets should be inspected weekly at a minimum and daily during storm events. Inlet protection devices should be cleaned or removed and replaced before six inches of sediment can accumulate.
- Suggested BMPs:
  - BMP C220: Storm Drain Inlet Protection

### **Element #8: Stabilize Channels and Outlets**

- Temporary on-site conveyance channels shall be designed, constructed, and stabilized to prevent erosion from the expected flow velocity of a 2-year, 24-hour frequency storm for the developed condition. See Volume III, Chapter 4.
- Stabilization, including armoring material, adequate to prevent erosion of outlets, adjacent stream banks, slopes, and downstream reaches shall be provided at the outlets of all conveyance systems.
- Suggested BMPs:
  - BMP C202: Channel Lining
  - BMP C209: Outlet Protection

### **Element #9: Control Pollutants**

- All discharges to the City sewer system (storm or sanitary sewers) require City approval. The approval may include a separate Special Approved Discharge (SAD) permit.
- All pollutants, including waste materials and demolition debris, that occur on site during construction shall be handled and disposed of in a manner that does not cause contamination of surface water. Woody debris may be chopped and spread on site.
- Cover, containment, and protection from vandalism shall be provided for all chemicals, liquid products, petroleum products, and non-inert wastes present on the site (see Chapter 173-304 WAC for the definition of inert waste).
- Maintenance and repair of heavy equipment and vehicles involving oil changes, hydraulic system drain down, solvent and de-greasing cleaning operations, fuel tank drain down and removal, and other activities which may result in discharge or spillage of pollutants to the ground or into surface water runoff must be conducted using spill prevention measures, such as drip pans. Contaminated surfaces shall be cleaned immediately following any discharge or spill incident. Emergency repairs may be performed on-site using temporary plastic placed beneath and, if raining, over the vehicle.
- Wheel wash or tire bath wastewater shall be discharged to a separate on-site treatment system or to the sanitary sewer.
- Application of agricultural chemicals including fertilizers and pesticides shall be conducted in a manner and at application rates that will not result in loss of chemical to surface water runoff. Manufacturers' recommendations for application rates and procedures shall be followed.
- BMPs shall be used to prevent or treat contamination of surface water runoff by pH modifying sources. These sources include bulk cement, cement kiln dust, fly ash, new concrete washing and curing waters, waste streams generated from concrete grinding and sawing, exposed aggregate processes, and concrete pumping and mixer washout waters.

- Suggested BMPs:
  - BMP C151: Concrete Handling
  - BMP C152: Sawcutting and Surfacing Pollution Prevention
  - See Volume IV – Source Control BMPs

**Element #10: Control Dewatering**

- All discharges to the City sewer system (storm or sanitary sewers) require City approval. The approval may include a separate Special Approved Discharge (SAD) permit.
- Foundation, vault, and trench dewatering water shall be discharged into a controlled conveyance system prior to discharge to a sediment pond. Channels must be stabilized, as specified in Element #8.
- Clean, non-turbid dewatering water, such as well-point ground water, can be discharged to systems tributary to state surface waters, as specified in Element #8, provided the dewatering flow does not cause erosion or flooding of receiving waters. These clean waters should not be routed through surface water sediment ponds.
- Highly turbid or contaminated dewatering water from construction equipment operation, clamshell digging, concrete tremie pour, or work inside a cofferdam shall be handled separately from surface water.
- Other disposal options, depending on site constraints, may include:
  1. Infiltration;
  2. Transport off-site in vehicle, such as a vacuum flush truck, for legal disposal in a manner that does not pollute state waters;
  3. On-site treatment using chemical treatment or other suitable treatment technologies;
  4. Sanitary sewer discharge with local sewer utility approval; or
  5. Use of a sedimentation bag with outfall to a ditch or swale for small volumes of localized dewatering.

**Element #11: Maintain BMPs**

- Temporary and permanent erosion and sediment control BMPs shall be maintained and repaired as needed to assure continued performance of their intended function. Maintenance and repair shall be conducted in accordance with BMPs.
- Sediment control BMPs shall be inspected weekly or after a runoff-producing storm event during the dry season and daily during the wet season. The inspection frequency for stabilized, inactive sites shall be determined by the City based on the level of soil stability and potential for adverse environmental impacts.
- Temporary erosion and sediment control BMPs shall be removed within 30 days after final site stabilization is achieved or after the temporary BMPs are no longer needed. Trapped sediment shall be removed or stabilized on site. Disturbed soil resulting from removal of BMPs or vegetation shall be permanently stabilized.



- Maintenance should be included as a separate bid item for each BMP, where applicable.

### **Element #12: Manage the Project**

- **Phasing of Construction** - Development projects shall be phased in order to prevent the transport of sediment from the development site during construction, unless the project engineer can demonstrate that construction phasing is infeasible. Revegetation of exposed areas and maintenance of that vegetation shall be an integral part of the clearing activities for any phase.

Clearing and grading activities for developments shall be permitted only if conducted pursuant to an approved site development plan (e.g., subdivision approval) that establishes permitted areas of clearing, grading, cutting, and filling. When establishing these permitted clearing and grading areas, consideration should be given to minimizing removal of existing trees and minimizing disturbance and compaction of native soils except as needed for building purposes. These permitted clearing and grading areas and any other areas required to preserve critical or sensitive areas, buffers, native growth protection easements, or tree retention areas as may be required by the City, shall be delineated on the site plans and the development site.

- **Seasonal Work Limitations** - From October 1 through March 31, clearing, grading, and other soil disturbing activities shall only be permitted if shown to the satisfaction of the City that the transport of sediment from the construction site to receiving waters will be prevented through a combination of the following:
  1. Site conditions including existing vegetative coverage, slope, soil type, and proximity to receiving waters; and
  2. Limitations on activities and the extent of disturbed areas; and
  3. Proposed erosion and sediment control measures.

Based on the information provided and local weather conditions, the City may expand or restrict the seasonal limitation on site disturbance. The City may take enforcement action - such as a notice of violation, administrative order, penalty, or stop-work order - under the following circumstances:

- If, during the course of any construction activity or soil disturbance during the seasonal limitation period, sediment leaves the construction site causing a violation of the surface water quality standard; or
- If clearing and grading limits or erosion and sediment control measures shown in the approved plan are not maintained.

The following activities are exempt from the seasonal clearing and grading limitations:

1. Routine maintenance and necessary repair of erosion and sediment control BMPs;
  2. Routine maintenance of public facilities or existing utility structures that do not expose the soil or result in the removal of the vegetative cover to soil; and
  3. Activities where there is one hundred percent infiltration of surface water runoff within the site in approved and installed erosion and sediment control facilities.
- **Coordination with Utilities and Other Contractors** - The primary project proponent shall evaluate, with input from utilities and other contractors, the surface water management requirements for the entire project, including the utilities, when preparing the Construction SWPPP.
  - **Inspection and Monitoring** - All BMPs shall be inspected, maintained, and repaired as needed to assure continued performance of their intended function.

A Certified Professional in Erosion and Sediment Control shall be identified in the Construction SWPPP and shall be on-site or on-call at all times. Certification may be through the WSDOT/AGC of Washington Education Foundation Construction Site Erosion and Sediment Control Certification Program or any equivalent local or national certification and/or training program.

Sampling and analysis of the surface water discharges from a construction site may be necessary on a case-by-case basis to ensure compliance with standards. The City may establish monitoring and reporting requirements when necessary, for example, wetlands.

Whenever inspection and/or monitoring reveals that the BMPs identified in the Construction SWPPP are inadequate, due to the actual discharge of or potential to discharge a significant amount of any pollutant, the SWPPP shall be modified, as appropriate, in a timely manner.

- **Reporting** - Report spillage or discharge of pollutants within 24-hours.
- **Maintenance** - Maintenance and repair of heavy equipment and vehicles involving oil changes, hydraulic system drain down, solvent and de-greasing cleaning operations, fuel tank drain down and removal, and other activities which may result in discharge or spillage of pollutants to the ground or into surface water runoff must be conducted using spill prevention measures, such as drip pans. Contaminated surfaces shall be cleaned immediately following any discharge or spill incident. Emergency repairs may be performed on-site using temporary plastic placed beneath and, if raining, over the vehicle.

- **Maintenance of the Construction SWPPP** - The Construction SWPPP shall be retained on-site or within reasonable access to the site. The Construction SWPPP shall be modified whenever there is a significant change in the design, construction, operation, or maintenance of any BMP. The City inspector shall be notified of any changes to the Construction SWPPP. The inspector may require a plan modification to go through the City review process.

### 3.3 Checklists for Construction SWPPPs

The Construction SWPPP consists of two parts: a narrative and the drawings. The following two sections describe the contents of the narrative and the drawings. A checklist is included that can be used as a quick reference to determine if all the major items are included in the Construction SWPPP.

#### 3.3.1 Narrative

The following topic headings shall be used, at a minimum, when preparing the Construction SWPPP narrative.

- **Project Description** – Describe the nature and purpose of the construction project. Include the size of the project area, any increase in existing impervious area, the area disturbed, and the volumes of grading cut and fill that are proposed.
- **Erosion Control Specialist** – A responsible, certified erosion control specialist shall be identified. Telephone and/or pager numbers should be included.
- **Existing Site Conditions** – Describe the existing topography, vegetation, and drainage. Include a description of any structures or development on the parcel including the area of existing impervious surfaces.
- **Adjacent Areas** – Describe adjacent areas, including streams, lakes, wetlands, residential areas, and roads, that might be affected by the construction project. Provide a description of the downstream drainage leading from the site to the receiving body of water.
- **Critical Areas** – Describe areas on or adjacent to the site that are classified as critical areas. Critical areas that receive runoff from the site shall be described up to ¼ mile away. The distance may be increased by the City if special downstream critical areas exist. Describe special requirements for working near or within these areas.
- **Soil** – Describe the soils on the site, giving such information as soil names, mapping unit, erodibility, settleability, permeability, depth, texture, and soil structure.
- **Potential Erosion Problem Areas** – Describe areas on the site that have potential erosion problems.

- Twelve (12) Elements – Describe how the Construction SWPPP addresses each of the 12 required elements. Include the type and location of BMPs used to satisfy the required element. If an element is not applicable to a project, provide a written justification for why it is not necessary.
- Construction Phasing – Describe the construction sequence and any proposed construction phasing.
- Construction Schedule – Describe the construction schedule. If the schedule extends into the wet season, describe what activities will continue during the wet season and how the transport of sediment from the construction site to receiving waters will be prevented.
- Financial/Ownership Responsibilities – Describe ownership and obligations for the project. Include bond forms and other evidence of financial responsibility for performance, maintenance, or mitigation associated with construction.
- Engineering Calculations – Attach any calculations made for the design of such items as sediment ponds, diversions, and waterways, as well as calculations for runoff and surface water detention design (if applicable). Engineering calculations must bear the signature and stamp of an engineer licensed in the state of Washington. References shall be provided for all variables used.

### **3.3.2 Drawings**

- Address; Parcel Number; Section, Township, and Range; scale, bench mark reference, two coordinate reference points matching City coordinate system.
- Vicinity Map – Provide a map locating the site in relation to the surrounding area and roads.
- Number of sheets with index.
- Site Map – Provide a site map(s) showing the following features. The site map requirements may be met using multiple plan sheets for ease of legibility.
  1. A legal description of the property boundaries or an illustration of property lines (including distances) in the drawings.
  2. Show project limits.
  3. The direction of north in relation to the site.
  4. Existing structures and roads, if present.
  5. The boundaries of and label the different soil types.
  6. Areas of potential erosion problems.
  7. Any on-site and adjacent critical areas, their buffers, FEMA base flood boundaries, and Shoreline Management boundaries.

8. Existing contours and drainage basins and the direction of flow for the different drainage areas.
  9. Final grade contours and developed condition drainage basins.
  10. Areas that are to be cleared and graded.
  11. Existing unique or valuable vegetation and the vegetation that is to be preserved.
  12. Cut and fill slopes indicating top and bottom of slope catch lines.
  13. Stockpile, waste storage, and vehicle storage/maintenance areas.
  14. Total cut and fill quantities and the method of disposal for excess material. All existing and proposed utilities and any associated easements.
  15. Proposed structures including roads and parking areas.
- Conveyance Systems – Show on the site map(s) the following temporary and permanent onsite and offsite conveyance features:
    1. Locations for swales, interceptor trenches, or ditches.
    2. Drainage pipes, ditches, or cut-off trenches associated with erosion and sediment control and surface water management.
    3. Temporary and permanent pipe inverts and minimum slopes and cover.
    4. Grades, dimensions, and direction of flow in all ditches and swales, culverts, and pipes.
    5. Details for bypassing offsite runoff around disturbed areas.
    6. Locations and outlets of any dewatering systems.
  - Location of Detention BMPs – Show on the site map the locations of surface water detention BMPs.
  - Erosion and Sediment Control (ESC) Facilities – Show on the site map the following ESC facilities:
    1. The location of sediment pond(s), pipes and structures.
    2. Dimension pond berm widths and inside and outside pond slopes.
    3. The trap/pond storage required and the depth, length, and width dimensions.
    4. Typical section views through pond and outlet structure.
    5. Typical details of gravel cone and standpipe, and/or other filtering devices.
    6. Stabilization technique details for inlets and outlets.
    7. Control/restrictor device location and details.
    8. Mulch and/or recommended cover of berms and slopes.
    9. Rock specifications and detail for rock check dam, if used.
    10. Spacing for rock check dams as required.

11. Front and side sections of typical rock check dams.

12. The location, detail, and specification for silt fence.

13. The construction entrance location and a detail.

- Detailed Drawings – Any structural practices used that are not referenced in this manual should be explained and illustrated with detailed drawings.
- Other Pollutant BMPs – Indicate on the site map the location of BMPs to be used for the control of pollutants other than sediment.
- Monitoring Locations – Indicate on the site map the water quality sampling locations to be used for monitoring water quality on the construction site, if required by the City or the Department of Ecology. Sampling stations shall be located upstream and downstream of the project site discharge point.
- Standard notes are suggested in Appendix A. Notes addressing construction phasing and scheduling shall be included on the drawings.

# Construction Stormwater Pollution Prevention Plan Checklist

Project Name: \_\_\_\_\_  
Address: \_\_\_\_\_  
Parcel No.: \_\_\_\_\_ Section: \_\_\_\_\_ Township: \_\_\_\_\_ Range: \_\_\_\_\_  
City Reference/Permit No.: \_\_\_\_\_  
Review Date: \_\_\_\_\_  
On-Site Inspection Review Date: \_\_\_\_\_  
Construction SWPPP Reviewer: \_\_\_\_\_

## Section I – Construction SWPPP Narrative

### 1. Project Description

- \_\_\_ A. Total Project Area.
- \_\_\_ B. Total proposed impervious area.
- \_\_\_ C. Total proposed area to be disturbed.
- \_\_\_ D. Total volumes of proposed cuts/fill.

### 2. Existing Site Conditions

- \_\_\_ A. Description of the existing topography.
- \_\_\_ B. Description of the existing vegetation.
- \_\_\_ C. Description of the existing drainage.

### 3. Adjacent Areas

- \_\_\_ A. Description of adjacent areas which may be affected by site disturbance
  - \_\_\_ 1. Streams
  - \_\_\_ 2. Lakes
  - \_\_\_ 3. Wetlands
  - \_\_\_ 4. Residential areas
  - \_\_\_ 5. Roads
  - \_\_\_ 6. Ditches, pipes, culverts
  - \_\_\_ 7. Other
- \_\_\_ B. Description of the downstream drainage path leading from the site to the receiving body of water. (Minimum distance of 1/4 mile.)

# Construction Stormwater Pollution Prevention Plan Checklist

Project Name: \_\_\_\_\_  
City Reference/Permit No.: \_\_\_\_\_

## 4. Critical Areas

- \_\_\_ A. Description of critical areas that are on or adjacent to the site.
- \_\_\_ B. Description of special requirements for working in or near critical areas.

## 5. Soils

- \_\_\_ A. Description of on-site soils.
  - \_\_\_ 1. Soil name(s)
  - \_\_\_ 2. Soil mapping unit
  - \_\_\_ 3. Erodibility
  - \_\_\_ 4. Settleability
  - \_\_\_ 5. Permeability
  - \_\_\_ 6. Depth
  - \_\_\_ 7. Texture
  - \_\_\_ 8. Soil structure

## 6. Erosion Problem Areas

- \_\_\_ A. Description of potential erosion problems on site.

## 7. Construction Stormwater Pollution Prevention Elements

- \_\_\_ A. Describe how each of the Construction Stormwater Pollution Prevention Elements has been addressed through the Construction SWPPP.
- \_\_\_ B. Identify the type and location of BMPs used to satisfy the required element.
- \_\_\_ C. Written justification identifying the reason an element is not applicable to the proposal.

12 Required Elements - Construction Stormwater Pollution Prevention Plan:

- \_\_\_ 1. Mark Clearing Limits
- \_\_\_ 2. Establish Construction Access
- \_\_\_ 3. Control Flow Rates
- \_\_\_ 4. Install Sediment Controls
- \_\_\_ 5. Stabilize Soils
- \_\_\_ 6. Protect Slopes
- \_\_\_ 7. Protect Drain Inlets
- \_\_\_ 8. Stabilize Channels and Outlets
- \_\_\_ 9. Control Pollutants
- \_\_\_ 10. Control Dewatering
- \_\_\_ 11. Maintain BMPs
- \_\_\_ 12. Manage the Project



# Construction Stormwater Pollution Prevention Plan Checklist

Project Name: \_\_\_\_\_  
City Reference/Permit No.: \_\_\_\_\_

## 8. Construction Phasing

- A. Construction sequence
- B. Construction phasing (if proposed)

## 9. Construction Schedule

- A. Provide a proposed construction schedule.
- B. Wet Season Construction Activities
  - 1. Proposed wet season construction activities.
  - 2. Proposed wet season construction restraints for environmentally sensitive/critical areas.

## 10. Financial/Ownership Responsibilities

- A. Identify the property owner responsible for the initiation of bonds and/or other financial securities.
- B. Describe bonds and/or other evidence of financial responsibility for liability associated with erosion and sedimentation impacts.
- C. Maintenance bond.

## 11. Engineering Calculations

- A. Provide Design Calculations.
  - 1. Sediment ponds/traps
  - 2. Diversions
  - 3. Waterways
  - 4. Runoff/stormwater detention calculations

# Construction Stormwater Pollution Prevention Plan Checklist

Project Name: \_\_\_\_\_  
Address: \_\_\_\_\_ Parcel No.: \_\_\_\_\_  
City Reference/Permit No.: \_\_\_\_\_

## Section II - Erosion and Sediment Control Plans

### 1. General

- \_\_\_ A. Vicinity Map
- \_\_\_ B. Address, Parcel # and Street names labels
- \_\_\_ C. Erosion and Sediment Control Notes

### 2. Site Plan

- \_\_\_ A. Legal description of subject property.
- \_\_\_ B. North Arrow
- \_\_\_ C. Indicate boundaries of existing vegetation, e.g. tree lines, pasture areas, etc.
- \_\_\_ D. Identify and label areas of potential erosion problems.
- \_\_\_ E. Identify any on-site or adjacent critical areas and associated buffers.
- \_\_\_ F. Identify FEMA base flood boundaries and Shoreline Management boundaries (if applicable).
- \_\_\_ G. Show existing and proposed contours.
- \_\_\_ H. Indicate drainage basins and direction of flow for individual drainage areas.
- \_\_\_ I. Label final grade contours and identify developed condition drainage basins.
- \_\_\_ J. Delineate areas that are to be cleared and graded.
- \_\_\_ K. Show all cut and fill slopes indicating top and bottom of slope catch lines.

### 3. Conveyance Systems

- \_\_\_ A. Designate locations for swales, interceptor trenches, or ditches.
- \_\_\_ B. Show all temporary and permanent drainage pipes, ditches, or cut-off trenches required for erosion and sediment control.
- \_\_\_ C. Provide minimum slope and cover for all temporary pipes or call out pipe inverts.
- \_\_\_ D. Show grades, dimensions, and direction of flow in all ditches, swales, culverts and pipes.
- \_\_\_ E. Provide details for bypassing offsite runoff around disturbed areas.
- \_\_\_ F. Indicate locations and outlets of any dewatering systems.

### 4. Location of Detention BMPs

- \_\_\_ A. Identify location of detention BMPs.

# Construction Stormwater Pollution Prevention Plan Checklist

Project Name: \_\_\_\_\_  
Address: \_\_\_\_\_ Parcel No.: \_\_\_\_\_  
City Reference/Permit No.: \_\_\_\_\_

## 5. Erosion and Sediment Control Facilities

- A. Show the locations of sediment trap(s), pond(s), pipes and structures.
- B. Dimension pond berm widths and inside and outside pond slopes.
- C. Indicate the trap/pond storage required and the depth, length, and width dimensions.
- D. Provide typical section views through pond and outlet structure.
- E. Provide typical details of gravel cone and standpipe, and/or other filtering devices.
- F. Detail stabilization techniques for outlet/inlet.
- G. Detail control/restrictor device location and details.
- H. Specify mulch and/or recommended cover of berms and slopes.
- I. Provide rock specifications and detail for rock check dam(s), if applicable.
- J. Specify spacing for rock check dams as required.
- K. Provide front and side sections of typical rock check dams.
- L. Indicate the locations and provide details and specifications for silt fabric.
- M. Locate the construction entrance and provide a detail.

## 6. Detailed Drawings

- A. Any structural practices used that are not referenced in the City's Manual should be explained and illustrated with detailed drawings.

## 7. Other Pollutant BMPs

- A. Indicate on the site plan the location of BMPs to be used for the control of pollutants other than sediment, e.g. concrete wash water.

## 8. Monitoring Locations

- A. Indicate on the site plan the water quality sampling locations to be used for monitoring water quality on the construction site. Sampling stations shall be located upstream and downstream of the project site.
- B. Describe inspection reporting responsibility, documentation, and filing.

Name	Action	Date
Anne Spangler	First Revisions	3/12/2002

## Chapter 4 - Standards and Specifications for Best Management Practices

---

Best Management Practices (BMPs) are defined as schedules of activities, prohibitions of practices, maintenance procedures, and structural and/or managerial practices, that when used singly or in combination, prevent or reduce the release of pollutants to waters of Washington State. This chapter contains standards and specifications for temporary BMPs to be used as applicable during the construction phase of a project.

Section 4.1 contains the standards and specifications for Source Control BMPs.

Section 4.2 contains the standards and specifications for Runoff Conveyance and Treatment BMPs.

The standards for each individual BMP are divided into four sections:

1. Purpose
2. Conditions of Use
3. Design and Installation Specifications
4. Maintenance Standards

Note that the “Conditions of Use” always refers to site conditions. As site conditions change, BMPs must be changed to remain in compliance.

Information on streambank stabilization is available in the *Integrated Streambank Protection Guidelines*, Washington State Department of Fish and Wildlife, 2000.

## 4.1 Source Control BMPs

### BMP C101: Preserving Natural Vegetation

#### **Purpose**

The purpose of preserving natural vegetation is to reduce erosion wherever practicable. Limiting site disturbance is the single most effective method for reducing erosion. For example, conifers can hold up to about 50 percent of all rain that falls during a storm. Up to 20-30 percent of this rain may never reach the ground but is taken up by the tree or evaporates. Another benefit is that the rain held in the tree can be released slowly to the ground after the storm.

#### **Conditions of Use**

- Natural vegetation should be preserved on steep slopes, near perennial and intermittent watercourses or swales, and on building sites in wooded areas.
- As required by local governments.

#### **Design and Installation Specifications**

Natural vegetation can be preserved in natural clumps or as individual trees, shrubs and vines.

The preservation of individual plants is more difficult because heavy equipment is generally used to remove unwanted vegetation. The points to remember when attempting to save individual plants are:

- Is the plant worth saving? Consider the location, species, size, age, vigor, and the work involved. Local governments may also have ordinances to save natural vegetation and trees.
- Fence or clearly mark areas around trees that are to be saved. It is preferable to keep ground disturbance away from the trees at least as far out as the dripline.

Plants need protection from three kinds of injuries:

- *Construction Equipment* - This injury can be above or below the ground level. Damage results from scarring, cutting of roots, and compaction of the soil. Placing a fenced buffer zone around plants to be saved prior to construction can prevent construction equipment injuries.
- *Grade Changes* - Changing the natural ground level will alter grades, which affects the plant's ability to obtain the necessary air, water, and minerals. Minor fills usually do not cause problems although sensitivity between species does vary and should be checked. Trees can tolerate fill of 6 inches or less. For shrubs and other plants, the fill should be less.

When there are major changes in grade, it may become necessary to supply air to the roots of plants. This can be done by placing a layer of gravel and a tile system over the roots before the fill is made. A tile system protects a tree from a raised grade. The tile system should be laid out on the original grade leading from a dry well around the tree

trunk. The system should then be covered with small stones to allow air to circulate over the root area.

Lowering the natural ground level can seriously damage trees and shrubs. The highest percentage of the plant roots are in the upper 12 inches of the soil and cuts of only 2-3 inches can cause serious injury. To protect the roots it may be necessary to terrace the immediate area around the plants to be saved. If roots are exposed, construction of retaining walls may be needed to keep the soil in place. Plants can also be preserved by leaving them on an undisturbed, gently sloping mound. To increase the chances for survival, it is best to limit grade changes and other soil disturbances to areas outside the dripline of the plant.

- *Excavations* - Protect trees and other plants when excavating for drainfields, power, water, and sewer lines. Where possible, the trenches should be routed around trees and large shrubs. When this is not possible, it is best to tunnel under them. This can be done with hand tools or with power augers. If it is not possible to route the trench around plants to be saved, then the following should be observed:

Cut as few roots as possible. When you have to cut, cut clean. Paint cut root ends with a wood dressing like asphalt base paint.

Backfill the trench as soon as possible.

Tunnel beneath root systems as close to the center of the main trunk to preserve most of the important feeder roots.

Some problems that can be encountered with a few specific trees are:

- Maple, Dogwood, Red alder, Western hemlock, Western red cedar, and Douglas fir do not readily adjust to changes in environment and special care should be taken to protect these trees.
- The windthrow hazard of Pacific silver fir and madronna is high, while that of Western hemlock is moderate. The danger of windthrow increases where dense stands have been thinned. Other species (unless they are on shallow, wet soils less than 20 inches deep) have a low windthrow hazard.
- Cottonwoods, maples, and willows have water-seeking roots. These can cause trouble in sewer lines and infiltration fields. On the other hand, they thrive in high moisture conditions that other trees would not.
- Thinning operations in pure or mixed stands of Grand fir, Pacific silver fir, Noble fir, Sitka spruce, Western red cedar, Western hemlock, Pacific dogwood, and Red alder can cause serious disease problems. Disease can become established through damaged limbs, trunks, roots, and freshly cut stumps. Diseased and weakened trees are also susceptible to insect attack.

***Maintenance Standards***

- Inspect flagged and/or fenced areas regularly to make sure flagging or fencing has not been removed or damaged. If the flagging or fencing has been damaged or visibility reduced, it shall be repaired or replaced immediately and visibility restored.
- If tree roots have been exposed or injured, “prune” cleanly with an appropriate pruning saw or loppers directly above the damaged roots and recover with native soils. Treatment of sap flowing trees (fir, hemlock, pine, soft maples) is not advised as sap forms a natural healing barrier.

## **BMP C102: Buffer Zones**

**Purpose** An undisturbed area or strip of natural vegetation or an established suitable planting that will provide a living filter to reduce soil erosion and runoff velocities.

**Conditions of Use** Natural buffer zones are used along streams, wetlands and other bodies of water that need protection from erosion and sedimentation. Vegetative buffer zones can be used to protect natural swales and can be incorporated into the natural landscaping of an area.

Critical-areas buffer zones should not be used as sediment treatment areas. These areas shall remain completely undisturbed. The local permitting authority may expand the buffer widths temporarily to allow the use of the expanded area for removal of sediment.

### **Design and Installation Specifications**

- Preserving natural vegetation or plantings in clumps, blocks, or strips is generally the easiest and most successful method.
- Leave all unstable steep slopes in natural vegetation.
- Mark clearing limits and keep all equipment and construction debris out of the natural areas. Steel construction fencing is the most effective method in protecting sensitive areas and buffers. Alternatively, wire-backed silt fence on steel posts is marginally effective. Flagging alone is typically not effective.
- Keep all excavations outside the dripline of trees and shrubs.
- Do not push debris or extra soil into the buffer zone area because it will cause damage from burying and smothering.
- Vegetative buffer zones for streams, lakes or other waterways shall be established by the local permitting authority or other state or federal permits or approvals.

### **Maintenance Standards**

- Inspect the area frequently to make sure flagging remains in place and the area remains undisturbed.



## **BMP C103: High Visibility Plastic or Metal Fence**

- Purpose** Fencing is intended to: (1) restrict clearing to approved limits; (2) prevent disturbance of sensitive areas, their buffers, and other areas required to be left undisturbed; (3) limit construction traffic to designated construction entrances or roads; and, (4) protect areas where marking with survey tape may not provide adequate protection.
- Conditions of Use** To establish clearing limits, plastic or metal fence may be used:
- At the boundary of sensitive areas, their buffers, and other areas required to be left uncleared.
  - As necessary to control vehicle access to and on the site.
- Design and Installation Specifications**
- High visibility plastic fence shall be composed of a high-density polyethylene material and shall be at least four feet in height. Posts for the fencing shall be steel or wood and placed every 6 feet on center (maximum) or as needed to ensure rigidity. The fencing shall be fastened to the post every six inches with a polyethylene tie. On long continuous lengths of fencing, a tension wire or rope shall be used as a top stringer to prevent sagging between posts. The fence color shall be high visibility orange. The fence tensile strength shall be 360 lbs./ft. using the ASTM D4595 testing method.
  - Metal fences shall be designed and installed according to the manufacturer's specifications.
  - Metal fences shall be at least 3 feet high and must be highly visible.
  - Fences shall not be wired or stapled to trees.
- Maintenance Standards**
- If the fence has been damaged or visibility reduced, it shall be repaired or replaced immediately and visibility restored.

## **BMP C104: Stake and Wire Fence**

- Purpose** Fencing is intended to: (1) restrict clearing to approved limits; (2) prevent disturbance of sensitive areas, their buffers, and other areas required to be left undisturbed; (3) limit construction traffic to designated construction entrances or roads; and, (4) protect any areas where marking with survey tape may not provide adequate protection.
- Conditions of Use** To establish clearing limits, stake or wire fence may be used:
- At the boundary of sensitive areas, their buffers, and other areas required to be left uncleared.
  - As necessary, to control vehicle access to and on the site.
- Design and Installation Specifications**
- See Figure 4.1 for details.
  - More substantial fencing shall be used if the fence does not prevent encroachment into those areas that are not to be disturbed.
- Maintenance Standards**
- If the fence has been damaged or visibility reduced, it shall be repaired or replaced immediately and visibility restored.

## **BMP C105: Stabilized Construction Entrance**

**Purpose** Construction entrances are stabilized to reduce the amount of sediment transported onto paved roads by vehicles or equipment by constructing a stabilized pad of quarry spalls at entrances to construction sites.

**Conditions of Use** Construction entrances shall be stabilized wherever traffic will be leaving a construction site and traveling on paved roads or other paved areas within 1,000 feet of the site.

On large commercial, highway, and road projects, the designer should include enough extra materials in the contract to allow for additional stabilized entrances not shown in the initial Construction SWPPP. It is difficult to determine exactly where access to these projects will take place; additional materials will enable the contractor to install them where needed.

### **Design and Installation Specifications**

- See Figure 4.2 for details.
- A separation geotextile shall be placed under the spalls to prevent fine sediment from pumping up into the rock pad. The geotextile shall meet the following standards:

Grab Tensile Strength (ASTM D4751)	200 psi min.
Grab Tensile Elongation (ASTM D4632)	30% max.
Mullen Burst Strength (ASTM D3786-80a)	400 psi min.
AOS (ASTM D4751)	20-45 (U.S. standard sieve size)

- Consider early installation of the first lift of asphalt in areas that will be paved; this can be used as a stabilized entrance. Also consider the installation of excess concrete as a stabilized entrance. During large concrete pours, excess concrete is often available for this purpose.
- Hog fuel (wood-based mulch) may be substituted for or combined with quarry spalls in areas that will not be used for permanent roads. Hog fuel is generally less effective at stabilizing construction entrances and should be used only at sites where the amount of traffic is very limited. Hog fuel is not recommended for entrance stabilization in urban areas. The effectiveness of hog fuel is highly variable and it generally requires more maintenance than quarry spalls. The inspector may at any time require the use of quarry spalls if the hog fuel is not preventing sediment from being tracked onto pavement or if the hog fuel is being carried onto pavement. Hog fuel is prohibited in permanent roadbeds because organics in the subgrade soils cause degradation of the subgrade support over time.
- Fencing (see BMPs C103 and C104) shall be installed as necessary to restrict traffic to the construction entrance.
- Whenever possible, the entrance shall be constructed on a firm, compacted subgrade. This can substantially increase the effectiveness of the pad and reduce the need for maintenance.

**Maintenance Standards**

- Quarry spalls (or hog fuel) shall be added if the pad is no longer in accordance with the specifications.
- If the entrance is not preventing sediment from being tracked onto pavement, then alternative measures to keep the streets free of sediment shall be used. This may include street sweeping, an increase in the dimensions of the entrance, or the installation of a wheel wash.
- Any sediment that is tracked onto pavement shall be removed by shoveling or street sweeping. The sediment collected by sweeping shall be removed or stabilized on site. The pavement shall not be cleaned by washing down the street, except when sweeping is ineffective and there is a threat to public safety. If it is necessary to wash the streets, the construction of a small sump shall be considered. The sediment would then be washed into the sump where it can be controlled.
- Any quarry spalls that are loosened from the pad, which end up on the roadway shall be removed immediately.
- If vehicles are entering or exiting the site at points other than the construction entrance(s), fencing (see BMPs C103 and C104) shall be installed to control traffic.
- Upon project completion and site stabilization, all construction accesses intended as permanent access for maintenance shall be permanently stabilized.

## **BMP C106: Wheel Wash**

- Purpose** Wheel washes reduce the amount of sediment transported onto paved roads by motor vehicles.
- Conditions of Use** When a stabilized construction entrance (see BMP C105) is not preventing sediment from being tracked onto pavement.
- Wheel washing is generally an effective BMP when installed with careful attention to topography. For example, a wheel wash can be detrimental if installed at the top of a slope abutting a right-of-way where the water from the dripping truck can run unimpeded into the street.
  - Pressure washing combined with an adequately sized and surfaced pad with direct drainage to a large 10-foot x 10-foot sump can be very effective.

### **Design and Installation Specifications**

Suggested details are shown in Figure 4.3. The Local Permitting Authority may allow other designs. A minimum of 6 inches of asphalt treated base (ATB) over crushed base material or 8 inches over a good subgrade is recommended to pave the wheel wash.

Use a low clearance truck to test the wheel wash before paving. Either a belly dump or lowboy will work well to test clearance.

Keep the water level from 12 to 14 inches deep to avoid damage to truck hubs and filling the truck tongues with water.

Midpoint spray nozzles are only needed in extremely muddy conditions.

Wheel wash systems should be designed with a small grade change, 6 to 12 inches for a 10-foot-wide pond, to allow sediment to flow to the low side of pond to help prevent re-suspension of sediment. A drainpipe with a 2- to 3-foot riser should be installed on the low side of the pond to allow for easy cleaning and refilling. Polymers may be used to promote coagulation and flocculation in a closed-loop system. Polyacrylamide (PAM) added to the wheel wash water at a rate of 0.25 - 0.5 pounds per 1,000 gallons of water increases effectiveness and reduces cleanup time. If PAM is already being used for dust or erosion control and is being applied by a water truck, the same truck can be used to change the wash water.

### **Maintenance Standards**

☐ The wheel wash should start out the day with fresh water.

☐ The wash water should be changed a minimum of once per day. On large earthwork jobs where more than 10-20 trucks per hour are expected, the wash water will need to be changed more often.

☐ Wheel wash or tire bath wastewater shall be discharged to a separate on-site treatment system, such as closed-loop recirculation or land application, or to the sanitary sewer with proper local sewer utility district approval.

## **BMP C107: Construction Road/Parking Area Stabilization**

<b>Purpose</b>	Stabilizing subdivision roads, parking areas, and other onsite vehicle transportation routes immediately after grading reduces erosion caused by construction traffic or runoff.
<b>Conditions of Use</b>	<ul style="list-style-type: none"><li>• Roads or parking areas shall be stabilized wherever they are constructed, whether permanent or temporary, for use by construction traffic.</li><li>• Fencing (see BMPs C103 and C104) shall be installed, if necessary, to limit the access of vehicles to only those roads and parking areas that are stabilized.</li></ul>
<b>Design and Installation Specifications</b>	<ul style="list-style-type: none"><li>• On areas that will receive asphalt as part of the project, install the first lift as soon as possible.</li><li>• A 6-inch depth of 2- to 4-inch crushed rock, gravel base, or crushed surfacing base course shall be applied immediately after grading or utility installation. A 4-inch course of asphalt treated base (ATB) may also be used, or the road/parking area may be paved. It may also be possible to use cement or calcium chloride for soil stabilization. If cement or cement kiln dust is used for roadbase stabilization, pH monitoring and BMPs are necessary to evaluate and minimize the effects on stormwater. If the area will not be used for permanent roads, parking areas, or structures, a 6-inch depth of hog fuel may also be used, but this is likely to require more maintenance. Whenever possible, construction roads and parking areas shall be placed on a firm, compacted subgrade.</li><li>• Temporary road gradients shall not exceed 15 percent. Roadways shall be carefully graded to drain. Drainage ditches shall be provided on each side of the roadway in the case of a crowned section, or on one side in the case of a super-elevated section. Drainage ditches shall be directed to a sediment control BMP.</li><li>• Rather than relying on ditches, it may also be possible to grade the road so that runoff sheet-flows into a heavily vegetated area with a well-developed topsoil. Landscaped areas are not adequate. If this area has at least 50 feet of vegetation, then it is generally preferable to use the vegetation to treat runoff, rather than a sediment pond or trap. The 50 feet shall not include wetlands. If runoff is allowed to sheetflow through adjacent vegetated areas, it is vital to design the roadways and parking areas so that no concentrated runoff is created.</li><li>• Storm drain inlets shall be protected to prevent sediment-laden water entering the storm drain system (see BMP C220).</li></ul>
<b>Maintenance Standards</b>	<ul style="list-style-type: none"><li>• Inspect stabilized areas regularly, especially after large storm events.</li><li>• Crushed rock, gravel base, hog fuel, etc. shall be added as required to maintain a stable driving surface and to stabilize any areas that have eroded.</li><li>• Following construction, these areas shall be restored to pre-construction condition or better to prevent future erosion.</li></ul>

## **BMP C120: Temporary and Permanent Seeding**

<b><i>Purpose</i></b>	Seeding is intended to reduce erosion by stabilizing exposed soils. A well-established vegetative cover is one of the most effective methods of reducing erosion.
<b><i>Conditions of Use</i></b>	<ul style="list-style-type: none"><li>• Seeding may be used throughout the project on disturbed areas that have reached final grade or that will remain unworked for more than 30 days.</li><li>• Channels that will be vegetated should be installed before major earthwork and hydroseeded with a Bonded Fiber Matrix. The vegetation should be well established (i.e., 75 percent cover) before water is allowed to flow in the ditch. With channels that will have high flows, erosion control blankets should be installed over the hydroseed. If vegetation cannot be established from seed before water is allowed in the ditch, sod should be installed in the bottom of the ditch over hydromulch and blankets.</li><li>• Retention/detention ponds should be seeded as required.</li><li>• Mulch is required at all times because it protects seeds from heat, moisture loss, and transport due to runoff.</li><li>• All disturbed areas shall be reviewed in late August to early September and all seeding should be completed by the end of September. Otherwise, vegetation will not establish itself enough to provide more than average protection.</li><li>• At final site stabilization, all disturbed areas not otherwise vegetated or stabilized shall be seeded and mulched. Final stabilization means the completion of all soil disturbing activities at the site and the establishment of a permanent vegetative cover, or equivalent permanent stabilization measures (such as pavement, riprap, gabions or geotextiles) which will prevent erosion.</li></ul>
<b><i>Design and Installation Specifications</i></b>	<ul style="list-style-type: none"><li>• Seeding should be done during those seasons most conducive to growth and will vary with the climate conditions of the region. Local experience should be used to determine the appropriate seeding periods.</li><li>• The optimum seeding windows for western Washington are April 1 through June 30 and September 1 through October 1. Seeding that occurs between July 1 and August 30 will require irrigation until 75 percent grass cover is established. Seeding that occurs between October 1 and March 30 will require a mulch or plastic cover until 75 percent grass cover is established.</li><li>• To prevent seed from being washed away, confirm that all required surface water control measures have been installed.</li></ul>

- The seedbed should be firm and rough. All soil should be roughened no matter what the slope. If compaction is required for engineering purposes, slopes must be track walked before seeding. Backblading or smoothing of slopes greater than 4:1 is not allowed if they are to be seeded.
- New and more effective restoration-based landscape practices rely on deeper incorporation than that provided by a simple single-pass rototilling treatment. Wherever practical the subgrade should be initially ripped to improve long-term permeability, infiltration, and water inflow qualities. At a minimum, permanent areas shall use soil amendments to achieve organic matter and permeability performance defined in engineered soil/landscape systems. For systems that are deeper than 8 inches the rototilling process should be done in multiple lifts, or the prepared soil system shall be prepared properly and then placed to achieve the specified depth.
- Organic matter is the most appropriate form of “fertilizer” because it provides nutrients (including nitrogen, phosphorus, and potassium) in the least water-soluble form. A natural system typically releases 2-10 percent of its nutrients annually. Chemical fertilizers have since been formulated to simulate what organic matter does naturally.
- In general, 10-4-6 N-P-K (nitrogen-phosphorus-potassium) fertilizer can be used at a rate of 90 pounds per acre. Slow-release fertilizers should always be used because they are more efficient and have fewer environmental impacts. It is recommended that areas being seeded for final landscaping conduct soil tests to determine the exact type and quantity of fertilizer needed. This will prevent the over-application of fertilizer. Fertilizer should not be added to the hydromulch machine and agitated more than 20 minutes before it is to be used. If agitated too much, the slow-release coating is destroyed.
- There are numerous products available on the market that take the place of chemical fertilizers. These include several with seaweed extracts that are beneficial to soil microbes and organisms. If 100 percent cottonseed meal is used as the mulch in hydroseed, chemical fertilizer may not be necessary. Cottonseed meal is a good source of long-term, slow-release, available nitrogen.
- Hydroseed applications shall include a minimum of 1,500 pounds per acre of mulch with 3 percent tackifier. Mulch may be made up of 100 percent: cottonseed meal; fibers made of wood, recycled cellulose, hemp, and kenaf; compost; or blends of these. Tackifier shall be plant-based, such as guar or alpha plantago, or chemical-based such as polyacrylamide or polymers. Any mulch or tackifier product used shall be installed per manufacturer’s instructions. Generally, mulches come in 40-50 pound bags. Seed and fertilizer are added at time of application.
- Mulch is always required for seeding. Mulch can be applied on top of the seed or simultaneously by hydroseeding.



- On steep slopes, Bonded Fiber Matrix (BFM) or Mechanically Bonded Fiber Matrix (MBFM) products should be used. BFM/MBFM products are applied at a minimum rate of 3,000 pounds per acre of mulch with approximately 10 percent tackifier. Application is made so that a minimum of 95 percent soil coverage is achieved. Numerous products are available commercially and should be installed per manufacturer's instructions. Most products require 24-36 hours to cure before a rainfall and cannot be installed on wet or saturated soils. Generally, these products come in 40-50 pound bags and include all necessary ingredients except for seed and fertilizer.

BFMs and MBFMs have some advantages over blankets:

- No surface preparation required;
- Can be installed via helicopter in remote areas;
- On slopes steeper than 2.5:1, blanket installers may need to be roped and harnessed for safety;
- They are at least \$1,000 per acre cheaper installed.

In most cases, the shear strength of blankets is not a factor when used on slopes, only when used in channels. BFMs and MBFMs are good alternatives to blankets in most situations where vegetation establishment is the goal.

- When installing seed via hydroseeding operations, only about 1/3 of the seed actually ends up in contact with the soil surface. This reduces the ability to establish a good stand of grass quickly. One way to overcome this is to increase seed quantities by up to 50 percent.
- Vegetation establishment can also be enhanced by dividing the hydromulch operation into two phases:
  1. Phase 1- Install all seed and fertilizer with 25-30 percent mulch and tackifier onto soil in the first lift;
  2. Phase 2- Install the rest of the mulch and tackifier over the first lift.

An alternative is to install the mulch, seed, fertilizer, and tackifier in one lift. Then, spread or blow straw over the top of the hydromulch at a rate of about 800-1000 pounds per acre. Hold straw in place with a standard tackifier. Both of these approaches will increase cost moderately but will greatly improve and enhance vegetative establishment. The increased cost may be offset by the reduced need for:

1. Irrigation
2. Reapplication of mulch
3. Repair of failed slope surfaces

This technique works with standard hydromulch (1,500 pounds per acre minimum) and BFM/MBFMs (3,000 pounds per acre minimum).

- Areas to be permanently landscaped shall provide a healthy topsoil that reduces the need for fertilizers, improves overall topsoil quality, provides for better vegetal health and vitality, improves hydrologic characteristics, and reduces the need for irrigation. This can be accomplished in a number of ways:

Recent research has shown that the best method to improve till soils is to amend these soils with compost. The optimum mixture is approximately two parts soil to one part compost. This equates to 4 inches of compost mixed to a depth of 12 inches in till soils. Increasing the concentration of compost beyond this level can have negative effects on vegetal health, while decreasing the concentrations can reduce the benefits of amended soils. Please note: The compost should meet specifications for Grade A quality compost in Ecology Publication [98-3894-038](#).

Other soils, such as gravel or cobble outwash soils, may require different approaches. Organics and fines easily migrate through the loose structure of these soils. Therefore, the importation of at least 6 inches of quality topsoil, underlain by some type of filter fabric to prevent the migration of fines, may be more appropriate for these soils.

Areas that already have good topsoil, such as undisturbed areas, do not require soil amendments.

- Areas that will be seeded only and not landscaped may need compost or meal-based mulch included in the hydroseed in order to establish vegetation. Native topsoil should be re-installed on the disturbed soil surface before application.
- Seed that is installed as a temporary measure may be installed by hand if it will be covered by straw, mulch, or topsoil. Seed that is installed as a permanent measure may be installed by hand on small areas (usually less than 1 acre) that will be covered with mulch, topsoil, or erosion blankets. The seed mixes listed below include recommended mixes for both temporary and permanent seeding. These mixes, with the exception of the wetland mix, shall be applied at a rate of 120 pounds per acre. This rate can be reduced if soil amendments or slow-release fertilizers are used. Local suppliers or the local conservation district should be consulted for their recommendations because the appropriate mix depends on a variety of factors, including location, exposure, soil type, slope, and expected foot traffic. Alternative seed mixes approved by the local authority may be used.

Table 4.1 represents the standard mix for those areas where just a temporary vegetative cover is required.

Table 4.2 provides just one recommended possibility for landscaping seed.

This turf seed mix in Table 4.3 is for dry situations where there is no need for much water. The advantage is that this mix requires very little maintenance.

Table 4.4 presents a mix recommended for bioswales and other intermittently wet areas.

The seed mix shown in Table 4.5 is a recommended low-growing, relatively non-invasive seed mix appropriate for very wet areas that are not regulated wetlands. Other mixes may be appropriate, depending on the soil type and hydrology of the area. Recent research suggests that bentgrass (*agrostis* sp.) should be emphasized in wet-area seed mixes. Apply this mixture at a rate of 60 pounds per acre.

The meadow seed mix in Table 4.6 is recommended for areas that will be maintained infrequently or not at all and where colonization by native plants is desirable. Likely applications include rural road and utility right-of-way. Seeding should take place in September or very early October in order to obtain adequate establishment prior to the winter months. The appropriateness of clover in the mix may need to be considered, as this can be a fairly invasive species. If the soil is amended, the addition of clover may not be necessary.

**Maintenance Standards**

- Any seeded areas that fail to establish at least 80 percent cover (100 percent cover for areas that receive sheet or concentrated flows) shall be reseeded. If reseeding is ineffective, an alternate method, such as sodding, mulching, or nets/blankets, shall be used. If winter weather prevents adequate grass growth, this time limit may be relaxed at the discretion of the local authority when sensitive areas would otherwise be protected.
- After adequate cover is achieved, any areas that experience erosion shall be reseeded and protected by mulch. If the erosion problem is drainage related, the problem shall be fixed and the eroded area reseeded and protected by mulch.
- Seeded areas shall be supplied with adequate moisture, but not watered to the extent that it causes runoff.

## **BMP C121: Mulching**

**Purpose** The purpose of mulching soils is to provide immediate temporary protection from erosion. Mulch also enhances plant establishment by conserving moisture, holding fertilizer, seed, and topsoil in place, and moderating soil temperatures. There is an enormous variety of mulches that can be used. Only the most common types are discussed in this section.

**Conditions of Use** As a temporary cover measure, mulch should be used:

- On disturbed areas that require cover measures for less than 30 days.
- As a cover for seed during the wet season and during the hot summer months.
- During the wet season on slopes steeper than 3H:1V with more than 10 feet of vertical relief.
- Mulch may be applied at any time of the year and must be refreshed periodically.

**Design and Installation Specifications** For mulch materials, application rates, and specifications, see Table 4.7. Note: Thicknesses may be increased for disturbed areas in or near sensitive areas or other areas highly susceptible to erosion.

Mulch used within the ordinary high-water mark of surface waters should be selected to minimize potential flotation of organic matter. Composted organic materials have higher specific gravities (densities) than straw, wood, or chipped material.

**Maintenance Standards**

- The thickness of the cover must be maintained.
- Any areas that experience erosion shall be remulched and/or protected with a net or blanket. If the erosion problem is drainage related, then the problem shall be fixed and the eroded area remulched.

## **BMP C122: Nets and Blankets**

### ***Purpose***

Erosion control nets and blankets are intended to prevent erosion and hold seed and mulch in place on steep slopes and in channels so that vegetation can become well established. In addition, some nets and blankets can be used to permanently reinforce turf to protect drainage ways during high flows. Nets (commonly called matting) are strands of material woven into an open, but high-tensile strength net (for example, coconut fiber matting). Blankets are strands of material that are not tightly woven, but instead form a layer of interlocking fibers, typically held together by a biodegradable or photodegradable netting (for example, excelsior or straw blankets). They generally have lower tensile strength than nets, but cover the ground more completely. Coir (coconut fiber) fabric comes as both nets and blankets.

### ***Conditions of Use***

Erosion control nets and blankets should be used:

- To aid permanent vegetated stabilization of slopes 2H:1V or greater and with more than 10 feet of vertical relief.
- For drainage ditches and swales (highly recommended). The application of appropriate netting or blanket to drainage ditches and swales can protect bare soil from channelized runoff while vegetation is established. Nets and blankets also can capture a great deal of sediment due to their open, porous structure. Synthetic nets and blankets can be used to permanently stabilize channels and may provide a cost-effective, environmentally preferable alternative to riprap. 100 percent synthetic blankets manufactured for use in ditches may be easily reused as temporary ditch liners.

Disadvantages of blankets include:

- Surface preparation required;
- On slopes steeper than 2.5:1, blanket installers may need to be roped and harnessed for safety;
- They cost at least \$4,000-6,000 per acre installed.

Advantages of blankets include:

- Can be installed without mobilizing special equipment;
- Can be installed by anyone with minimal training;
- Can be installed in stages or phases as the project progresses;
- Seed and fertilizer can be hand-placed by the installers as they progress down the slope;
- Can be installed in any weather;
- There are numerous types of blankets that can be designed with various parameters in mind. Those parameters include: fiber blend, mesh strength, longevity, biodegradability, cost, and availability.

## **Design and Installation Specifications**

- See Figure 4.4 and Figure 4.5 for typical orientation and installation of blankets used in channels and as slope protection. Note: these are typical only; all blankets must be installed per manufacturer's installation instructions.
- Installation is critical to the effectiveness of these products. If good ground contact is not achieved, runoff can concentrate under the product, resulting in significant erosion.
- Installation of Blankets on Slopes:
  1. Complete final grade and track walk up and down the slope.
  2. Install hydromulch with seed and fertilizer.
  3. Dig a small trench, approximately 12 inches wide by 6 inches deep along the top of the slope.
  4. Install the leading edge of the blanket into the small trench and staple approximately every 18 inches. NOTE: Staples are metal, "U"-shaped, and a minimum of 6 inches long. Longer staples are used in sandy soils. Biodegradable stakes are also available.
  5. Roll the blanket slowly down the slope as installer walks backwards. NOTE: The blanket rests against the installer's legs. Staples are installed as the blanket is unrolled. It is critical that the proper staple pattern is used for the blanket being installed. The blanket is not to be allowed to roll down the slope on its own as this stretches the blanket making it impossible to maintain soil contact. In addition, no one is allowed to walk on the blanket after it is in place.
  6. If the blanket is not long enough to cover the entire slope length, the trailing edge of the upper blanket should overlap the leading edge of the lower blanket and be stapled. On steeper slopes, this overlap should be installed in a small trench, stapled, and covered with soil.
- With the variety of products available, it is impossible to cover all the details of appropriate use and installation. Therefore, it is critical that the design engineer consults the manufacturer's information and that a site visit takes place in order to insure that the product specified is appropriate. Information is also available at the following web sites:
  1. WSDOT: <http://www.wsdot.wa.gov/eesc/environmental/>
  2. Texas Transportation Institute: <http://www.dot.state.tx.us/insdtdot/orgchart/cmd/erosion/contents.htm>
- Jute matting must be used in conjunction with mulch (BMP C121). Excelsior, woven straw blankets and coir (coconut fiber) blankets may be installed without mulch. There are many other types of erosion control nets and blankets on the market that may be appropriate in certain circumstances.

***Maintenance  
Standards***

- In general, most nets (e.g., jute matting) require mulch in order to prevent erosion because they have a fairly open structure. Blankets typically do not require mulch because they usually provide complete protection of the surface.
- Extremely steep, unstable, wet, or rocky slopes are often appropriate candidates for use of synthetic blankets, as are riverbanks, beaches and other high-energy environments. If synthetic blankets are used, the soil should be hydromulched first.
- 100 percent biodegradable blankets are available for use in sensitive areas. These organic blankets are usually held together with a paper or fiber mesh and stitching which may last up to a year.
- Most netting used with blankets is photodegradable, meaning they break down under sunlight (not UV stabilized). However, this process can take months or years even under bright sun. Once vegetation is established, sunlight does not reach the mesh. It is not uncommon to find non-degraded netting still in place several years after installation. This can be a problem if maintenance requires the use of mowers or ditch cleaning equipment. In addition, birds and small animals can become trapped in the netting.
- Good contact with the ground must be maintained, and erosion must not occur beneath the net or blanket.
- Any areas of the net or blanket that are damaged or not in close contact with the ground shall be repaired and stapled.
- If erosion occurs due to poorly controlled drainage, the problem shall be fixed and the eroded area protected.

## **BMP C123: Plastic Covering**

**Purpose** Plastic covering provides immediate, short-term erosion protection to slopes and disturbed areas.

- Conditions of Use**
- Plastic covering may be used on disturbed areas that require cover measures for less than 30 days, except as stated below.
  - Plastic is particularly useful for protecting cut and fill slopes and stockpiles. Note: The relatively rapid breakdown of most polyethylene sheeting makes it unsuitable for long-term (greater than six months) applications.
  - Clear plastic sheeting can be used over newly-seeded areas to create a greenhouse effect and encourage grass growth if the hydroseed was installed too late in the season to establish 75 percent grass cover, or if the wet season started earlier than normal. Clear plastic should not be used for this purpose during the summer months because the resulting high temperatures can kill the grass.
  - Due to rapid runoff caused by plastic sheeting, this method shall not be used upslope of areas that might be adversely impacted by concentrated runoff. Such areas include steep and/or unstable slopes.
  - While plastic is inexpensive to purchase, the added cost of installation, maintenance, removal, and disposal make this an expensive material, up to \$1.50-2.00 per square yard.
  - Whenever plastic is used to protect slopes, water collection measures must be installed at the base of the slope. These measures include plastic-covered berms, channels, and pipes used to convey clean rainwater away from bare soil and disturbed areas. At no time is clean runoff from a plastic covered slope to be mixed with dirty runoff from a project.
  - Other uses for plastic include:
    1. Temporary ditch liner;
    2. Pond liner in temporary sediment pond;
    3. Liner for bermed temporary fuel storage area if plastic is not reactive to the type of fuel being stored;
    4. Emergency slope protection during heavy rains; and,
    5. Temporary drainpipe (“elephant trunk”) used to direct water.



**Design and  
Installation  
Specifications**

- Plastic slope cover must be installed as follows:
  1. Run plastic up and down slope, not across slope;
  2. Plastic may be installed perpendicular to a slope if the slope length is less than 10 feet;
  3. Minimum of 8-inch overlap at seams;
  4. On long or wide slopes, or slopes subject to wind, all seams should be taped;
  5. Place plastic into a small (12-inch wide by 6-inch deep) slot trench at the top of the slope and backfill with soil to keep water from flowing underneath;
  6. Place sand filled burlap or geotextile bags every 3 to 6 feet along seams and pound a wooden stake through each to hold them in place;
  7. Inspect plastic for rips, tears, and open seams regularly and repair immediately. This prevents high velocity runoff from contacting bare soil which causes extreme erosion;
  8. Sandbags may be lowered into place tied to ropes. However, all sandbags must be staked in place.

**Maintenance  
Standards**

- Plastic sheeting shall have a minimum thickness of 0.06 millimeters.
- If erosion at the toe of a slope is likely, a gravel berm, riprap, or other suitable protection shall be installed at the toe of the slope in order to reduce the velocity of runoff.
- Torn sheets must be replaced and open seams repaired.
- If the plastic begins to deteriorate due to ultraviolet radiation, it must be completely removed and replaced.
- When the plastic is no longer needed, it shall be completely removed.
- Dispose of old tires appropriately.

## **BMP C124: Sodding**

**Purpose** The purpose of sodding is to establish permanent turf for immediate erosion protection and to stabilize drainage ways where concentrated overland flow will occur.

**Conditions of Use** Sodding may be used in the following areas:

- Disturbed areas that require short-term or long-term cover.
- Disturbed areas that require immediate vegetative cover.
- All waterways that require vegetative lining. Waterways may also be seeded rather than sodded, and protected with a net or blanket.

**Design and Installation Specifications** Sod shall be free of weeds, of uniform thickness (approximately 1-inch thick), and shall have a dense root mat for mechanical strength.

The following steps are recommended for sod installation:

- Shape and smooth the surface to final grade in accordance with the approved grading plan. The swale needs to be overexcavated 4 to 6 inches below design elevation to allow room for placing soil amendment and sod.
- Amend 4 inches (minimum) of compost into the top 8 inches of the soil if the organic content of the soil is less than ten percent or the permeability is less than 0.6 inches per hour. Compost used should meet Ecology publication [98-3894-038](#) specifications for Grade A quality compost.
- Fertilize according to the supplier's recommendations.
- Work lime and fertilizer 1 to 2 inches into the soil, and smooth the surface.
- Lay strips of sod beginning at the lowest area to be sodded and perpendicular to the direction of water flow. Wedge strips securely into place. Square the ends of each strip to provide for a close, tight fit. Stagger joints at least 12 inches. Staple on slopes steeper than 3H:1V. Staple the upstream edge of each sod strip.
- Roll the sodded area and irrigate.
- When sodding is carried out in alternating strips or other patterns, seed the areas between the sod immediately after sodding.

**Maintenance Standards** If the grass is unhealthy, the cause shall be determined and appropriate action taken to reestablish a healthy groundcover. If it is impossible to establish a healthy groundcover due to frequent saturation, instability, or some other cause, the sod shall be removed, the area seeded with an appropriate mix, and protected with a net or blanket.

## **BMP C125: Topsoiling**

### ***Purpose***

To provide a suitable growth medium for final site stabilization with vegetation. While not a permanent cover practice in itself, topsoiling is an integral component of providing permanent cover in those areas where there is an unsuitable soil surface for plant growth. Native soils and disturbed soils that have been organically amended not only retain much more stormwater, but they also serve as effective biofilters for urban pollutants and, by supporting more vigorous plant growth, reduce the water, fertilizer and pesticides needed to support installed landscapes. Topsoil does not include any subsoils but only the material from the top several inches including organic debris.

### ***Conditions of Use***

- Native soils should be left undisturbed to the maximum extent practicable. Native soils disturbed during clearing and grading should be restored, to the maximum extent practicable, to a condition where moisture-holding capacity is equal to or better than the original site conditions. This criterion can be met by using on-site native topsoil, incorporating amendments into on-site soil, or importing blended topsoil.
- Topsoiling is a required procedure when establishing vegetation on shallow soils, and soils of critically low pH (high acid) levels.
- Stripping of existing, properly functioning soil system and vegetation for the purpose of topsoiling during construction is not acceptable. If an existing soil system is functioning properly it shall be preserved in its undisturbed and uncompacted condition.
- Depending on where the topsoil comes from, or what vegetation was on site before disturbance, invasive plant seeds may be included and could cause problems for establishing native plants, landscaped areas, or grasses.
- Topsoil from the site will contain mycorrhizal bacteria that are necessary for healthy root growth and nutrient transfer. These native mycorrhiza are acclimated to the site and will provide optimum conditions for establishing grasses. Commercially available mycorrhiza products should be used when topsoil is brought in from off-site.

### ***Design and Installation Specifications***

If topsoiling is to be done, the following items should be considered:

- Maximize the depth of the topsoil wherever possible to provide the maximum possible infiltration capacity and beneficial growth medium. Topsoil depth shall be at least 8 inches with a minimum organic content of 10 percent dry weight and pH between 6.0 and 8.0 or matching the pH of the undisturbed soil. This can be accomplished either by returning native topsoil to the site and/or incorporating organic amendments. Organic amendments should be incorporated to a minimum 8-inch depth except where tree roots or other natural features limit the depth of incorporation. Subsoils below the 12-inch depth should be scarified at least 2 inches to avoid stratified layers, where feasible. The decision to either layer topsoil over a subgrade

or incorporate topsoil into the underlying layer may vary depending on the planting specified.

- If blended topsoil is imported, then fines should be limited to 25 percent passing through a 200 sieve.
- The final composition and construction of the soil system will result in a natural selection or favoring of certain plant species over time. For example, recent practices have shown that incorporation of topsoil may favor grasses, while layering with mildly acidic, high-carbon amendments may favor more woody vegetation.
- Locate the topsoil stockpile so that it meets specifications and does not interfere with work on the site. It may be possible to locate more than one pile in proximity to areas where topsoil will be used.
- Allow sufficient time in scheduling for topsoil to be spread prior to seeding, sodding, or planting.
- Care must be taken not to apply to subsoil if the two soils have contrasting textures. Sandy topsoil over clayey subsoil is a particularly poor combination, as water creeps along the junction between the soil layers and causes the topsoil to slough.
- If topsoil and subsoil are not properly bonded, water will not infiltrate the soil profile evenly and it will be difficult to establish vegetation. The best method to prevent a lack of bonding is to actually work the topsoil into the layer below for a depth of at least 6 inches.
- Ripping or re-structuring the subgrade may also provide additional benefits regarding the overall infiltration and interflow dynamics of the soil system.
- Field exploration of the site shall be made to determine if there is surface soil of sufficient quantity and quality to justify stripping. Topsoil shall be friable and loamy (loam, sandy loam, silt loam, sandy clay loam, clay loam). Areas of natural ground water recharge should be avoided.
- Stripping shall be confined to the immediate construction area. A 4- to 6- inch stripping depth is common, but depth may vary depending on the particular soil. All surface runoff control structures shall be in place prior to stripping.

Stockpiling of topsoil shall occur in the following manner:

- Side slopes of the stockpile shall not exceed 2:1.
- An interceptor dike with gravel outlet and silt fence shall surround all topsoil stockpiles between October 1 and April 30. Between May 1 and September 30, an interceptor dike with gravel outlet and silt fence shall be installed if the stockpile will remain in place for a longer period of time than active construction grading.

- Erosion control seeding or covering with clear plastic or other mulching materials of stockpiles shall be completed within 2 days (October 1 through April 30) or 7 days (May 1 through September 30) of the formation of the stockpile. Native topsoil stockpiles shall not be covered with plastic.
- Topsoil shall not be placed while in a frozen or muddy condition, when the subgrade is excessively wet, or when conditions exist that may otherwise be detrimental to proper grading or proposed sodding or seeding.
- Previously established grades on the areas to be topsoiled shall be maintained according to the approved plan.
- When native topsoil is to be stockpiled and reused the following should apply to ensure that the mycorrhizal bacterial, earthworms, and other beneficial organisms will not be destroyed:
  1. Topsoil is to be re-installed within 4 to 6 weeks;
  2. Topsoil is not to become saturated with water;
  3. Plastic cover is not allowed.
- Inspect stockpiles regularly, especially after large storm events. Stabilize any areas that have eroded.

***Maintenance  
Standards***

## **BMP C126: Polyacrylamide for Soil Erosion Protection**

**Purpose** Polyacrylamide (PAM) is used on construction sites to prevent soil erosion.

Applying PAM to bare soil in advance of a rain event significantly reduces erosion and controls sediment in two ways. First, PAM increases the soil's available pore volume, thus increasing infiltration through flocculation and reducing the quantity of stormwater runoff. Second, it increases flocculation of suspended particles and aids in their deposition, thus reducing stormwater runoff turbidity and improving water quality.

**Conditions of Use** PAM shall not be directly applied to water or allowed to enter a water body.

In areas that drain to a sediment pond, PAM can be applied to bare soil under the following conditions:

- During rough grading operations.
- Staging areas.
- Balanced cut and fill earthwork.
- Haul roads prior to placement of crushed rock surfacing.
- Compacted soil roadbase.
- Stockpiles.
- After final grade and before paving or final seeding and planting.
- Pit sites.
- Sites having a winter shut down. In the case of winter shut down, or where soil will remain unworked for several months, PAM should be used together with mulch.

### **Design and Installation Specifications**

PAM may be applied in dissolved form with water, or it may be applied in dry, granular or powdered form. The preferred application method is the dissolved form.

PAM is to be applied at a maximum rate of 1/2 pound PAM per 1000 gallons water per 1 acre of bare soil. Table 4.8 and Figure 4.6 can be used to determine the PAM and water application rate for a disturbed soil area. Higher concentrations of PAM **do not** provide any additional effectiveness.

#### The Preferred Method:

- Pre-measure the area where PAM is to be applied and calculate the amount of product and water necessary to provide coverage at the specified application rate (1/2 pound PAM/1000 gallons/acre).
- PAM has infinite solubility in water, but dissolves very slowly. Dissolve pre-measured dry granular PAM with a known quantity of clean water in a bucket several hours or overnight. Mechanical mixing will help dissolve the PAM. Always add PAM to water - not water to PAM.
- Pre-fill the water truck about 1/8 full with water. The water does not have to be potable, but it must have relatively low turbidity – in the range of 20 NTU or less.

- Add PAM /Water mixture to the truck
- Completely fill the water truck to specified volume.
- Spray PAM/Water mixture onto dry soil until the soil surface is uniformly and completely wetted.

An Alternate Method:

PAM may also be applied as a powder at the rate of 5 lbs. per acre. This must be applied on a day that is dry. For areas less than 5-10 acres, a hand-held “organ grinder” fertilizer spreader set to the smallest setting will work. Tractor-mounted spreaders will work for larger areas.

The following shall be used for application of PAM:

- PAM shall be used in conjunction with other BMPs and not in place of other BMPs.
- Do not use PAM on a slope that flows directly into a stream or wetland. The stormwater runoff shall pass through a sediment control BMP prior to discharging to surface waters.
- Do not add PAM to water discharging from site.
- When the total drainage area is greater than or equal to 5 acres, PAM treated areas shall drain to a sediment pond.
- Areas less than 5 acres shall drain to sediment control BMPs, such as a minimum of 3 check dams per acre. The total number of check dams used shall be maximized to achieve the greatest amount of settlement of sediment prior to discharging from the site. Each check dam shall be spaced evenly in the drainage channel through which stormwater flows are discharged off-site.
- On all sites, the use of silt fence shall be maximized to limit the discharges of sediment from the site.
- All areas not being actively worked shall be covered and protected from rainfall. PAM shall not be the only cover BMP used.
- PAM can be applied to wet soil, but dry soil is preferred due to less sediment loss.
- PAM will work when applied to saturated soil but is not as effective as applications to dry or damp soil.
- Keep the granular PAM supply out of the sun. Granular PAM loses its effectiveness in three months after exposure to sunlight and air.
- Proper application and re-application plans are necessary to ensure total effectiveness of PAM usage.
- PAM, combined with water, is very slippery and can be a safety hazard. Care must be taken to prevent spills of PAM powder onto paved surfaces. During an application of PAM, prevent over-spray from reaching pavement as pavement will become slippery. If PAM powder gets on skin or clothing, wipe it off with a rough towel rather than washing with water-this only makes cleanup messier and take longer.

- Some PAMs are more toxic and carcinogenic than others. Only the most environmentally safe PAM products should be used.

The specific PAM copolymer formulation must be anionic. **Cationic PAM shall not be used in any application because of known aquatic toxicity problems.** Only the highest drinking water grade PAM, certified for compliance with ANSI/NSF Standard 60 for drinking water treatment, will be used for soil applications. Recent media attention and high interest in PAM has resulted in some entrepreneurial exploitation of the term "polymer." All PAM are polymers, but not all polymers are PAM, and not all PAM products comply with ANSI/NSF Standard 60. PAM use shall be reviewed and approved by the local permitting authority. The Washington State Department of Transportation (WSDOT) has listed approved PAM products on their web page.

- PAM designated for these uses should be "water soluble" or "linear" or "non-crosslinked". Cross-linked or water absorbent PAM, polymerized in highly acidic (pH<2) conditions, are used to maintain soil moisture content.
- The PAM anionic charge density may vary from 2-30 percent; a value of 18 percent is typical. Studies conducted by the United States Department of Agriculture (USDA)/ARS demonstrated that soil stabilization was optimized by using very high molecular weight (12-15 mg/mole), highly anionic (>20% hydrolysis) PAM.
- PAM tackifiers are available and being used in place of guar and alpha plantago. Typically, PAM tackifiers should be used at a rate of no more than 0.5-1 lb. per 1000 gallons of water in a hydromulch machine. Some tackifier product instructions say to use at a rate of 3 –5 lbs. per acre, which can be too much. In addition, pump problems can occur at higher rates due to increased viscosity.

### **Maintenance Standards**

- PAM may be reapplied on actively worked areas after a 48-hour period.
- Reapplication is not required unless PAM treated soil is disturbed or unless turbidity levels show the need for an additional application. If PAM treated soil is left undisturbed a reapplication may be necessary after two months. More PAM applications may be required for steep slopes, silty and clayey soils (USDA Classification Type "C" and "D" soils), long grades, and high precipitation areas. When PAM is applied first to bare soil and then covered with straw, a reapplication may not be necessary for several months.
- Loss of sediment and PAM may be a basis for penalties per RCW 90.48.080.



## **BMP C130: Surface Roughening**

<b>Purpose</b>	Surface roughening aids in the establishment of vegetative cover, reduces runoff velocity, increases infiltration, and provides for sediment trapping through the provision of a rough soil surface. Horizontal depressions are created by operating a tiller or other suitable equipment on the contour or by leaving slopes in a roughened condition by not fine grading them.
<b>Conditions for Use</b>	<ul style="list-style-type: none"><li>• All slopes steeper than 3:1 and greater than 5 vertical feet require surface roughening.</li><li>• Areas with grades steeper than 3:1 should be roughened to a depth of 2 to 4 inches prior to seeding.</li><li>• Areas that will not be stabilized immediately may be roughened to reduce runoff velocity until seeding takes place.</li><li>• Slopes with a stable rock face do not require roughening.</li><li>• Slopes where mowing is planned should not be excessively roughened.</li></ul>
<b>Design and Installation Specifications</b>	<p>There are different methods for achieving a roughened soil surface on a slope, and the selection of an appropriate method depends upon the type of slope. Roughening methods include stair-step grading, grooving, contour furrows, and tracking. See Figure 4.7 for tracking and contour furrows. Factors to be considered in choosing a method are slope steepness, mowing requirements, and whether the slope is formed by cutting or filling.</p> <ul style="list-style-type: none"><li>• Disturbed areas that will not require mowing may be stair-step graded, grooved, or left rough after filling.</li><li>• Stair-step grading is particularly appropriate in soils containing large amounts of soft rock. Each "step" catches material that sloughs from above, and provides a level site where vegetation can become established. Stairs should be wide enough to work with standard earth moving equipment. Stair steps must be on contour or gullies will form on the slope.</li><li>• Areas that will be mowed (these areas should have slopes less steep than 3:1) may have small furrows left by disking, harrowing, raking, or seed-planting machinery operated on the contour.</li><li>• Graded areas with slopes greater than 3:1 but less than 2:1 should be roughened before seeding. This can be accomplished in a variety of ways, including "track walking," or driving a crawler tractor up and down the slope, leaving a pattern of cleat imprints parallel to slope contours.</li><li>• Tracking is done by operating equipment up and down the slope to leave horizontal depressions in the soil.</li></ul>
<b>Maintenance Standards</b>	<ul style="list-style-type: none"><li>• Areas that are graded in this manner should be seeded as quickly as possible.</li><li>• Regular inspections should be made of the area. If rills appear, they should be re-graded and re-seeded immediately.</li></ul>

## BMP C131: Gradient Terraces

**Purpose** Gradient terraces reduce erosion damage by intercepting surface runoff and conducting it to a stable outlet at a non-erosive velocity.

**Conditions of Use**

- Gradient terraces normally are limited to denuded land having a water erosion problem. They should not be constructed on deep sands or on soils that are too stony, steep, or shallow to permit practical and economical installation and maintenance. Gradient terraces may be used only where suitable outlets are or will be made available. See Figure 4.8 for gradient terraces.

**Design and Installation Specifications**

- The maximum spacing of gradient terraces should be determined by the following method:

$$VI = (0.8)s + y$$

Where: VI = vertical interval in feet

s = land rise per 100 feet, expressed in feet

y = a soil and cover variable with values from 1.0 to 4.0

Values of “y” are influenced by soil erodibility and cover practices. The lower values are applicable to erosive soils where little to no residue is left on the surface. The higher value is applicable only to erosion-resistant soils where a large amount of residue (1½ tons of straw/acre equivalent) is on the surface.

- The minimum constructed cross-section should meet the design dimensions.
- The top of the constructed ridge should not be lower at any point than the design elevation plus the specified overfill for settlement. The opening at the outlet end of the terrace should have a cross section equal to that specified for the terrace channel.
- Channel grades may be either uniform or variable with a maximum grade of 0.6 feet per 100 feet length. For short distances, terrace grades may be increased to improve alignment. The channel velocity should not exceed that which is nonerosive for the soil type with the planned treatment.
- All gradient terraces should have adequate outlets. Such an outlet may be a grassed waterway, vegetated area, or tile outlet. In all cases the outlet must convey runoff from the terrace or terrace system to a point where the outflow will not cause damage. Vegetative cover should be used in the outlet channel.
- The design elevation of the water surface of the terrace should not be lower than the design elevation of the water surface in the outlet at their junction, when both are operating at design flow.
- Vertical spacing determined by the above methods may be increased as much as 0.5 feet or 10 percent, whichever is greater, to provide better alignment or location, to avoid obstacles, to adjust for equipment size, or to reach a satisfactory outlet.

- The drainage area above the top should not exceed the area that would be drained by a terrace with normal spacing.
- The terrace should have enough capacity to handle the peak runoff expected from a 2-year, 24-hour design storm without overtopping.
- The terrace cross-section should be proportioned to fit the land slope. The ridge height should include a reasonable settlement factor. The ridge should have a minimum top width of 3 feet at the design height. The minimum cross-sectional area of the terrace channel should be 8 square feet for land slopes of 5 percent or less, 7 square feet for slopes from 5 to 8 percent, and 6 square feet for slopes steeper than 8 percent. The terrace can be constructed wide enough to be maintained using a small cat.
- Maintenance should be performed as needed. Terraces should be inspected regularly; at least once a year, and after large storm events.

***Maintenance  
Standards***

## **BMP C140: Dust Control**

<b>Purpose</b>	Dust control prevents wind transport of dust from disturbed soil surfaces onto roadways, drainage ways, and surface waters.
<b>Conditions of Use</b>	<ul style="list-style-type: none"><li>• In areas (including roadways) subject to surface and air movement of dust where on-site and off-site impacts to roadways, drainage ways, or surface waters are likely.</li></ul>
<b>Design and Installation Specifications</b>	<ul style="list-style-type: none"><li>• Vegetate or mulch areas that will not receive vehicle traffic. In areas where planting, mulching, or paving is impractical, apply gravel or landscaping rock.</li><li>• Limit dust generation by clearing only those areas where immediate activity will take place, leaving the remaining area(s) in the original condition, if stable. Maintain the original ground cover as long as practical.</li><li>• Construct natural or artificial windbreaks or windscreens. These may be designed as enclosures for small dust sources.</li><li>• Sprinkle the site with water until surface is wet. Repeat as needed. To prevent carryout of mud onto street, refer to Stabilized Construction Entrance (BMP C105).</li><li>• Irrigation water can be used for dust control. Irrigation systems should be installed as a first step on sites where dust control is a concern.</li><li>• Spray exposed soil areas with a dust palliative, following the manufacturer's instructions and cautions regarding handling and application. Used oil is prohibited from use as a dust suppressant. Local governments may approve other dust palliatives such as calcium chloride or PAM.</li><li>• PAM (BMP C126) added to water at a rate of 0.5 lbs. per 1,000 gallons of water per acre and applied from a water truck is more effective than water alone. This is due to the increased infiltration of water into the soil and reduced evaporation. In addition, small soil particles are bonded together and are not as easily transported by wind. Adding PAM may actually reduce the quantity of water needed for dust control, especially in eastern Washington. Since the wholesale cost of PAM is about \$ 4.00 per pound, this is an extremely cost-effective dust control method.</li></ul> <p>Techniques that can be used for unpaved roads and lots include:</p> <ul style="list-style-type: none"><li>• Lower speed limits. High vehicle speed increases the amount of dust stirred up from unpaved roads and lots.</li><li>• Upgrade the road surface strength by improving particle size, shape, and mineral types that make up the surface and base materials.</li><li>• Add surface gravel to reduce the source of dust emission. Limit the amount of fine particles (those smaller than .075 mm) to 10 to 20 percent.</li></ul>

- Use geotextile fabrics to increase the strength of new roads or roads undergoing reconstruction.
- Encourage the use of alternate, paved routes, if available.
- Restrict use by tracked vehicles and heavy trucks to prevent damage to road surface and base.
- Apply chemical dust suppressants using the admix method, blending the product with the top few inches of surface material. Suppressants may also be applied as surface treatments.
- Pave unpaved permanent roads and other trafficked areas.
- Use vacuum street sweepers.
- Remove mud and other dirt promptly so it does not dry and then turn into dust.
- Limit dust-causing work on windy days.
- Contact your local Air Pollution Control Authority for guidance and training on other dust control measures. Compliance with the local Air Pollution Control Authority constitutes compliance with this BMP.

***Maintenance  
Standards***

Respray area as necessary to keep dust to a minimum.

## **BMP C150: Materials On Hand**

### ***Purpose***

Quantities of erosion prevention and sediment control materials can be kept on the project site at all times to be used for emergency situations such as unexpected heavy summer rains. Having these materials on-site reduces the time needed to implement BMPs when inspections indicate that existing BMPs are not meeting the Construction SWPPP requirements. In addition, contractors can save money by buying some materials in bulk and storing them at their office or yard.

### ***Conditions of Use***

- Construction projects of any size or type can benefit from having materials on hand. A small commercial development project could have a roll of plastic and some gravel available for immediate protection of bare soil and temporary berm construction. A large earthwork project, such as highway construction, might have several tons of straw, several rolls of plastic, flexible pipe, sandbags, geotextile fabric and steel “T” posts.
- Materials are stockpiled and readily available before any site clearing, grubbing, or earthwork begins. A large contractor or developer could keep a stockpile of materials that are available to be used on several projects.
- If storage space at the project site is at a premium, the contractor could maintain the materials at their office or yard. The office or yard must be less than an hour from the project site.

### ***Design and Installation Specifications***

Depending on project type, size, complexity, and length, materials and quantities will vary. A good minimum that will cover numerous situations includes:

<b>Material</b>	<b>Measure</b>	<b>Quantity</b>
Clear Plastic, 6 mil	100 foot roll	1-2
Drainpipe, 6 or 8 inch diameter	25 foot section	4-6
Sandbags, filled	each	25-50
Straw Bales for mulching,	approx. 50# each	10-20
Quarry Spalls	ton	2-4
Washed Gravel	cubic yard	2-4
Geotextile Fabric	100 foot roll	1-2
Catch Basin Inserts	each	2-4
Steel “T” Posts	each	12-24

### ***Maintenance Standards***

- All materials with the exception of the quarry spalls, steel “T” posts, and gravel should be kept covered and out of both sun and rain.
- Re-stock materials used as needed.

## **BMP C151: Concrete Handling**

**Purpose** Concrete work can generate process water and slurry that contain fine particles and high pH, both of which can violate water quality standards in the receiving water. This BMP is intended to minimize and eliminate concrete process water and slurry from entering waters of the state.

**Conditions of Use** Any time concrete is used, these management practices shall be utilized. Concrete construction projects include, but are not limited to, the following:

- Curbs
- Sidewalks
- Roads
- Bridges
- Foundations
- Floors
- Runways

**Design and Installation Specifications**

- Concrete truck chutes, pumps, and internals shall be washed out only into formed areas awaiting installation of concrete or asphalt.
- Unused concrete remaining in the truck and pump shall be returned to the originating batch plant for recycling.
- Hand tools including, but not limited to, screeds, shovels, rakes, floats, and trowels shall be washed off only into formed areas awaiting installation of concrete or asphalt.
- Equipment that cannot be easily moved, such as concrete pavers, shall only be washed in areas that do not directly drain to natural or constructed stormwater conveyances.
- Washdown from areas such as concrete aggregate driveways shall not drain directly to natural or constructed stormwater conveyances.
- When no formed areas are available, washwater and leftover product shall be contained in a lined container. Contained concrete shall be disposed of in a manner that does not violate groundwater or surface water quality standards.

**Maintenance Standards** Containers shall be checked for holes in the liner daily during concrete pours and repaired the same day.

## **BMP C152: Sawcutting and Surfacing Pollution Prevention**

<b><i>Purpose</i></b>	Sawcutting and surfacing operations generate slurry and process water that contain fine particles and high pH (concrete cutting), both of which can violate the water quality standards in the receiving water. This BMP is intended to minimize and eliminate process water and slurry from entering waters of the State.
<b><i>Conditions of Use</i></b>	Anytime sawcutting or surfacing operations take place, these management practices shall be utilized. Sawcutting and surfacing operations include, but are not limited to, the following: <ul style="list-style-type: none"><li>• Sawing</li><li>• Coring</li><li>• Grinding</li><li>• Roughening</li><li>• Hydro-demolition</li><li>• Bridge and road surfacing</li></ul>
<b><i>Design and Installation Specifications</i></b>	<ul style="list-style-type: none"><li>• Slurry and cuttings shall be vacuumed during cutting and surfacing operations.</li><li>• Slurry and cuttings shall not remain on permanent concrete or asphalt pavement overnight.</li><li>• Slurry and cuttings shall not drain to any natural or constructed drainage conveyance.</li><li>• Collected slurry and cuttings shall be disposed of in a manner that does not violate groundwater or surface water quality standards.</li><li>• Process water that is generated during hydro-demolition, surface roughening or similar operations shall not drain to any natural or constructed drainage conveyance and shall be disposed of in a manner that does not violate groundwater or surface water quality standards.</li><li>• Cleaning waste material and demolition debris shall be handled and disposed of in a manner that does not cause contamination of water. If the area is swept with a pick-up sweeper, the material must be hauled out of the area to an appropriate disposal site.</li></ul>
<b><i>Maintenance Standards</i></b>	Continually monitor operations to determine whether slurry, cuttings, or process water could enter waters of the state. If inspections show that a violation of water quality standards could occur, stop operations and immediately implement preventive measures such as berms, barriers, secondary containment, and vacuum trucks.



## **BMP C160: Contractor Erosion and Spill Control Lead**

### ***Purpose***

The Contractor designates at least one employee as the responsible representative in charge of erosion and spill control. The designated employee shall be the Contractor Erosion and Spill Control Lead (CESCL) who is responsible for ensuring compliance with all local, state, and federal erosion and sediment control requirements.

### ***Conditions of Use***

A CESCL should be made available on project types that include, but are not limited to, the following:

- Single project of 5 acres or more.
- Projects less than 5 acres that are part of a larger project, or master plan.
- Heavy construction of roads, bridges, highways, airports, buildings.
- Projects near wetlands and sensitive or critical areas.
- Projects in or over water.
- The CESCL shall have a current certificate proving attendance in the "Construction Site Erosion and Sediment Control Certification Course," offered throughout the year by the Associated General Contractors of Washington Educational Foundation or an approved equivalent. Equivalent certificates include:

WSDOT certification in Construction Site Erosion and Sediment Control.

Certified Professional in Erosion and Sediment Control (CPESC) offered by the International Erosion Control Association (IECA).

Other courses approved by Ecology or the Local Permitting Authority.

- Certification shall remain valid for three years.
- The CESCL shall have authority to act on behalf of the contractor or developer and shall be available, on call, 24 hours per day throughout the period of construction.
- The Construction SWPPP shall include the name, telephone number, fax number, and address of the designated CESCL.

Duties and responsibilities of the CESCL shall include, but are not limited to the following:

- Maintaining permit file on site at all times which includes the SWPPP and any associated permits and plans.
- Directing BMP installation, inspection, maintenance, modification, and removal.
- Availability 24 hours per day, 7 days per week by telephone.

- Updating all project drawings and the Construction SWPPP with changes made.
- Keeping daily logs, and inspection reports. Inspection reports should include:
  - When, where and how BMPs were installed, removed, or modified.
  - Repairs needed or made.
  - Observations of BMP effectiveness and proper placement.
  - Recommendations for improving performance of BMPs.
  - Identify the points where storm water runoff potentially leaves the site, is collected in a surface water conveyance system (i.e., road ditch, storm sewer), and enters receiving waters of the state.
  - If water sheet flows from the site, identify the point at which it becomes concentrated in a collection system.
  - Inspect for SWPPP requirements including BMPs as required to ensure adequacy.
- Facilitate, participate in, and take corrective actions resulting from inspections performed by outside agencies or the owner.

## **BMP C161: Payment of Erosion Control Work**

### **Purpose**

As with any construction operation, the contractor should be paid for erosion control work. Payment for erosion control must be addressed during project development and design. Method of payment should be identified in the SWPPP.

### **Conditions of Use**

Erosion control work should never be “incidental” to the contract as it is extremely difficult for the contractor to bid the work. Work that is incidental to the contract is work where no separate measurement or payment is made. The cost for incidental work is included in payments made for applicable bid items in the Schedule of Unit Prices. For example, any erosion control work associated with an item called “Clearing and Grubbing” is bid and paid for as part of that item, not separately.

Several effective means for payment of erosion control work are described below. These include:

- Temporary Erosion and Sediment Control (TESC) Lump Sum.
- TESC-Force Account.
- Unit Prices.
- Lump Sum.

### **TESC Lump Sum**

One good method for achieving effective erosion and sediment control is to set up a Progress Payment system whereby the contract spells out exactly what is expected and allows for monthly payments over the life of the contract.

For example, an Item called “TESC Lump Sum” is listed in the Bid Schedule of Unit Prices. An amount, such as \$10,000, is written in both the Unit Price and Amount columns. This requires all bidders to bid \$10,000 for the item. If \$10,000 is not shown in the Amount column, each contractor bids the amount. Often this is under-bid, which can cause compliance difficulties later. In this example, the contractor is required to revise the project Construction SWPPP by developing a Contractor’s Erosion and Sediment Control Plan (CESCP) that is specific to their operations.

Next, the following language is included in the TESC specification Payment section:

Based upon lump sum Bid Item “TESC Lump Sum”, payments will be made as follows:

- A. Upon receipt of the Contractor’s CESCP, 25 percent.
- B. After Notice To Proceed and before Substantial Completion, 50 percent will be pro rated and paid monthly for compliance with the CESCP. Non-compliance will result in withholding of payment for the month of non-compliance.

C. At Final Payment, 25 percent for a clean site.

Payment for "TESC Lump Sum" will be full compensation for furnishing all labor, equipment, materials and tools to implement the CЕСP, install, inspect, maintain, and remove temporary erosion and sediment controls as detailed in the drawings and specified herein, with the exception of those items measured and paid for separately.

### **TESC Force Account**

One good method for ensuring that contingency money is available to address unforeseen erosion and sediment control problems is to set up an item called "TESC-Force Account". For example, an amount such as \$15,000 is written in both the Unit Price and Amount columns for the item. This requires all bidders to bid \$15,000 for the item.

The Force Account is used only at the discretion of the contracting agency or developer. If there are no unforeseen erosion problems, the money is not used. If there are unforeseen erosion problems, the contracting agency would direct the work to be done and pay an agreed upon amount for the work (such as predetermined rates under a Time and Materials setting).

Contract language for this item could look like this:

Measurement and Payment for "TESC-Force Account" will be on a Force Account basis in accordance with \_\_\_\_\_ (include appropriate section of the Contract Specifications). The amount entered in the Schedule of Unit Prices is an estimate.

### **Unit Prices**

When the material or work can be quantified, it can be paid by Unit Prices. For example, the project designer knows that 2 acres will need to be hydroseeded and sets up an Item of Work for Hydroseed, with a Bid Quantity of 2, and a Unit for Acre. The bidder writes in the unit Prices and Amount.

Unit Price items can be used in conjunction with TЕСS-Force Account and TЕСS-Lump Sum.

### **Lump Sum**

In contracts where all the work in a project is paid as a Lump Sum, erosion control is usually not paid as a separate item. In order to ensure that appropriate amounts are bid into the contract, the contracting agency can request a Schedule of Values and require that all erosion control costs be identified.

## **BMP C162: Scheduling**

- Purpose** Sequencing a construction project reduces the amount and duration of soil exposed to erosion by wind, rain, runoff, and vehicle tracking.
- Conditions of Use** The construction sequence schedule is an orderly listing of all major land-disturbing activities together with the necessary erosion and sedimentation control measures planned for the project. This type of schedule guides the contractor on work to be done before other work is started so that serious erosion and sedimentation problems can be avoided.
- Following a specified work schedule that coordinates the timing of land-disturbing activities and the installation of control measures is perhaps the most cost-effective way of controlling erosion during construction. The removal of surface ground cover leaves a site vulnerable to accelerated erosion. Construction procedures that limit land clearing, provide timely installation of erosion and sedimentation controls, and restore protective cover quickly can significantly reduce the erosion potential of a site.
- Design Considerations**
- Avoid rainy periods.
  - Schedule projects to disturb only small portions of the site at any one time. Complete grading as soon as possible. Immediately stabilize the disturbed portion before grading the next portion. Practice staged seeding in order to revegetate cut and fill slopes as the work progresses.

## **BMP C180: Small Project Construction Stormwater Pollution Prevention**

<b>Purpose</b>	To prevent the discharge of sediment and other pollutants to the maximum extent practicable from small construction projects.
<b>Conditions of Use</b>	On small construction projects, those adding or replacing less than 2,000 square feet of impervious surface or clearing less than 7,000 square feet.
<b>Design and Installation Specifications</b>	<ul style="list-style-type: none"><li>• Plan and implement proper clearing and grading of the site. It is most important only to clear the areas needed, thus keeping exposed areas to a minimum. Phase clearing so that only those areas that are actively being worked are uncovered.</li></ul> <p><i>Note: Clearing limits should be flagged in the lot or area prior to initiating clearing.</i></p> <ul style="list-style-type: none"><li>• Soil shall be managed in a manner that does not permanently compact or deteriorate the final soil and landscape system. If disturbance and/or compaction occur the impact must be corrected at the end of the construction activity. This shall include restoration of soil depth, soil quality, permeability, and percent organic matter. Construction practices must not cause damage to or compromise the design of permanent landscape or infiltration areas.</li><li>• Locate excavated basement soil a reasonable distance behind the curb, such as in the backyard or side yard area. This will increase the distance eroded soil must travel to reach the storm sewer system. Soil piles should be covered until the soil is either used or removed. Piles should be situated so that sediment does not run into the street or adjoining yards.</li><li>• Backfill basement walls as soon as possible and rough grade the lot. This will eliminate large soil mounds, which are highly erodible, and prepares the lot for temporary cover, which will further reduce erosion potential.</li><li>• Remove excess soil from the site as soon as possible after backfilling. This will eliminate any sediment loss from surplus fill.</li><li>• If a lot has a soil bank higher than the curb, a trench or berm should be installed moving the bank several feet behind the curb. This will reduce the occurrence of gully and rill erosion while providing a storage and settling area for stormwater.</li><li>• The construction entrance should be stabilized where traffic will be leaving the construction site and traveling on paved roads or other paved areas within 1,000 feet of the site.</li><li>• Provide for periodic street cleaning to remove any sediment that may have been tracked out. Sediment should be removed by shoveling or sweeping and carefully removed to a suitable disposal area where it will not be re-eroded.</li><li>• Utility trenches that run up and down slopes must be backfilled within seven days. Cross-slope trenches may remain open throughout construction to provide runoff interception and sediment trapping, provided that they do not convey turbid runoff off site.</li></ul>

## 4.2 Runoff Conveyance and Treatment BMPs

### BMP C200: Interceptor Dike and Swale

**Purpose**

Provide a ridge of compacted soil, or a ridge with an upslope swale, at the top or base of a disturbed slope or along the perimeter of a disturbed construction area to convey stormwater. Use the dike and/or swale to intercept the runoff from unprotected areas and direct it to areas where erosion can be controlled. This can prevent storm runoff from entering the work area or sediment-laden runoff from leaving the construction site.

**Conditions of Use**

☐ Where the runoff from an exposed site or disturbed slope must be conveyed to an erosion control facility which can safely convey the stormwater.

- Locate upslope of a construction site to prevent runoff from entering disturbed area.
- When placed horizontally across a disturbed slope, it reduces the amount and velocity of runoff flowing down the slope.
- Locate downslope to collect runoff from a disturbed area and direct it to a sediment basin.

**Design and Installation Specifications**

- Dike and/or swale and channel must be stabilized with temporary or permanent vegetation or other channel protection during construction.
- Channel requires a positive grade for drainage, steeper grades require channel protection and check dams.
- Review construction for areas where overtopping may occur.
- Can be used at top of new fill before vegetation is established.
- May be used as a permanent diversion channel to carry the runoff.
- Sub-basin tributary area should be one acre or less.
- Design capacity for 10-year, 24-hour storm for temporary facilities, 25-year, 24-hour storm for permanent facilities.

**Interceptor dikes** shall meet the following criteria:

- Top Width      2 feet minimum.
- Height          1.5 feet minimum on berm.
- Side Slope      2:1 or flatter.
- Grade            Depends on topography, however, dike system minimum is 0.5%, maximum is 1%.
- Compaction    Minimum of 90 percent ASTM D698 standard proctor.

Horizontal Spacing of Interceptor Dikes:

Average Slope	Slope Percent	Flowpath Length
20H:1V or less	3-5%	300 feet
(10 to 20)H:1V	5-10%	200 feet
(4 to 10)H:1V	10-25%	100 feet
(2 to 4)H:1V	25-50%	50 feet

Stabilization depends on velocity and reach.

Slopes <5% Seed and mulch applied within 5 days of dike construction (see *BMP C121, Mulching*).

Slopes 5 - 40% Dependent on runoff velocities and dike materials. Stabilization should be done immediately using either sod or riprap or other measures to avoid erosion.

- The upslope side of the dike shall provide positive drainage to the dike outlet. No erosion shall occur at the outlet. Provide energy dissipation measures as necessary. Sediment-laden runoff must be released through a sediment trapping facility.
- Minimize construction traffic over temporary dikes. Use temporary cross culverts for channel crossing.

**Interceptor swales** shall meet the following criteria:

Bottom Width	2 feet minimum; the bottom shall be level.
Depth	1-foot minimum.
Side Slope	2:1 or flatter.
Grade	Maximum 5 percent, with positive drainage to a suitable outlet (such as a sediment pond).

Stabilization Seed as per *BMP C120, Temporary and Permanent Seeding*, or *BMP C202, Channel Lining*, 12 inches thick of riprap pressed into the bank and extending at least 8 inches vertical from the bottom.

- Inspect diversion dikes and interceptor swales once a week and after every rainfall. Immediately remove sediment from the flow area.
- Damage caused by construction traffic or other activity must be repaired before the end of each working day.
- Check outlets and make timely repairs as needed to avoid gully formation. When the area below the temporary diversion dike is permanently stabilized, remove the dike and fill and stabilize the channel to blend with the natural surface.



## BMP C201: Grass-Lined Channels

**Purpose** To provide a channel with a vegetative lining for conveyance of runoff. See Figure 4.9 for typical grass-lined channels.

**Conditions of Use**  This practice applies to construction sites where concentrated runoff needs to be contained to prevent erosion or flooding.

- When a vegetative lining can provide sufficient stability for the channel cross section and at lower velocities of water (normally dependent on grade). This means that the channel slopes are generally less than 5 percent and space is available for a relatively large cross section.
- Typical uses include roadside ditches, channels at property boundaries, outlets for diversions, and other channels and drainage ditches in low areas.
- Channels that will be vegetated should be installed before major earthwork and hydroseeded with a **bonded fiber mulch (BFM)**. The vegetation should be well established (i.e., 75 percent cover) before water is allowed to flow in the ditch. With channels that will have high flows, erosion control blankets should be installed over the hydroseed. If vegetation cannot be established from seed before water is allowed in the ditch, sod should be installed in the bottom of the ditch in lieu of hydromulch and blankets.

**Design and Installation Specifications**  Locate the channel where it can conform to the topography and other features such as roads.

- Locate them to use natural drainage systems to the greatest extent possible.
- Avoid sharp changes in alignment or bends and changes in grade.
- Do not reshape the landscape to fit the drainage channel.
- Design velocities are to be below 5 ft/sec.; however, the design velocity should be based on soil conditions, type of vegetation, and method of establishment.
- An **established** grass or vegetated lining is required before the channel can be used to convey stormwater, unless stabilized with nets or blankets.
- If design velocity of a channel to be vegetated by seeding exceeds 2 ft/sec, a temporary channel liner is required. Geotextile or special mulch protection such as fiberglass roving or straw and netting provide stability until the vegetation is fully established. See Figure 4.10.
- Check dams shall be removed when the grass has matured sufficiently to protect the ditch or swale unless the slope of the swale is greater than 4 percent. The area beneath the check dams shall be seeded and mulched immediately after dam removal.

- If vegetation is established by sodding, the permissible velocity for established vegetation may be used and no temporary liner is needed.
- Do not subject grass-lined channel to sedimentation from disturbed areas. Use sediment-trapping BMPs upstream of the channel.
- **V-shaped grass channels** generally apply where the quantity of water is small, such as in short reaches along roadsides. The V-shaped cross section is least desirable because it is difficult to stabilize the bottom where velocities may be high.
- **Trapezoidal grass channels** are used where runoff volumes are large and slope is low so that velocities are nonerosive to vegetated linings. (Note: it is difficult to construct small parabolic shaped channels.)
- Subsurface drainage, or riprap channel bottoms, may be necessary on sites that are subject to prolonged wet conditions due to long duration flows or a high water table.
- Provide outlet protection at culvert ends and at channel intersections.
- Grass channels, at a minimum, should carry peak runoff for temporary construction drainage facilities from the 10-year, 24-hour storm without eroding. Where flood hazard exists, increase the capacity according to the potential damage.
- Grassed channel side slopes generally are constructed 3:1 or flatter to aid in the establishment of vegetation and for maintenance.
- Construct channels a minimum of 0.2 foot larger around the periphery to allow for soil bulking during seedbed preparations and sod buildup.

**Maintenance Standards**

☐ During the establishment period, check grass-lined channels after every rainfall.

- After grass is established, periodically check the channel; check it after every heavy rainfall event. Immediately make repairs.
- It is particularly important to check the channel outlet and all road crossings for bank stability and evidence of piping or scour holes.
- Remove all significant sediment accumulations to maintain the designed carrying capacity. Keep the grass in a healthy, vigorous condition at all times, since it is the primary erosion protection for the channel

## **BMP C202: Channel Lining**

### **Purpose**

To protect erodible channels by providing a channel liner using either blankets or riprap.

### **Conditions of Use**

☐ When natural soils or vegetated stabilized soils in a channel are not adequate to prevent channel erosion.

- When a permanent ditch or pipe system is to be installed and a temporary measure is needed.
- In almost all cases, synthetic and organic coconut blankets are more effective than riprap for protecting channels from erosion. Blankets can be used with and without vegetation. Blanketed channels can be designed to handle any expected flow and longevity requirement. Some synthetic blankets have a predicted life span of 50 years or more, even in sunlight.
- Other reasons why blankets are better than rock include the availability of blankets over rock. In many areas of the state, rock is not easily obtainable or is very expensive to haul to a site. Blankets can be delivered anywhere. Rock requires the use of dump trucks to haul and heavy equipment to place. Blankets usually only require laborers with hand tools, and sometimes a backhoe.
- The Federal Highway Administration recommends not using flexible liners whenever the slope exceeds 10 percent or the shear stress exceeds 8 lbs/ft<sup>2</sup>.

### **Design and Installation Specifications**

☐ See BMP C122 for information on blankets.

☐ Since riprap is used where erosion potential is high, construction must be sequenced so that the riprap is put in place with the minimum possible delay.

- Disturbance of areas where riprap is to be placed should be undertaken only when final preparation and placement of the riprap can follow immediately behind the initial disturbance. Where riprap is used for outlet protection, the riprap should be placed before or in conjunction with the construction of the pipe or channel so that it is in place when the pipe or channel begins to operate.
- The designer, after determining the riprap size that will be stable under the flow conditions, shall consider that size to be a minimum size and then, based on riprap gradations actually available in the area, select the size or sizes that equal or exceed the minimum size. The possibility of drainage structure damage by children shall be considered in selecting a riprap size, especially if there is nearby water or a gully in which to toss the stones.
- Stone for riprap shall consist of field stone or quarry stone of approximately rectangular shape. The stone shall be hard and angular and of such quality that it will not disintegrate on exposure to water or weathering and it shall be suitable in all respects for the purpose intended.

- Rubble concrete may be used provided it has a density of at least 150 pounds per cubic foot, and otherwise meets the requirement of this standard and specification.
- A lining of engineering filter fabric (geotextile) shall be placed between the riprap and the underlying soil surface to prevent soil movement into or through the riprap. The geotextile should be keyed in at the top of the bank.
- Filter fabric shall not be used on slopes greater than 1-1/2:1 as slippage may occur. It should be used in conjunction with a layer of coarse aggregate (granular filter blanket) when the riprap to be placed is 12 inches and larger.

## BMP C203: Water Bars

### **Purpose**

A small ditch or ridge of material is constructed diagonally across a road or right-of-way to divert stormwater runoff from the road surface, wheel tracks, or a shallow road ditch.

### **Conditions of Use**

☐ Clearing right-of-way and construction of access for power lines, pipelines, and other similar installations often require long narrow right-of-ways over sloping terrain. Disturbance and compaction promotes gully formation in these cleared strips by increasing the volume and velocity of runoff. Gully formation may be especially severe in tire tracks and ruts. To prevent gulying, runoff can often be diverted across the width of the right-of-way to undisturbed areas by using small predesigned diversions.

- Give special consideration to each individual outlet area, as well as to the cumulative effect of added diversions. Use gravel to stabilize the diversion where significant vehicular traffic is anticipated.

### **Design and Installation Specifications**

☐ Height: 8-inch minimum measured from the channel bottom to the ridge top.

- Side slope of channel: 2:1 maximum; 3:1 or flatter when vehicles will cross.
- Base width of ridge: 6-inch minimum.
- Locate them to use natural drainage systems and to discharge into well vegetated stable areas.
- Guideline for Spacing:

<b>Slope %</b>	<b>Spacing (ft)</b>
< 5	125
5 - 10	100
10 - 20	75
20 – 35	50
> 35	Use rock lined ditch

- Grade of water bar and angle: Select angle that results in ditch slope less than 2 percent.
- Install as soon as the clearing and grading is complete. Reconstruct when construction is complete on a section when utilities are being installed.
- Compact the ridge when installed.
- Stabilize, seed and mulch the portions that are not subject to traffic. Gravel the areas crossed by vehicles.

**Maintenance  
Standards**

☐ Periodically inspect right-of-way diversions for wear and after every heavy rainfall for erosion damage.

- Immediately remove sediment from the flow area and repair the dike.
- Check outlet areas and make timely repairs as needed.
- When permanent road drainage is established and the area above the temporary right-of-way diversion is permanently stabilized, remove the dike and fill the channel to blend with the natural ground, and appropriately stabilize the disturbed area.

## **BMP C204: Pipe Slope Drains**

**Purpose** To use a pipe to convey stormwater anytime water needs to be diverted away from or over bare soil to prevent gullies, channel erosion, and saturation of slide-prone soils.

**Conditions of Use** Pipe slope drains should be used when a temporary or permanent stormwater conveyance is needed to move the water down a steep slope to avoid erosion (Figure 4.11).

On highway projects, they should be used at bridge ends to collect runoff and pipe it to the base of the fill slopes along bridge approaches. These can be designed into a project and included as bid items. Another use on road projects is to collect runoff from pavement and pipe it away from side slopes. These are useful because there is generally a time lag between having the first lift of asphalt installed and the curbs, gutters, and permanent drainage installed. Used in conjunction with sand bags, or other temporary diversion devices, these will prevent massive amounts of sediment from leaving a project.

Water can be collected, channeled with sand bags, Triangular Silt Dikes, berms, or other material, and piped to temporary sediment ponds.

Pipe slope drains can be:

- Connected to new catch basins and used temporarily until all permanent piping is installed;
- Used to drain water collected from aquifers exposed on cut slopes and take it to the base of the slope;
- Used to collect clean runoff from plastic sheeting and direct it away from exposed soil;
- Installed in conjunction with silt fence to drain collected water to a controlled area;
- Used to divert small seasonal streams away from construction. They have been used successfully on culvert replacement and extension jobs. Large flex pipe can be used on larger streams during culvert removal, repair, or replacement; and,
- Connected to existing down spouts and roof drains and used to divert water away from work areas during building renovation, demolition, and construction projects.

There are now several commercially available collectors that are attached to the pipe inlet and help prevent erosion at the inlet.

**Design and  
Installation  
Specifications**

☐ Size the pipe to convey the flow. The capacity for temporary drains shall be sufficient to handle the peak flow from a 10-year, 24-hour storm event. Permanent pipe slope drains shall be sized for the 25-year, 24-hour peak flow.

- Use care in clearing vegetated slopes for installation.
- Re-establish cover immediately on areas disturbed by installation.
- Use temporary drains on new cut or fill slopes.
- Use diversion dikes or swales to collect water at the top of the slope.
- Ensure that the entrance area is stable and large enough to direct flow into the pipe.
- Piping of water through the berm at the entrance area is a common failure mode.
- The entrance shall consist of a standard flared end section for culverts 12 inches and larger with a minimum 6-inch metal toe plate to prevent runoff from undercutting the pipe inlet. The slope of the entrance shall be at least 3 percent. Sand bags may also be used at pipe entrances as a temporary measure.
- The soil around and under the pipe and entrance section shall be thoroughly compacted to prevent undercutting.
- The flared inlet section shall be securely connected to the slope drain and have watertight connecting bands.
- Slope drain sections shall be securely fastened together, fused or have gasketed watertight fittings, and shall be securely anchored into the soil.
- Thrust blocks should be installed anytime 90 degree bends are utilized. Depending on size of pipe and flow, these can be constructed with sand bags, straw bales staked in place, “t” posts and wire, or ecology blocks.
- Pipe needs to be secured along its full length to prevent movement. This can be done with steel “t” posts and wire. A post is installed on each side of the pipe and the pipe is wired to them. This should be done every 10-20 feet of pipe length or so, depending on the size of the pipe and quantity of water to diverted.
- Interceptor dikes shall be used to direct runoff into a slope drain. The height of the dike shall be at least 1 foot higher at all points than the top of the inlet pipe.
- The area below the outlet must be stabilized with a riprap apron (see BMP C209 Outlet Protection, for the appropriate outlet material).
- If the pipe slope drain is conveying sediment-laden water, direct all flows into the sediment trapping facility.
- Materials specifications for any permanent piped system shall be set by the local government.



**Maintenance  
Standards**

☐ Check inlet and outlet points regularly, especially after storms.


☐ The inlet should be free of undercutting, and no water should be going around the point of entry. If there are problems, the headwall should be reinforced with compacted earth or sand bags.

- The outlet point should be free of erosion and installed with appropriate outlet protection.
- For permanent installations, inspect pipe periodically for vandalism and physical distress such as slides and wind-throw.
- Normally the pipe slope is so steep that clogging is not a problem with smooth wall pipe, however, debris may become lodged in the pipe.

## **BMP C205: Subsurface Drains**

**Purpose** To intercept, collect, and convey ground water to a satisfactory outlet, using a perforated pipe or conduit below the ground surface. Subsurface drains are also known as “french drains.” The perforated pipe provides a dewatering mechanism to drain excessively wet soils, provide a stable base for construction, improve stability of structures with shallow foundations, or to reduce hydrostatic pressure to improve slope stability.

**Conditions of Use** Use when excessive water must be removed from the soil. The soil permeability, depth to water table and impervious layers are all factors which may govern the use of subsurface drains.

**Design and Installation Specifications**  **Relief drains** are used either to lower the water table in large, relatively flat areas, improve the growth of vegetation, or to remove surface water.

They are installed along a slope and drain in the direction of the slope.

They can be installed in a grid pattern, a herringbone pattern, or a random pattern.

- **Interceptor drains** are used to remove excess ground water from a slope, stabilize steep slopes, and lower the water table immediately below a slope to prevent the soil from becoming saturated.

They are installed perpendicular to a slope and drain to the side of the slope.

They usually consist of a single pipe or series of single pipes instead of a patterned layout.

- **Depth and spacing of interceptor drains** - The depth of an interceptor drain is determined primarily by the depth to which the water table is to be lowered or the depth to a confining layer. For practical reasons, the maximum depth is usually limited to 6 feet, with a minimum cover of 2 feet to protect the conduit.
- The soil should have depth and sufficient permeability to permit installation of an effective drainage system at a depth of 2 to 6 feet.
- An adequate outlet for the drainage system must be available either by gravity or by pumping.
- The quantity and quality of discharge needs to be accounted for in the receiving stream (additional detention may be required).
- This standard does not apply to subsurface drains for building foundations or deep excavations.
- The capacity of an interceptor drain is determined by calculating the maximum rate of ground water flow to be intercepted. Therefore, it is good practice to make complete subsurface investigations, including hydraulic conductivity of the soil, before designing a subsurface drainage system.
- **Size of drain**--Size subsurface drains to carry the required capacity without pressure flow. Minimum diameter for a subsurface drain is 4 inches.

- The minimum velocity required to prevent silting is 1.4 ft./sec. The line shall be graded to achieve this velocity at a minimum. The maximum allowable velocity using a sand-gravel filter or envelope is 9 ft/sec.
- Filter material and fabric shall be used around all drains for proper bedding and filtration of fine materials. Envelopes and filters should surround the drain to a minimum of 3-inch thickness.
- The outlet of the subsurface drain shall empty into a sediment pond through a catch basin. If free of sediment, it can then empty into a receiving channel, swale, or stable vegetated area adequately protected from erosion and undermining.
- The trench shall be constructed on a continuous grade with no reverse grades or low spots.
- Soft or yielding soils under the drain shall be stabilized with gravel or other suitable material.
- Backfilling shall be done immediately after placement of the pipe. No sections of pipe shall remain uncovered overnight or during a rainstorm. Backfill material shall be placed in the trench in such a manner that the drain pipe is not displaced or damaged.
- Do not install permanent drains near trees to avoid the tree roots that tend to clog the line. Use solid pipe with watertight connections where it is necessary to pass a subsurface drainage system through a stand of trees.
- **Outlet**--Ensure that the outlet of a drain empties into a channel or other watercourse above the normal water level.
- Secure an animal guard to the outlet end of the pipe to keep out rodents.
- Use outlet pipe of corrugated metal, cast iron, or heavy-duty plastic without perforations and at least 10 feet long. Do not use an envelope or filter material around the outlet pipe, and bury at least two-thirds of the pipe length.
- When outlet velocities exceed those allowable for the receiving stream, outlet protection must be provided.

**Maintenance Standards**

- ☐ Subsurface drains shall be checked periodically to ensure that they are free-flowing and not clogged with sediment or roots.
- The outlet shall be kept clean and free of debris.
- Surface inlets shall be kept open and free of sediment and other debris.
- Trees located too close to a subsurface drain often clog the system with their roots. If a drain becomes clogged, relocate the drain or remove the trees as a last resort. Drain placement should be planned to minimize this problem.
- Where drains are crossed by heavy vehicles, the line shall be checked to ensure that it is not crushed.

## **BMP C206: Level Spreader**

### **Purpose**

To provide a temporary outlet for dikes and diversions consisting of an excavated depression constructed at zero grade across a slope. To convert concentrated runoff to sheet flow and release it onto areas stabilized by existing vegetation or an engineered filter strip.

### **Conditions of Use**

Used when a concentrated flow of water needs to be dispersed over a large area with existing stable vegetation.

- Items to consider are:
  1. What is the risk of erosion or damage if the flow may become concentrated?
  2. Is an easement required if discharged to adjoining property?
  3. Most of the flow should be as ground water and not as surface flow.
  4. Is there an unstable area downstream that cannot accept additional ground water?
- Use only where the slopes are gentle, the water volume is relatively low, and the soil will adsorb most of the low flow events.

### **Design and Installation Specifications**

Use above undisturbed areas that are stabilized by existing vegetation.

If the level spreader has any low points, flow will concentrate, create channels and may cause erosion.

- Discharge area below the outlet must be uniform with a slope of less than 5H:1V.
- Outlet to be constructed level in a stable, undisturbed soil profile (not on fill).
- The runoff shall not reconcentrate after release unless intercepted by another downstream measure.
- The grade of the channel for the last 20 feet of the dike or interceptor entering the level spreader shall be less than or equal to 1 percent. The grade of the level spreader shall be 0 percent to ensure uniform spreading of storm runoff.
- A 6-inch high gravel berm placed across the level lip shall consist of washed crushed rock, 2- to 4-inch or 3/4-inch to 1½-inch size.
- The spreader length shall be determined by estimating the peak flow expected from the 10-year, 24-hour design storm. The length of the spreader shall be a minimum of 15 feet for 0.1 cfs and shall be 10 feet for each 0.1 cfs there after to a maximum of 0.5 cfs per spreader. Use multiple spreaders for higher flows.
- The width of the spreader should be at least 6 feet.
- The depth of the spreader as measured from the lip should be at least 6 inches and it should be uniform across the entire length.

**Maintenance  
Standards**

- Level spreaders shall be setback from the property line unless there is an easement for flow.
  - Level spreaders, when installed every so often in grassy swales, keep the flows from concentrating. Materials that can be used include sand bags, lumber, logs, concrete, and pipe. To function properly, the material needs to be installed level and on contour. Figures 4.12 and 4.13 provide a cross-section and a detail of a level spreader.
- ☐ The spreader should be inspected after every runoff event to ensure that it is functioning correctly.
- The contractor should avoid the placement of any material on the structure and should prevent construction traffic from crossing over the structure.
  - If the spreader is damaged by construction traffic, it shall be immediately repaired.

## **BMP C207: Check Dams**

<b>Purpose</b>	Construction of small dams across a swale or ditch reduces the velocity of concentrated flow and dissipates energy at the check dam.
<b>Conditions of Use</b>	<p>☐ Where temporary channels or permanent channels are not yet vegetated, channel lining is infeasible, and velocity checks are required.</p> <ul style="list-style-type: none"><li>• Check dams may not be placed in streams unless approved by the State Department of Fish and Wildlife. Check dams may not be placed in wetlands without approval from a permitting agency.</li><li>• Check dams shall not be placed below the expected backwater from any salmonid bearing water between October 1 and May 31 to ensure that there is no loss of high flow refuge habitat for overwintering juvenile salmonids and emergent salmonid fry.</li></ul>
<b>Design and Installation Specifications</b>	<p>☐ Whatever material is used, the dam should form a triangle when viewed from the side. This prevents undercutting as water flows over the face of the dam rather than falling directly onto the ditch bottom.</p> <p>☐ Check dams in association with sumps work more effectively at slowing flow and retaining sediment than just a check dam alone. A deep sump should be provided immediately upstream of the check dam.</p> <ul style="list-style-type: none"><li>• In some cases, if carefully located and designed, check dams can remain as permanent installations with very minor regrading. They may be left as either spillways, in which case accumulated sediment would be graded and seeded, or as check dams to prevent further sediment from leaving the site.</li><li>• Check dams can be constructed of either rock or pea-gravel filled bags. Numerous new products are also available for this purpose. They tend to be re-usable, quick and easy to install, effective, and cost efficient.</li><li>• Check dams should be placed perpendicular to the flow of water.</li><li>• The maximum spacing between the dams shall be such that the toe of the upstream dam is at the same elevation as the top of the downstream dam.</li><li>• Keep the maximum height at 2 feet at the center of the dam.</li><li>• Keep the center of the check dam at least 12 inches lower than the outer edges at natural ground elevation.</li><li>• Keep the side slopes of the check dam at 2:1 or flatter.</li><li>• Key the stone into the ditch banks and extend it beyond the abutments a minimum of 18 inches to avoid washouts from overflow around the dam.</li><li>• Use filter fabric foundation under a rock or sand bag check dam. If a blanket ditch liner is used, this is not necessary. A piece of organic or synthetic blanket cut to fit will also work for this purpose.</li></ul>

- Rock check dams shall be constructed of appropriately sized rock. The rock must be placed by hand or by mechanical means (no dumping of rock to form dam) to achieve complete coverage of the ditch or swale and to ensure that the center of the dam is lower than the edges. The rock used must be large enough to stay in place given the expected design flow through the channel.
- In the case of grass-lined ditches and swales, all check dams and accumulated sediment shall be removed when the grass has matured sufficiently to protect the ditch or swale - unless the slope of the swale is greater than 4 percent. The area beneath the check dams shall be seeded and mulched immediately after dam removal.
- Ensure that channel appurtenances, such as culvert entrances below check dams, are not subject to damage or blockage from displaced stones. Figure 4.14 depicts a typical rock check dam.

**Maintenance Standards**

☐ Check dams shall be monitored for performance and sediment accumulation during and after each runoff producing rainfall. Sediment shall be removed when it reaches one half the sump depth.

- Anticipate submergence and deposition above the check dam and erosion from high flows around the edges of the dam.
- If significant erosion occurs between dams, install a protective riprap liner in that portion of the channel.

## **BMP C208: Triangular Silt Dike (Geotextile-Encased Check Dam)**

**Purpose** Triangular silt dikes may be used as check dams, for perimeter protection, for temporary soil stockpile protection, for drop inlet protection, or as a temporary interceptor dike.

**Conditions of Use** ☐ May be used in place of straw bales for temporary check dams in ditches of any dimension.

- May be used on soil or pavement with adhesive or staples.
- TSDs have been used to build temporary:
  1. sediment ponds;
  2. diversion ditches;
  3. concrete wash out facilities;
  4. curbing;
  5. water bars;
  6. level spreaders; and,
  7. berms.

### **Design and Installation Specifications**

☐ Made of urethane foam sewn into a woven geosynthetic fabric.

☐ It is triangular, 10 inches to 14 inches high in the center, with a 20-inch to 28-inch base. A 2-foot apron extends beyond both sides of the triangle along its standard section of 7 feet. A sleeve at one end allows attachment of additional sections as needed.

- Install with ends curved up to prevent water from flowing around the ends.
- The fabric flaps and check dam units are attached to the ground with wire staples. Wire staples should be No. 11 gauge wire and should be 200 mm to 300 mm in length.
- When multiple units are installed, the sleeve of fabric at the end of the unit shall overlap the abutting unit and be stapled.
- Check dams should be located and installed as soon as construction will allow.
- Check dams should be placed perpendicular to the flow of water.
- When used as check dams, the leading edge must be secured with rocks, sandbags, or a small key slot and staples.
- In the case of grass-lined ditches and swales, check dams and accumulated sediment shall be removed when the grass has matured sufficiently to protect the ditch or swale unless the slope of the swale is greater than 4 percent. The area beneath the check dams shall be seeded and mulched immediately after dam removal.

### **Maintenance Standards**

☐ Triangular silt dams shall be monitored for performance and sediment accumulation during and after each runoff producing rainfall. Sediment shall be removed when it reaches one half the height of the dam.

- Anticipate submergence and deposition above the triangular silt dam and erosion from high flows around the edges of the dam. Immediately repair any damage or any undercutting of the dam.



## BMP C209: Outlet Protection

**Purpose** Outlet protection prevents scour at conveyance outlets and minimizes the potential for downstream erosion by reducing the velocity of concentrated stormwater flows.

**Conditions of Use** Outlet protection is required at the outlets of all ponds, pipes, ditches, or other conveyances, and where runoff is conveyed to a natural or manmade drainage feature such as a stream, wetland, lake, or ditch.

### **Design and Installation Specifications**

☐ The receiving channel at the outlet of a culvert shall be protected from erosion by rock lining a minimum of 6 feet downstream and extending up the channel sides a minimum of 1-foot above the maximum tailwater elevation or 1-foot above the crown, whichever is higher. For large pipes (more than 18 inches in diameter), the outlet protection lining of the channel is lengthened to four times the diameter of the culvert.

- Standard wingwalls, and tapered outlets and paved channels should also be considered when appropriate for permanent culvert outlet protection. (See ~~the~~ WSDOT Hydraulic Manual, [available through WSDOT Engineering Publications](#)).
- Organic or synthetic erosion blankets, with or without vegetation, are usually more effective than rock, cheaper, and easier to install. Materials can be chosen using manufacturer product specifications. ASTM test results are available for most products and the designer can choose the correct material for the expected flow.
- With low flows, vegetation (including sod) can be effective.
- The following guidelines shall be used for riprap outlet protection:
  1. If the discharge velocity at the outlet is less than 5 fps (pipe slope less than 1 percent), use 2-inch to 8-inch riprap. Minimum thickness is 1-foot.
  2. For 5 to 10 fps discharge velocity at the outlet (pipe slope less than 3 percent), use 24-inch to 4-foot riprap. Minimum thickness is 2 feet.
  3. For outlets at the base of steep slope pipes (pipe slope greater than 10 percent), an engineered energy dissipater shall be used.
- Filter fabric or erosion control blankets should always be used under riprap to prevent scour and channel erosion.
- New pipe outfalls can provide an opportunity for low-cost fish habitat improvements. For example, an alcove of low-velocity water can be created by constructing the pipe outfall and associated energy dissipater back from the stream edge and digging a channel, overwidened to the upstream side, from the outfall. Overwintering juvenile and migrating adult salmonids may use the alcove as shelter during high flows. Bank stabilization, bioengineering, and habitat features may be required for disturbed areas. See Volume V for more information on outfall system design.

**Maintenance  
Standards**

- Inspect and repair as needed.
- Add rock as needed to maintain the intended function.
- Clean energy dissipater if sediment builds up.

## **BMP C220: Storm Drain Inlet Protection**

**Purpose** To prevent coarse sediment from entering drainage systems prior to permanent stabilization of the disturbed area.

**Conditions of Use** Where storm drain inlets are to be made operational before permanent stabilization of the disturbed drainage area. Protection should be provided for all storm drain inlets downslope and within 500 feet of a disturbed or construction area, unless the runoff that enters the catch basin will be conveyed to a sediment pond or trap. Inlet protection may be used anywhere to protect the drainage system. It is likely that the drainage system will still require cleaning.

Table 4.9 lists several options for inlet protection. All of the methods for storm drain inlet protection are prone to plugging and require a high frequency of maintenance. Drainage areas should be limited to 1 acre or less. Emergency overflows may be required where stormwater ponding would cause a hazard. If an emergency overflow is provided, additional end-of-pipe treatment may be required.

### **Design and Installation Specifications**

*Excavated Drop Inlet Protection* - An excavated impoundment around the storm drain. Sediment settles out of the stormwater prior to entering the storm drain.

- Depth 1-2 ft as measured from the crest of the inlet structure.
- Side Slopes of excavation no steeper than 2:1.
- Minimum volume of excavation 35 cubic yards.
- Shape basin to fit site with longest dimension oriented toward the longest inflow area.
- Install provisions for draining to prevent standing water problems.
- Clear the area of all debris.
- Grade the approach to the inlet uniformly.
- Drill weep holes into the side of the inlet.
- Protect weep holes with screen wire and washed aggregate.
- Seal weep holes when removing structure and stabilizing area.
- It may be necessary to build a temporary dike to the down slope side of the structure to prevent bypass flow.

*Block and Gravel Filter* - A barrier formed around the storm drain inlet with standard concrete blocks and gravel. See Figure 4.15.

- Height 1 to 2 feet above inlet.
- Recess the first row 2 inches into the ground for stability.
- Support subsequent courses by placing a 2x4 through the block opening.
- Do not use mortar.
- Lay some blocks in the bottom row on their side for dewatering the pool.

- Place hardware cloth or comparable wire mesh with ½-inch openings over all block openings.
- Place gravel just below the top of blocks on slopes of 2:1 or flatter.
- An alternative design is a gravel donut.
- Inlet slope of 3:1.
- Outlet slope of 2:1.
- 1-foot wide level stone area between the structure and the inlet.
- Inlet slope stones 3 inches in diameter or larger.
- Outlet slope use gravel ½- to ¾-inch at a minimum thickness of 1-foot.

*Gravel and Wire Mesh Filter* - A gravel barrier placed over the top of the inlet. This structure does not provide an overflow.

- Hardware cloth or comparable wire mesh with ½-inch openings.
- Coarse aggregate.
- Height 1-foot or more, 18 inches wider than inlet on all sides.
- Place wire mesh over the drop inlet so that the wire extends a minimum of 1-foot beyond each side of the inlet structure.
- If more than one strip of mesh is necessary, overlap the strips.
- Place coarse aggregate over the wire mesh.
- The depth of the gravel should be at least 12 inches over the entire inlet opening and extend at least 18 inches on all sides.

*Catchbasin Filters* - Inserts should be designed by the manufacturer for use at construction sites. The limited sediment storage capacity increases the amount of inspection and maintenance required, which may be daily for heavy sediment loads. The maintenance requirements can be reduced by combining a catchbasin filter with another type of inlet protection. This type of inlet protection provides flow bypass without overflow and therefore may be a better method for inlets located along active rights-of-way.

- 5 cubic feet of storage.
- Dewatering provisions.
- High-flow bypass that will not clog under normal use at a construction site.
- The catchbasin filter is inserted in the catchbasin just below the grating.

*Curb Inlet Protection with Wooden Weir* – Barrier formed around a curb inlet with a wooden frame and gravel.

- ☐ Wire mesh with ½-inch openings.
- ☐ Extra strength filter cloth.
- ☐ Construct a frame.
- Attach the wire and filter fabric to the frame.
- Pile coarse washed aggregate against wire/fabric.

- Place weight on frame anchors.

*Block and Gravel Curb Inlet Protection* – Barrier formed around an inlet with concrete blocks and gravel. See Figure 4.16.

☐ Wire mesh with ½-inch openings.

☐ Place two concrete blocks on their sides abutting the curb at either side of the inlet opening. These are spacer blocks.

- Place a 2x4 stud through the outer holes of each spacer block to align the front blocks.
- Place blocks on their sides across the front of the inlet and abutting the spacer blocks.
- Place wire mesh over the outside vertical face.
- Pile coarse aggregate against the wire to the top of the barrier.

*Curb and Gutter Sediment Barrier* – Sandbag or rock berm (riprap and aggregate) 3 feet high and 3 feet wide in a horseshoe shape. See Figure 4.17.

☐ Construct a horseshoe shaped berm, faced with coarse aggregate if using riprap, 3 feet high and 3 feet wide, at least 2 feet from the inlet.

- Construct a horseshoe shaped sedimentation trap on the outside of the berm sized to sediment trap standards for protecting a culvert inlet.

**Maintenance Standards**

☐ Catch basin filters should be inspected frequently, especially after storm events. If the insert becomes clogged, it should be cleaned or replaced.

- For systems using stone filters: If the stone filter becomes clogged with sediment, the stones must be pulled away from the inlet and cleaned or replaced. Since cleaning of gravel at a construction site may be difficult, an alternative approach would be to use the clogged stone as fill and put fresh stone around the inlet.
- Do not wash sediment into storm drains while cleaning. Spread all excavated material evenly over the surrounding land area or stockpile and stabilize as appropriate.

## BMP C230: Straw Bale Barrier

### **Purpose**

To decrease the velocity of sheet flows and intercept and detain small amounts of sediment from disturbed areas of limited extent, preventing sediment from leaving the site. See Figure 4.18 for details on straw bale barriers.

### **Conditions of Use**

☐ Below disturbed areas subject to sheet and rill erosion.

- Straw bales are among the most used and **least effective BMPs**. The best use of a straw bale is hand spread on the site.
- Where the size of the drainage area is no greater than 1/4 acre per 100 feet of barrier length; the maximum slope length behind the barrier is 100 feet; and the maximum slope gradient behind the barrier is 2:1.
- Where effectiveness is required for less than three months.
- **Under no circumstances should straw bale barriers be constructed in streams, channels, or ditches.**
- Straw bale barriers should not be used where rock or hard surfaces prevent the full and uniform anchoring of the barrier.

### **Design and Installation Specifications**

☐ Bales shall be placed in a single row, lengthwise on the contour, with ends of adjacent bales tightly abutting one another.

☐ All bales shall be either wire-bound or string-tied. Straw bales shall be installed so that bindings are oriented around the sides rather than along the tops and bottoms of the bales in order to prevent deterioration of the bindings.

- The barrier shall be entrenched and backfilled. A trench shall be excavated the width of a bale and the length of the proposed barrier to a minimum depth of 4 inches. The trench must be deep enough to remove all grass and other material that might allow underflow. After the bales are staked and chinked (filled by wedging), the excavated soil shall be backfilled against the barrier. Backfill soil shall conform to the ground level on the downhill side and shall be built up to 4 inches against the uphill side of the barrier.
- Each bale shall be securely anchored by at least two stakes or re-bars driven through the bale. The first stake in each bale shall be driven toward the previously laid bale to force the bales together. Stakes or re-bars shall be driven deep enough into the ground to securely anchor the bales. Stakes should not extend above the bales but instead should be driven in flush with the top of the bale for safety reasons.
- The gaps between the bales shall be chinked (filled by wedging) with straw to prevent water from escaping between the bales. Loose straw scattered over the area immediately uphill from a straw bale barrier tends to increase barrier efficiency. Wedging must be done carefully in order not to separate the bales.

**Maintenance  
Standards**

☐ Straw bale barriers shall be inspected immediately after each runoff-producing rainfall and at least daily during prolonged rainfall.

- Close attention shall be paid to the repair of damaged bales, end runs, and undercutting beneath bales.
- Necessary repairs to barriers or replacement of bales shall be accomplished promptly.
- Sediment deposits should be removed after each runoff-producing rainfall. They must be removed when the level of deposition reaches approximately one-half the height of the barrier.
- Any sediment deposits remaining in place after the straw bale barrier is no longer required shall be dressed to conform to the existing grade, prepared and seeded.
- Straw bales used as a temporary straw bale barrier shall be removed after project completion and stabilization to prevent sprouting of unwanted vegetation.

## **BMP C231: Brush Barrier**

<b>Purpose</b>	The purpose of brush barriers is to reduce the transport of coarse sediment from a construction site by providing a temporary physical barrier to sediment and reducing the runoff velocities of overland flow.
<b>Conditions of Use</b>	<ul style="list-style-type: none"><li>☐ Brush barriers may be used downslope of all disturbed areas of less than one-quarter acre.</li><li>• Brush barriers are not intended to treat concentrated flows, nor are they intended to treat substantial amounts of overland flow. Any concentrated flows must be conveyed through the drainage system to a sediment pond. The only circumstance in which overland flow can be treated solely by a barrier, rather than by a sediment pond, is when the area draining to the barrier is small.</li><li>• Brush barriers should only be installed on contours.</li></ul>
<b>Design and Installation Specifications</b>	<ul style="list-style-type: none"><li>☐ Height 2 feet (minimum) to 5 feet (maximum).</li><li>☐ Width 5 feet at base (minimum) to 15 feet (maximum).</li><li>☐ Filter fabric (geotextile) may be anchored over the brush berm to enhance the filtration ability of the barrier. Ten-ounce burlap is an adequate alternative to filter fabric.</li><li>• Chipped site vegetation, composted mulch, or wood-based mulch (hog fuel) can be used to construct brush barriers.</li><li>• A 100 percent biodegradable installation can be constructed using 10-ounce burlap held in place by wooden stakes. Figure 4.12-19 depicts a typical brush barrier.</li></ul>
<b>Maintenance Standards</b>	<ul style="list-style-type: none"><li>☐ There shall be no signs of erosion or concentrated runoff under or around the barrier. If concentrated flows are bypassing the barrier, it must be expanded or augmented by toed-in filter fabric.</li><li>• The dimensions of the barrier must be maintained.</li></ul>



## **BMP C232: Gravel Filter Berm**

**Purpose** A gravel filter berm is constructed on rights-of-way or traffic areas within a construction site to retain sediment by using a filter berm of gravel or crushed rock.

**Conditions of Use** Where a temporary measure is needed to retain sediment from rights-of-way or in traffic areas on construction sites.

### **Design and Installation Specifications**

☐ Berm material shall be ¾ to 3 inches in size, washed well-grade gravel or crushed rock with less than 5 percent fines.

☐ Spacing of berms:

- Every 300 feet on slopes less than 5 percent
- Every 200 feet on slopes between 5 percent and 10 percent
- Every 100 feet on slopes greater than 10 percent

• Berm dimensions:

- 1 foot high with 3:1 side slopes
- 8 linear feet per 1 cfs runoff based on the 10-year, 24-hour design storm

### **Maintenance Standards**

☐ Regular inspection is required. Sediment shall be removed and filter material replaced as needed.

## BMP C233: Silt Fence

### **Purpose**

Use of a silt fence reduces the transport of coarse sediment from a construction site by providing a temporary physical barrier to sediment and reducing the runoff velocities of overland flow. See Figure 4.20 for details on silt fence construction.

### **Conditions of Use**

☐ Silt fence may be used downslope of all disturbed areas.

- Silt fence is not intended to treat concentrated flows, nor is it intended to treat substantial amounts of overland flow. Any concentrated flows must be conveyed through the drainage system to a sediment pond. The only circumstance in which overland flow can be treated solely by a silt fence, rather than by a sediment pond, is when the area draining to the fence is one acre or less and flow rates are less than 0.5 cfs.
- Silt fences should not be constructed in streams or used in V-shaped ditches. They are not an adequate method of silt control for anything deeper than sheet or overland flow.

### **Design and Installation Specifications**

☐ Drainage area of 1 acre or less or in combination with sediment basin in a larger site.

☐ Maximum slope steepness (normal (perpendicular) to fence line) 1:1.

- Maximum sheet or overland flow path length to the fence of 100 feet.
- No flows greater than 0.5 cfs.
- The geotextile used shall meet the following standards. All geotextile properties listed below are minimum average roll values (i.e., the test result for any sampled roll in a lot shall meet or exceed the values shown in Table 4.10):
- Standard strength fabrics shall be supported with wire mesh, chicken wire, 2-inch x 2-inch wire, safety fence, or jute mesh to increase the strength of the fabric. Silt fence materials are available that have synthetic mesh backing attached.
- Filter fabric material shall contain ultraviolet ray inhibitors and stabilizers to provide a minimum of six months of expected usable construction life at a temperature range of 0°F. to 120°F.
- 100 percent biodegradable silt fence is available that is strong, long lasting, and can be left in place after the project is completed, if permitted by local regulations.
- Standard Notes for construction plans and specifications follow. Refer to Figure 4.20 for standard silt fence details.

The contractor shall install and maintain temporary silt fences at the locations shown in the Plans. The silt fences shall be constructed in the areas of clearing, grading, or drainage prior to starting those activities. A silt fence shall not be considered temporary if the silt fence must function beyond the life of the contract. The silt fence shall prevent soil carried by runoff water from going beneath, through,

or over the top of the silt fence, but shall allow the water to pass through the fence.

The minimum height of the top of silt fence shall be 2 feet and the maximum height shall be 2½ feet above the original ground surface.

The geotextile shall be sewn together at the point of manufacture, or at an approved location as determined by the Engineer, to form geotextile lengths as required. All sewn seams shall be located at a support post. Alternatively, two sections of silt fence can be overlapped, provided the Contractor can demonstrate, to the satisfaction of the Engineer, that the overlap is long enough and that the adjacent fence sections are close enough together to prevent silt laden water from escaping through the fence at the overlap.

The geotextile shall be attached on the up-slope side of the posts and support system with staples, wire, or in accordance with the manufacturer's recommendations. The geotextile shall be attached to the posts in a manner that reduces the potential for geotextile tearing at the staples, wire, or other connection device. Silt fence back-up support for the geotextile in the form of a wire or plastic mesh is dependent on the properties of the geotextile selected for use. If wire or plastic back-up mesh is used, the mesh shall be fastened securely to the up-slope of the posts with the geotextile being up-slope of the mesh back-up support.

The geotextile at the bottom of the fence shall be buried in a trench to a minimum depth of 4 inches below the ground surface. The trench shall be backfilled and the soil tamped in place over the buried portion of the geotextile, such that no flow can pass beneath the fence and scouring can not occur. When wire or polymeric back-up support mesh is used, the wire or polymeric mesh shall extend into the trench a minimum of 3 inches.

The fence posts shall be placed or driven a minimum of 18 inches. A minimum depth of 12 inches is allowed if topsoil or other soft subgrade soil is not present and a minimum depth of 18 inches cannot be reached. Fence post depths shall be increased by 6 inches if the fence is located on slopes of 3:1 or steeper and the slope is perpendicular to the fence. If required post depths cannot be obtained, the posts shall be adequately secured by bracing or guying to prevent overturning of the fence due to sediment loading.

Silt fences shall be located on contour as much as possible, except at the ends of the fence, where the fence shall be turned uphill such that the silt fence captures the runoff water and prevents water from flowing around the end of the fence.

If the fence must cross contours, with the exception of the ends of the fence, gravel check dams placed perpendicular to the back of the fence shall be used to minimize concentrated flow and erosion along the back of the fence. The gravel check dams shall be approximately 1-foot deep at the back of the fence. It shall be continued perpendicular to the fence at the same elevation until the top of the

check dam intercepts the ground surface behind the fence. The gravel check dams shall consist of crushed surfacing base course, gravel backfill for walls, or shoulder ballast. The gravel check dams shall be located every 10 feet along the fence where the fence must cross contours. The slope of the fence line where contours must be crossed shall not be steeper than 3:1.

Wood, steel or equivalent posts shall be used. Wood posts shall have minimum dimensions of 2 inches by 2 inches by 3 feet minimum length, and shall be free of defects such as knots, splits, or gouges. Steel posts shall consist of either size No. 6 rebar or larger, ASTM A 120 steel pipe with a minimum diameter of 1-inch, U, T, L, or C shape steel posts with a minimum weight of 1.35 lbs./ft. or other steel posts having equivalent strength and bending resistance to the post sizes listed. The spacing of the support posts shall be a maximum of 6 feet.

Fence back-up support, if used, shall consist of steel wire with a maximum mesh spacing of 2 inches, or a prefabricated polymeric mesh. The strength of the wire or polymeric mesh shall be equivalent to or greater than 180 lbs. grab tensile strength. The polymeric mesh must be as resistant to ultraviolet radiation as the geotextile it supports.

- Silt fence installation using the slicing method specification details follow. Refer to Figure 4.21 for slicing method details.

The base of both end posts must be at least 2 to 4 inches above the top of the silt fence fabric on the middle posts for ditch checks to drain properly. Use a hand level or string level, if necessary, to mark base points before installation.

Install posts 3 to 4 feet apart in critical retention areas and 6 to 7 feet apart in standard applications.

Install posts 24 inches deep on the downstream side of the silt fence, and as close as possible to the fabric, enabling posts to support the fabric from upstream water pressure.

Install posts with the nipples facing away from the silt fence fabric.

Attach the fabric to each post with three ties, all spaced within the top 8 inches of the fabric. Attach each tie diagonally 45 degrees through the fabric, with each puncture at least 1 inch vertically apart. In addition, each tie should be positioned to hang on a post nipple when tightening to prevent sagging.

Wrap approximately 6 inches of fabric around the end posts and secure with 3 ties.

No more than 24 inches of a 36-inch fabric is allowed above ground level.

The rope lock system must be used in all ditch check applications.

The installation should be checked and corrected for any deviation before compaction. Use a flat-bladed shovel to tuck fabric deeper into the ground if necessary.

Compaction is vitally important for effective results. Compact the soil immediately next to the silt fence fabric with the front wheel of the tractor, skid steer, or roller exerting at least 60 pounds per square inch. Compact the upstream side first and then each side twice for a total of four trips.

**Maintenance  
Standards**

☐ Any damage shall be repaired immediately.

☐ If concentrated flows are evident uphill of the fence, they must be intercepted and conveyed to a sediment pond.

- It is important to check the uphill side of the fence for signs of the fence clogging and acting as a barrier to flow and then causing channelization of flows parallel to the fence. If this occurs, replace the fence or remove the trapped sediment.
- Sediment deposits shall either be removed when the deposit reaches approximately one-third the height of the silt fence, or a second silt fence shall be installed.
- If the filter fabric (geotextile) has deteriorated due to ultraviolet breakdown, it shall be replaced.

## **BMP C234: Vegetated Strip**

<b><i>Purpose</i></b>	Vegetated strips reduce the transport of coarse sediment from a construction site by providing a temporary physical barrier to sediment and reducing the runoff velocities of overland flow.
<b><i>Conditions of Use</i></b>	<p>☐ Vegetated strips may be used downslope of all disturbed areas.</p> <ul style="list-style-type: none"><li>• Vegetated strips are not intended to treat concentrated flows, nor are they intended to treat substantial amounts of overland flow. Any concentrated flows must be conveyed through the drainage system to a sediment pond. The only circumstance in which overland flow can be treated solely by a strip, rather than by a sediment pond, is when the following criteria are met (see Table 4.11):</li></ul>
<b><i>Design and Installation Specifications</i></b>	<p>☐ The vegetated strip shall consist of a minimum of a 25-foot wide continuous strip of dense vegetation with a permeable topsoil. Grass-covered, landscaped areas are generally not adequate because the volume of sediment overwhelms the grass. Ideally, vegetated strips shall consist of undisturbed native growth with a well-developed soil that allows for infiltration of runoff.</p> <ul style="list-style-type: none"><li>• The slope within the strip shall not exceed 4H:1V.</li><li>• The uphill boundary of the vegetated strip shall be delineated with clearing limits.</li></ul>
<b><i>Maintenance Standards</i></b>	<p>☐ Any areas damaged by erosion or construction activity shall be seeded immediately and protected by mulch.</p> <ul style="list-style-type: none"><li>• If more than 5 feet of the original vegetated strip width has had vegetation removed or is being eroded, sod must be installed.</li><li>• If there are indications that concentrated flows are traveling across the buffer, surface water controls must be installed to reduce the flows entering the buffer, or additional perimeter protection must be installed.</li></ul>

## BMP C235: Straw Wattles

### **Purpose**

Straw wattles are temporary erosion and sediment control barriers consisting of straw that is wrapped in biodegradable tubular plastic or similar encasing material. They reduce the velocity and can spread the flow of rill and sheet runoff, and can capture and retain sediment. Straw wattles are typically 8 to 10 inches in diameter and 25 to 30 feet in length. The wattles are placed in shallow trenches and staked along the contour of disturbed or newly constructed slopes. See Figure 4.22 for typical construction details.

### **Conditions of Use**

- Disturbed areas that require immediate erosion protection.
- Exposed soils during the period of short construction delays, or over winter months.
- On slopes requiring stabilization until permanent vegetation can be established.
- Straw wattles are effective for one to two seasons.
- If conditions are appropriate, wattles can be staked to the ground using willow cuttings for added revegetation.
- Rilling can occur beneath wattles if not properly entrenched and water can pass between wattles if not tightly abutted together.

### **Design Criteria**

- It is critical that wattles are installed perpendicular to the flow direction and parallel to the slope contour.
  - Narrow trenches should be dug across the slope on contour to a depth of 3 to 5 inches on clay soils and soils with gradual slopes. On loose soils, steep slopes, and areas with high rainfall, the trenches should be dug to a depth of 5 to 7 inches, or 1/2 to 2/3 of the thickness of the wattle.
  - Start building trenches and installing wattles from the base of the slope and work up. Excavated material should be spread evenly along the uphill slope and compacted using hand tamping or other methods.
  - Construct trenches at contour intervals of 3 to 30 feet apart depending on the steepness of the slope, soil type, and rainfall. The steeper the slope the closer together the trenches.
  - Install the wattles snugly into the trenches and abut tightly end to end. Do not overlap the ends.
  - Install stakes at each end of the wattle, and at 4-foot centers along entire length of wattle.
  - If required, install pilot holes for the stakes using a straight bar to drive holes through the wattle and into the soil.
  - At a minimum, wooden stakes should be approximately 3/4 x 3/4 x 24 inches. Willow cuttings or 3/8-inch rebar can also be used for stakes.
  - Stakes should be driven through the middle of the wattle, leaving 2 to 3 inches of the stake protruding above the wattle.

**Maintenance  
Standards**

☐ Wattles may require maintenance to ensure they are in contact with soil and thoroughly entrenched, especially after significant rainfall on steep sandy soils. |

☐ Inspect the slope after significant storms and repair any areas where wattles are not tightly abutted or water has scoured beneath the wattles. |



## **BMP C240: Sediment Trap**

**Purpose** A sediment trap is a small temporary ponding area with a gravel outlet used to collect and store sediment from sites cleared and/or graded during construction. Sediment traps, along with other perimeter controls, shall be installed before any land disturbance takes place in the drainage area.

**Conditions of Use** Prior to leaving a construction site, stormwater runoff must pass through a sediment pond or trap or other appropriate sediment removal best management practice. Non-engineered sediment traps may be used on-site prior to an engineered sediment trap or sediment pond to provide additional sediment removal capacity.

It is intended for use on sites where the tributary drainage area is less than 3 acres, with no unusual drainage features, and a projected build-out time of six months or less. The sediment trap is a temporary measure (with a design life of approximately 6 months) and shall be maintained until the site area is permanently protected against erosion by vegetation and/or structures.

Sediment traps and ponds are only effective in removing sediment down to about the medium silt size fraction. Runoff with sediment of finer grades (fine silt and clay) will pass through untreated, emphasizing the need to control erosion to the maximum extent first.

Whenever possible, sediment-laden water shall be discharged into onsite, relatively level, vegetated areas (see BMP C234 – Vegetated Strip). This is the only way to effectively remove fine particles from runoff unless chemical treatment or filtration is used. This can be particularly useful after initial treatment in a sediment trap or pond. The areas of release must be evaluated on a site-by-site basis in order to determine appropriate locations for and methods of releasing runoff. Vegetated wetlands shall not be used for this purpose. Frequently, it may be possible to pump water from the collection point at the downhill end of the site to an upslope vegetated area. Pumping shall only augment the treatment system, not replace it, because of the possibility of pump failure or runoff volume in excess of pump capacity.

All projects that are constructing permanent facilities for runoff quantity control should use the rough-graded or final-graded permanent facilities for traps and ponds. This includes combined facilities and infiltration facilities. When permanent facilities are used as temporary sedimentation facilities, the surface area requirement of a sediment trap or pond must be met. If the surface area requirements are larger than the surface area of the permanent facility, then the trap or pond shall be enlarged to comply with the surface area requirement. The permanent pond shall also be divided into two cells as required for sediment ponds.

Either a permanent control structure or the temporary control structure (described in BMP C241, Temporary Sediment Pond) can be used. If a permanent control structure is used, it may be advisable to partially restrict the lower orifice with gravel to increase residence time while still allowing dewatering of the pond. A shut-off valve may be added to the control structure to allow complete retention of stormwater in emergency situations. In this case, an emergency overflow weir must be added.

A skimmer may be used for the sediment trap outlet if approved by the Local Permitting Authority.

**Design and  
Installation  
Specifications**

☐ See Figures 4.23 and 4.24 for details.

☐ If permanent runoff control facilities are part of the project, they should be used for sediment retention.

- To determine the sediment trap geometry, first calculate the design surface area (SA) of the trap, measured at the invert of the weir. Use the following equation:

$$SA = FS(Q_2/V_S)$$

where

$Q_2$  = Design inflow based on the peak discharge from the developed 2-year runoff event from the contributing drainage area as computed in the hydrologic analysis. The 10-year peak flow shall be used if the project size, expected timing and duration of construction, or downstream conditions warrant a higher level of protection. If no hydrologic analysis is required, the Rational Method may be used.

$V_S$  = The settling velocity of the soil particle of interest. The 0.02 mm (medium silt) particle with an assumed density of 2.65 g/cm<sup>3</sup> has been selected as the particle of interest and has a settling velocity ( $V_S$ ) of 0.00096 ft/sec.

$FS$  = A safety factor of 2 to account for non-ideal settling.

Therefore, the equation for computing surface area becomes:

$$SA = 2 \times Q_2 / 0.00096 \text{ or}$$

2080 square feet per cfs of inflow

Note: Even if permanent facilities are used, they must still have a surface area that is at least as large as that derived from the above formula. If they do not, the pond must be enlarged.

- To aid in determining sediment depth, all sediment traps shall have a staff gauge with a prominent mark 1-foot above the bottom of the trap.
- Sediment traps may not be feasible on utility projects due to the limited work space or the short-term nature of the work. Portable tanks may be used in place of sediment traps for utility projects.

| **Maintenance  
Standards**

- ☐ Sediment shall be removed from the trap when it reaches 1-foot in depth.
- Any damage to the pond embankments or slopes shall be repaired.

## **BMP C241: Temporary Sediment Pond**

<b>Purpose</b>	Sediment ponds remove sediment from runoff originating from disturbed areas of the site. Sediment ponds are typically designed to remove sediment no smaller than medium silt (0.02 mm). Consequently, they usually reduce turbidity only slightly.
<b>Conditions of Use</b>	<p>Prior to leaving a construction site, stormwater runoff must pass through a sediment pond or other appropriate sediment removal best management practice.</p> <p>A sediment pond shall be used where the contributing drainage area is 3 acres or more. Ponds must be used in conjunction with erosion control practices to reduce the amount of sediment flowing into the basin.</p>
<b>Design and Installation Specifications</b>	<p>☐ Sediment basins must be installed only on sites where failure of the structure would not result in loss of life, damage to homes or buildings, or interruption of use or service of public roads or utilities. Also, sediment traps and ponds are attractive to children and can be very dangerous. Compliance with local ordinances regarding health and safety must be addressed. If fencing of the pond is required, the type of fence and its location shall be shown on the ESC plan.</p> <ul style="list-style-type: none"><li>• Structures having a maximum storage capacity at the top of the dam of 10 acre-ft (435,600 ft<sup>3</sup>) or more are subject to the Washington Dam Safety Regulations (Chapter 173-175 WAC).</li><li>• See Figures 4.25, 4.26, and 4.27 for details.</li><li>• If permanent runoff control facilities are part of the project, they should be used for sediment retention. The surface area requirements of the sediment basin must be met. This may require enlarging the permanent basin to comply with the surface area requirements. If a permanent control structure is used, it may be advisable to partially restrict the lower orifice with gravel to increase residence time while still allowing dewatering of the basin.</li><li>• Use of infiltration facilities for sedimentation basins during construction tends to clog the soils and reduce their capacity to infiltrate. If infiltration facilities are to be used, the sides and bottom of the facility must only be rough excavated to a minimum of 2 feet above final grade. Final grading of the infiltration facility shall occur only when all contributing drainage areas are fully stabilized. The infiltration pretreatment facility should be fully constructed and used with the sedimentation basin to help prevent clogging.</li><li>• Determining Pond Geometry Obtain the discharge from the hydrologic calculations of the peak flow for the 2-year runoff event (<math>Q_2</math>). The 10-year peak flow shall be used if the project size, expected timing and duration of construction, or downstream conditions warrant a higher level of protection. If no hydrologic analysis is required, the Rational Method may be used.</li></ul>

Determine the required surface area at the top of the riser pipe with the equation:

$$SA = 2 \times Q_2 / 0.00096 \quad \text{or} \quad 2080 \text{ square feet per cfs of inflow}$$

See BMP C240 for more information on the derivation of the surface area calculation.

The basic geometry of the pond can now be determined using the following design criteria:

- Required surface area SA (from Step 2 above) at top of riser.
- Minimum 3.5-foot depth from top of riser to bottom of pond.
- Maximum 3:1 interior side slopes and maximum 2:1 exterior slopes. The interior slopes can be increased to a maximum of 2:1 if fencing is provided at or above the maximum water surface.
- One foot of freeboard between the top of the riser and the crest of the emergency spillway.
- Flat bottom.
- Minimum 1-foot deep spillway.
- Length-to-width ratio between 3:1 and 6:1.
- Sizing of Discharge Mechanisms.

The outlet for the basin consists of a combination of principal and emergency spillways. These outlets must pass the peak runoff expected from the contributing drainage area for a 100-year storm. If, due to site conditions and basin geometry, a separate emergency spillway is not feasible, the principal spillway must pass the entire peak runoff expected from the 100-year storm. However, an attempt to provide a separate emergency spillway should always be made. The runoff calculations should be based on the site conditions during construction. The flow through the dewatering orifice cannot be utilized when calculating the 100-year storm elevation because of its potential to become clogged; therefore, available spillway storage must begin at the principal spillway riser crest.

The principal spillway designed by the procedures contained in this standard will result in some reduction in the peak rate of runoff. However, the riser outlet design will not adequately control the basin discharge to the predevelopment discharge limitations as stated in Minimum Requirement #57: [Stormwater Detention Flow Control](#). However, if the basin for a permanent stormwater detention pond is used for a temporary sedimentation basin, the control structure for the permanent pond can be used to maintain predevelopment discharge limitations. The size of the basin, the expected life of the construction project, the anticipated downstream effects and the anticipated weather conditions during construction, should be considered to determine the need of additional discharge control. See Figure 4.28 for riser inflow curves.

**Principal Spillway:** Determine the required diameter for the principal spillway (riser pipe). The diameter shall be the minimum necessary to pass the pre-developed 10-year peak flow ( $Q_{10}$ ). Use Figure 4.28 to determine this diameter ( $h = 1$ -foot). *Note: A permanent control structure may be used instead of a temporary riser.*

**Emergency Overflow Spillway:** Determine the required size and design of the emergency overflow spillway for the developed 100-year peak flow using the method contained in Volume III.

**Dewatering Orifice:** Determine the size of the dewatering orifice(s) (minimum 1-inch diameter) using a modified version of the discharge equation for a vertical orifice and a basic equation for the area of a circular orifice. Determine the required area of the orifice with the following equation:

$$A_o = \frac{A_s (2h)^{0.5}}{0.6 \times 3600 T g^{0.5}}$$

where  $A_o$  = orifice area (square feet)  
 $A_s$  = pond surface area (square feet)  
 $h$  = head of water above orifice (height of riser in feet)  
 $T$  = dewatering time (24 hours)  
 $g$  = acceleration of gravity (32.2 feet/second<sup>2</sup>)

Convert the required surface area to the required diameter  $D$  of the orifice:

$$D = 24 \times \sqrt{\frac{A_o}{\pi}} = 13.54 \times \sqrt{A_o}$$

The vertical, perforated tubing connected to the dewatering orifice must be at least 2 inches larger in diameter than the orifice to improve flow characteristics. The size and number of perforations in the tubing should be large enough so that the tubing does not restrict flow. The orifice should control the flow rate.

- **Additional Design Specifications**

The **pond shall be divided** into two roughly equal volume cells by a permeable divider that will reduce turbulence while allowing movement of water between cells. The divider shall be at least one-half the height of the riser and a minimum of one foot below the top of the riser. Wire-backed, 2- to 3-foot high, extra strength filter fabric supported by treated 4"x4"s can be used as a divider. Alternatively, staked straw bales wrapped with filter fabric (geotextile) may be used. If the pond is more than 6 feet deep, a different mechanism must be proposed. A riprap embankment is one acceptable method of separation for deeper ponds. Other designs that satisfy the intent of this provision are allowed as long as the divider is permeable, structurally sound, and designed to prevent erosion under or around the barrier.

To aid in determining sediment depth, **one-foot intervals** shall be prominently marked on the riser.

If an **embankment** of more than 6 feet is proposed, the pond must comply with the criteria contained in Volume III regarding dam safety for detention BMPs.

- The most common structural failure of sedimentation basins is caused by piping. Piping refers to two phenomena: (1) water seeping through fine-grained soil, eroding the soil grain by grain and forming pipes or tunnels; and, (2) water under pressure flowing upward through a granular soil with a head of sufficient magnitude to cause soil grains to lose contact and capability for support.

The most critical construction sequences to prevent piping will be:

1. Tight connections between riser and barrel and other pipe connections.
2. Adequate anchoring of riser.
3. Proper soil compaction of the embankment and riser footing.
4. Proper construction of anti-seep devices.

Sediment shall be removed from the pond when it reaches 1-foot in depth.

Any damage to the pond embankments or slopes shall be repaired.

**Maintenance  
Standards**

## **BMP C250: Construction Stormwater Chemical Treatment**

**Purpose** Turbidity is difficult to control once fine particles are suspended in stormwater runoff from a construction site. Sedimentation ponds are effective at removing larger particulate matter by gravity settling, but are ineffective at removing smaller particulates such as clay and fine silt. Sediment ponds are typically designed to remove sediment no smaller than medium silt (0.02 mm). Chemical treatment may be used to reduce the turbidity of stormwater runoff.

**Conditions of Use** Chemical treatment can reliably provide exceptional reductions of turbidity and associated pollutants. Very high turbidities can be reduced to levels comparable to what is found in streams during dry weather. Traditional BMPs used to control soil erosion and sediment loss from sites under development may not be adequate to ensure compliance with the water quality standard for turbidity in the receiving water. Chemical treatment may be required to protect streams from the impact of turbid stormwater discharges, especially when construction is to proceed through the wet season.

**Formal written approval from Ecology and the Local Permitting Authority is required for the use of chemical treatment regardless of site size. The intention to use Chemical Treatment shall be indicated on the Notice of Intent for coverage under the General Construction Permit. Chemical treatment systems should be designed as part of the Construction SWPPP, not after the fact. Chemical treatment may be used to correct problem sites in limited circumstances with formal written approval from Ecology and the Local Permitting Authority.**

The SEPA review authority must be notified at the application phase of the project review (or the time that the SEPA determination on the project is performed) that chemical treatment is proposed. If it is added after this stage, an addendum will be necessary and may result in project approval delay.

### **Design and Installation Specifications**

See Appendix II-B for background information on chemical treatment.

**Criteria for Chemical Treatment Product Use:** Chemically treated stormwater discharged from construction sites must be nontoxic to aquatic organisms. The following protocol shall be used to evaluate chemicals proposed for stormwater treatment at construction sites. Authorization to use a chemical in the field based on this protocol does not relieve the applicant from responsibility for meeting all discharge and receiving water criteria applicable to a site.

- Treatment chemicals must be approved by EPA for potable water use.
- Petroleum-based polymers are prohibited.
- Prior to authorization for field use, jar tests shall be conducted to demonstrate that turbidity reduction necessary to meet the receiving water criteria can be achieved. Test conditions, including but not



limited to raw water quality and jar test procedures, should be indicative of field conditions. Although these small-scale tests cannot be expected to reproduce performance under field conditions, they are indicative of treatment capability.

- Prior to authorization for field use, the chemically treated stormwater shall be tested for aquatic toxicity. Applicable procedures defined in Chapter 173-205 WAC, Whole Effluent Toxicity Testing and Limits, shall be used. Testing shall use stormwater from the construction site at which the treatment chemical is proposed for use or a water solution using soil from the proposed site.
- The proposed maximum dosage shall be at least a factor of five lower than the no observed effects concentration (NOEC).
- The approval of a proposed treatment chemical shall be conditional, subject to full-scale bioassay monitoring of treated stormwater at the construction site where the proposed treatment chemical is to be used.
- Treatment chemicals that have already passed the above testing protocol do not need to be reevaluated. Contact the Department of Ecology Regional Office for a list of treatment chemicals that have been evaluated and are currently approved for use.

**Treatment System Design Considerations:** The design and operation of a chemical treatment system should take into consideration the factors that determine optimum, cost-effective performance. It may not be possible to fully incorporate all of the classic concepts into the design because of practical limitations at construction sites. Nonetheless, it is important to recognize the following:

- The right chemical must be used at the right dosage. A dosage that is either too low or too high will not produce the lowest turbidity. There is an optimum dosage rate. This is a situation where the adage “adding more is always better” is not the case.
- The coagulant must be mixed rapidly into the water to insure proper dispersion.
- A flocculation step is important to increase the rate of settling, to produce the lowest turbidity, and to keep the dosage rate as low as possible.
- Too little energy input into the water during the flocculation phase results in flocs that are too small and/or insufficiently dense. Too much energy can rapidly destroy floc as it is formed.
- Since the volume of the basin is a determinant in the amount of energy per unit volume, the size of the energy input system can be too small relative to the volume of the basin.
- Care must be taken in the design of the withdrawal system to minimize outflow velocities and to prevent floc discharge. The discharge should be directed through a physical filter such as a vegetated swale that would catch any unintended floc discharge.

**Treatment System Design:** Chemical treatment systems shall be designed as batch treatment systems using either ponds or portable trailer-mounted tanks. Flow-through continuous treatment systems are not allowed at this time.

A chemical treatment system consists of the stormwater collection system (either temporary diversion or the permanent site drainage system), a storage pond, pumps, a chemical feed system, treatment cells, and interconnecting piping.

The treatment system shall use a minimum of two lined treatment cells. Multiple treatment cells allow for clarification of treated water while other cells are being filled or emptied. Treatment cells may be ponds or tanks. Ponds with constructed earthen embankments greater than six feet high require special engineering analyses. Portable tanks may also be suitable for some sites.

The following equipment should be located in an operations shed:

- The chemical injector;
- Secondary containment for acid, caustic, buffering compound, and treatment chemical;
- Emergency shower and eyewash, and
- Monitoring equipment which consists of a pH meter and a turbidimeter.

**Sizing Criteria:** The combination of the storage pond or other holding area and treatment capacity should be large enough to treat stormwater during multiple day storm events. It is recommended that at a minimum the storage pond or other holding area should be sized to hold 1.5 times the runoff volume of the 10-year, 24-hour storm event. Bypass should be provided around the chemical treatment system to accommodate extreme storm events. Runoff volume shall be calculated using the methods presented in Volume 3, Chapter 2. If no hydrologic analysis is required for the site, the Rational Method may be used.

Primary settling should be encouraged in the storage pond. A forebay with access for maintenance may be beneficial.

There are two opposing considerations in sizing the treatment cells. A larger cell is able to treat a larger volume of water each time a batch is processed. However, the larger the cell the longer the time required to empty the cell. A larger cell may also be less effective at flocculation and therefore require a longer settling time. The simplest approach to sizing the treatment cell is to multiply the allowable discharge flow rate times the desired drawdown time. A 4-hour drawdown time allows one batch per cell per 8-hour work period, given 1 hour of flocculation followed by two hours of settling.

The permissible discharge rate governed by potential downstream effect can be used to calculate the recommended size of the treatment cells. The following discharge flow rate limits shall apply:

- If the discharge is directly or indirectly to a stream, the discharge flow rate shall not exceed 50 percent of the peak flow rate of the 2-year, 24-hour event for all storm events up to the 10-year, 24-hour event.
- If discharge is occurring during a storm event equal to or greater than the 10-year, 24-hour event, the allowable discharge rate is the peak flow rate of the 10-year, 24-hour event.
- Discharge to a stream should not increase the stream flow rate by more than 10 percent.
- If the discharge is directly to a lake, a major receiving water listed in Appendix C of Volume I, or to an infiltration system, there is no discharge flow limit.
- If the discharge is to a municipal storm drainage system, the allowable discharge rate may be limited by the capacity of the public system. It may be necessary to clean the municipal storm drainage system prior to the start of the discharge to prevent scouring solids from the drainage system.
- Runoff rates shall be calculated using the methods presented in Volume 3, Chapter 2 for the predeveloped condition. If no hydrologic analysis is required for the site, the Rational Method may be used.

**Maintenance Standards**

**Monitoring:** The following monitoring shall be conducted. Test results shall be recorded on a daily log kept on site:

Operational Monitoring

- pH, conductivity (as a surrogate for alkalinity), turbidity and temperature of the untreated stormwater
- Total volume treated and discharged
- Discharge time and flow rate
- Type and amount of chemical used for pH adjustment
- Amount of polymer used for treatment
- Settling time

Compliance Monitoring

- pH and turbidity of the treated stormwater
- pH and turbidity of the receiving water

Biomonitoring

Treated stormwater shall be tested for acute (lethal) toxicity. Bioassays shall be conducted by a laboratory accredited by Ecology, unless otherwise approved by Ecology. **The performance standard for acute toxicity is no statistically significant difference in survival between the control and 100 percent chemically treated stormwater.**

Acute toxicity tests shall be conducted with the following species and protocols:

- Fathead minnow, *Pimephales promelas* (96 hour static-renewal test, method: EPA/600/4-90/027F). Rainbow trout, *Oncorhynchus mykiss* (96 hour static-renewal test, method: EPA/600/4-90/027F) may be used as a substitute for fathead minnow.
- Daphnid, *Ceriodaphnia dubia*, *Daphnia pulex*, or *Daphnia magna* (48 hour static test, method: EPA/600/4-90/027F).

All toxicity tests shall meet quality assurance criteria and test conditions in the most recent versions of the EPA test method and Ecology Publication # WQ-R-95-80, Laboratory Guidance and Whole Effluent Toxicity Test Review Criteria.

Bioassays shall be performed on the first five batches and on every tenth batch thereafter, or as otherwise approved by Ecology. Failure to meet the performance standard shall be immediately reported to Ecology.

**Discharge Compliance: Prior to discharge, each batch of treated stormwater must be sampled and tested for compliance with pH and turbidity limits.** These limits may be established by the water quality standards or a site-specific discharge permit. Sampling and testing for other pollutants may also be necessary at some sites. Turbidity must be within 5 NTUs of the background turbidity. Background is measured in the receiving water, upstream from the treatment process discharge point. pH must be within the range of 6.5 to 8.5 standard units and not cause a change in the pH of the receiving water of more than 0.2 standard units. It is often possible to discharge treated stormwater that has a lower turbidity than the receiving water and that matches the pH.

Treated stormwater samples and measurements shall be taken from the discharge pipe or another location representative of the nature of the treated stormwater discharge. Samples used for determining compliance with the water quality standards in the receiving water shall not be taken from the treatment pond prior to decanting. Compliance with the water quality standards is determined in the receiving water.

**Operator Training:** Each contractor who intends to use chemical treatment shall be trained by an experienced contractor on an active site for at least 40 hours.

**Standard BMPs:** Surface stabilization BMPs should be implemented on site to prevent significant erosion. All sites shall use a truck wheel wash to prevent tracking of sediment off site.

**Sediment Removal And Disposal:**

- Sediment shall be removed from the storage or treatment cells as necessary. Typically, sediment removal is required at least once during a wet season and at the decommissioning of the cells. Sediment remaining in the cells between batches may enhance the settling process and reduce the required chemical dosage.
- Sediment may be incorporated into the site away from drainages.

## **BMP C251: Construction Stormwater Filtration**

**Purpose** Filtration removes sediment from runoff originating from disturbed areas of the site.

**Conditions of Use** Traditional BMPs used to control soil erosion and sediment loss from sites under development may not be adequate to ensure compliance with the water quality standard for turbidity in the receiving water. Filtration may be used in conjunction with gravity settling to remove sediment as small as fine silt (0.5  $\mu\text{m}$ ). The reduction in turbidity will be dependent on the particle size distribution of the sediment in the stormwater. In some circumstances, sedimentation and filtration may achieve compliance with the water quality standard for turbidity.

Unlike chemical treatment, the use of construction stormwater filtration does not require approval from Ecology.

Filtration may also be used in conjunction with polymer treatment in a portable system to assure capture of the flocculated solids.

### **Design and Installation Specifications**

#### **Background Information**

Filtration with sand media has been used for over a century to treat water and wastewater. The use of sand filtration for treatment of stormwater has developed recently, generally to treat runoff from streets, parking lots, and residential areas. The application of filtration to construction stormwater treatment is currently under development.

Two types of filtration systems may be applied to construction stormwater treatment: rapid and slow. Rapid sand filters are the typical system used for water and wastewater treatment. They can achieve relatively high hydraulic flow rates, on the order of 2 to 20 gpm/sf, because they have automatic backwash systems to remove accumulated solids. In contrast, slow sand filters have very low hydraulic rates, on the order of 0.02 gpm/sf, because they do not have backwash systems. To date, slow sand filtration has generally been used to treat stormwater. Slow sand filtration is mechanically simple in comparison to rapid sand filtration but requires a much larger filter area.

**Filtration Equipment.** Sand media filters are available with automatic backwashing features that can filter to 50  $\mu\text{m}$  particle size. Screen or bag filters can filter down to 5  $\mu\text{m}$ . Fiber wound filters can remove particles down to 0.5  $\mu\text{m}$ . Filters should be sequenced from the largest to the smallest pore opening. Sediment removal efficiency will be related to particle size distribution in the stormwater.

**Treatment Process Description.** Stormwater is collected at interception point(s) on the site and is diverted to a sediment pond or tank for removal of large sediment and storage of the stormwater before it is treated by the filtration system. The stormwater is pumped from the trap, pond, or tank through the filtration system in a rapid sand filtration system. Slow sand filtration systems are designed as flow through systems using gravity.

**Maintenance  
Standards**

If large volumes of concrete are being poured, pH adjustment may be necessary.

⚠ Rapid sand filters typically have automatic backwash systems that are triggered by a pre-set pressure drop across the filter. If the backwash water volume is not large or substantially more turbid than the stormwater stored in the holding pond or tank, backwash return to the pond or tank may be appropriate. However, land application or another means of treatment and disposal may be necessary.

- Screen, bag, and fiber filters must be cleaned and/or replaced when they become clogged.
- Sediment shall be removed from the storage and/or treatment ponds as necessary. Typically, sediment removal is required once or twice during a wet season and at the decommissioning of the ponds.

<b>Name</b>	<b>Action</b>	<b>Date</b>
<b>Anne Spangler</b>	<b>First Revisions</b>	<b>3/12/2002</b>

<b>Table 4.1 Temporary Erosion Control Seed Mix</b>			
	<b>% Weight</b>	<b>% Purity</b>	<b>% Germination</b>
Chewings or annual blue grass <i>Festuca rubra var. commutata</i> or <i>Poa anna</i>	40	98	90
Perennial rye - <i>Lolium perenne</i>	50	98	90
Redtop or colonial bentgrass <i>Agrostis alba</i> or <i>Agrostis tenuis</i>	5	92	85
White dutch clover <i>Trifolium repens</i>	5	98	90

<b>Table 4.2 Landscaping Seed Mix</b>			
	<b>% Weight</b>	<b>% Purity</b>	<b>% Germination</b>
Perennial rye blend <i>Lolium perenne</i>	70	98	90
Chewings and red fescue blend <i>Festuca rubra var. commutata</i> or <i>Festuca rubra</i>	30	98	90

<b>Table 4.3 Low-Growing Turf Seed Mix</b>			
	<b>% Weight</b>	<b>% Purity</b>	<b>% Germination</b>
Dwarf tall fescue (several varieties) <i>Festuca arundinacea var.</i>	45	98	90
Dwarf perennial rye (Barclay) <i>Lolium perenne var. barclay</i>	30	98	90
Red fescue <i>Festuca rubra</i>	20	98	90
Colonial bentgrass <i>Agrostis tenuis</i>	5	98	90

<b>Table 4.4 Bioswale Seed Mix*</b>			
	<b>% Weight</b>	<b>% Purity</b>	<b>% Germination</b>
Tall or meadow fescue <i>Festuca arundinacea</i> or <i>Festuca elatior</i>	75-80	98	90
Seaside/Creeping bentgrass <i>Agrostis palustris</i>	10-15	92	85

Redtop bentgrass <i>Agrostis alba</i> or <i>Agrostis gigantea</i>	5-10	90	80
--	------	----	----

\* Modified Briargreen, Inc. Hydroseeding Guide Wetlands Seed Mix



<b>Table 4.5 Wet Area Seed Mix*</b>			
	<b>% Weight</b>	<b>% Purity</b>	<b>% Germination</b>
Tall or meadow fescue <i>Festuca arundinacea</i> or <i>Festuca elatior</i>	60-70	98	90
Seaside/Creeping bentgrass <i>Agrostis palustris</i>	10-15	98	85
Meadow foxtail <i>Alepocurus pratensis</i>	10-15	90	80
Alsike clover <i>Trifolium hybridum</i>	1-6	98	90
Redtop bentgrass <i>Agrostis alba</i>	1-6	92	85

\* Modified Briargreen, Inc. Hydroseeding Guide Wetlands Seed Mix

<b>Table 4.6 Meadow Seed Mix</b>			
	<b>% Weight</b>	<b>% Purity</b>	<b>% Germination</b>
Redtop or Oregon bentgrass <i>Agrostis alba</i> or <i>Agrostis oregonensis</i>	20	92	85
Red fescue <i>Festuca rubra</i>	70	98	90
White dutch clover <i>Trifolium repens</i>	10	98	90



**Table 4.7  
Mulch Standards and Guidelines**

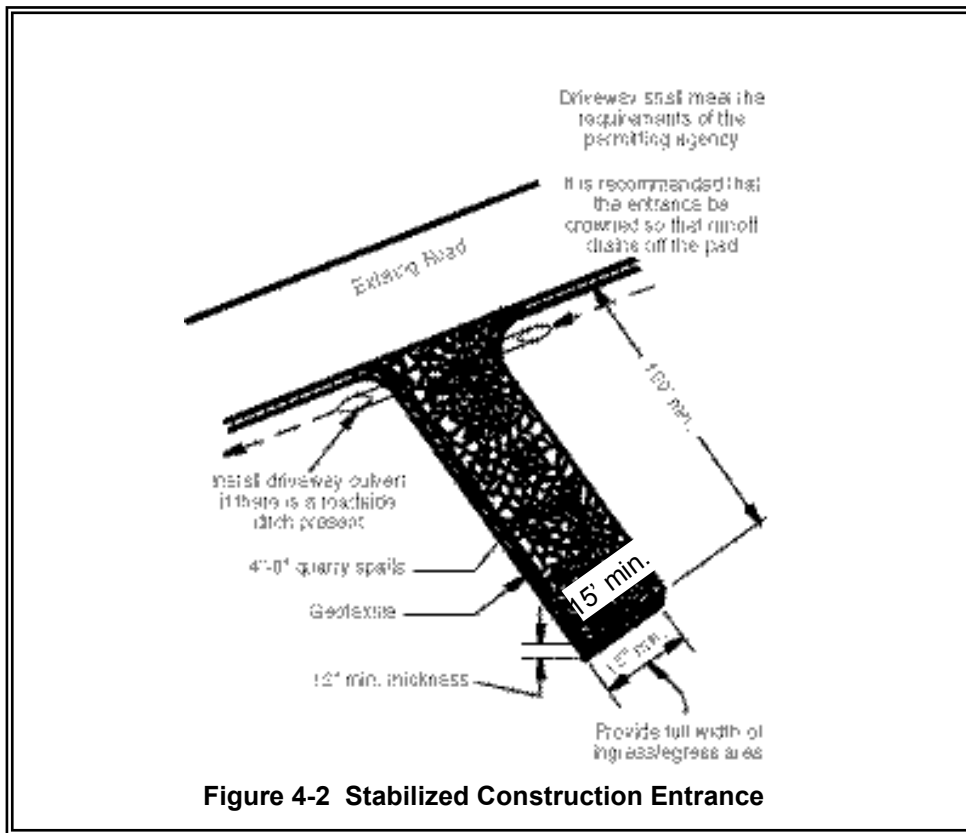
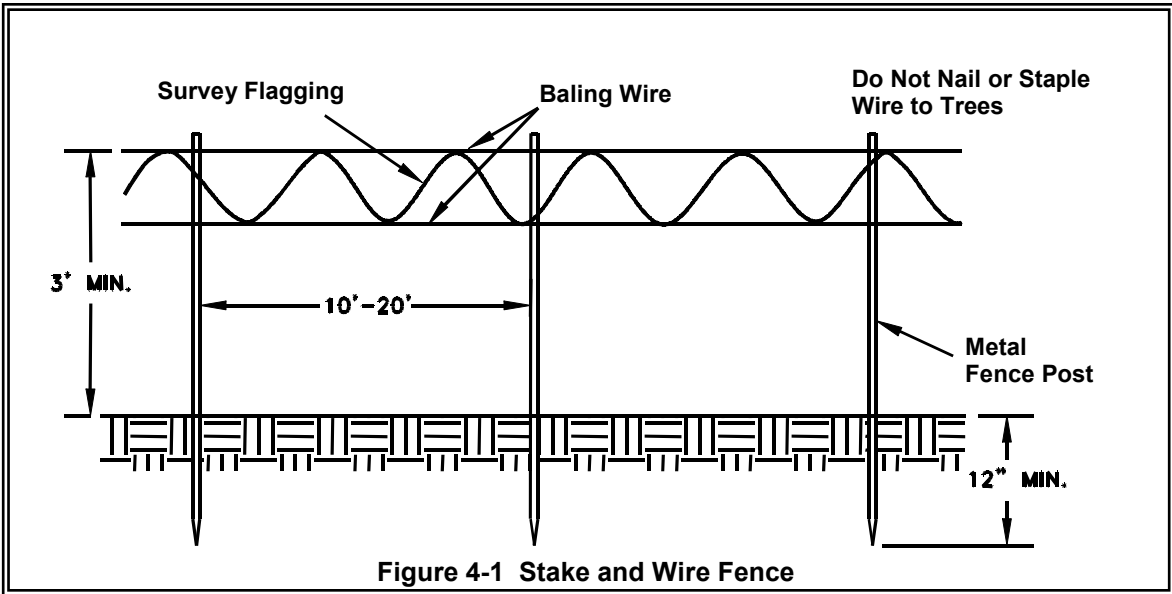
<b>Mulch Material</b>	<b>Quality Standards</b>	<b>Application Rates</b>	<b>Remarks</b>
Straw	Air-dried; free from undesirable seed and coarse material.	2"-3" thick; 5 bales per 1000 sf or 2-3 tons per acre	Cost-effective protection when applied with adequate thickness. Hand-application generally requires greater thickness than blown straw. The thickness of straw may be reduced by half when used in conjunction with seeding. In windy areas straw must be held in place by crimping, using a tackifier, or covering with netting. Blown straw always has to be held in place with a tackifier as even light winds will blow it away. Straw, however, has several deficiencies that should be considered when selecting mulch materials. It often introduces and/or encourages the propagation of weed species and it has no significant long-term benefits. Straw should be used only if mulches with long-term benefits are unavailable locally. It should also not be used within the ordinary high-water elevation of surface waters (due to flotation).
Hydromulch	No growth inhibiting factors.	Approx. 25-30 lbs per 1000 sf or 1500 - 2000 lbs per acre	Shall be applied with hydromulcher. Shall not be used without seed and tackifier unless the application rate is at least doubled. Fibers longer than about ¾-1 inch clog hydromulch equipment. Fibers should be kept to less than ¾ inch.
Composted Mulch and Compost	No visible water or dust during handling. Must be purchased from supplier with Solid Waste Handling Permit (unless exempt).	2" thick min.; approx. 100 tons per acre (approx. 800 lbs per yard)	More effective control can be obtained by increasing thickness to 3". Excellent mulch for protecting final grades until landscaping because it can be directly seeded or tilled into soil as an amendment. Composted mulch has a coarser size gradation than compost. It is more stable and practical to use in wet areas and during rainy weather conditions.
Chipped Site Vegetation	Average size shall be several inches. Gradations from fines to 6 inches in length for texture, variation, and interlocking properties.	2" minimum thickness	This is a cost-effective way to dispose of debris from clearing and grubbing, and it eliminates the problems associated with burning. Generally, it should not be used on slopes above approx. 10% because of its tendency to be transported by runoff. It is not recommended within 200 feet of surface waters. If seeding is expected shortly after mulch, the decomposition of the chipped vegetation may tie up nutrients important to grass establishment.
Wood-based Mulch	No visible water or dust during handling. Must be purchased from a supplier with a Solid Waste Handling Permit or one exempt from solid waste regulations.	2" thick; approx. 100 tons per acre (approx. 800 lbs. per cubic yard)	This material is often called "hog or hogged fuel." It is usable as a material for Stabilized Construction Entrances (BMP C105) and as a mulch. The use of mulch ultimately improves the organic matter in the soil. Special caution is advised regarding the source and composition of wood-based mulches. Its preparation typically does not provide any weed seed control, so evidence of residual vegetation in its composition or known inclusion of weed plants or seeds should be monitored and prevented (or minimized).

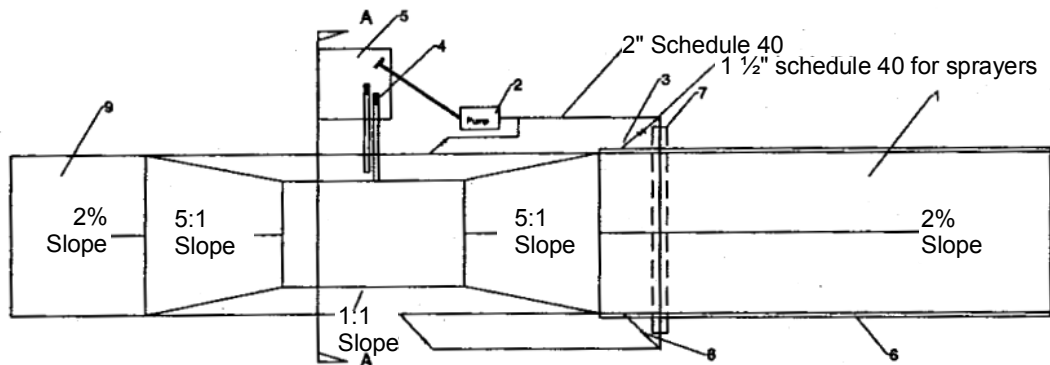
Table 4.8 PAM and Water Application Rates		
Disturbed Area (ac)	PAM (lbs)	Water (gal)
0.50	0.25	500
1.00	0.50	1,000
1.50	0.75	1,500
2.00	1.00	2,000
2.50	1.25	2,500
3.00	1.50	3,000
3.50	1.75	3,500
4.00	2.00	4,000
4.50	2.25	4,500
5.00	2.50	5,000

Table 4.9 <u>Storm Drain</u> Inlet Protection			
Type of Inlet Protection	Emergency Overflow	Applicable for Paved/ Earthen Surfaces	Conditions of Use
<b>Drop Inlet Protection</b>			
Excavated drop inlet protection	Yes, temporary flooding will occur	Earthen	Applicable for heavy flows. Easy to maintain. Large area Requirement: 30' X 30'/acre
Block and gravel drop inlet protection	Yes	Paved or Earthen	Applicable for heavy concentrated flows. Will not pond.
Gravel and wire drop inlet protection	No		Applicable for heavy concentrated flows. Will pond. Can withstand traffic.
Catch basin filters	Yes	Paved or Earthen	Frequent maintenance required.
<b>Curb Inlet Protection</b>			
Curb inlet protection with a wooden weir	Small capacity overflow	Paved	Used for sturdy, more compact installation.
Block and gravel curb inlet protection	Yes	Paved	Sturdy, but limited filtration.
<b>Culvert Inlet Protection</b>			
Culvert inlet sediment trap			18 month expected life.

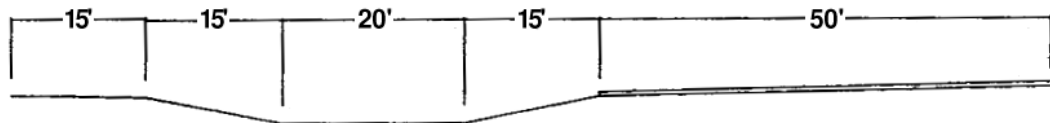
Polymeric Mesh AOS (ASTM D4751)	0.60 mm maximum for slit film wovens (#30 sieve). 0.30 mm maximum for all other geotextile types (#50 sieve). 0.15 mm minimum for all fabric types (#100 sieve).
Water Permittivity (ASTM D4491)	0.02 sec <sup>-1</sup> minimum
Grab Tensile Strength (ASTM D4632)	180 lbs. Minimum for extra strength fabric. 100 lbs minimum for standard strength fabric.
Grab Tensile Strength (ASTM D4632)	30% maximum
Ultraviolet Resistance (ASTM D4355)	70% minimum

Average Slop	Slope Percent	Flowpath Length
1.5H:1V or less	67% or less	100 feet
2H:1V or less	50% or less	115 feet
4H:1V or less	25% or less	150 feet
6H:1V or less	16.7% or less	200 feet
10H:1V or less	10% or less	250 feet

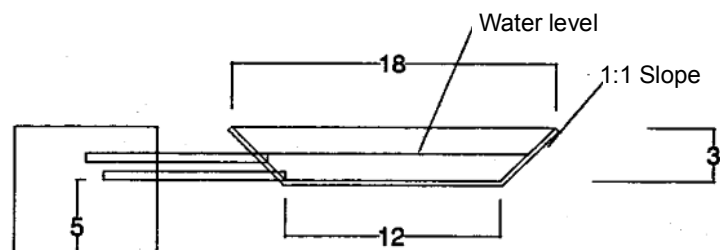




**Wheel Wash Plan**



**Elevation View**

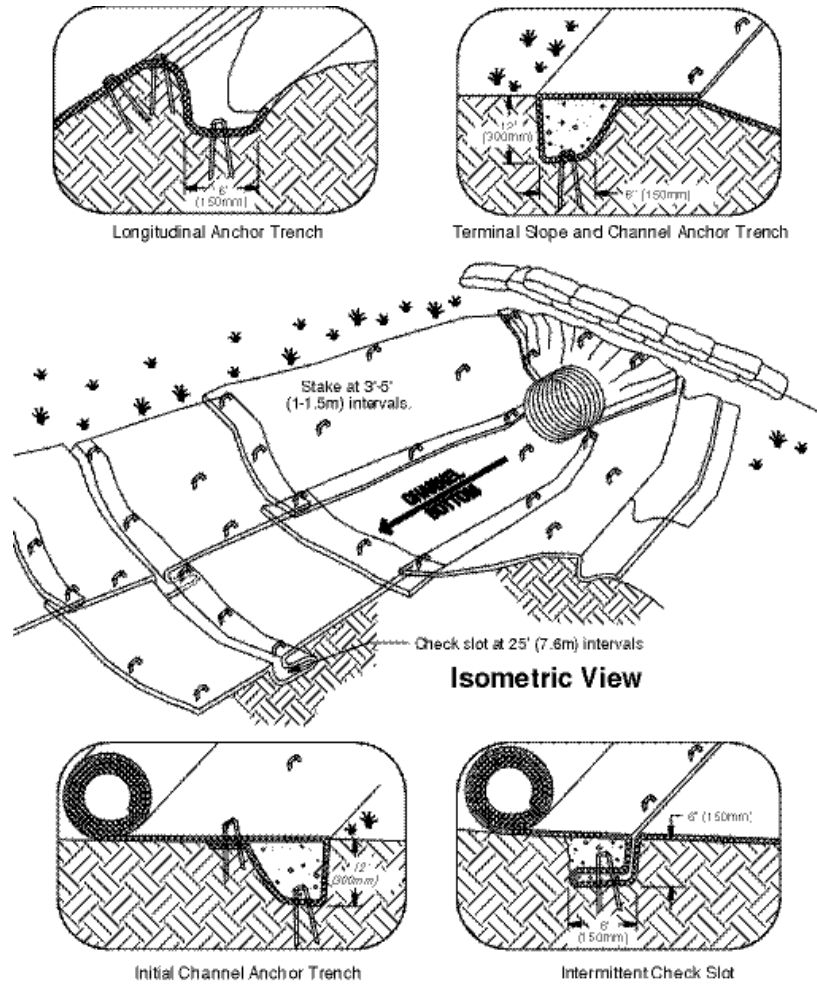


**Section A-A  
N.I.S.**

**Notes:**

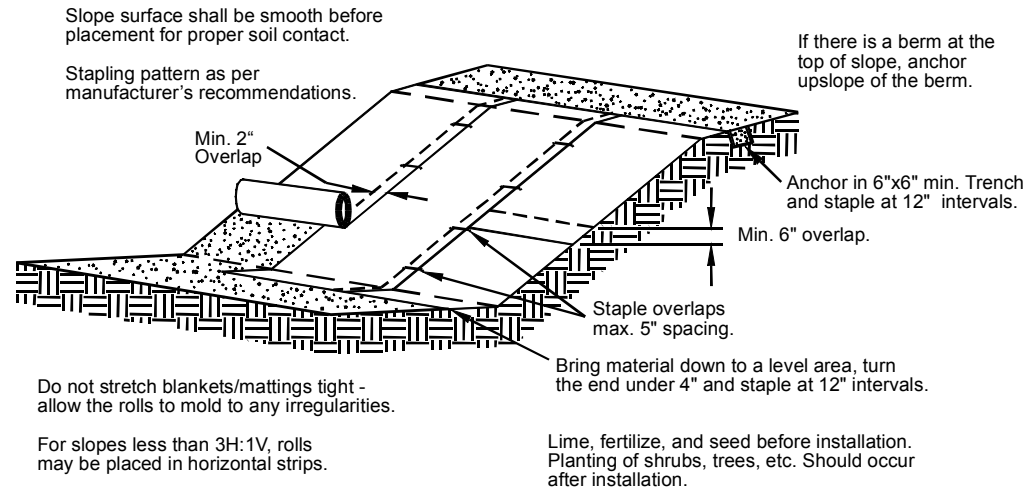
1. Asphalt construction entrance 6 in. asphalt treated base (ATB).
2. 3-inch trash pump with floats on the suction hose.
3. Midpoint spray nozzles, if needed.
4. 6-inch sewer pipe with butterfly valves. Bottom one is a drain. Locate top pipe's invert 1 foot above bottom of wheel wash.
5. 8 foot x 8 foot sump with 5 feet of catch. Build so can be cleaned with trackhoe.
6. Asphalt curb on the low road side to direct water back to pond.
7. 6-inch sleeve under road.
8. Ball valves.
9. 15 foot. ATB apron to protect ground from splashing water.

**Figure 4-3 Wheel Wash**

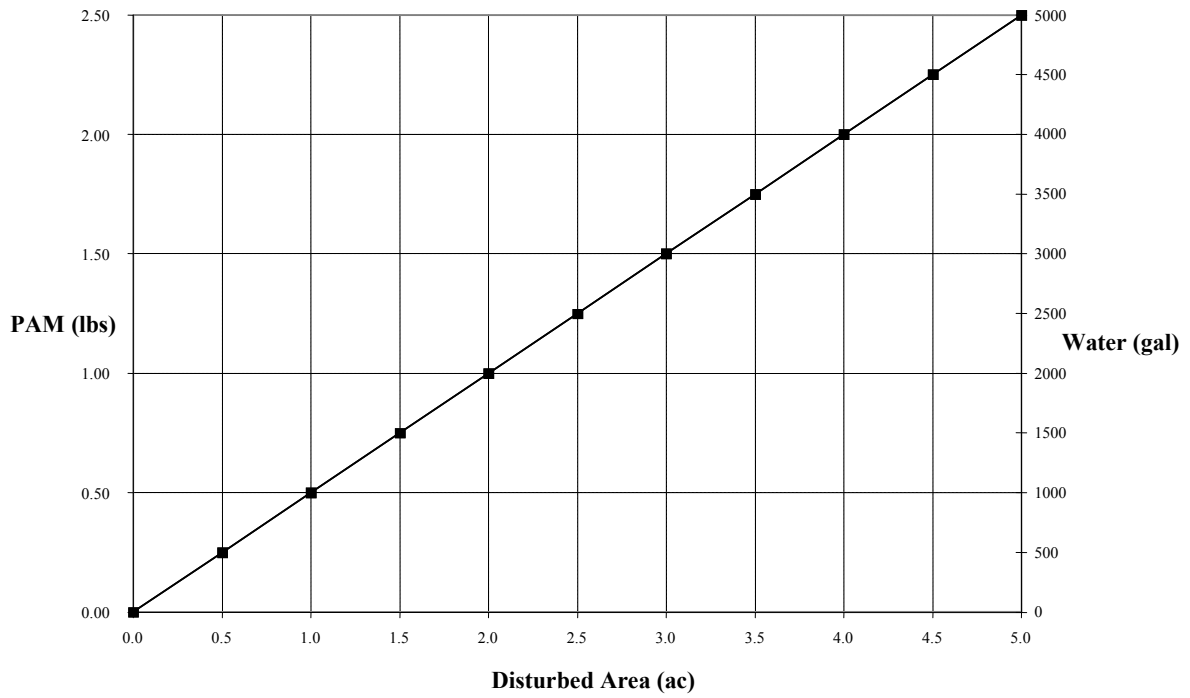


- NOTES:
1. Check slots to be constructed per manufacturers specifications.
  2. Staking or stapling layout per manufacturers specifications.

**Figure 4-4 Channel Installation**

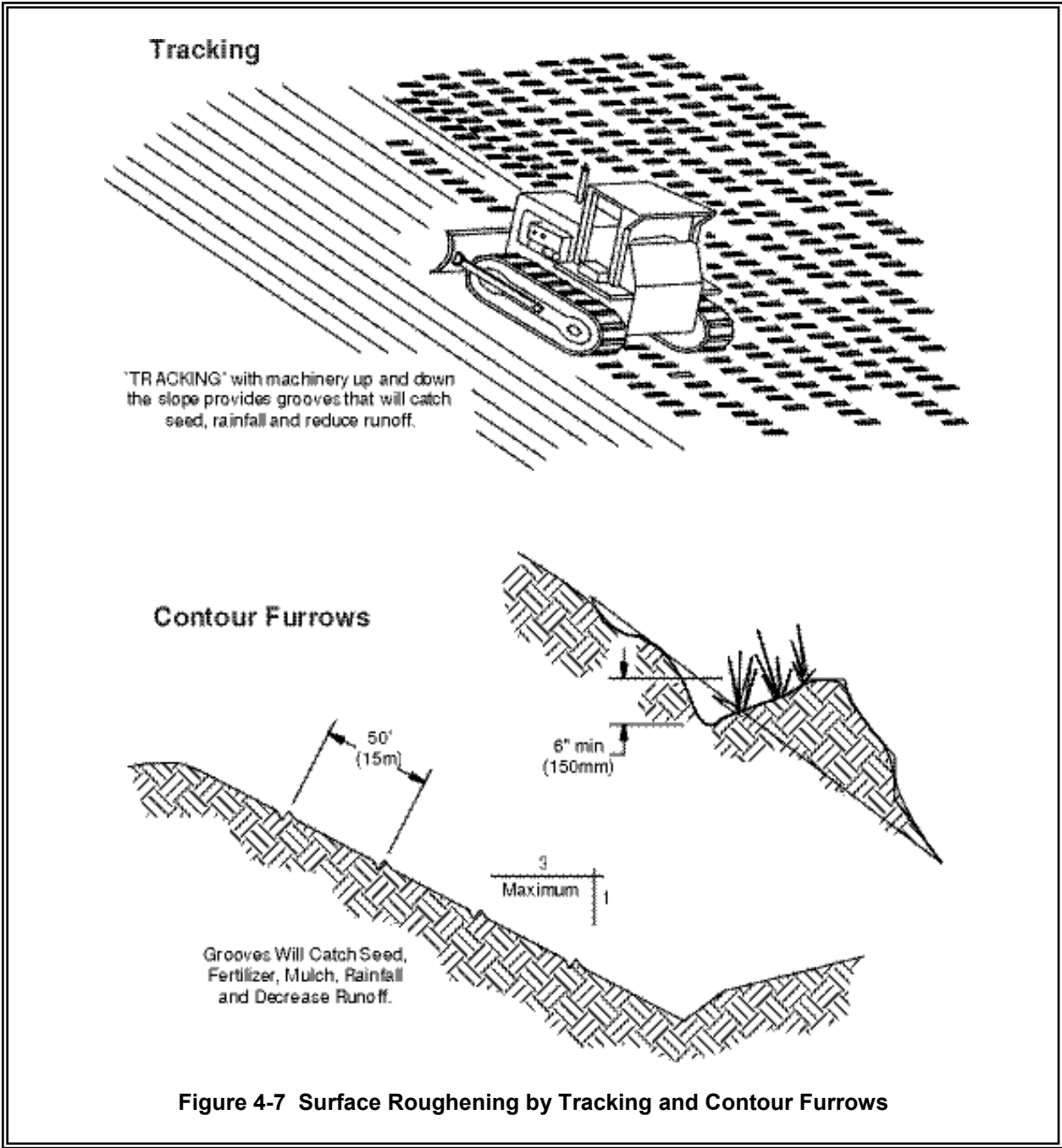


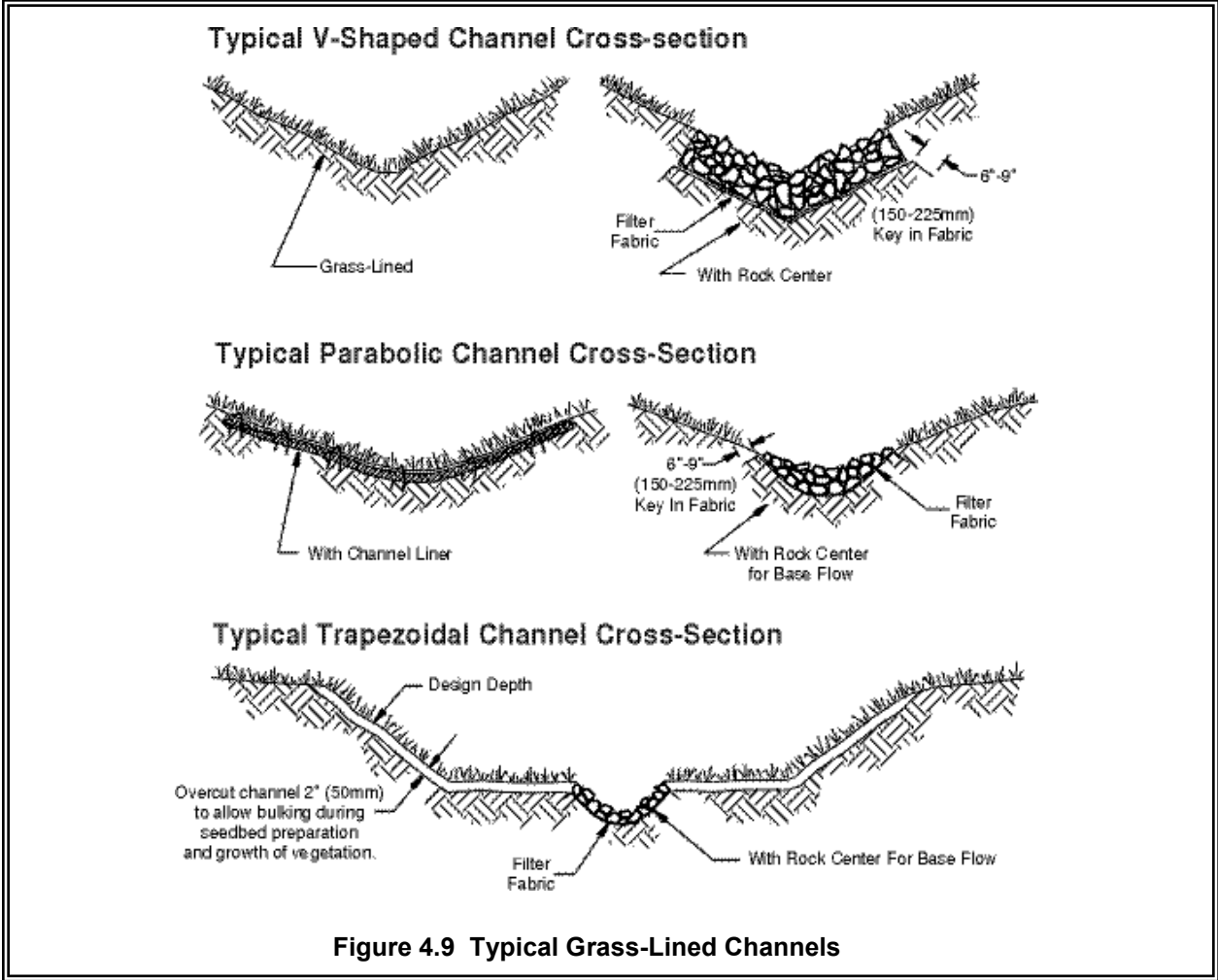
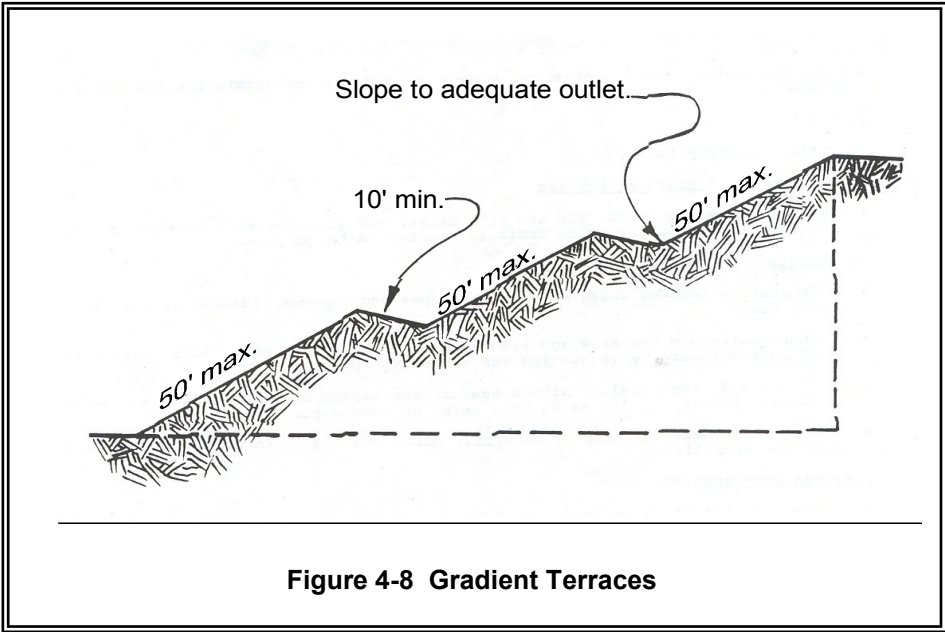
**Figure 4-5 Slope Installation**

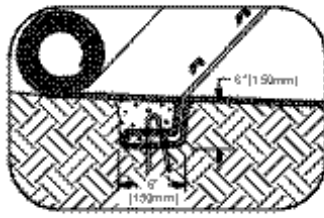
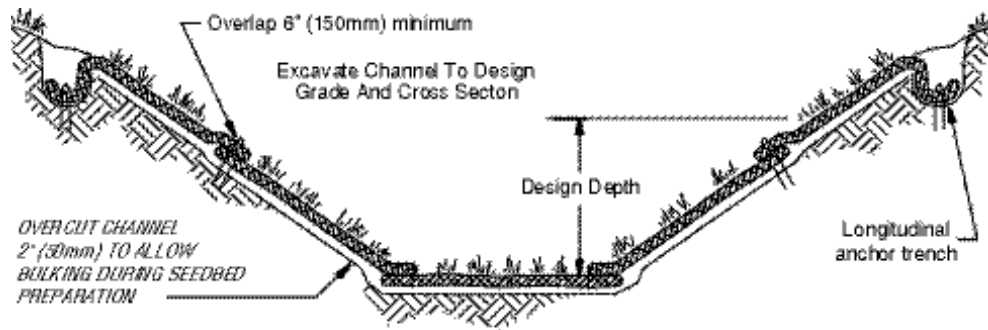


**Figure 4-6 PAM and Water Application Rates**



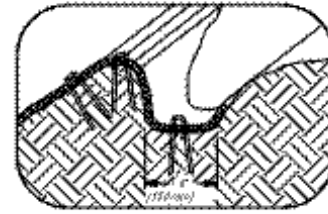






Intermittent Check Slot

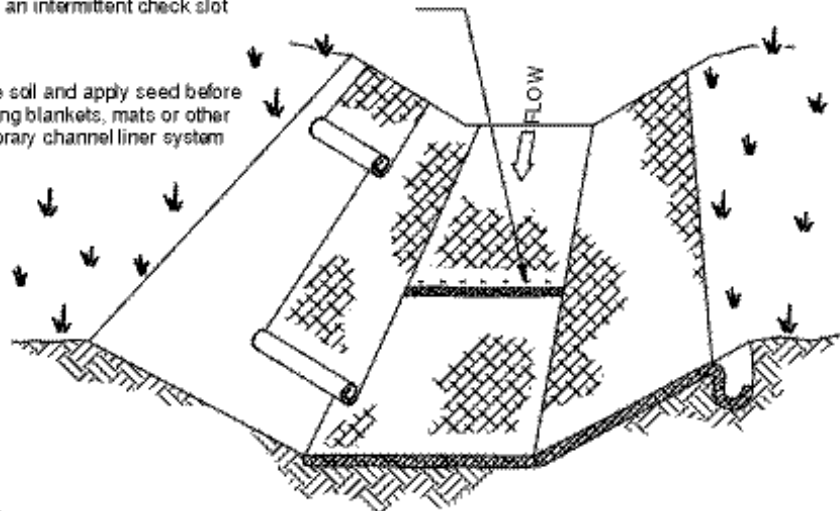
TYPICAL INSTALLATION WITH EROSION CONTROL BLANKETS OR TURF REINFORCEMENT MATS



Longitudinal Anchor Trench

Shingle-lap spliced ends or begin new roll in an intermittent check slot

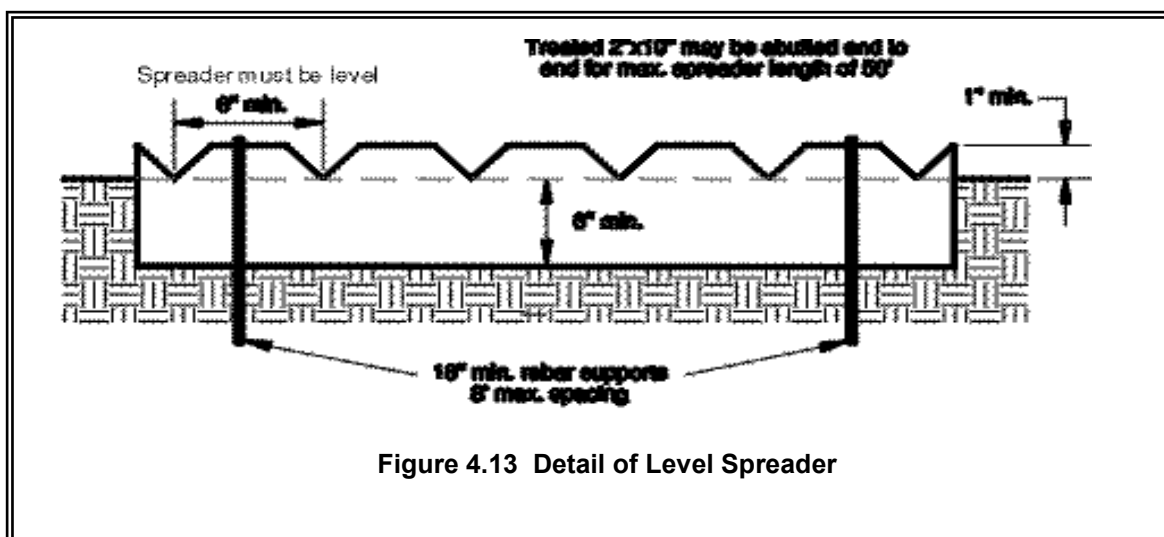
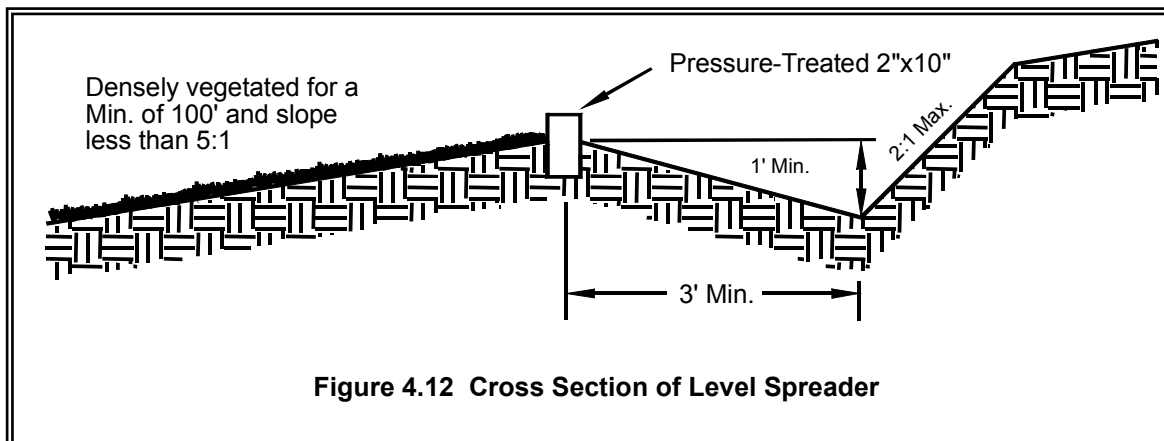
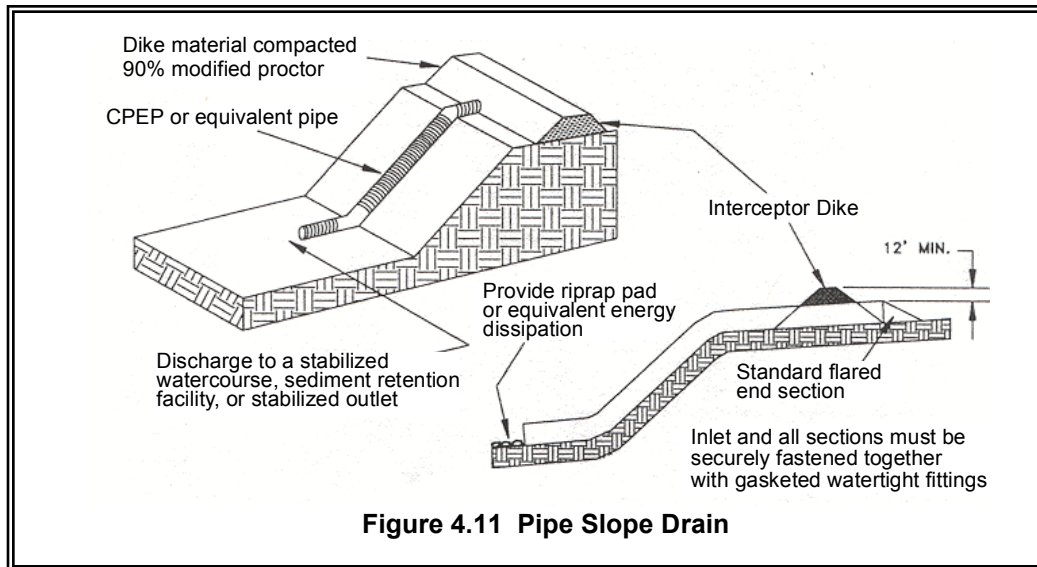
Prepare soil and apply seed before installing blankets, mats or other temporary channel liner system



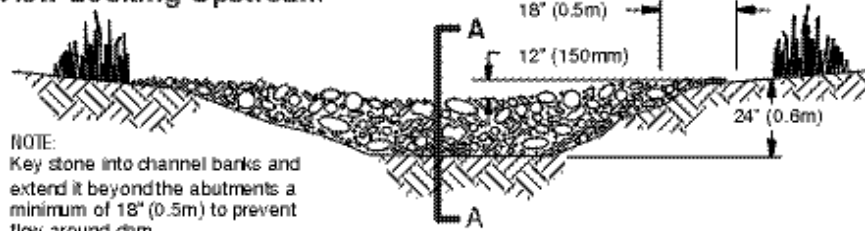
NOTES:

1. Design velocities exceeding 2 ft/sec (0.5m/sec) require temporary blankets, mats or similar liners to protect seed and soil until vegetation becomes established.
2. Grass-lined channels with design velocities exceeding 6 ft/sec (2m/sec) should include turf reinforcement mats.

Figure 4.10 Temporary Channel Liners

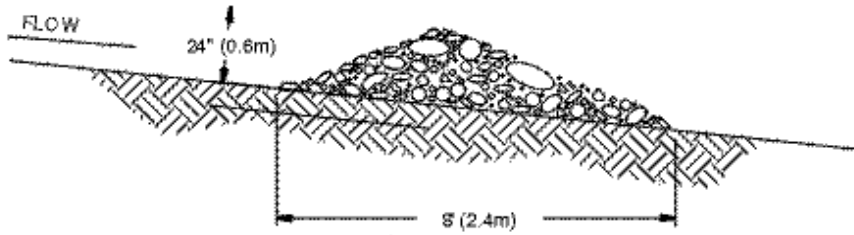


### View Looking Upstream



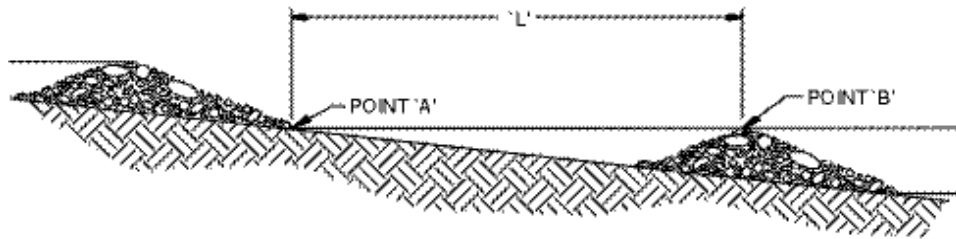
NOTE:  
Key stone into channel banks and extend it beyond the abutments a minimum of 18" (0.5m) to prevent flow around dam.

### Section A - A



### Spacing Between Check Dams

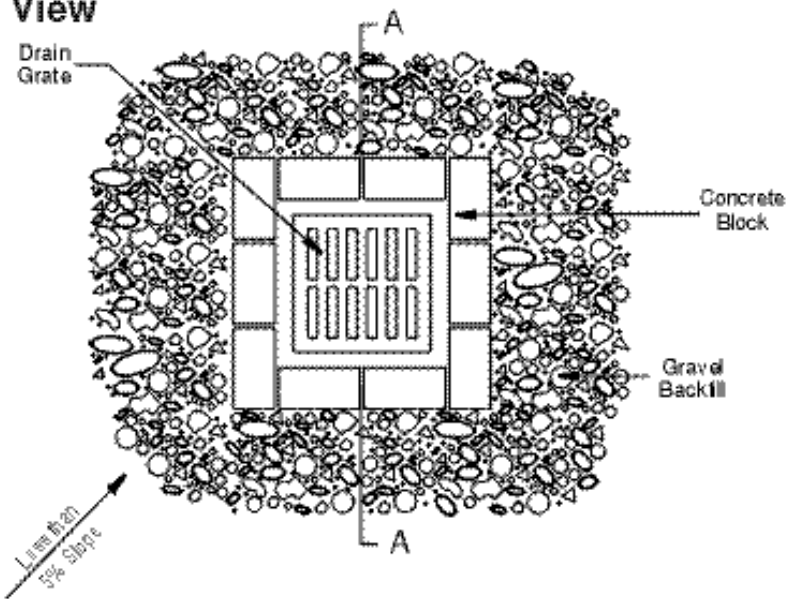
'L' = the distance such that points 'A' and 'B' are of equal elevation.



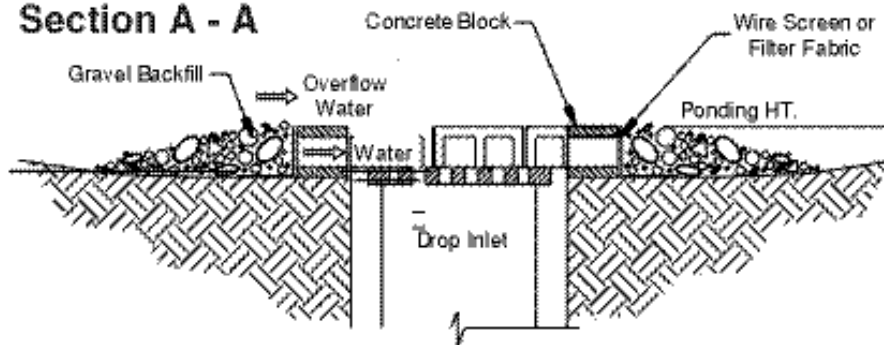
NOT TO SCALE

Figure 4.14 Check Dams

### Plan View



### Section A - A

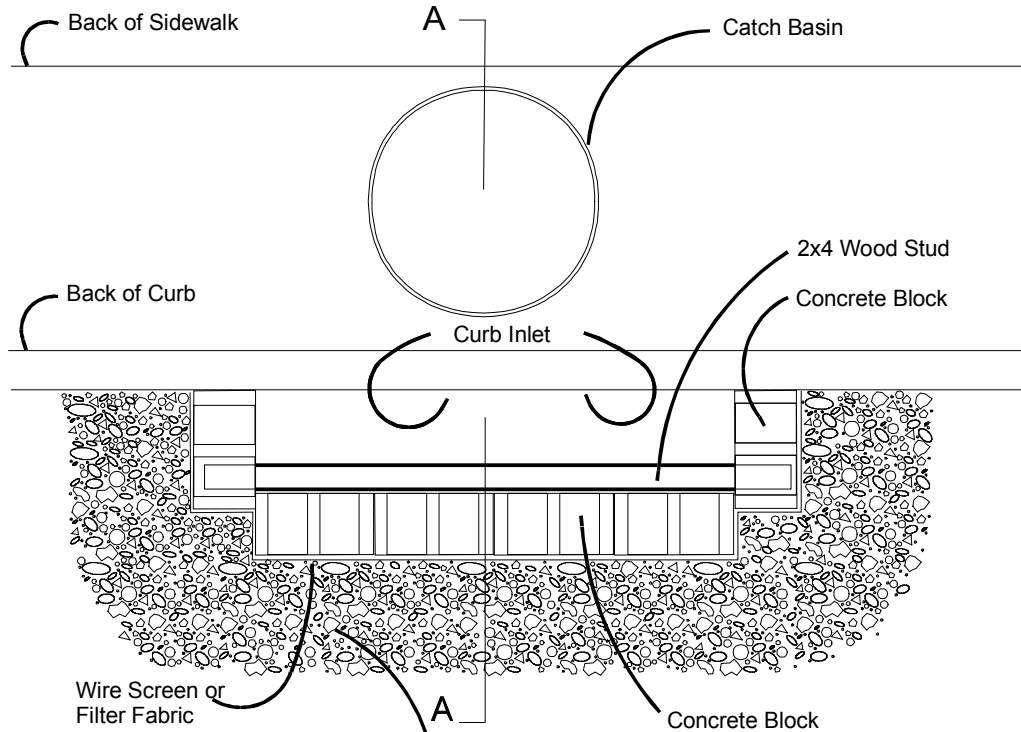


#### NOTES:

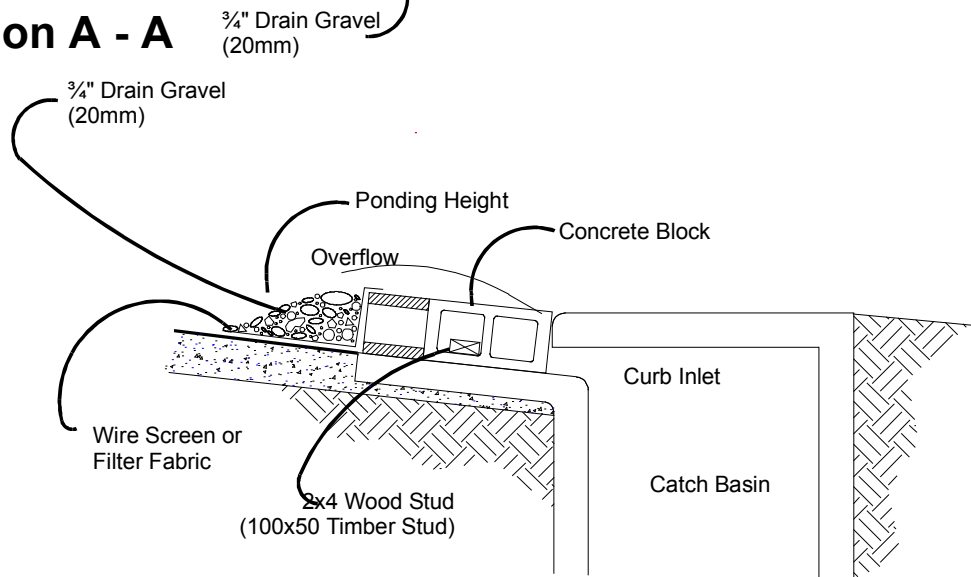
1. Drop inlet sediment barriers are to be used for small, nearly level drainage areas. (less than 5%)
2. Excavate a basin of sufficient size adjacent to the drop inlet.
3. The top of the structure (ponding height) must be well below the ground elevation downslope to prevent runoff from bypassing the inlet. a temporary dike may be necessary on the downslope side of the structure.

**Figure 4.15 Block and Gravel Filter**

## Plan View



## Section A - A

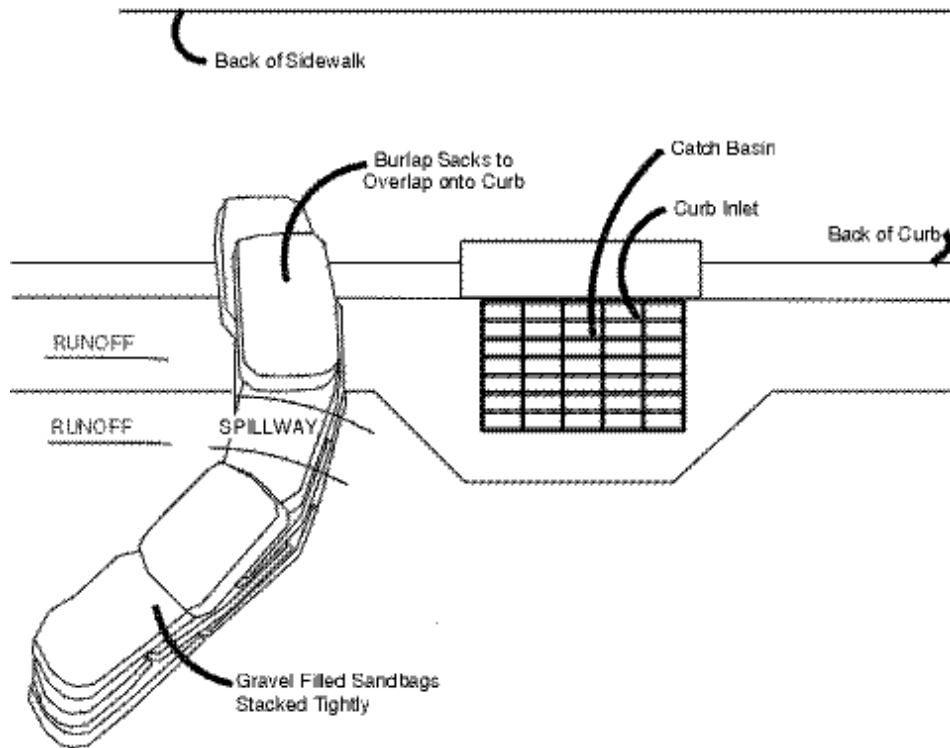


### NOTES:

1. Use block and gravel type sediment barrier when curb inlet is located in gently sloping street segment, where water can pond and allow sediment to separate from runoff.
2. Barrier shall allow for overflow from severe storm event.
3. Inspect barriers and remove sediment after each storm event. Sediment and gravel must be removed from the traveled way immediately.

**Figure 4.16 Block and Gravel Curb [Inlet Protection](#)**

## Plan View

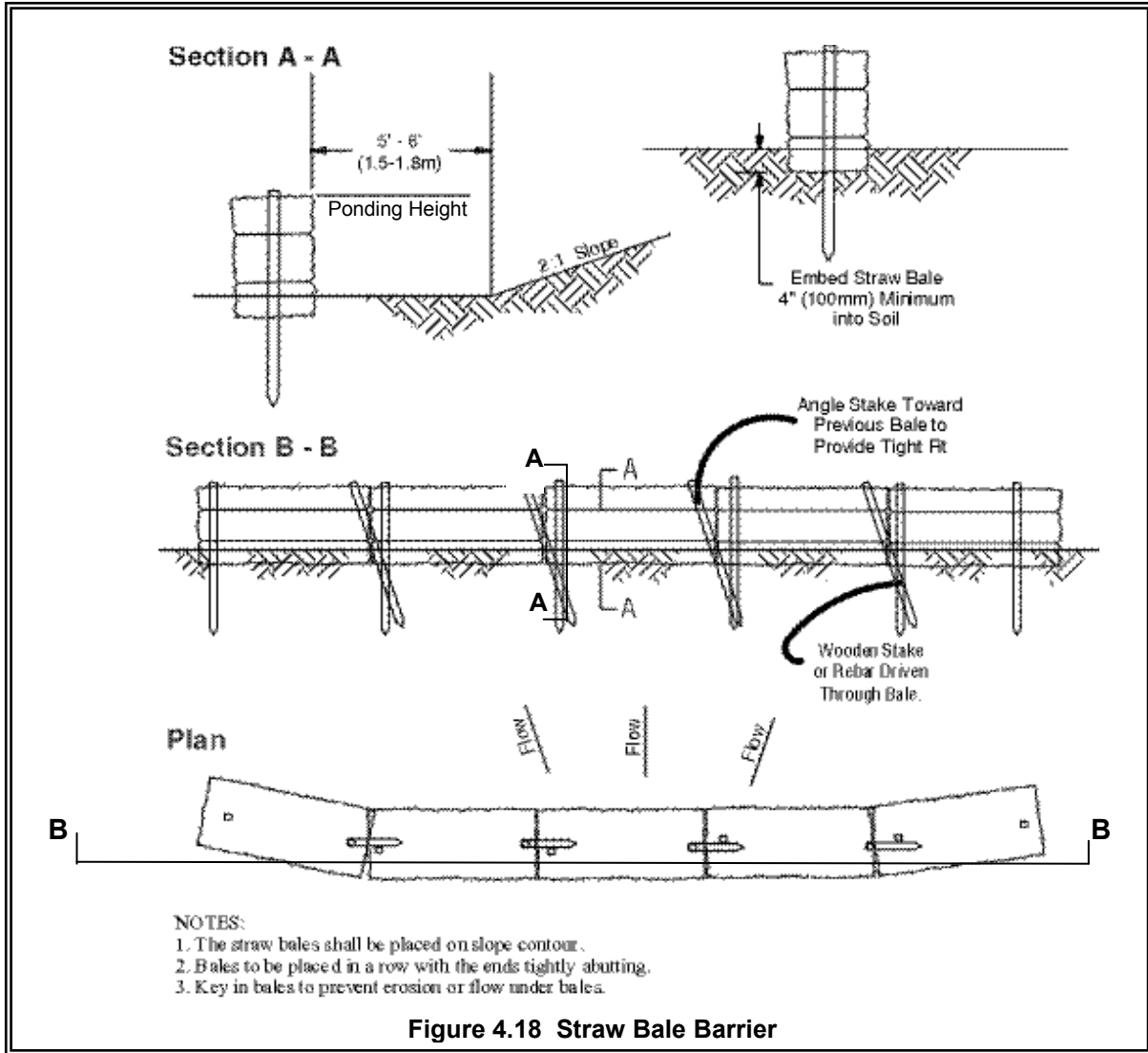


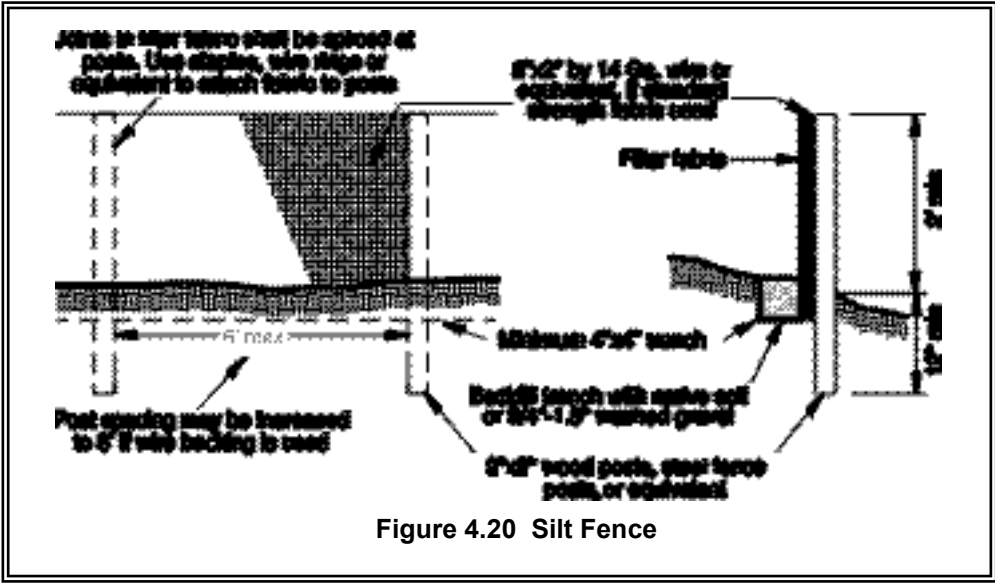
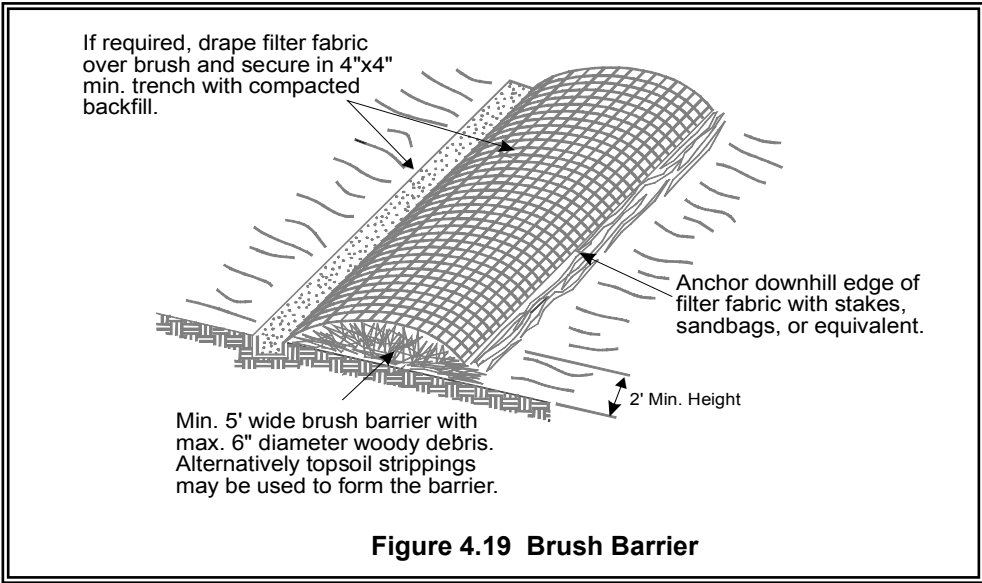
### NOTES:

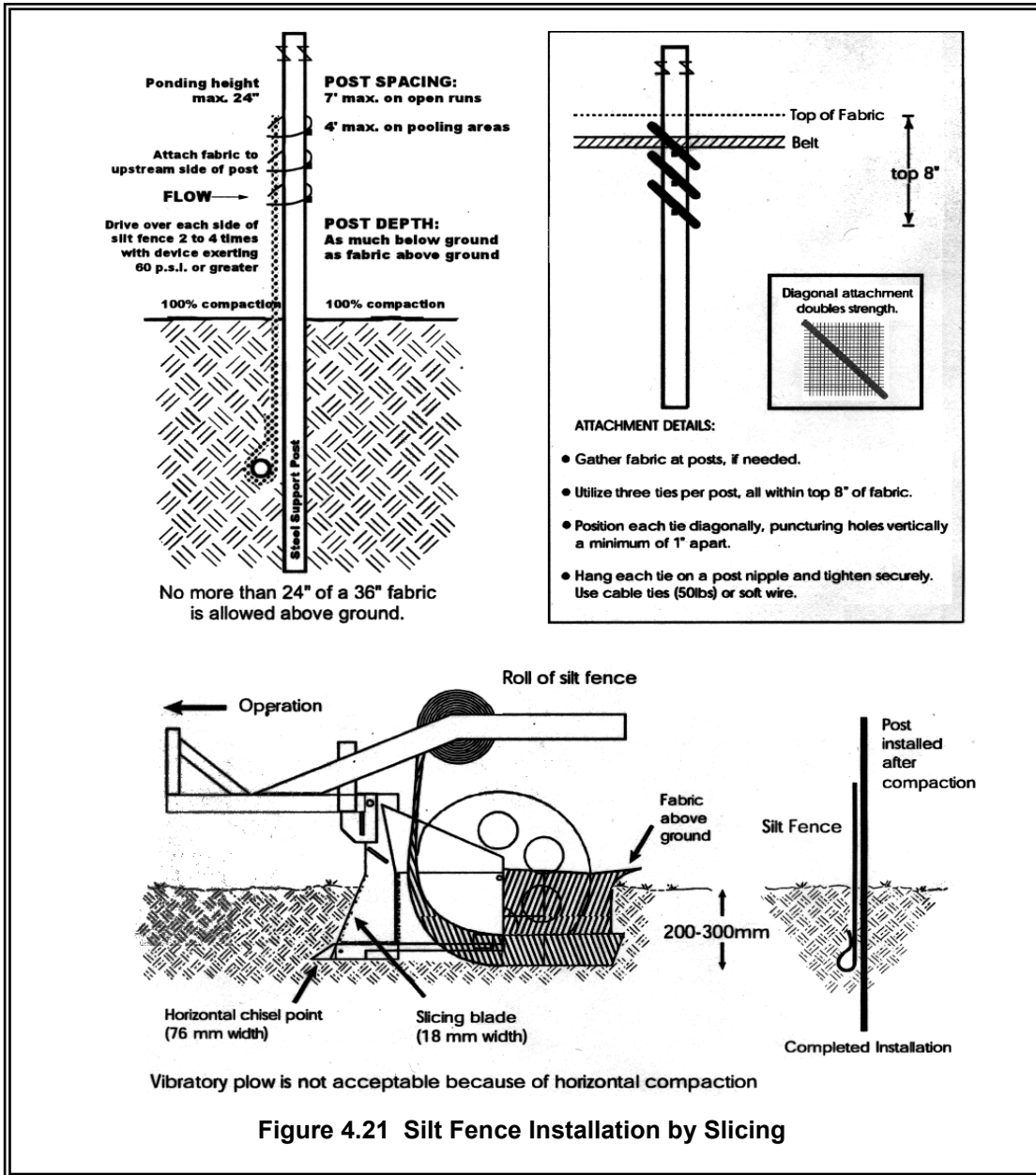
1. Place curb type sediment barriers on gently sloping street segments, where water can pond and allow sediment to separate from runoff.
2. Sandbags of either burlap or woven 'geotextile' fabric, are filled with gravel, layered and packed tightly.
3. Leave a one sandbag gap in the top row to provide a spillway for overflow.
4. Inspect barriers and remove sediment after each storm event. Sediment and gravel must be removed from the traveled way immediately.

**Figure 4.17 Curb and Gutter Barrier**

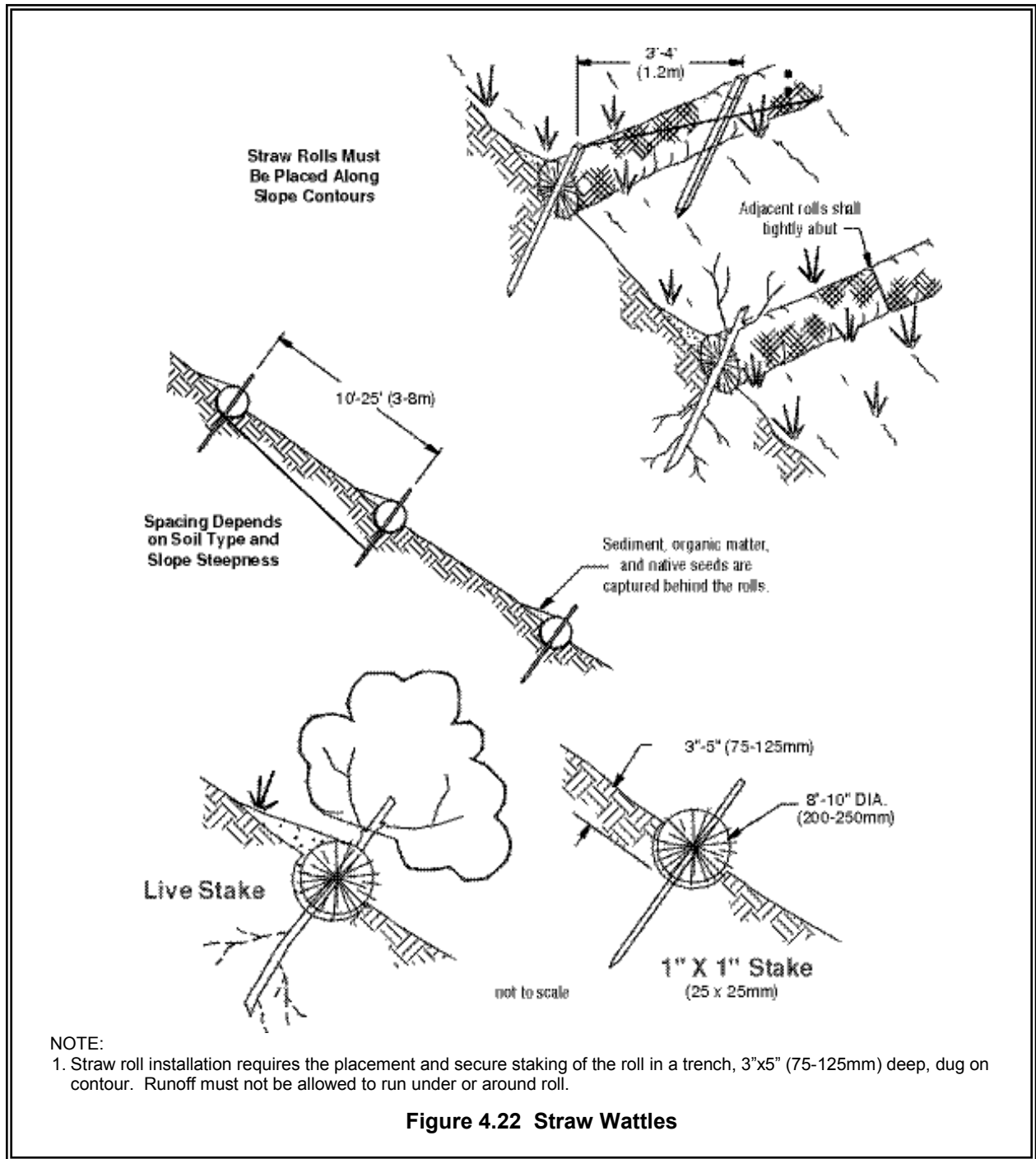




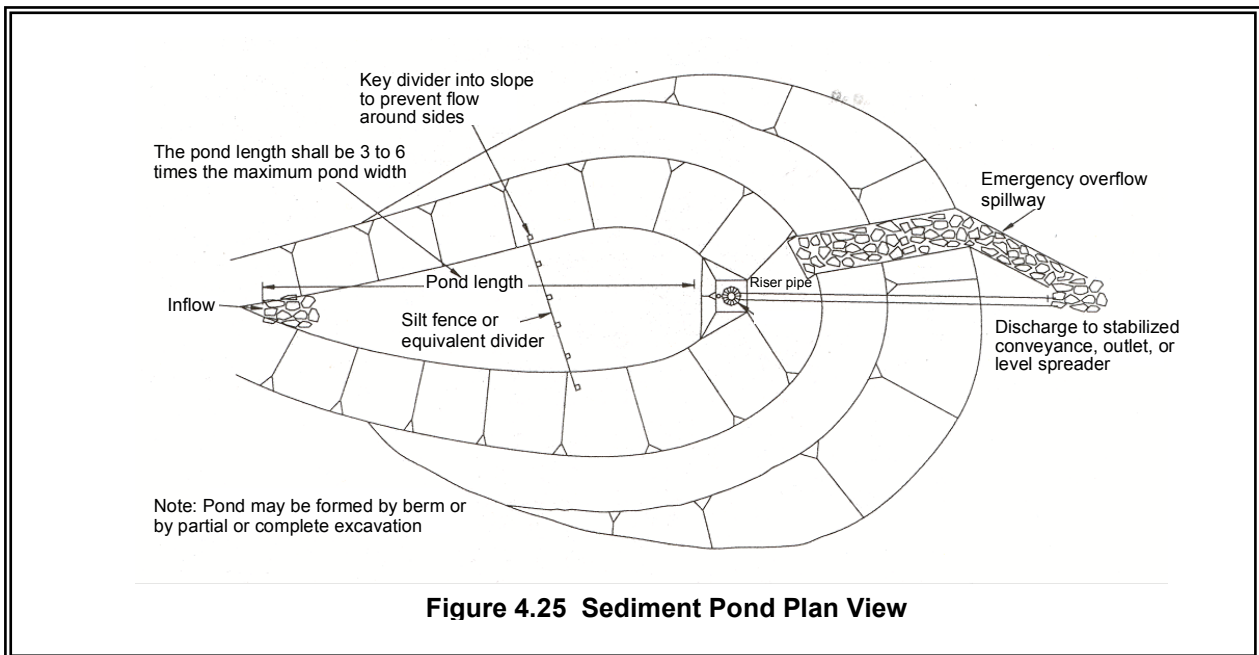
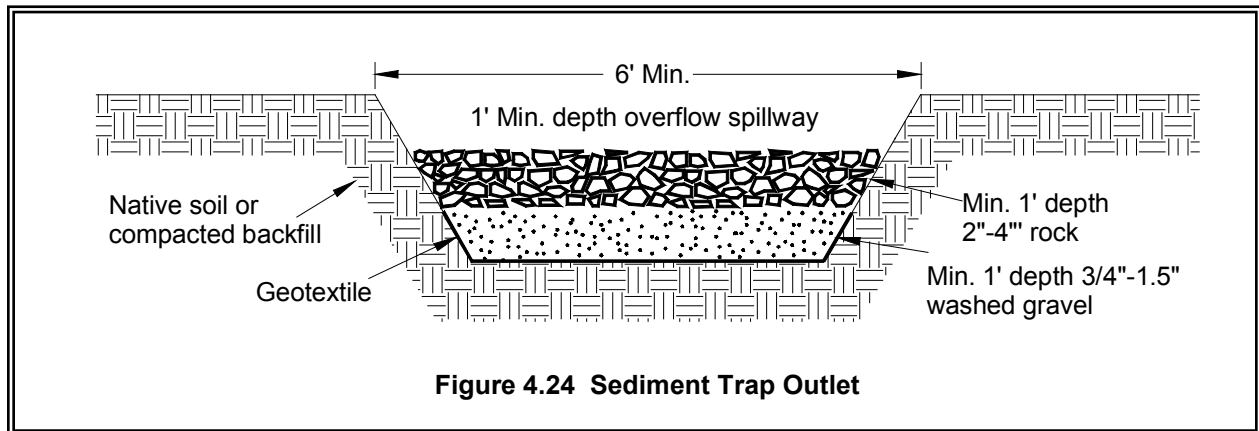
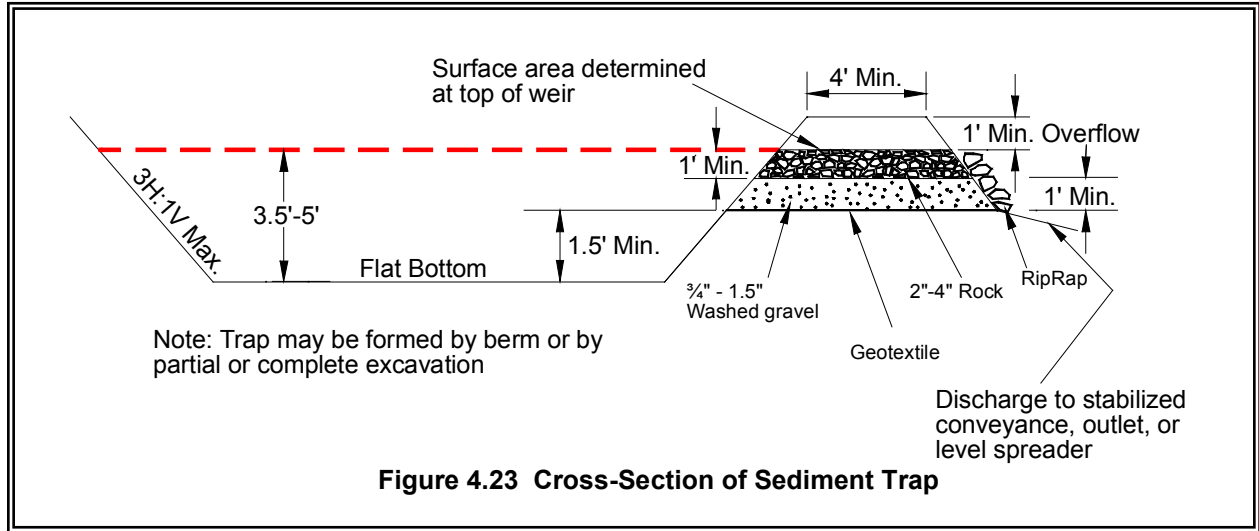


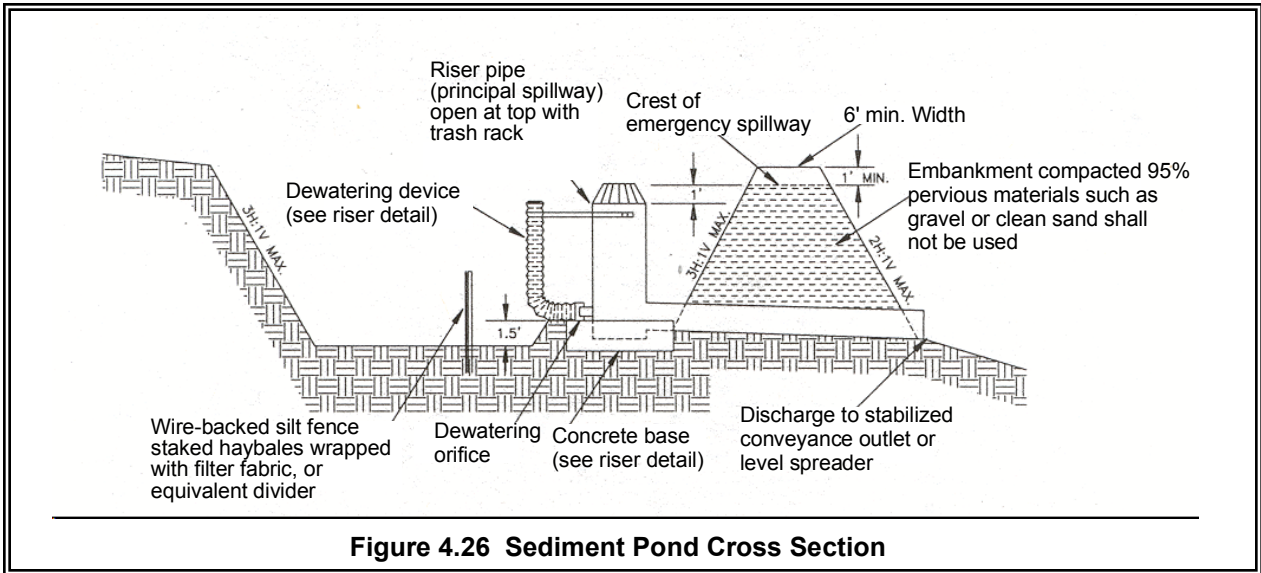


**Figure 4.21 Silt Fence Installation by Slicing**

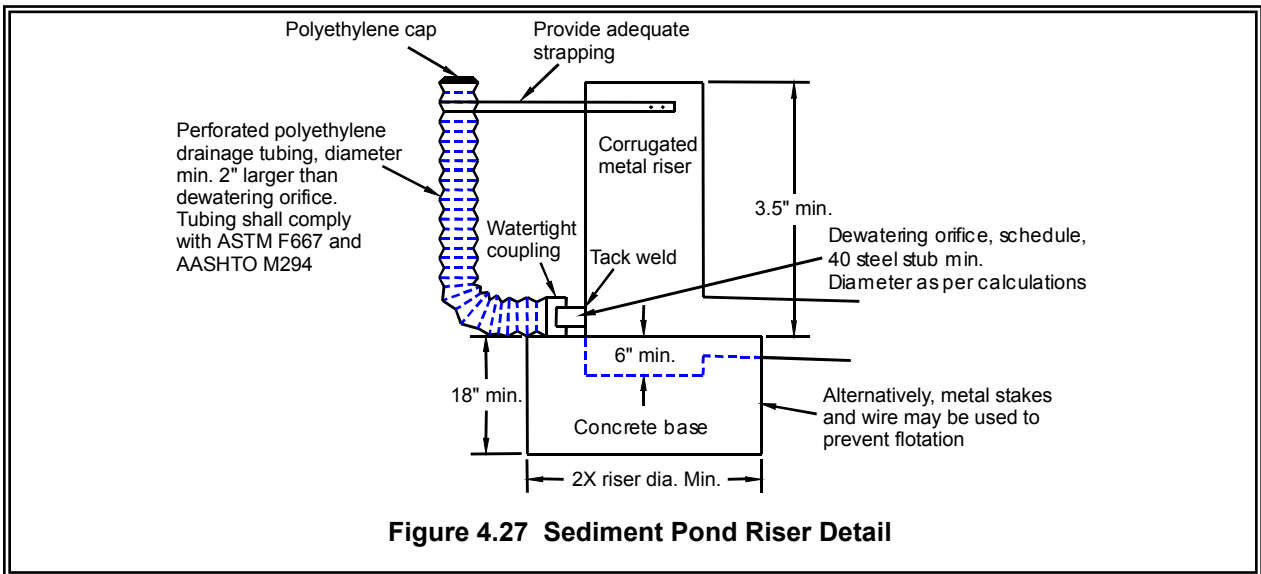


**Figure 4.22 Straw Wattles**

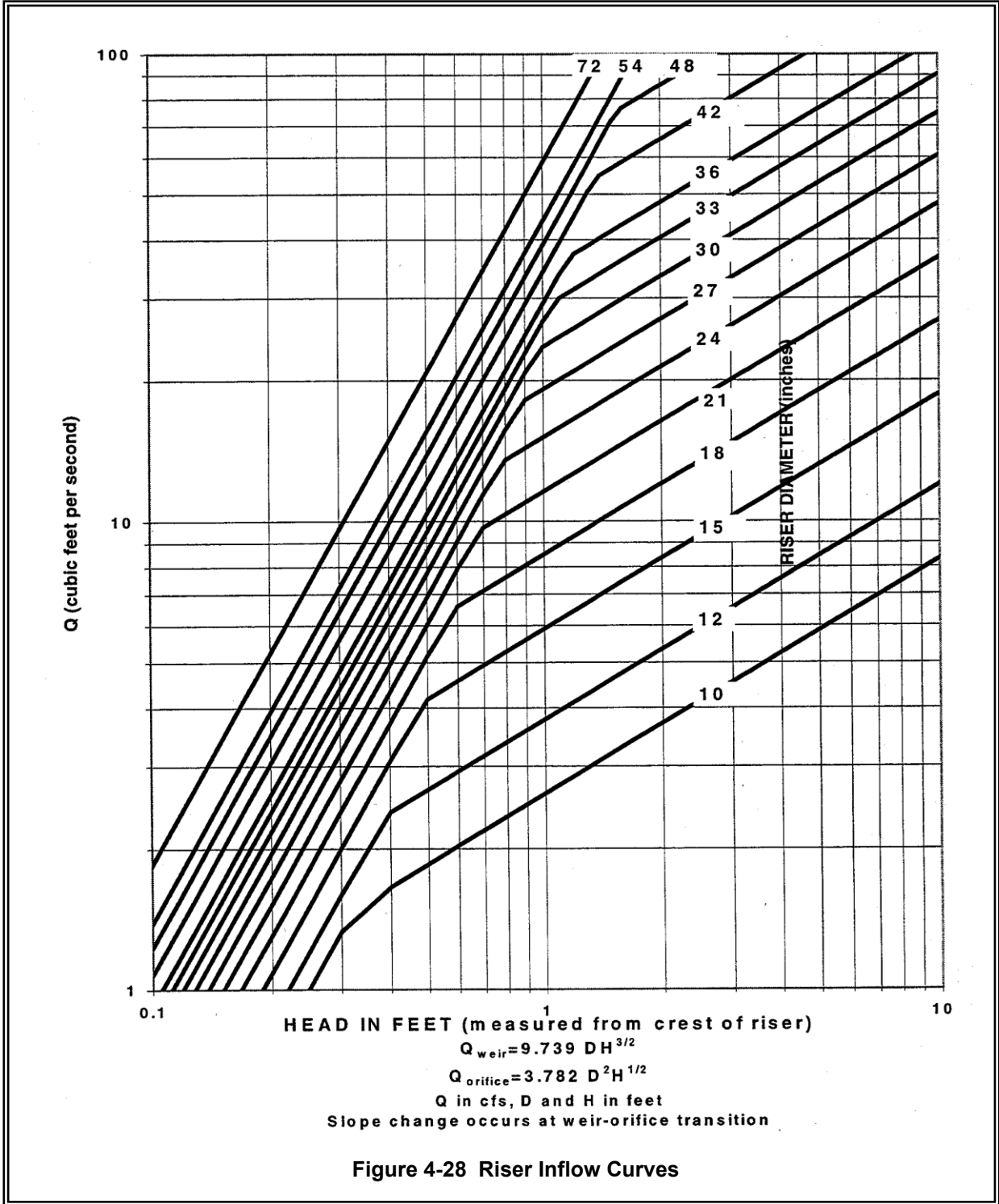




**Figure 4.26 Sediment Pond Cross Section**



**Figure 4.27 Sediment Pond Riser Detail**



## Resource Materials

---

Association of General Contractors of Washington, Water Quality Manual.

Clark County Conservation District, Erosion and Runoff Control, January 1981.

King County Conservation District, Construction and Erosion Control, December 1981.

King County Department of Transportation Road Maintenance BMP Manual (Final Draft), May 1998.

King County Surface Water Design Manual, September 1998.

Maryland Erosion and Sedimentation Control Manual, 1983.

Michigan State Guidebook for Erosion and Sediment Control, 1975.

Snohomish County Addendum to the 1992 Ecology Stormwater Management Manual for the Puget Sound Basin, September 1998.

University of Washington, by Loren Reinelt, Construction Site Erosion and Sediment Control Inspector Training Manual, Center for Urban Water Resources Management, October 1991.

University of Washington, by Loren Reinelt, Processes, Procedures, and Methods to Control Pollution Resulting from all Construction Activity, Center for Urban Water Resources Management, October 1991.

Virginia Erosion and Sediment Control Handbook, 2<sup>nd</sup> Edition, 1980.





## **Appendix II-A**

### **Recommended Standard Notes for Erosion Control Plans**

---

The following standard notes are suggested for use in erosion control plans. Local jurisdictions may have other mandatory notes for construction plans that are applicable. Plans should also identify with phone numbers the person or firm responsible for the preparation of and maintenance of the erosion control plan.

#### **Standard Notes**

Approval of this erosion/sedimentation control (ESC) plan does not constitute an approval of permanent road or drainage design (e.g. size and location of roads, pipes, restrictors, channels, retention facilities, utilities, etc.).

The implementation of these ESC plans and the construction, maintenance, replacement, and upgrading of these ESC facilities is the responsibility of the applicant/contractor until all construction is completed and approved and vegetation/landscaping is established.

The boundaries of the clearing limits shown on this plan shall be clearly flagged in the field prior to construction. During the construction period, no disturbance beyond the flagged clearing limits shall be permitted. The flagging shall be maintained by the applicant/contractor for the duration of construction.

The ESC facilities shown on this plan must be constructed in conjunction with all clearing and grading activities, and in such a manner as to insure that sediment and sediment laden water do not enter the drainage system, roadways, or violate applicable water standards.

The ESC facilities shown on this plan are the minimum requirements for anticipated site conditions. During the construction period, these ESC facilities shall be upgraded as needed for unexpected storm events and to ensure that sediment and sediment-laden water do not leave the site.

The ESC facilities shall be inspected daily by the applicant/contractor and maintained as necessary to ensure their continued functioning.

The ESC facilities on inactive sites shall be inspected and maintained a minimum of once a month or within the 48 hours following a major storm event.

At no time shall more than one foot of sediment be allowed to accumulate within a trapped catch basin. All catch basins and conveyance lines shall be cleaned prior to paving. The cleaning operation shall not flush sediment-laden water into the downstream system.

Stabilized construction entrances shall be installed at the beginning of construction and maintained for the duration of the project. Additional measures may be required to insure that all paved areas are kept clean for the duration of the project.



## Appendix II-B

# Background Information on Chemical Treatment

---

Coagulation and flocculation have been used for over a century to treat water. It is used less frequently for the treatment of wastewater. The use of coagulation and flocculation for treating stormwater is a very recent application. Experience with the treatment of water and wastewater has resulted in a basic understanding of the process, in particular factors that affect performance. This experience can provide insights as to how to most effectively design and operate similar systems in the treatment of stormwater.

Fine particles suspended in water give it a milky appearance, measured as turbidity. Their small size, often much less than 1  $\mu\text{m}$  in diameter, give them a very large surface area relative to their volume. These fine particles typically carry a negative surface charge. Largely because of these two factors, small size and negative charge, these particles tend to stay in suspension for extended periods of time. Thus, removal is not practical by gravity settling. These are called stable suspensions. Polymers, as well as inorganic chemicals such as alum, speed the process of clarification. The added chemical destabilizes the suspension and causes the smaller particles to agglomerate. The process consists of three steps: coagulation, flocculation, and settling or clarification. Each step is explained below as well as the factors that affect the efficiency of the process.

Coagulation: Coagulation is the first step. It is the process by which negative charges on the fine particles that prevent their agglomeration are disrupted. Chemical addition is one method of destabilizing the suspension, and polymers are one class of chemicals that are generally effective. Chemicals that are used for this purpose are called coagulants. Coagulation is complete when the suspension is destabilized by the neutralization of the negative charges. Coagulants perform best when they are thoroughly and evenly dispersed under relatively intense mixing. This rapid mixing involves adding the coagulant in a manner that promotes rapid dispersion, followed by a short time period for destabilization of the particle suspension. The particles are still very small and are not readily separated by clarification until flocculation occurs.

Flocculation: Flocculation is the process by which fine particles that have been destabilized bind together to form larger particles that settle rapidly. Flocculation begins naturally following coagulation, but is enhanced by gentle mixing of the destabilized suspension. Gentle mixing helps to bring particles in contact with one another such that they bind and continually grow to form "flocs." As the size of the flocs increases they become heavier and tend to settle more rapidly.

Clarification: The final step is the settling of the particles. Particle density, size and shape are important during settling. Dense, compact flocs settle more readily than less dense, fluffy flocs. Because of this, flocculation to form dense, compact flocs is particularly important during water treatment. Water temperature is important during settling. Both the density and viscosity of water are affected by temperature; these in turn affect settling. Cold temperatures increase viscosity and density, thus slowing down the rate at which the particles settle.

The conditions under which clarification is achieved can affect performance. Currents can affect settling. Currents can be produced by wind, by differences between the temperature of the incoming water and the water in the clarifier, and by flow conditions near the inlets and outlets.

Quiescent water such as that which occurs during batch clarification provides a good environment for effective performance as many of these factors become less important in comparison to typical sedimentation basins. One source of currents that is likely important in batch systems is movement of the water leaving the clarifier unit. Given that flocs are relatively small and light the exit velocity of the water must be as low as possible. Sediment on the bottom of the basin can be resuspended and removed by fairly modest velocities.

Coagulants: Polymers are large organic molecules that are made up of subunits linked together in a chain-like structure. Attached to these chain-like structures are other groups that carry positive or negative charges, or have no charge. Polymers that carry groups with positive charges are called cationic, those with negative charges are called anionic, and those with no charge (neutral) are called nonionic.

Cationic polymers can be used as coagulants to destabilize negatively charged turbidity particles present in natural waters, wastewater and stormwater. Aluminum sulfate (alum) can also be used as this chemical becomes positively charged when dispersed in water. In practice, the only way to determine whether a polymer is effective for a specific application is to perform preliminary or on-site testing.

Polymers are available as powders, concentrated liquids, and emulsions (which appear as milky liquids). The latter are petroleum based, which are not allowed for construction stormwater treatment. Polymer effectiveness can degrade with time and also from other influences. Thus, manufacturers' recommendations for storage should be followed. Manufacturers' recommendations usually do not provide assurance of water quality protection or safety to aquatic organisms. Consideration of water quality protection is necessary in the selection and use of all polymers.

Application Considerations: Application of coagulants at the appropriate concentration or dosage rate for optimum turbidity removal is important for management of chemical cost, for effective performance, and to avoid aquatic toxicity. The optimum dose in a given application depends on several site-specific features. Turbidity of untreated water can be important with turbidities greater than 5,000 NTU. The surface charge of particles to be removed is also important. Environmental factors that can influence dosage rate are water temperature, pH, and the presence of constituents that consume or otherwise affect polymer effectiveness. Laboratory experiments indicate that mixing previously settled sediment (floc sludge) with the untreated stormwater significantly improves clarification, therefore reducing the effective dosage rate. Preparation of working solutions and thorough dispersal of polymers in water to be treated is also important to establish the appropriate dosage rate.

For a given water sample, there is generally an optimum dosage rate that yields the lowest residual turbidity after settling. When dosage rates below this optimum value (underdosing) are applied, there is an insufficient quantity of coagulant to react with, and therefore destabilize, all of the turbidity present. The result is residual turbidity (after flocculation and settling) that is higher than with the optimum dose. Overdosing, application of dosage rates greater than the optimum value, can also negatively impact performance. Again, the result is higher residual turbidity than that with the optimum dose.

Mixing in Coagulation/Flocculation: The G-value, or just "G", is often used as a measure of the mixing intensity applied during coagulation and flocculation. The symbol G stands for "velocity gradient", which is related in part to the degree of turbulence generated during mixing. High G-values mean high turbulence, and vice versa. High G-values provide the best conditions for

coagulant addition. With high Gs, turbulence is high and coagulants are rapidly dispersed to their appropriate concentrations for effective destabilization of particle suspensions.

Low G-values provide the best conditions for flocculation. Here, the goal is to promote formation of dense, compact flocs that will settle readily. Low Gs provide low turbulence to promote particle collisions so that flocs can form. Low Gs generate sufficient turbulence such that collisions are effective in floc formation, but do not break up flocs that have already formed.

Design engineers wishing to review more detailed presentations on this subject are referred to the following textbooks.

- Fair, G., J. Geyer and D. Okun, *Water and Wastewater Engineering*, Wiley and Sons, NY, 1968.
- American Water Works Association, *Water Quality and Treatment*, McGraw-Hill, NY, 1990.
- Weber, W.J., *Physiochemical Processes for Water Quality Control*, Wiley and Sons, NY, 1972.

Polymer Batch Treatment Process Description: Stormwater is collected at interception point(s) on the site and is diverted by gravity or by pumping to a storage pond or other holding area. The stormwater is stored until treatment occurs. It is important that the holding pond be large enough to provide adequate storage.

The first step in the treatment sequence is to check the pH of the stormwater in the storage pond. The pH is adjusted by the application of acid or base until the stormwater in the storage pond is within the desired pH range. When used, acid is added immediately downstream of the transfer pump. Typically sodium bicarbonate (baking soda) is used as a base, although other bases may be used. When needed, base is added directly to the storage pond. The stormwater is recirculated with the treatment pump to provide mixing in the storage pond. Initial pH adjustments should be based on daily bench tests. Further pH adjustments can be made at any point in the process.

Once the stormwater is within the desired pH range, the stormwater is pumped from the storage pond to a treatment cell as polymer is added. The polymer is added upstream of the pump to facilitate rapid mixing.

After polymer addition, the water is kept in a lined treatment cell for clarification of the sediment-floc. In a batch mode process, clarification typically takes from 30 minutes to several hours. Prior to discharge samples are withdrawn for analysis of pH and turbidity. If both are acceptable, the treated water is discharged.

Several configurations have been developed to withdraw treated water from the treatment cell. The original configuration is a device that withdraws the treated water from just beneath the water surface using a float with adjustable struts that prevent the float from settling on the cell bottom. This reduces the possibility of picking up sediment-floc from the bottom of the pond. The struts are usually set at a minimum clearance of about 12 inches; that is, the float will come within 12 inches of the bottom of the cell. Other systems have used vertical guides or cables, which constrain the float, allowing it to drift up and down with the water level. More recent designs have an H-shaped array of pipes, set on the horizontal.

This scheme provides for withdrawal from four points rather than one. This configuration reduces the likelihood of sucking settled solids from the bottom. It also reduces the tendency for a vortex to form. Inlet diffusers, a long floating or fixed pipe with many small holes in it, are also an option.

Safety is a primary concern. Design should consider the hazards associated with operations, such as sampling. Facilities should be designed to reduce slip hazards and drowning. Tanks and ponds should have life rings, ladders, or steps extending from the bottom to the top.

Adjustment of the pH and Alkalinity: The pH must be in the proper range for the polymers to be effective, which is 6.5 to 8.5 for Calgon CatFloc 2953, the most commonly used polymer. As polymers tend to lower the pH, it is important that the stormwater have sufficient buffering capacity. Buffering capacity is a function of alkalinity. Without sufficient alkalinity, the application of the polymer may lower the pH to below 6.5. A pH below 6.5 not only reduces the effectiveness of the polymer, it may create a toxic condition for aquatic organisms. Stormwater may not be discharged without readjustment of the pH to above 6.5. The target pH should be within 0.2 standard units of the receiving water pH.

Experience gained at several projects in the City of Redmond has shown that the alkalinity needs to be at least 50 mg/L to prevent a drop in pH to below 6.5 when the polymer is added. Baking soda has been used to raise both the alkalinity and the pH. Although lime is less expensive than baking soda, if overdosed, lime can raise the pH above 8.5 requiring downward adjustment for the polymer to be effective. Baking soda has the advantage of not raising the pH above 8.3 regardless of the amount that is added. Experience indicates that the amount of baking soda sufficient to raise the alkalinity to above 50 mg/L produces a pH near neutral or 7.

Alkalinity cannot be easily measured in the field. Therefore, conductivity, which can be measured directly with a hand-held probe, has been used to ascertain the buffering condition. It has been found through local experience that when the conductivity is above about 100  $\mu$ S/cm the alkalinity is above 50 mg/L. This relationship may not be constant and therefore care must be taken to define the relationship for each site.

Experience has shown that the placement of concrete has a significant effect on the pH of construction stormwater. If the area of fresh exposed concrete surface is significant, the pH of the untreated stormwater may be considerably above 8.5. Concrete equipment washwater shall be controlled to prevent contact with stormwater. Acid may be added to lower the pH to the background level pH of the receiving water. The amount of acid needed to adjust the pH to the desired level is not constant but depends upon the polymer dosage, and the pH, turbidity, and alkalinity of the untreated stormwater. The acid commonly used is sulfuric although muriatic and ascorbic acids have been used. Pelletized dry ice has also been used and reduces the safety concerns associated with handling acid.

## **Appendix II-C**

# **Small Site Educational Hand-Out**

---

This Appendix is currently under development.





# Appendix II-D

## Construction SWPPP Short Form

---

# CITY OF TACOMA CONSTRUCTION STORMWATER POLLUTION PREVENTION PLAN SHORT FORM

Any project falling within these thresholds may complete this short form instead of preparing a professionally designed Construction Stormwater Pollution Prevention Plan (SWPPP).

Projects that propose to:

1. Add or replace between 2,000 – 5,000 square feet of impervious surface  
OR
2. Clear or disturb between 7,000 square feet to 1 acre of land.

*If your project exceeds either of these thresholds, you must prepare a formal Construction SWPPP as detailed in the City of Tacoma's 2003 Surface Water Manual, Volume II - Construction Stormwater Pollution Prevention.*

---

Project Name/Description: \_\_\_\_\_  
Address: \_\_\_\_\_  
Contact/Owner: \_\_\_\_\_ Phone: \_\_\_\_\_  
Erosion Control Supervisor: \_\_\_\_\_  
Phone: \_\_\_\_\_ Cell: \_\_\_\_\_ Pager: \_\_\_\_\_  
Emergency (After hour) contact: \_\_\_\_\_ Phone: \_\_\_\_\_  
Parcel No.: \_\_\_\_\_

**For City Use Only:**

City Permit No.: \_\_\_\_\_  
Review Date: \_\_\_\_\_  
On-site Pre-construction Inspection Date: \_\_\_\_\_  
Construction SWPPP Reviewer: \_\_\_\_\_

## Required Submittals

### I. Project Narrative

The following Construction Stormwater Pollution Prevention Plan (SWPPP) Short-Form Narrative must be completed as part of this packet. Any information described, as part of the narrative, should be shown on the site plan.

**Note: From October 1 thru April 30, clearing, grading and other soil disturbing activities shall only be permitted by special authorization from the City of Tacoma Building and Land Use Department.**

#### A. Project Description (Check all that apply)

New Structure  Building Addition  Grading/Excavation  Paving  
 Utilities  Other \_\_\_\_\_

1. Total project area \_\_\_\_\_ (square feet)
2. Total proposed impervious area \_\_\_\_\_ (square feet)
3. Total existing impervious area \_\_\_\_\_ (square feet)
4. Total proposed area to be disturbed \_\_\_\_\_ (square feet).
5. Total volumes of proposed cuts/fill \_\_\_\_\_ (cubic yards)

Additional Project Information:

---

---

---

---

---

**B. Existing Site Conditions (Check all that apply)**

1. Describe the existing vegetation on the site. (Check all that apply)  
 Forest  Pasture/prairie grass  Pavement  Landscaped  Brush  
 Trees  Other \_\_\_\_\_
2. Describe how surface water (storm water) drainage flows across/from the site.  
(Check all that apply)  
 Sheet Flow  Gutter  Catch Basin  Ditch/Swale  Storm sewer  
 Stream  Other \_\_\_\_\_
3. Describe any unusual site condition(s) or other features of note.  
 Steep Grades  Large depression  Underground tanks  Springs  
 Easements  Existing Structures  Existing Utilities  
 Other \_\_\_\_\_

**C. Adjacent Areas (Check all that apply)**

1. Check any adjacent areas that may be affected by site disturbance and describe in fully describe in item 2 below:

- a. Streams\*  b. Lakes\*  c. Wetlands\*  d. Steep Slopes\*  
 e. Residential Areas  f. Roads  g. Ditches, pipes, culverts  
 h. Other \_\_\_\_\_

2. Describe the downstream drainage path leading from the site to the receiving body of water. (Minimum distance of ¼-mile (1320 feet)) {e.g. water flows from site, into curb-line to catch basin at intersection of X and Y streets. A 10-inch pipe system conveys water another 1000 feet to a ravine/wetland.}

---

---

---

---

---

*\*Note: If site is on or adjacent to a critical area, the City of Tacoma may require additional information, engineering, and other permits to be submitted with this short-form.*

**D. Soils (Check all that apply)**

Does the project propose infiltration? Infiltration systems require prior City approval.

Yes  No  South Tacoma Groundwater Protection District

Does the project propose construction near or on steep slopes?

Yes  No

If infiltration is proposed for the site or if steep slopes have been identified, the City will require soils information as part of the project design. The applicant must contact a soil professional or a civil engineer specializing in soil analysis to perform an in-depth soils investigation. If yes is checked for either question, the City may not permit the use of this short-form.

*Note: The intent of this section is to identify when additional soils information may be required for applicants using this short form. There are other site-specific issues that may necessitate a soils investigation or more extensive erosion control practices. The City will determine these situations on a case-by-case basis as part of their review.*

**E. Construction Sequencing/Phasing**

1. Construction sequence: The standard construction sequence is as follows:
  - Mark clearing/grading limits
  - Call Building Inspector to inspect clearing/grading limits
  - Install initial erosion control practices (construction entrance, silt fence, cb inserts)
  - Contact Building Inspector to inspect initial erosion control practices
  - Clear, grade, fill site as outlined in the site plan while implementing and maintaining temporary erosion and sediment control practices at the same time.
  - Install permanent erosion protection (impervious surface, landscaping, etc.)
  - Contact Building Inspector for approval of permanent erosion protection and site grades.
  - Remove erosion control methods as permitted by the Building Inspector and repair permanent erosion protection as necessary.
  - Monitor and maintain permanent erosion protection until fully established.

List any changes from the standard construction sequence outlined above.

---

---

---

---

---

2. Construction phasing: If construction is going to occur in separate phases describe.

---

---

---

---

---

**F. Construction Schedule**

1. Provide a proposed construction schedule (dates construction starts and ends, and dates for any construction phasing).

Start Date: \_\_\_\_\_ End Date: \_\_\_\_\_

Interim Phasing Dates:

---

2. Wet Season Construction Activities: Wet season occurs from October 1 to April 30. Describe construction activities that will occur during this time period.

*Note: Additional erosion control methods may be required during periods of increased surface water runoff.*

---

---

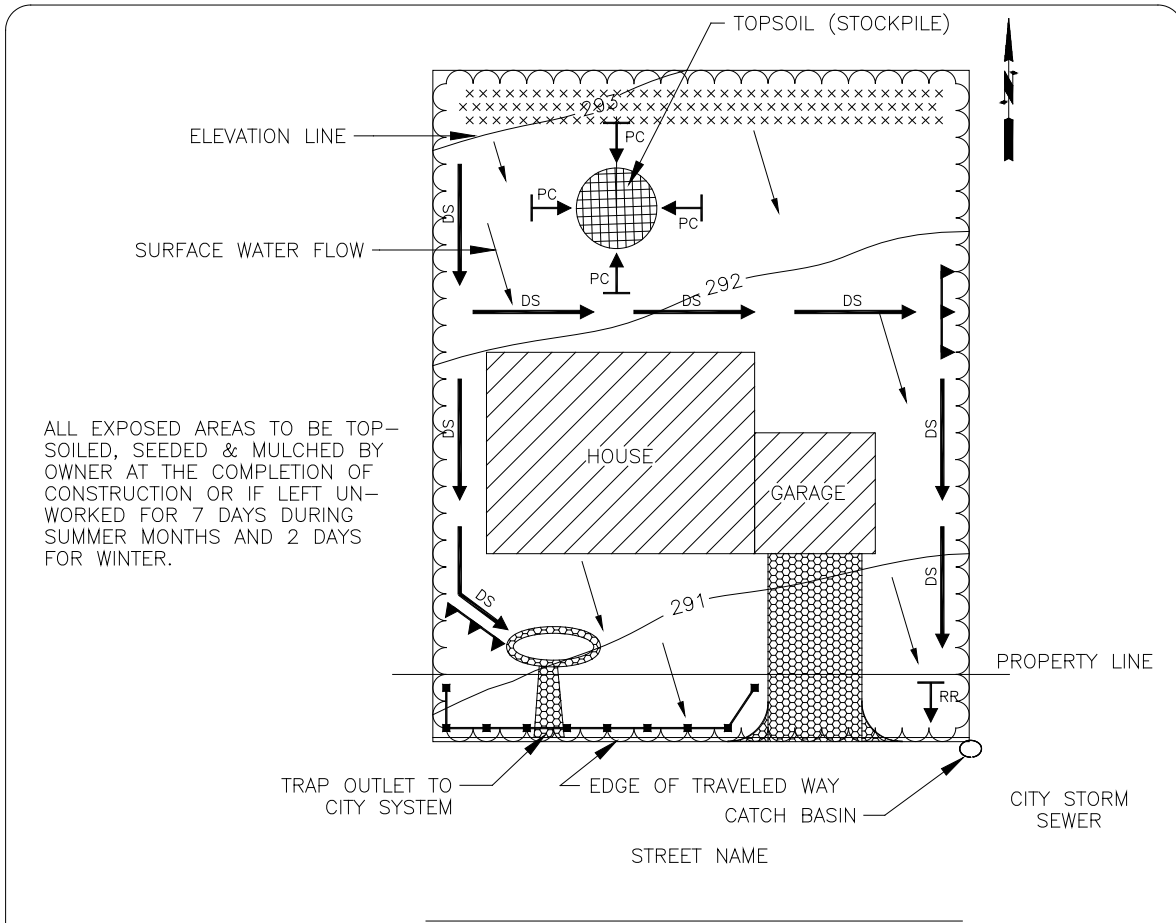
## II. Site Plan (See attached example)

A site plan, to scale, shall be included with this checklist that shows the following items:

- a. Address, Parcel # and Street names\*
- b. North Arrow
- c. Indicate boundaries of existing vegetation, (e.g. tree lines, grassy areas, pasture areas, fields, etc.)\*
- d. Identify any on-site or adjacent critical areas and associated buffers (e.g. wetlands, steep slopes, streams, etc.).
- f. Identify any FEMA base flood boundaries and Shoreline Management boundaries. \*
- g. Show existing and proposed contours. \*
- h. Delineate areas that are to be cleared and graded.
- i. Show all cut and fill slopes indicating top and bottom of slope catch lines
- j. Indicate existing surface water flow direction(s).
- k. Label final grade contours and indicate proposed surface water flow direction and surface water conveyance systems (e.g. pipes, catch basins, ditches, etc.) .
- l. Show grades, dimensions, and direction of flow in all (existing and proposed) ditches, swales, culverts and pipes.
- n. Indicate locations and outlets of any dewatering systems (usually to sediment trap).
- o. Identify and locate all erosion control techniques to be used during and after construction.












See attached: **Guidelines for Erosion Control Practices and sample Site Plan.**

\* This information is available on the City of Tacoma GIS at <http://www.govme.cityoftacoma.org>.  
**Onsite field verification of actual conditions is required.**



ALL EXPOSED AREAS TO BE TOP-SOILED, SEEDED & MULCHED BY OWNER AT THE COMPLETION OF CONSTRUCTION OR IF LEFT UNWORKED FOR 7 DAYS DURING SUMMER MONTHS AND 2 DAYS FOR WINTER.

EROSION CONTROL SYMBOLS

-  SILT FENCE
-  CLEARING & GRADING LIMITS
-  CONSTRUCTION ENTRANCE
-  BERM BARRIER
-  CATCH BASIN PROTECTION
-  SEDIMENT TRAP
-  DRAINAGE SWALE
-  EROSION CONTROL BLANKET/MAT
-  RIP RAP
-  PLASTIC COVERING
-  MULCHES/SEEDING/HYDROSEEDING

NOTE

1. THESE ARE MINIMUM REQUIREMENTS. ADJUST EROSION CONTROL PRACTICES AND MAINTAIN AS CONDITIONS REQUIRE.
2. EROSION AND SEDIMENT CONTROL SHALL BE IN PLACE BEFORE INITIATING ANY CONSTRUCTION ACTIVITIES. AN INSPECTION MUST BE MADE AFTER INSTALLATION OF EROSION CONTROL PRACTICES.

**SINGLE FAMILY LOT/SMALL SITE  
FOR SITES OF ONE ACRE OR LESS**

NOT TO SCALE

**SAMPLE EROSION &  
SEDIMENT CONTROL PLAN**

CITY OF TACOMA  
NOV 2002

Nov 4, 2002-c:\projects\storm\small site erosion control.dwg



## Guidelines for Erosion Control Practices

**As required by Ecology, this SWPPP must contain the 12 required elements. Check off each element as it is addressed in the SWPPP Short Form and/or on your site plan.**

- 1. Mark Clearing Limits (orange construction fence, staking with ribbon).
- 2. Establish Construction Access (gravel entrance, tire wash area).
- 3. Control Flow Rates (using pipe, drainage swales, berms).
- 4. Install Sediment Controls (silt fence, sediment traps).
- 5. Stabilize Soils (mulch, hydroseed, straw).
- 6. Protect Slopes (divert water from top of slope, cover with plastic or erosion control blanket).
- 7. Protect Drain Inlets (catch basin inserts).
- 8. Stabilize Channels and Outlets (cover with grass, riprap).
- 9. Control Pollutants (maintain equipment to prevent leaks)
- 10. Control De-Watering (pump to sediment trap).
- 11. Maintain BMPs (weekly maintenance/replacement, preparation for storm events)
- 12. Manage the Project (establish construction schedule, phasing, contact numbers).

Several common erosion control techniques are explained and described in this section. Standard details for installation of these methods are included in this document. The applicant does not need to reproduce these drawings, but must indicate where they'll be used on a site plan. An example site plan and symbols list is provided to assist the applicant in preparation of their own site plan.

There are a number of different types of erosion control methods that are not discussed in this document. If the applicant chooses to use an erosion control method not listed, they must attach details for installation and describe the maintenance activities associated with the alternative methods.

For phased construction plans, clearly indicate erosion control methods to be used for each phase of construction.

### A. Construction Entrance

All construction projects subject to vehicular traffic shall provide a means of preventing vehicle "tracking" of soil from the site onto City streets. At a minimum, there shall be a rock pad construction entrance at every construction access point. *Note: The applicant should consider placing the entrance in the area for future driveway(s), as the rock can be used for driveway base material.* The entrance(s) shall be inspected weekly and if excessive sediment is found, more rock shall be added to ensure proper functioning.

If sediment is tracked off site, it shall be swept or shoveled from the paved surface on a daily basis. Washing of the streets to remove the sediment is not permitted because wash water can transport sediments to streams and other water courses via the City storm drainage system.

This entrance must be identified on the site plan and must conform to attached Detail 1.

## **B. Sediment Barriers (Details 2 through 6)**

Sediment barriers should be used downslope of disturbed areas. Sediment barriers are intended to create a barrier to slow the “sheet” flow of storm water and allow the sediment to settle out behind the barrier. Do not use sediment barriers in streams, channels, ditches or around inlets/outlets of culverts. Sediment barriers selected shall be identified on the site plan and must conform to the attached details 2 through 6.

### **1. Silt fence**

A silt fence is a temporary sediment barrier consisting of filter fabric, attached to supporting posts and entrenched into the soil. See Detail 2.

### **2. Berm Barriers**

A continuous berm is a temporary diversion dike or sediment barrier. It may be constructed with:

- i. Soil, sand or aggregate encased within a geosynthetic fabric. (Detail 3 & 4)
- ii. Straw wattles (Detail 5)
- iii. Sand bags (Detail 6)

## **C. Catch Basin Protection (Detail 7 & 8)**

To prevent sediment from entering drainage systems prior to site stabilization, catch basin protection shall be installed within onsite and nearby downstream catch basins. Details 7 and 8 are acceptable methods of catch basin protection. Note: Only Detail 7 is approved for use in City of Tacoma streets.

## **D. Water Runoff Containment/Control**

As an alternative or in conjunction with sediment barriers, a combination of drainage swales and possibly a sediment trap may be used to control runoff and trap sediment before it leaves the construction site.

### **1. Sediment traps (Detail 9 & 10)**

Sediment traps are small temporary ponds (typically less than 3 feet deep) used to trap sediment suspended in site runoff before it leaves a construction site. As concentrated surface water pools within the pond, sediment is allowed to settle out of the water. Typically, for small sites a sediment trap will not be required as long as concentrated stormwater runoff (swales or ditches) does not occur.

Note: If dewatering or significant stormwater runoff is expected, a sediment trap should be used to settle out solids before discharge to the City system. See Details 9 and 10.

### **2. Drainage Swales (Detail 11)**

Drainage swales are temporary ditches (min slope of 0.5% and a maximum of 10%) used to convey concentrated storm water flows away from construction activities into a temporary sediment trap. Swales should be stabilized with erosion protection see below. *Note: Swales should be completely stabilized before directing concentrated flows or they themselves will erode.* See Detail 11.

## **E. Soil Erosion Protection**

Soil erosion protection is applied over the soil surface to reduce erosion from rainfall and wind. It can also be used to aid the establishment of vegetation. Between October 1<sup>st</sup> through April 30<sup>th</sup>, no soils shall remain exposed for more than 2 days unless they are being actively worked. From April 1<sup>st</sup> to September 30<sup>th</sup>, no soils shall remain exposed for more than 7 days unless they are being actively worked. See Details 12-16.

### **1. Mulches/Seeding/Hydroseeding (Detail 12)**

Mulching is the application of a protective layer of straw or other suitable material to the soil surface. Mulch can be applied to any site where soil has been disturbed and the protective vegetation has been removed. Materials that may be used for mulching include:

- Straw or hay
- Compost material
- Wood or bark chips
- Hydraulically applied grass seed (aka Hydroseed)
- Bonded Fiber Matrix

*Note: The applicant may wish to mix in grass seed with the above practices to further aid in soil stabilization. Please refer to the attached detail 12.*

### **2. Erosion Control Blankets/ Mats (Detail 13)**

Erosion control blankets are suited for post-construction site stabilization, but may be used for temporary stabilization of highly erosive soils. Erosion control blankets are suitable for steep slopes, stream banks and where vegetation will be slow to establish. These blankets are typically made from straw, coconut fiber, excelsior or synthetic material that is enveloped in plastic, biodegradable netting, jute, polypropylene, and nylon. See detail 13.

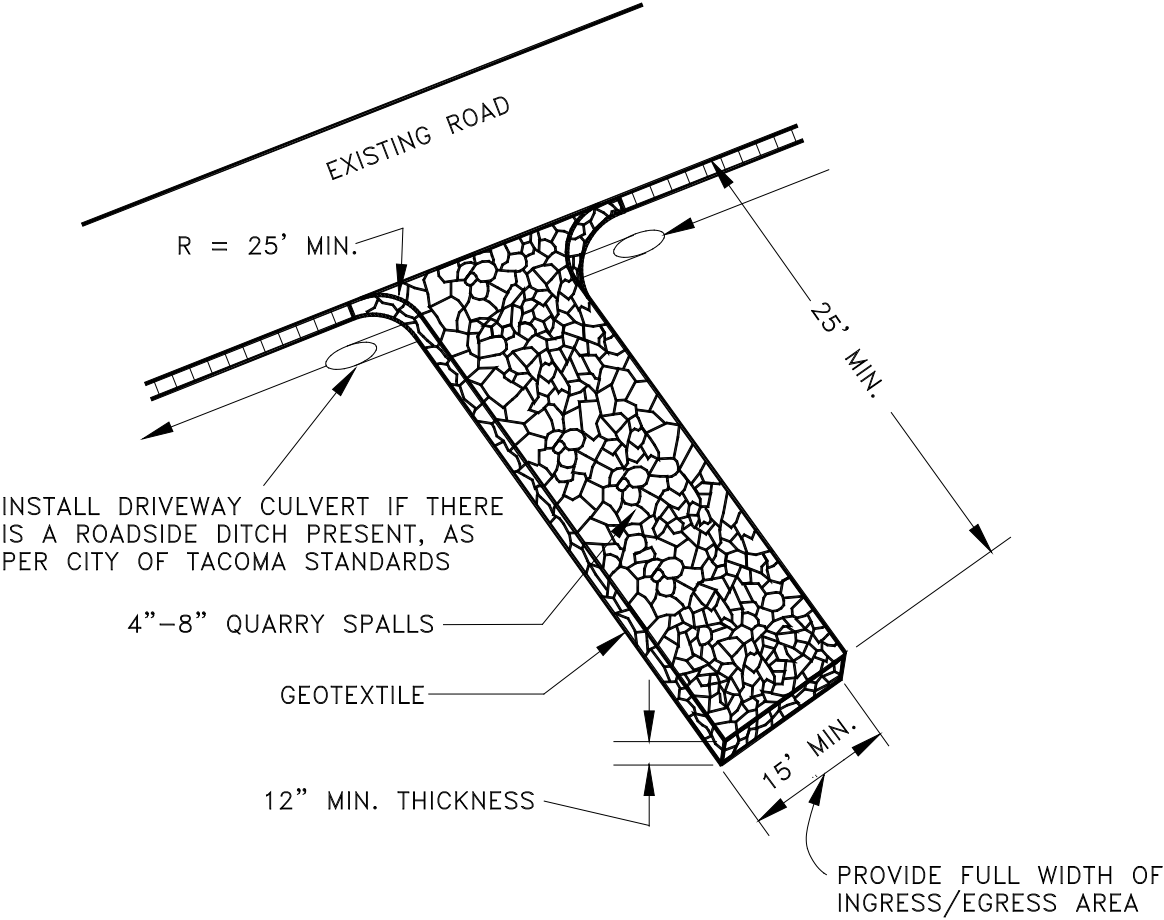
### **3. Gravel/Riprap (Detail 14 & 15)**

Gravel and Riprap are used to protect hillsides, drainage channels, stream banks, and pipe outlets from erosion due to surface water flow. See details 14 and 15.

### **4. Plastic Sheeting (Detail 16)**

Plastic sheeting is a temporary method of erosion control. Plastic covering provides immediate, short-term erosion protection to slopes, soil stockpiles and other disturbed areas. Unlike the other erosion protection techniques mentioned above, plastic sheeting shall be removed prior to applying permanent erosion protection. See detail 16.

IT IS RECOMMENDED THAT THE ENTRANCE BE CROWNED SO THAT RUNOFF DRAINS OFF THE PAD



**ENTRANCE ROCK PAD**

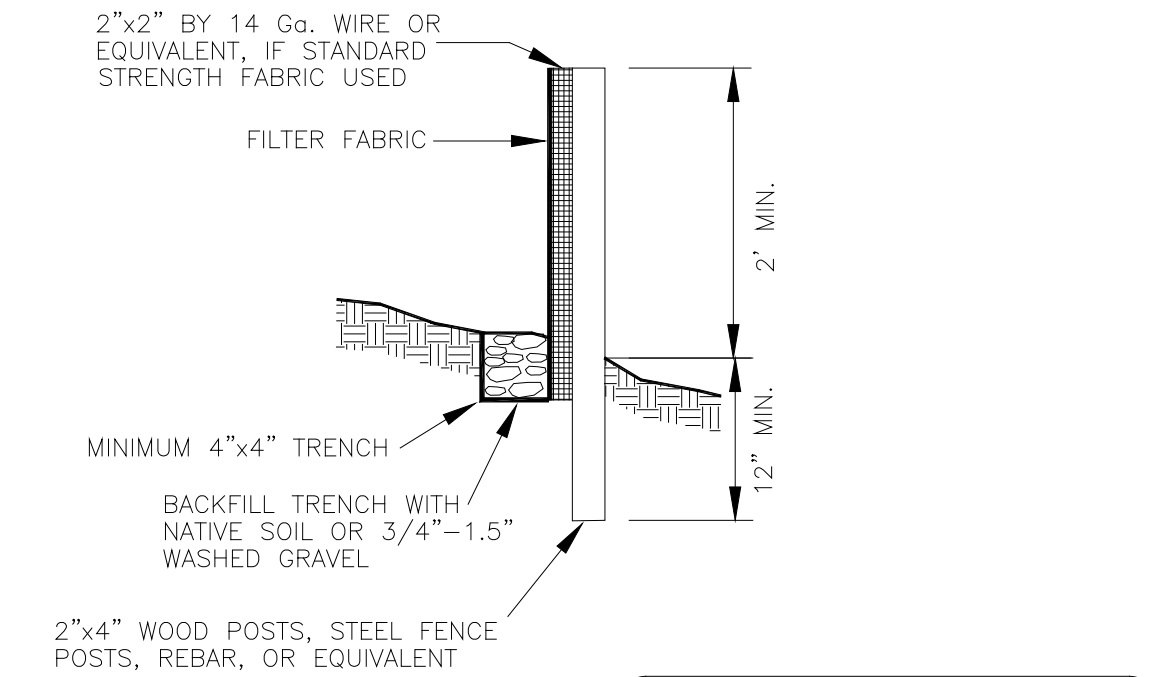
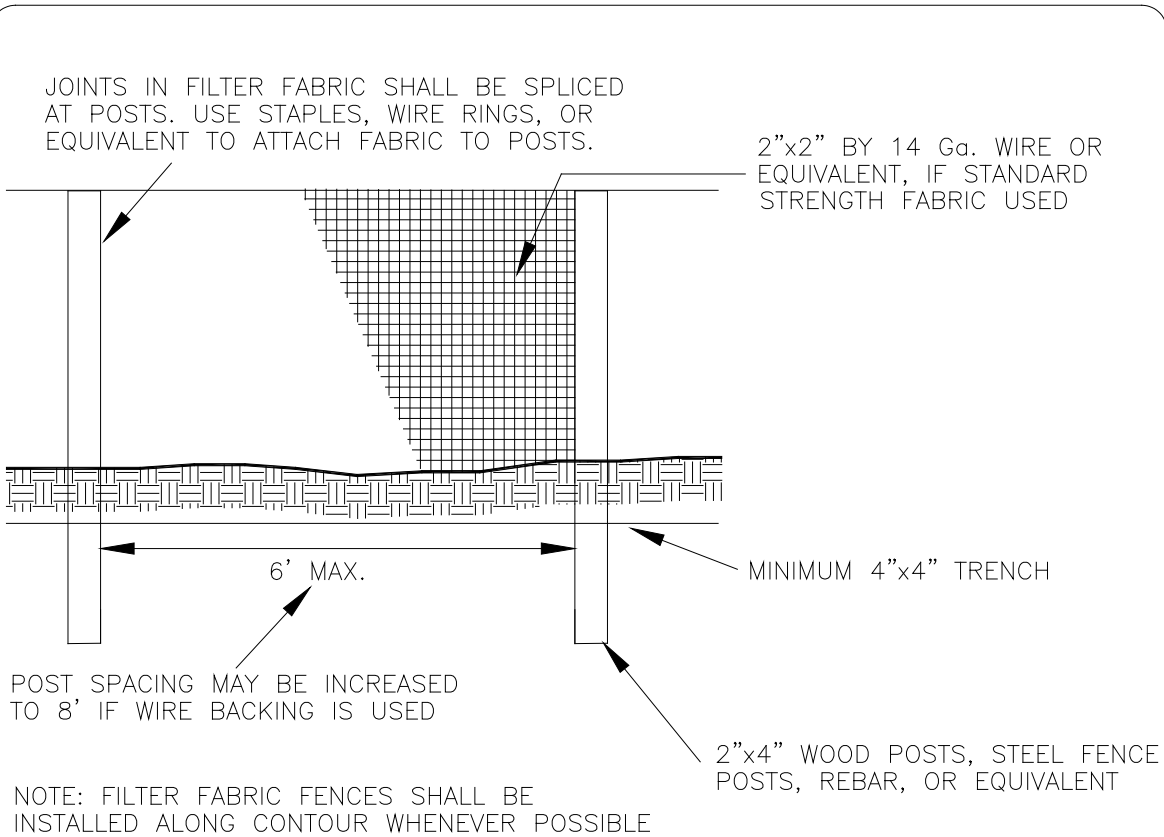
NOT TO SCALE

**CONSTRUCTION SWPPP SHORT-FORM  
CONSTRUCTION ENTRANCE**

CITY OF TACOMA  
NOV 2002

**DETAIL 1**

Nov 4, 2002 c:\projects\storm\small site erosion control.dwg



**SILT FENCE**

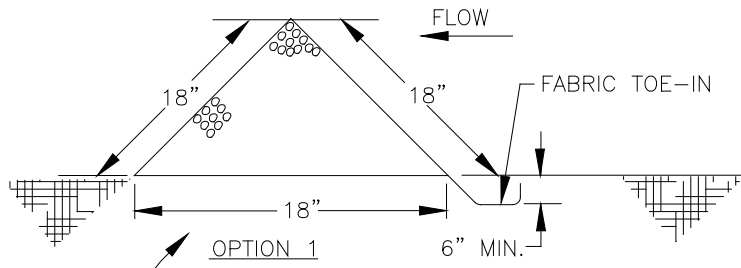
NOT TO SCALE

CONSTRUCTION SWPPP SHORT-FORM  
 SEDIMENT BARRIER

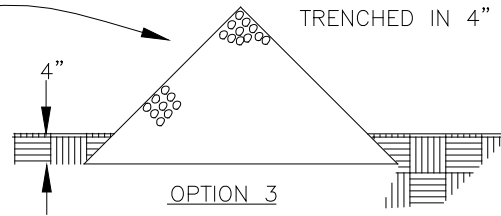
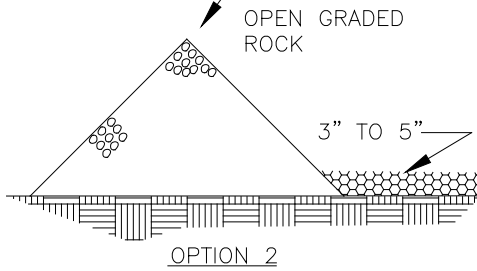
CITY OF TACOMA  
 NOV 2002

**DETAIL 2**

Nov 4, 2002-c:\projects\tacom\small site erosion control.dwg

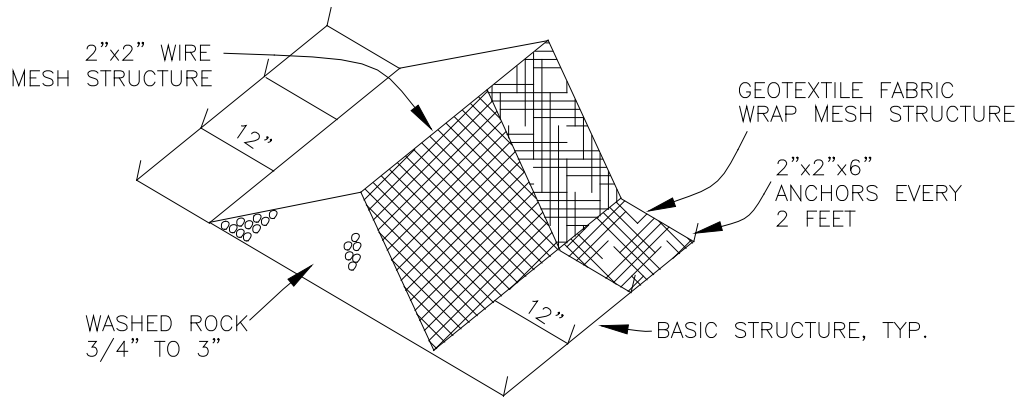


WIRE MESH AND FABRIC STRUCTURES FILLED WITH WASHED ROCK



INSTALLATION DETAIL

- OPTIONS
- 1) TOE-IN 6" MIN.
  - 2) WEIGHTED WITH 3"-5" OPEN GRADED ROCK
  - 3) TRENCHED IN 4"



**TRIANGULAR SEDIMENT  
FILTER DIKES**

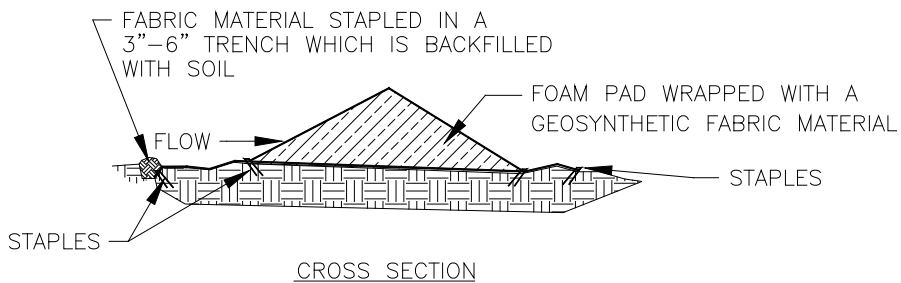
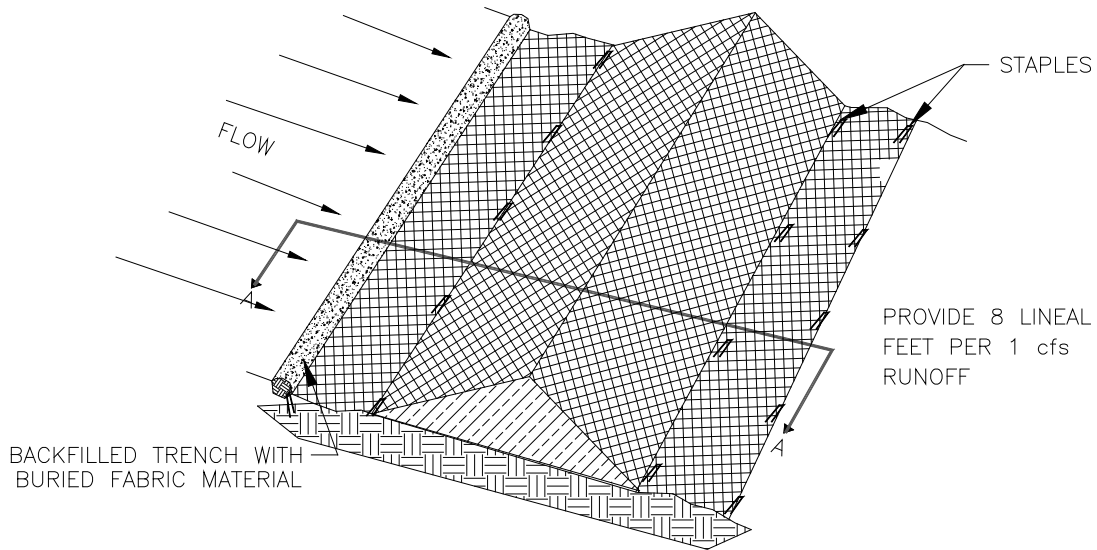
NOT TO SCALE

**CONSTRUCTION SWPPP SHORT-FORM  
SEDIMENT BARRIER**

CITY OF TACOMA  
NOV 2002

**DETAIL 3**

Nov 4, 2002 c:\projects\tacom\small site erosion control.dwg



## GEOSYNTHETIC DIKE

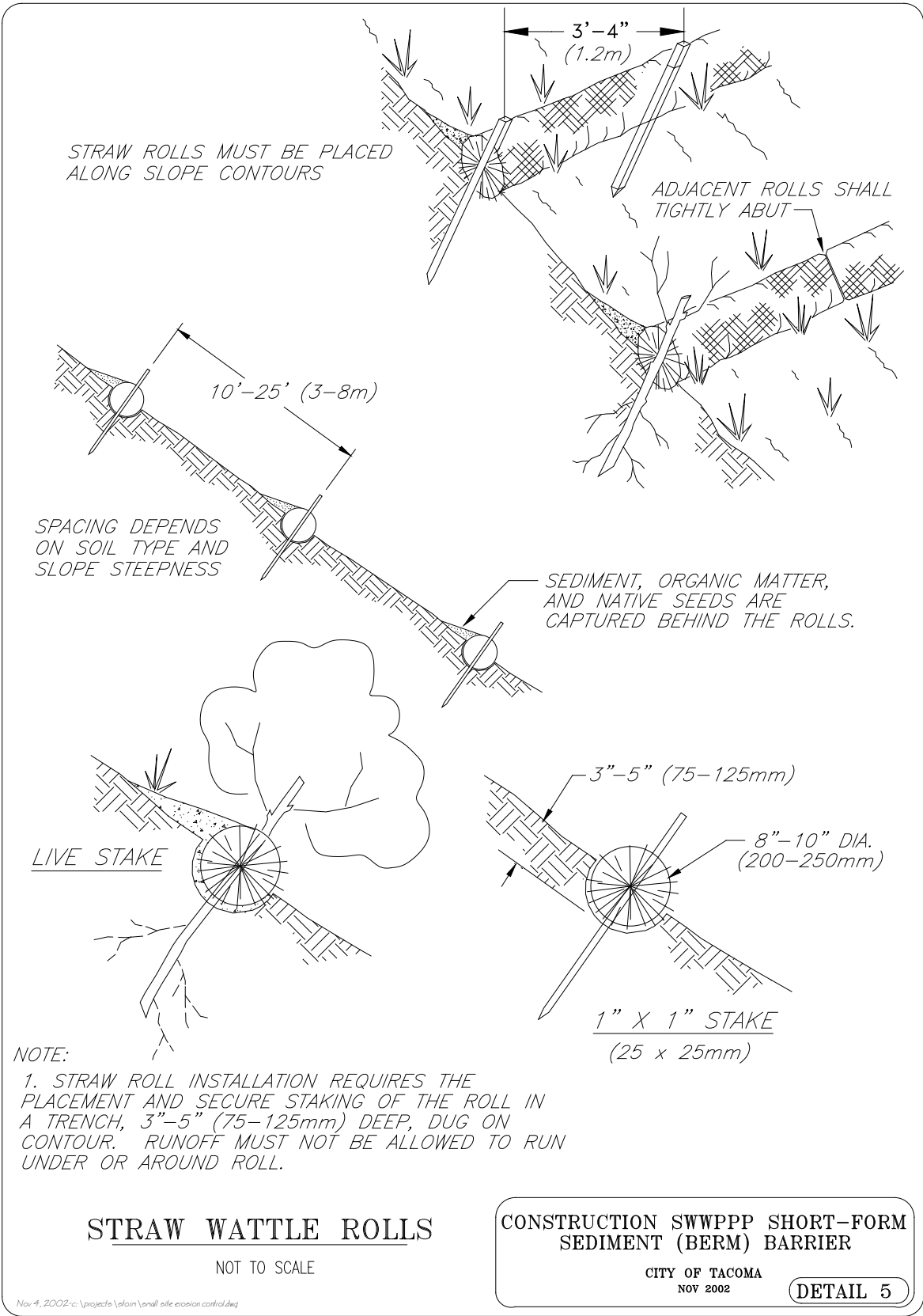
NOT TO SCALE

CONSTRUCTION SWPPP SHORT-FORM  
SEDIMENT BARRIER

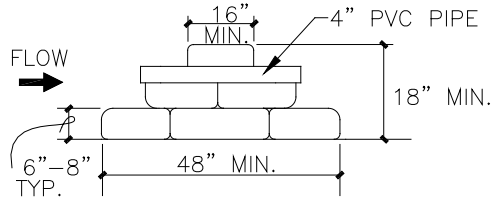
CITY OF TACOMA  
NOV 2002

DETAIL 4

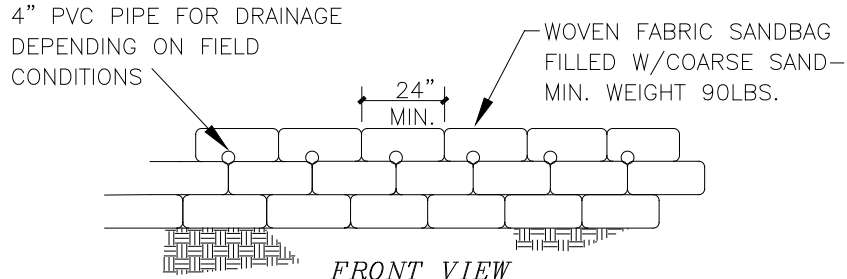
Nov 9, 2002 c:\projects\tacom\small site erosion control.dwg







CROSS SECTION



FRONT VIEW

- 1) WHEN SANDBAG IS FILLED WITH COARSE GRADE SAND MATERIAL, THE OPEN END SHOULD BE STAPLED OR TIED WITH NYLON OR POLY CORD. THE WEIGHT SHALL BE 90 - 125 LBS.
- 2) SANDBAGS SHOULD BE STACKED IN AT LEAST THREE VERTICAL ROWS ABUTTING EACH OTHER, AND IN STAGGERED ARRANGEMENT. (REFER TO FRONT VIEW).
- 3) THE BASE OF THE BERM SHOULD BE AT LEAST 3 SANDBAGS DEEP AND CAN BE REDUCED TO 2 AND 1 BAG IN THE SECOND AND THIRD ROWS RESPECTIVELY. (REFER TO CROSS SECTION).

## SANDBAG BERM

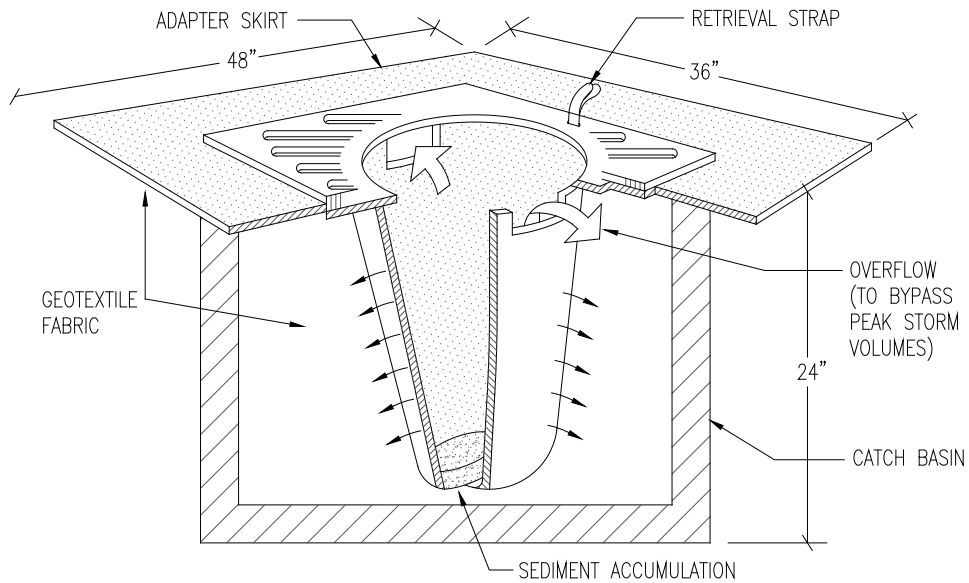
NOT TO SCALE

CONSTRUCTION SWWPPP SHORT-FORM  
SEDIMENT (BERM) BARRIER

CITY OF TACOMA  
NOV 2002

DETAIL 6

Nov 4, 2002-c:\projects\tacoma\small site erosion control.dwg



*INLET PROTECTION NOTES:*

1. FILTERS SHALL BE REMOVED AND CLEANED OR REPLACED AFTER EACH STORM EVENT.

**BAG FILTER**

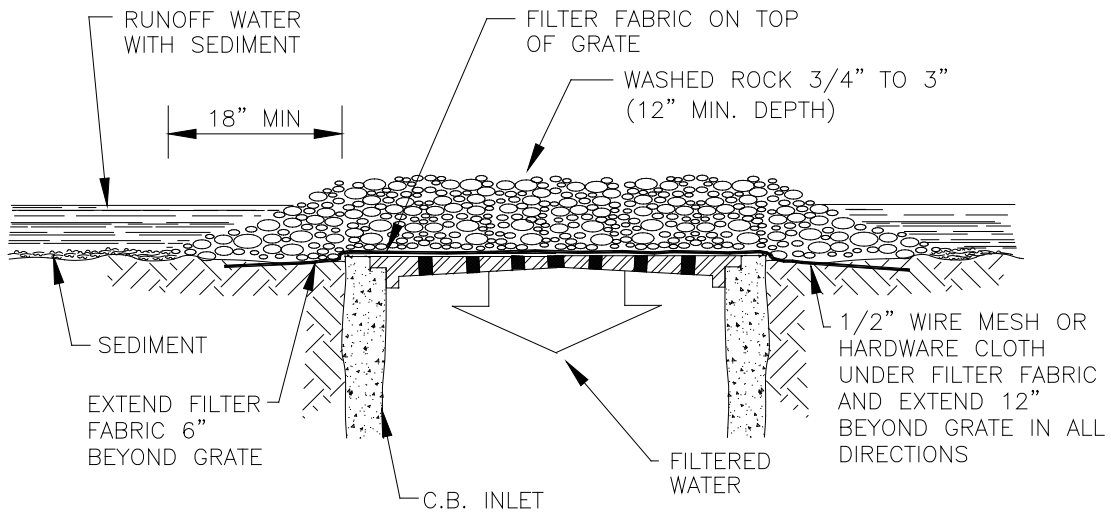
NOT TO SCALE

CONSTRUCTION SWPPP SHORT-FORM  
CATCH BASIN PROTECTION

CITY OF TACOMA  
NOV 2002

**DETAIL 7**

Nov 4, 2002-c:\projects\storm\small site erosion control.dwg



WARNING: DO NOT USE IN STREET OR R.O.W.

**INLET GRAVEL & FILTER FABRIC**

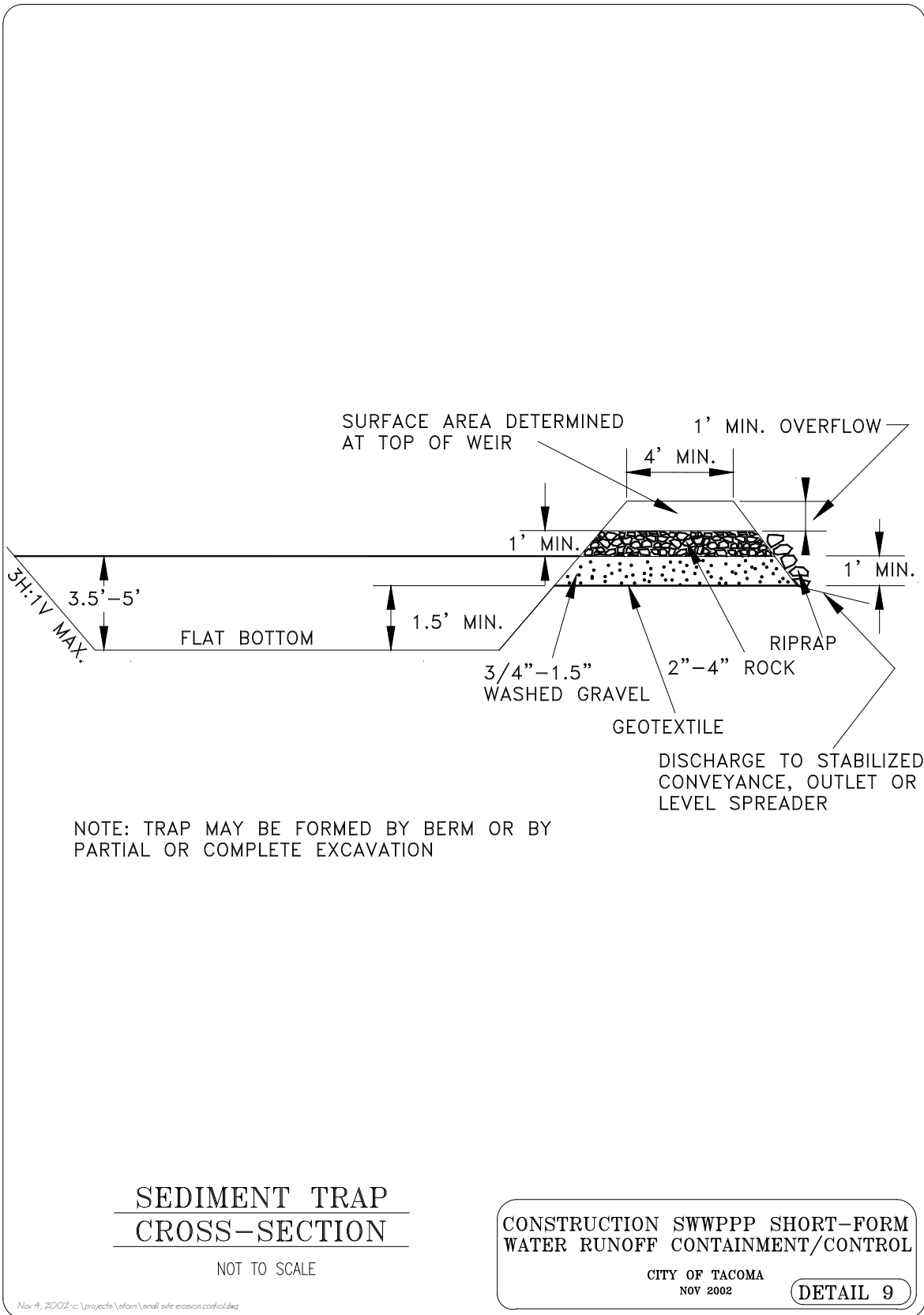
NOT TO SCALE

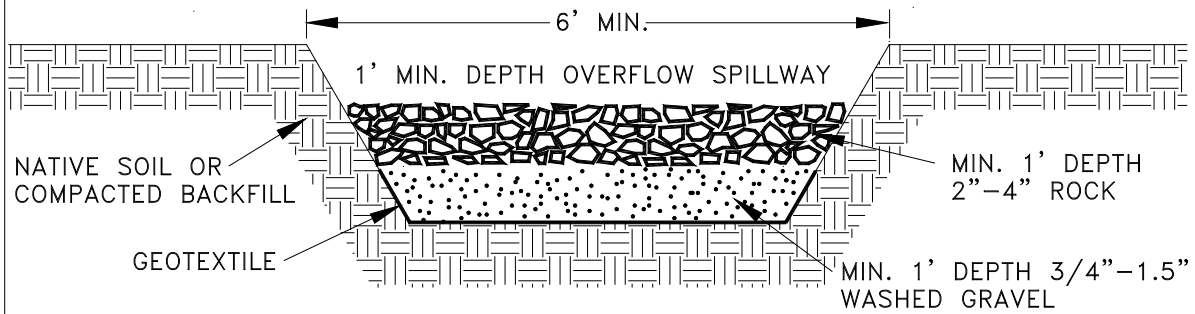
Nov 4, 2002 c:\projects\tacoma\small site erosion control.dwg

**CONSTRUCTION SWPPP SHORT-FORM  
CATCH BASIN PROTECTION**

CITY OF TACOMA  
NOV 2002

**DETAIL 8**





**SEDIMENT TRAP OUTLET**

NOT TO SCALE

**CONSTRUCTION SWPPP SHORT-FORM  
WATER RUNOFF CONTAINMENT/CONTROL**

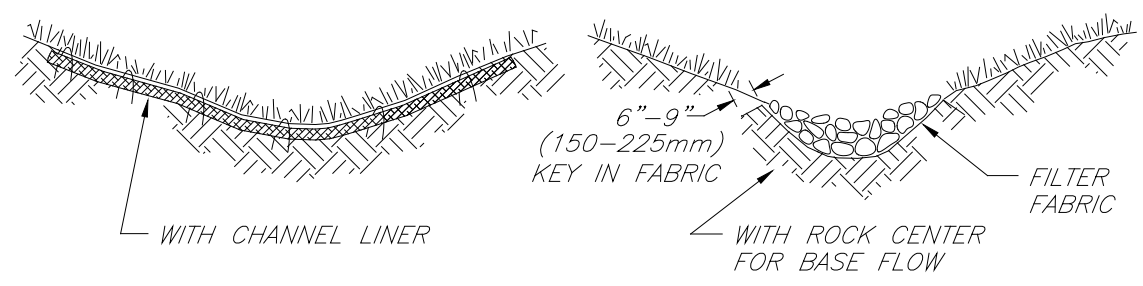
CITY OF TACOMA  
NOV 2002

**DETAIL 10**

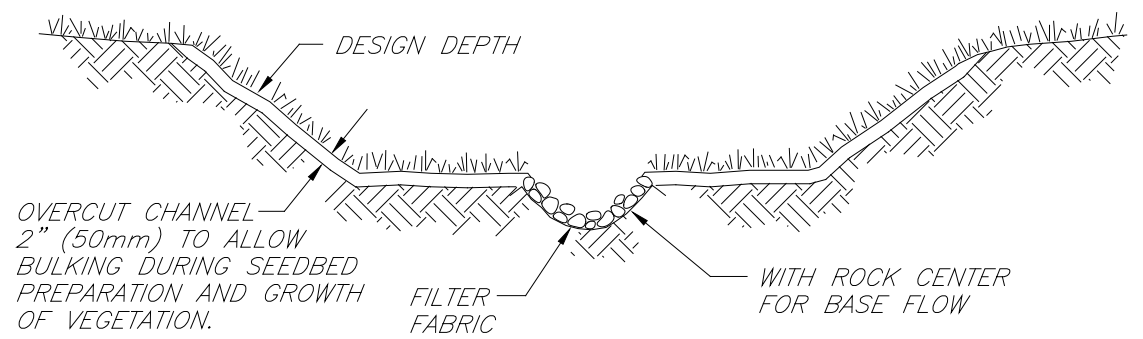
Nov 4, 2002:c:\projects\storm\small site erosion control.dwg

Temporary Erosion Control Seed Mix			
	% Weight	% Purity	% Germination
Chewings of annual blue grass <i>Festuca rubra</i> var. <i>commutata</i> or <i>Poa anna</i>	40	98	90
Perennial rye - <i>Lolium perenne</i>	50	98	90
Redtop or colonial bentgrass <i>Agrostis alba</i> or <i>Agrostis tenuis</i>	5	92	85
White dutch clover <i>Trifolium repens</i>	5	98	90

TYPICAL V-SHAPED CHANNEL



TYPICAL PARABOLIC CHANNEL



TYPICAL TRAPEZOIDAL CHANNEL

DRAINAGE SWALE CROSS-SECTIONS

NOT TO SCALE

CONSTRUCTION SWPPP SHORT-FORM  
 WATER RUNOFF CONTAINMENT/CONTROL  
 CITY OF TACOMA  
 NOV 2002  
**DETAIL 11**

Nov 4, 2002-c:\projects\storm\small site erosion control.dwg

Mulch Standards and Guidelines			
Mulch Material	Quality Standards	Application Rates	Remarks
Straw	Air-dried; free from undesirable seed and coarse material.	2"-3" thick; 5 bales per 1000 sf or 2-3 tons per acre	Cost-effective protection when applied with adequate thickness. Hand-application generally requires greater thickness than blown straw. The thickness of straw may be reduced by half when used in conjunction with seeding. In windy areas straw must be held in place by crimping, using a tackifier, or covering with netting. Blown straw always has to be held in place with a tackifier as even light winds will blow it away. Straw, however, has several deficiencies that should be considered when selecting mulch materials. It often introduces and/or encourages the propagation of weed species and it has no significant long-term benefits. Straw should be used only if mulches with long-term benefits are unavailable locally. It should also not be used within the ordinary high-water elevation of surface waters (due to flotation).
Hydromulch	No growth inhibiting factors.	Approx. 25-30 lbs per 1000 sf or 1500 - 2000 lbs per acre	Shall be applied with hydromulcher. Shall not be used without seed and tackifier unless the application rate is at least doubled. Fibers longer than about ¾-1 inch clog hydromulch equipment. Fibers should be kept to less than ¼ inch.
Composted Mulch and Compost	No visible water or dust during handling. Must be purchased from supplier with Solid Waste Handling Permit (unless exempt).	2" thick min.; approx. 100 tons per acre (approx. 800 lbs per yard)	More effective control can be obtained by increasing thickness to 3". Excellent mulch for protecting final grades until landscaping because it can be directly seeded or tilled into soil as an amendment. Composted mulch has a coarser size gradation than compost. It is more stable and practical to use in wet areas and during rainy weather conditions.
Chipped Site Vegetation	Average size shall be several inches. Gradations from fines to 6 inches in length for texture, variation, and interlocking properties.	2" minimum thickness	This is a cost-effective way to dispose of debris from clearing and grubbing, and it eliminates the problems associated with burning. Generally, it should not be used on slopes above approx. 10% because of its tendency to be transported by runoff. It is not recommended within 200 feet of surface waters. If seeding is expected shortly after mulch, the decomposition of the chipped vegetation may tie up nutrients important to grass establishment.
Wood-based Mulch	No visible water or dust during handling. Must be purchased from a supplier with a Solid Waste Handling Permit or one exempt from solid waste regulations.	2" thick; approx. 100 tons per acre (approx. 800 lbs. per cubic yard)	This material is often called "hog or hogged fuel." It is usable as a material for Stabilized Construction Entrances (BMP C105) and as a mulch. The use of mulch ultimately improves the organic matter in the soil. Special caution is advised regarding the source and composition of wood-based mulches. Its preparation typically does not provide any weed seed control, so evidence of residual vegetation in its composition or known inclusion of weed plants or seeds should be monitored and prevented (or minimized).

## HYDROSEED & MULCH SPECIFICATIONS

NOT TO SCALE

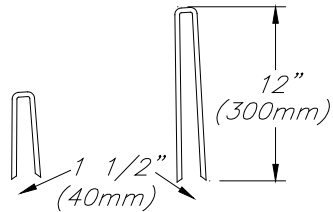
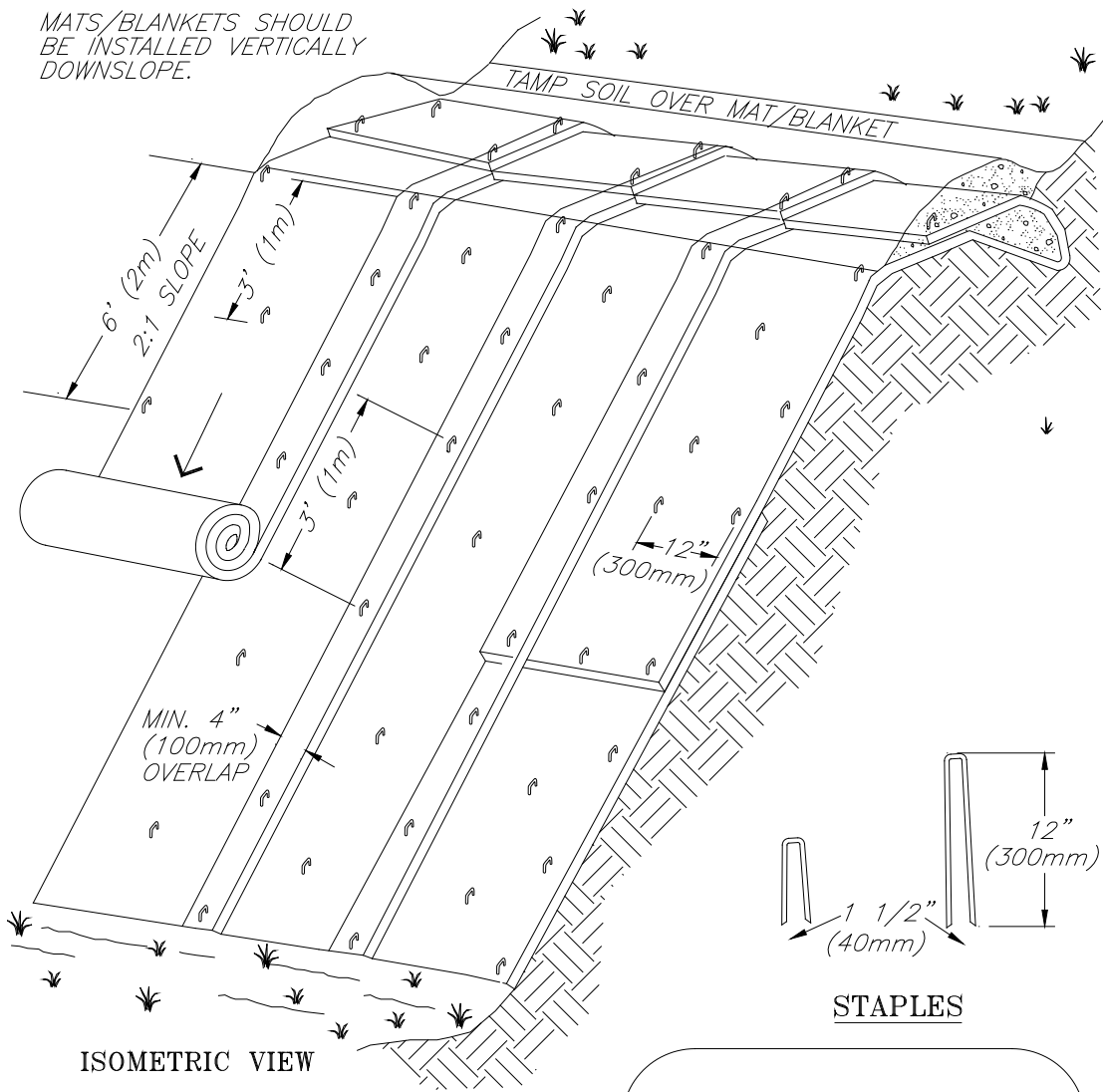
CONSTRUCTION SWWPPP SHORT-FORM  
SOIL EROSION PROTECTION

CITY OF TACOMA  
NOV 2002

DETAIL 12

Nov 4, 2002-c:\projects\storm\small site erosion control.dwg

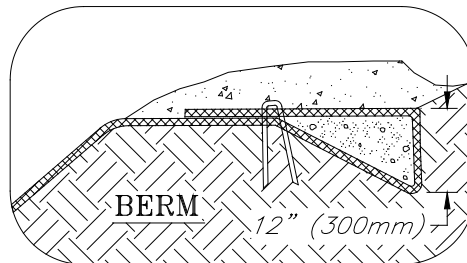
MATS/BLANKETS SHOULD BE INSTALLED VERTICALLY DOWNSLOPE.



**STAPLES**

**NOTES:**

1. SLOPE SURFACE SHALL BE FREE OF ROCKS, CLODS, STICKS AND GRASS. MATS/BLANKETS SHALL HAVE GOOD SOIL CONTACT.
2. APPLY PERMANENT SEEDING BEFORE PLACING BLANKETS.
3. LAY BLANKETS LOOSELY AND STAKE OR STAPLE TO MAINTAIN DIRECT CONTACT WITH THE SOIL. DO NOT STRETCH.



**EROSION BLANKETS & TURF REINFORCEMENT MATS**

NOT TO SCALE

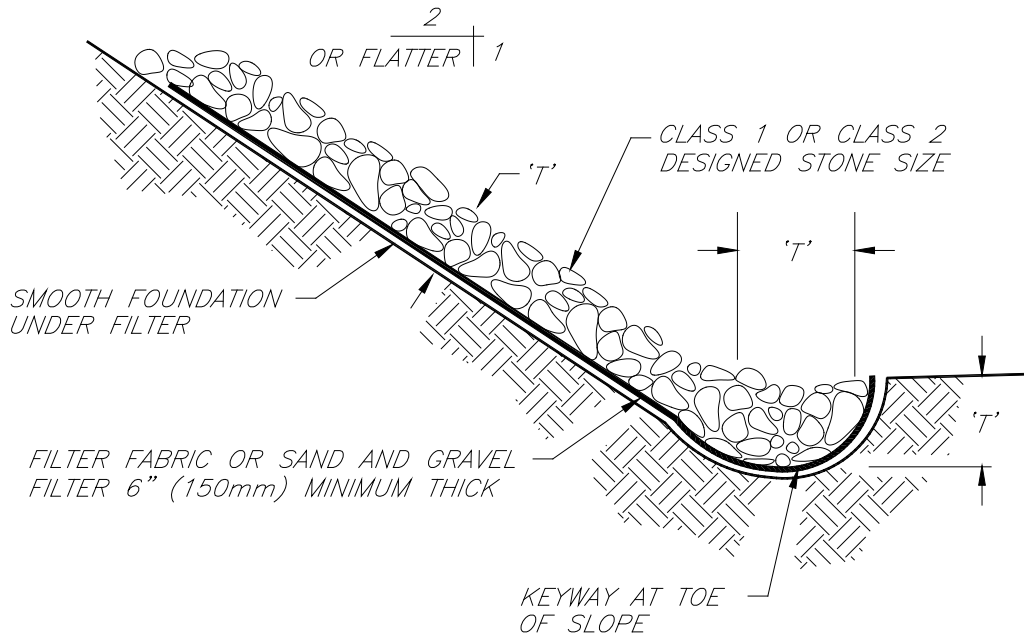
CONSTRUCTION SWPPP SHORT-FORM SOIL EROSION PROTECTION

CITY OF TACOMA  
NOV 2002

**DETAIL 13**

Nov 4, 2002-c:\projects\tacom\small site erosion control.dwg





**TYPICAL SECTION**

**NOTE:**

'T' = THICKNESS: THICKNESS SHALL BE DETERMINED BY THE ENGINEER.

MINIMUM THICKNESS SHALL BE 1.5x THE MAXIMUM STONE DIAMETER, NEVER LESS THAN 6" (150mm).

**RIP RAP PROTECTION**

NOT TO SCALE

**CONSTRUCTION SWPPP SHORT-FORM  
SOIL EROSION PROTECTION**

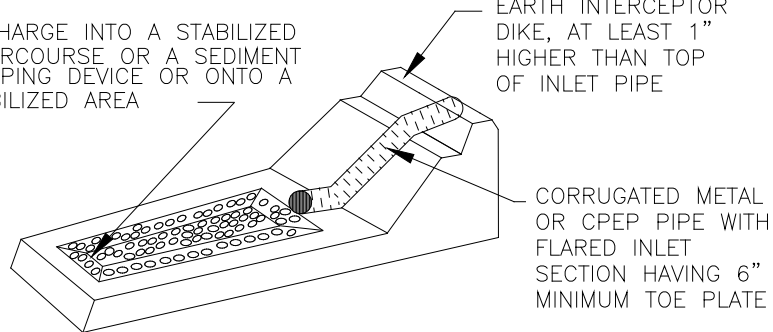
CITY OF TACOMA  
NOV 2002

**DETAIL 14**

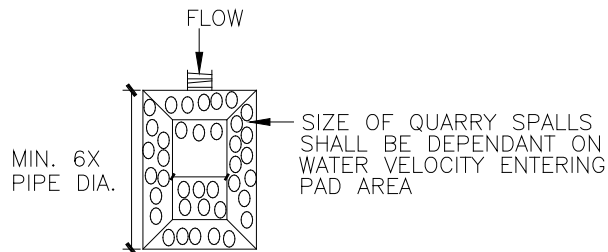
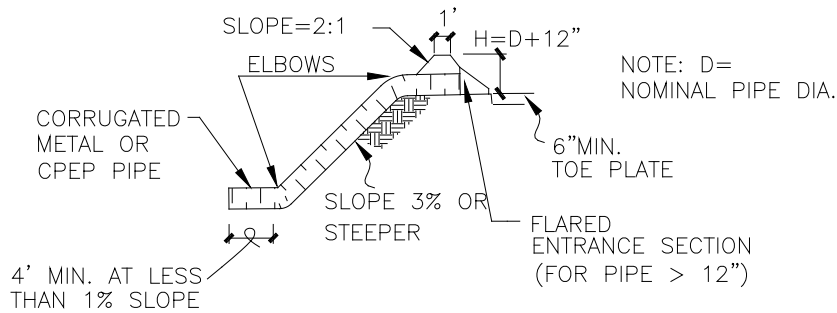
Nov 4, 2002:c:\projects\tcfam\small site erosion control.dwg

DISCHARGE INTO A STABILIZED WATERCOURSE OR A SEDIMENT TRAPPING DEVICE OR ONTO A STABILIZED AREA

EARTH INTERCEPTOR DIKE, AT LEAST 1" HIGHER THAN TOP OF INLET PIPE



CORRUGATED METAL OR CPEP PIPE WITH FLARED INLET SECTION HAVING 6" MINIMUM TOE PLATE



DEPTH OF APRON RIP-RAP SHALL BE EQUAL TO PIPE DIAMETER AT A MINIMUM

## PIPE SLOP DRAINS

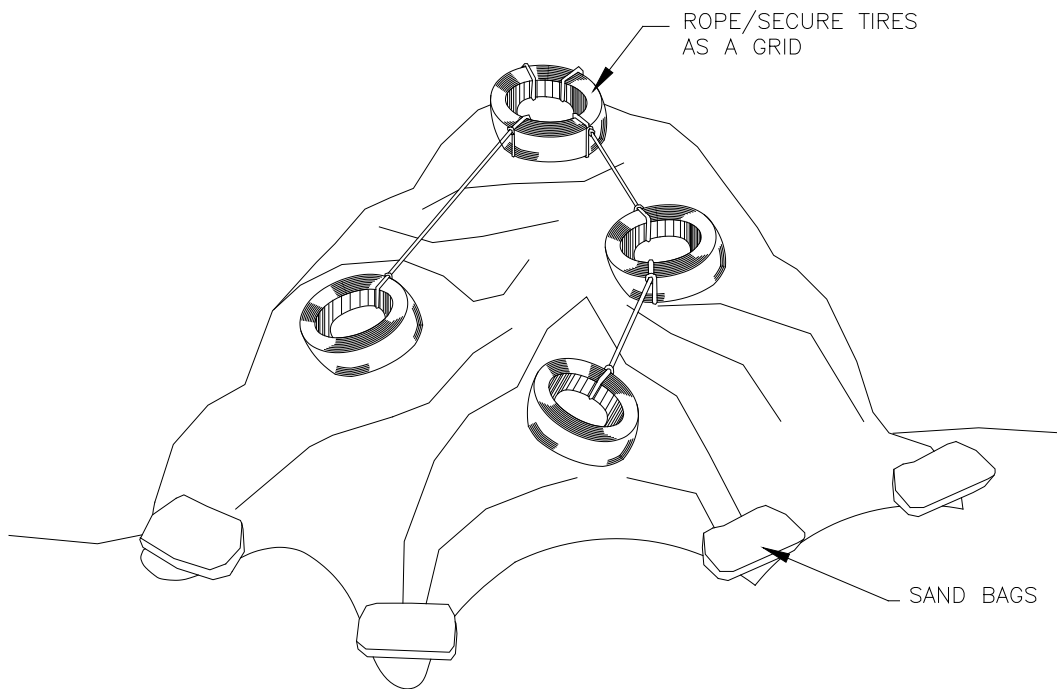
NOT TO SCALE

CONSTRUCTION SWPPP SHORT-FORM  
SOIL EROSION PROTECTION

CITY OF TACOMA  
NOV 2002

DETAIL 15

Nov 4, 2002 c:\projects\tacoma\small site erosion control.dwg



NOTE: USE OLD TIRES OR SAND BAGS  
TO ANCHOR PLASTIC COVERING.

## TARP COVERING

NOT TO SCALE

CONSTRUCTION SWPPP SHORT-FORM  
SOIL EROSION PROTECTION

CITY OF TACOMA  
NOV 2002

DETAIL 16

Nov 4, 2002-c:\projects\storm\small site erosion control.dwg

# **City of Tacoma Surface Water Management Manual**

---

## **Volume III Hydrologic Analysis and Flow Control Design/BMPs**

Prepared by:

Tacoma Public Works  
Environmental Services

January 2003



# Table of Contents – Volume III

---

<b>Chapter 1 – Introduction</b> .....	<b>1-1</b>
1.1 Purpose of this Volume.....	1-1
1.2 Content and Organization of this Volume.....	1-1
1.3 How to Use this Volume.....	1-2
<b>Chapter 2 – Hydrologic Analysis</b> .....	<b>2-1</b>
2.1 Minimum Computational Standards .....	2-1
2.1.1 Discussion of Hydrologic Analysis Methods Used for Designing BMPs.....	2-3
2.2 Western Washington Hydrology Model .....	2-5
2.3 Single Event Hydrograph Method .....	2-10
2.3.1 Design Storm Hyetograph .....	2-10
2.3.2 Runoff Parameters .....	2-11
2.3.3 Hydrograph Synthesis – Santa Barbara Urban Hydrograph .....	2-18
2.3.4 Hydrograph Routing (Sizing Detention Facilities).....	2-20
2.3.5 Hydrograph Summation and Phasing .....	2-30
2.3.6 Computer Applications .....	2-31
2.4 Closed Depression Analysis .....	2-31
<b>Chapter 3 – Flow Control Design</b> .....	<b>3-1</b>
3.1 Roof Downspout Controls .....	3-1
3.1.1 Downspout Infiltration Systems .....	3-2
3.1.2 Downspout Dispersion Systems.....	3-6
3.1.3 Perforated Stub-Out Connections.....	3-8
3.2 Infiltration Stormwater Quantity and Flow Control .....	3-9
3.2.1 Purpose.....	3-9
3.2.2 Description .....	3-9
3.2.3 Applications.....	3-9
3.2.4 Site Characterization Criteria.....	3-10
3.2.5 Design Infiltration Rate Determination – Guidelines and Criteria .....	3-13
3.2.6 Site Suitability Criteria (SSC).....	3-16
3.2.7 General Design, Maintenance, and Construction Criteria for Infiltration Facilities.....	3-19

3.2.8	Infiltration Basins .....	3-20
3.2.9	Infiltration Trenches .....	3-22
3.3	Detention Facilities.....	3-24
3.3.1	Detention Ponds.....	3-24
3.3.2	Detention Tanks .....	3-35
3.3.3	Detention Vaults .....	3-37
3.3.4	Control Structures .....	3-39
3.3.5	Other Detention Options.....	3-43
<b>Chapter 4 – Conveyance System Design and Hydraulic Analysis .....</b>		<b>4-1</b>
4.1	Purpose .....	4-1
4.2	Required vs. Recommended Design Criteria .....	4-1
4.3	Conveyance Analysis Requirements.....	4-1
4.3.1	On-Site Analysis.....	4-1
4.3.2	Off-Site Analysis (1/4 Downstream Analysis).....	4-2
4.4	Design Event .....	4-2
4.5	Method of Analysis.....	4-3
4.5.1	Rational Method .....	4-4
4.5.2	Minimum Computational Standards (SBUH or Continuous Runoff Model Methods) .....	4-7
4.6	Pipes, Culverts and Open Channels .....	4-7
4.6.1	Pipe Systems .....	4-7
4.6.1.1	Design Flows .....	4-7
4.6.1.2	Conveyance Capacity.....	4-7
4.6.1.3	Pipe Specifications .....	4-10
4.6.2	Culverts.....	4-16
4.6.2.1	Design Flows .....	4-16
4.6.2.2	Conveyance Capacity.....	4-17
4.6.3	Open Channels .....	4-20
4.6.3.1	Design Flows .....	4-21
4.6.3.2	Conveyance Capacity.....	4-22
4.7	Outfalls and Pump Systems.....	4-27
4.7.1	Outfall Systems .....	4-27
4.7.2	Pump Systems .....	4-27

4.8	Easements, Access, and Dedicated Tracts .....	4-28
4.8.1	Stormwater Facilities .....	4-29
4.8.2	Conveyance Systems .....	4-29

**References .....**Ref-1

**Appendices**

Appendix III-A	Isopluvial Maps for Design Storms
Appendix III-B	Western Washington Hydrology Model – Information, Assumptions, and Computation Steps
Appendix III-C	Stormwater Details

**Tables**

Table 2.1	24-Hour Design Storm Hyetograph Values - 10 Minute Resolution .....	2-33
Table 2.2	Hydrologic Soil Series for Selected Soils in Washington State.....	2-37
Table 2.3	Runoff Curve Numbers for Selected Agricultural, Suburban, and Urban Areas.....	2-39
Table 2.4	“n” and “k” Values Used in Time Calculations for Hydrographs .....	2-40
Table 2.5	Values of the Roughness Coefficient, “n” .....	2-41
Table 2.6	SBUH Values for Existing Site Condition .....	2-42
Table 2.7	SBUH Values for Developed Site Condition.....	2-45
Table 2.8	Tabulation of Data for Routing Curve.....	2-48
Table 2.9	Tabular Calculation of Outflow Using Level Pool Routing .....	2-48
Table 2.10	Stage – Storage Table .....	2-49
Table 2.11	Closed Depression Summary Table .....	2-49
Table 3.1	Recommended Infiltration Rates Based on USDA Soil Texture Classification.....	3-44
Table 3.2	Alternative Recommended Infiltration Rates based on ASTM Gradation Testing .....	3-44
Table 3.3	Correction Factors to be Used With In-Situ Infiltration Measurements to Estimate Long-Term Design Infiltration Rates .....	3-44
Table 3.4	Small Trees and Shrubs with Fibrous Roots .....	3-45
Table 3.5	Stormwater Tract "Low Grow" Seed Mix .....	3-45
Table 3.6	Specific Maintenance Requirements for Detention Ponds.....	3-46
Table 3.7	Specific Maintenance Requirements for Detention Vaults/Tanks .....	3-48
Table 3.8	Maintenance of Control Structures and Catchbasins .....	3-49
Table 3.9	Values of $C_d$ for Sutro Weirs.....	3-51
Table 4.1	Percentage Impervious for Modeling Fully Developed Conditions.....	4-31
Table 4.2	Coefficients for the Rational Method .....	4-31
Table 4.3	Runoff Coefficients – “C” Values for the Rational Method .....	4-31
Table 4.4	$k_r$ Values for Derivation of $T_t$ .....	4-32
Table 4.5	Manning’s ‘N’ Values for Pipes .....	4-32
Table 4.6	Maximum Pipe Slopes, Velocities and Anchor Requirements .....	4-33
Table 4.7	Allowable Structures and Pipe Sizes .....	4-33
Table 4.8	Constants for Inlet Control Equations .....	4-34



Table 4.9 Entrance Loss Coefficients .....	4-35
Table 4.10 Channel Protection .....	4-36
Table 4.11 Values of the Roughness Coefficient, “n” .....	4-37
Table 4.12 Minimum Easement Widths for Conveyance Systems For Access, Inspection and Maintenance .....	4-38
Table 4.13 Additional Storm Drain Easement Widths .....	4-38

## Figures

Figure 2-1 Volume Correction Factor to be Applied to Flow Control BMPs Based on Site Impervious Cover .....	2-50
Figure 2-2 24-hour Design Storm Hyetographs .....	2-51
Figure 2-3 SBUH Hydrograph for Existing and Developed Site Conditions .....	2-52
Figure 2-4 Proposed Retention/Detention Facility Site Contours At 1-Foot Intervals .....	2-52
Figure 2-5 Stage Storage Relationship .....	2-53
Figure 2-6 Routing Curve for $\Delta t= 60$ minutes .....	2-53
Figure 2-7 Simplified Example of Inflow Hydrograph .....	2-54
Figure 2-8 Simplified Example of Inflow and Outflow Hydrograph .....	2-54
Figure 2-9 Plots of the Developed Condition Inflow Hydrographs for the 2, 10, and 100-Year Design Storms .....	2-55
Figure 2-10 Stage-Storage Curve .....	2-56
Figure 2-11 Flow Restrictor Schematic .....	2-56
Figure 2-12 Shifting the Hydrographs Using Travel Time .....	2-57
Figure 2-13 Summing the Shifted Hydrographs .....	2-57
Figure 2-14 Hydrograph Phasing Analysis .....	2-58
Figure 2-15 Reducing the Release Rate to Decrease Downstream Effects .....	2-58
Figure 3-1 Typical Downspout Infiltration Trench .....	3-52
Figure 3-2 Alternative Downspout Infiltration Trench System For Coarse Sand And Gravel .....	3-53
Figure 3-3 Typical Downspout Dispersion Trench .....	3-54
Figure 3-4 Standard Dispersion Trench with Notched Grade Board .....	3-55
Figure 3-5 Typical Downspout Splashblock Dispersion .....	3-56
Figure 3-6 Perforated Stub-Out Connection .....	3-57
Figure 3-7 Typical Infiltration Pond/Basin .....	3-58
Figure 3-8 USDA Textural Triangle .....	3-59
Figure 3-9 Schematic of an Infiltration Trench .....	3-60
Figure 3-10 Parking Lot Perimeter Trench Design .....	3-60
Figure 3-11 Median Strip Trench Design .....	3-61
Figure 3-12 Oversized Pipe Trench Design .....	3-61
Figure 3-13 Swale/Trench Design .....	3-62
Figure 3-14 Observation Well Details .....	3-62
Figure 3-15 Typical Detention Pond .....	3-63
Figure 3-16 Typical Detention Pond Sections .....	3-64
Figure 3-17 Overflow Structure .....	3-65
Figure 3-18 Example of Permanent Surface Water Control Pond Sign .....	3-66
Figure 3-19 Weir Section for Emergency Overflow Spillway .....	3-67
Figure 3-20 Typical Detention Tank .....	3-67
Figure 3-21 Detention Tank Access Detail .....	3-68
Figure 3-22 Typical Detention Vault .....	3-69

Figure 3-23	Flow Restrictor (TEE).....	3-70
Figure 3-24	Flow Restrictor (Baffle) .....	3-71
Figure 3-25	Flow Restrictor (Weir) .....	3-72
Figure 3-26	Simple Orifice .....	3-73
Figure 3-27	Rectangular, Sharp-Crested Weir .....	3-73
Figure 3-28	V-Notch, Sharp-Crested Weir .....	3-74
Figure 3-29	Sutro Weir.....	3-74
Figure 3-30	Riser Inflow Curves.....	3-75
Figure 4-1	Nomograph for Sizing Circular Drains Flowing Full .....	4-39
Figure 4-2	Circular Channel Ratios .....	4-40
Figure 4-3	Backwater Calculation Sheet .....	4-41
Figure 4-4	Backwater Calculation Sheet Notes .....	4-42
Figure 4-5	Backwater Pipe Calculation Example.....	4-43
Figure 4-6	Junction Head Loss in Structures.....	4-44
Figure 4-7	Bend Head Loss in Structures .....	4-45
Figure 4-8	Pipe Compaction Designs and Backfill.....	4-46
Figure 4-9	Pipe Anchor Detail .....	4-47
Figure 4-10	Debris Barrier.....	4-48
Figure 4-11	Inlet/Outlet Control Conditions .....	4-49
Figure 4-12	Headwater Depth for Smooth Interior Pipe Culverts with Inlet Control .....	4-50
Figure 4-13	Headwater Depth for Corrugated Pipe Culverts with Inlet Control .....	4-51
Figure 4-14	Head for Culverts (Pipe W/"N" = 0.012) Flowing with Outlet Control .....	4-52
Figure 4-15	Head for Culverts (Pipe W/"N" = 0.024) Flowing with Outlet Control .....	4-53
Figure 4-16	Critical Depth of Flow for Circular Culverts.....	4-54
Figure 4-17	Mean Channel Velocity vs. Medium Stone Weight (W50) and Equivalent Stone Diameter .....	4-55
Figure 4-18	Riprap Gradation Curve .....	4-56
Figure 4-19	Ditches-Common Section .....	4-57
Figure 4-20	Drainage Ditches-Common Sections .....	4-58
Figure 4-21	Geometric Elements of Common Sections.....	4-59
Figure 4-22	Open Channel Flow Profile Computation .....	4-60
Figure 4-23	Direct Step Backwater Method – Example .....	4-61

### **Credit for Figures**

The figures in Chapter 3 are reproduced, with permission, from King County's Surface Water Design Manual.

# Chapter 1 – Introduction

---

## 1.1 Purpose of this Volume

Best Management Practices (BMPs) are schedules of activities, prohibitions of practices, maintenance procedures, managerial practices, or structural features that prevent or reduce adverse impacts to waters of Washington State. As described in Volume I of this surface water manual, BMPs for long-term management of surface water at developed sites can be divided into three main categories:

- BMPs addressing the volume and timing of surface water flows;
- BMPs addressing prevention of pollution from potential sources; and
- BMPs addressing treatment of runoff to remove sediment and other pollutants.

This volume of the surface water manual focuses mainly on the first category. It presents techniques of hydrologic analysis, and BMPs related to management of the amount and timing of surface water flows from developed sites. The purpose of this volume is to provide guidance on the estimation and control of surface water runoff quantity.

BMPs for preventing pollution of surface water runoff and for treating contaminated runoff are presented in Volumes IV and V, respectively.

## 1.2 Content and Organization of this Volume

Volume III of the surface water manual contains four chapters. Chapter 1 serves as an introduction. Chapter 2 reviews methods of hydrologic analysis, covers the use of hydrograph methods for designing BMPs, and provides an overview of various computerized modeling methods and analysis of closed depressions. Chapter 3 describes flow control BMPs and provides design specifications for roof downspouts and detention facilities. It also provides design considerations of infiltration facilities for flow control. Chapter 4 describes the requirements for analysis and design of conveyance systems.

The two Appendices to this volume contain the isopluvial maps for Western Washington and more detailed information on pilot infiltration testing.

### **1.3 How to Use this Volume**

Volume I should be consulted to determine Minimum Requirements for flow management (e.g. Minimum Requirements #4, #5 and #7, and Additional Requirement #1 in Volume I, Chapter 3). After the Minimum Requirements have been determined, this volume should be consulted to design flow management facilities. These facilities can then be included in Stormwater Site Plans (see Volume I, Chapter 4).

# Chapter 2 - Hydrologic Analysis

---

The broad definition of hydrology is “the science which studies the source, properties, distribution, and laws of water as it moves through its closed cycle on the earth (the hydrologic cycle).” As applied in this manual, however, the term “hydrologic analysis” addresses and quantifies only a small portion of this cycle. That portion is the relatively short-term movement of water over the land resulting directly from precipitation and called surface water or stormwater runoff. Localized and long-term groundwater movement must also be of concern, but generally only as this relates to the movement of water on or near the surface, such as stream base flow or infiltration systems.

The purpose of this chapter is to define the minimum computational standards required, to outline how these may be applied, and to reference where more complete details may be found, should they be needed. This chapter also provides details on the hydrologic design process; that is, what are the steps required in conducting a hydrologic analysis, including flow routing.

## 2.1 Minimum Computational Standards

The minimum computational standards depend on the type of information required and the size of the drainage area to be analyzed, as follows:

1. For the purpose of designing runoff treatment BMPs, a calibrated continuous simulation hydrologic model based on the EPA’s HSPF (Hydrologic Simulation Program-Fortran) should be used to calculate runoff and determine the water quality design flow rates. In the absence of a continuous model, the Soil Conservation Service (SCS) now Natural Resources Conservation Service (NRCS) Unit Hydrograph (SCSUH) method, or equivalent hydrograph techniques such as the Santa Barbara Urban Hydrograph (SBUH) method must be used to calculate runoff and determine the water quality design flow rates.

For the purpose of designing runoff treatment BMPs that are sized based upon the volume of runoff (wetpool treatment facilities), the NRCS curve number method should be used to determine the water quality design storm. The water quality design storm is the volume of runoff predicted from the 6-month, 24-hour storm.

For the purpose of designing flow control BMPs, a calibrated continuous simulation hydrologic model, based on the EPA’s HSPF, must be used where available. Where a calibrated continuous hydrologic model is not available the use of the SBUH method with the parameters specified in Volume I Minimum Requirement # 7 “Interim Guideline” is recommended for runoff flow control purposes.

The circumstances under which different methodologies apply are summarized below:

<b>Summary of the Application Design Methodologies</b>		
<b>Method</b>	<b>BMP Designs in Western Washington</b>	
	<b>Treatment</b>	<b>Flow Control</b>
SCSUH/SBUH	Method applies for BMPs that are sized based on the design 24-hr runoff volume in Volume 5. <b>Note:</b> These BMPs don't require generating a hydrograph.	Modified method applies where an approved continuous runoff model is not available. See Volume I, Minimum Requirement # 7: Flow Control, "Interim Guideline"
Continuous Model	Method applies for BMPs that are sized based on the design runoff flow rates in Volume 5.	Method applies where available

2. If a basin plan is being prepared, then the hydrologic analysis must be performed using a continuous simulation model such as EPA's HSPF model, EPA's Stormwater Management Model (SWMM), or an equivalent model as approved by the local government.

Significant progress has been made by the United States Geological Survey (in cooperation with the counties of King, Snohomish, Pierce, and Thurston) with the development of a local version of the HSPF model. This work has involved development of "runoff files" for various land types defined by vegetation and soil type. These runoff files will describe runoff characteristics of simulated runoff from a watershed with measured runoff. As a result, one will be able to simulate runoff from any other ungauged basin where only the distribution of land types is known. The model will be able to be applied on individual development sites of less than about 200 acres.

A continuous simulation model has a considerable advantage over the single event-based methods such as the SCSUH, SBUH, or the Rational Method. The single event model cannot take into account storm events that may occur just before or just after the single event (the design storm) that is under consideration. In addition, the runoff files generated by the HSPF model are the result of a considerable effort to introduce local parameters and actual rainfall data into the model and are therefore believed to result in better estimation of runoff than the SCSUH, SBUH, or Rational methods.

### 2.1.1 Discussion of Hydrologic Analysis Methods Used for Designing BMPs

This section provides a discussion of the methodologies to be used for calculating surface water runoff from a project site. It includes a discussion of estimating surface water runoff with single event models, such as the SBUH, versus continuous simulation models.

#### **Single Event and Continuous Simulation Model**

The use of single event hydrologic models has limitations when designing flow control BMPs and efforts are underway to make improved hydrologic analysis methods more widely available and used. HSPF is a continuous simulation model that is capable of simulating a wider range of hydrologic responses than the single event models such as the SBUH method. Ecology has developed a continuous simulation hydrologic model based on the HSPF for use in western Washington (see Section 2.2). Continuous rainfall records/data files have been obtained and appropriate adjustment factors were developed as input to HSPF. Input algorithms (referred to as IMPLND and PERLND) have been developed for a number of watershed basins in King, Pierce, Snohomish, and Thurston counties. These rainfall files and model algorithms are used in the HSPF in Western Washington.

The SBUH model or a calibrated continuous simulation model based on HSPF may be used for designing runoff treatment BMPs. Please note, to meet Minimum Requirement #6 - Runoff Treatment - using the SBUH model, the water quality design storm specified in Volume I must be treated. Where a continuous simulation model is available, the treatment BMPs must be sized using the appropriate design criteria specified for the BMPs in Volume 5. The discussion below will focus on the use of the SBUH method for estimating runoff and developing a runoff hydrograph.

The SBUH method, as recommended in the 1992 Manual, tends to overestimate runoff from predeveloped areas. In Volume I, certain changes to the SBUH parameters are recommended which are intended to result in more accurate estimates of runoff using SBUH. (See Minimum Requirement # 7: Flow Control, "Interim Guideline".) The suggested changes to the SBUH parameters are based on the runoff comparisons between the SBUH model and King County Runoff Time Series (KCRS), an HSPF-based continuous simulation model.

#### **Concerns with SBUH**

A summary of the concerns with SBUH is in order.

- While SBUH may give acceptable estimates of total runoff volumes, it tends to overestimate peak flow rates from pervious areas because it cannot adequately model subsurface flow (which is a dominant flow regime for pre-development conditions in Western Washington basins). One reason SBUH overestimates the peak flow rate for pervious areas is that the actual time of concentration is typically greater than what is assumed. Better flow estimates could be made if a longer time of concentration was used. This would change both the peak flow rate (i.e., it would be lower) and the shape of the

hydrograph (i.e., peak occurs somewhat later) such that the hydrograph would better reflect actual predeveloped conditions.

Another reason for overestimation of the runoff is the curve numbers (CN) in the 1992 Manual. These curve numbers were developed by US-Natural Resources Conservation Service (NRCS), formerly the Soil Conservation Service (SCS) and published as the Western Washington Supplemental Curve Numbers. These CN values are typically higher than the standard CN values published in Technical Release 55, June 1986. In 1995, the NRCS recalled the use of the Western Washington CNs for floodplain management and found that the standard CNs better describe the hydrologic conditions for rainfall events in Western Washington. However, based on runoff comparisons with the KCRTS better estimates of runoff are obtained when using the Western Washington CNs for the developed areas such as parks, lawns, and other landscaped areas.

Note: The CNs in this manual are changed to those in the Technical Release 55 except for the open spaces category for the developed areas which include, lawn, parks, golf courses, cemeteries, and landscaped areas. For these areas, the Western Washington CNs are used. These changes are intended to provide better runoff estimates using the SBUH method.

The other major weakness of the current use of SBUH is that it is used to model a 24-hour storm event, which is too short to model longer-term storms in Western Washington. The use of a longer-term (e.g. 3- or 7-day storm) is perhaps better suited for Western Washington.

The SBUH model may not be adequate for modeling the hydrologic conditions in Western Washington and therefore the use of a locally calibrated HSPF is recommended.

### **Treatment**

When designing a runoff treatment BMP, SBUH or a calibrated continuous simulation hydrologic model based on HSPF may be used to develop the inflow hydrograph to the BMP. SBUH tends to underestimate the time of concentration, thus the peak flow rate occurs too early. This would affect the treatment BMPs that are designed to achieve a specified residence time (designs are more conservative). Calculation of the residence time is sensitive to the shape of the inflow hydrograph. The inflow hydrograph is also of fundamental importance when designing an infiltration or filtration BMP as these BMPs are sized based on a routing of the inflow hydrograph through the BMP. The best solution at this time is to try to account for subsurface flow when estimating the time of concentration. For sites with low impervious cover, this will increase the time of concentration, thus reducing the peak flow rate and shifting the peak rate to a somewhat later time. Note that for BMPs which maintain "permanent pools" (e.g., wet ponds) none of the above concerns apply since the permanent pool volume is adequately predicted by SBUH.



## **Flow Control**

Where a continuous runoff model is not available, it is necessary to use a modified SBUH approach described in Volume I, Minimum Requirement # 7: Flow Control, "Interim Guideline". The modified SBUH approach approximates a design intended to achieve the flow duration standard by adjusting the target peak flow standard, restricting other variables, and applying a volume correction factor. The volume correction factor in Figure 2.1 is based on the post development impervious cover and is necessary where the predeveloped condition is modeled as pasture. This correction factor is to be applied to the volume of the BMP without changing its depth or the design of the outlet structure, thus an increase in surface area will result.

Note: It is not necessary to apply the correction factor to the BMP volume for the runoff treatment storm.

Appendix III-A contains isopluvial maps for the 2, 10, and 100-year, 24-hour storm events, which are needed for matching the pre-development and post-development peak runoff associated with these storms.

Other precipitation frequency data may be obtained, for a fee, through Western Regional Climate Center (WRCC) at Tel: (775) 674-7010. WRCC can generate 1-30 day precipitation frequency data for the location of interest using data from 1948 to present.

## **2.2 Western Washington Hydrology Model**

This section summarizes the assumptions made in creating the Western Washington Hydrology Model (WWHM) and discusses limitations of the model. More information on the WWHM can be found in Appendix III-B.

### **Limitations to the WWHM**

The WWHM has been created for the specific purpose of sizing surface water control facilities for new developments in Western Washington. The WWHM can be used for a range of conditions and developments; however, certain limitations are inherent in this software. These limitations are described below.

The WWHM uses the EPA HSPF software program to do all of the rainfall-runoff and routing computations. Therefore, HSPF limitations are included in the WWHM. For example, backwater or tailwater control situations are not explicitly modeled by HSPF. This is also true in the WWHM.

In addition, the WWHM is limited in its routing capabilities. The user is allowed to input a single surface water control facility and runoff is routed through this facility. If the proposed development site contains multiple facilities in series or involves routing through a natural lake, pond, or wetland in addition to a surface water control facility then the user should use HSPF to do the routing computations and additional analysis. The user may also use the interim modeling guidelines described in Section 3.5.7, Volume I. As of the publication date of this manual, certain model

enhancements to the next version of WWHM are being planned that include adding the capability of routing through multiple facilities.

Routing effects become more important as the drainage area increases. For this reason it is recommended that the WWHM not be used for drainage areas greater than one-half square mile (320 acres). The WWHM can be used for small drainage areas less than an acre in size.

### **Assumptions made in creating the WWHM**

#### **Precipitation data.**

- The WWHM uses long-term (43-50 years) precipitation data to simulate the potential impacts of land use development in Western Washington. A minimum period of 20 years is required to simulate enough peak flow events to produce accurate flow frequency results.
- A total of 17 precipitation stations are used, representing the different rainfall regimes found in Western Washington.
- These stations represent rainfall at elevations below 1500 feet - snowfall and snowmelt are not included in the WWHM.
- The primary source for precipitation data is National Weather Service stations.
- The computational time step used in the WWHM is one hour. The one-hour time step was selected to better represent the temporal variability of actual precipitation than daily data.

#### **Precipitation multiplication factors.**

- The WWHM uses precipitation multiplication factors to increase or decrease recorded precipitation data to better represent local rainfall conditions.
- The factors are based on the ratio of the 24-hour, 25-year rainfall intensities for the representative precipitation gage and the surrounding area represented by that gage's record.
- The factors have been placed in the WWHM database and linked to each county's map. They will be transparent to the general user, however, the advanced user will have the ability to change the coefficient for a specific site. Changes made by the user will be recorded in the WWHM output.

#### **Pan evaporation data.**

- The WWHM uses pan evaporation coefficients to compute the actual evapotranspiration potential (AET) for a site, based on the potential evapotranspiration (PET) and available moisture supply. AET accounts for the precipitation that returns to the atmosphere without becoming runoff.

- The pan evaporation coefficients have been placed in the WWHM database and linked to each county's map. They will be transparent to the general user. The advanced user will have the ability to change the coefficient for a specific site. These changes will be recorded in the WWHM output.

**Soil data.**

- The WWHM uses three predominate soil type to represent the soils of Western Washington: till, outwash, and saturated.
- The user determines actual local soil conditions for the specific development planned and inputs that data into the WWHM. The user inputs the number of acres of outwash (A/B), till (C/D), and saturated soils for the site conditions.
- Additional soils will be included in the WWHM if appropriate HSPF parameter values are found to represent other major soil groups.

**Vegetation data.**

- The WWHM will represent the vegetation of Western Washington with three predominate vegetation categories: forest, pasture, and landscaped area (also known as grass).
- The WWHM assumes that predevelopment land conditions are forest (the default condition), although the user has the option of specifying pasture if there is documented evidence that pasture vegetation was native to the predevelopment site.

**Development land use data.**

- Development land use data are used to represent the type of development planned for the site and are used to determine the appropriate size of the required surface water mitigation facility.
- For the purposes of the WWHM developed land is divided into two major categories: standard residential and non-standard residential/commercial.
- Standard residential development makes specific assumptions about the amount of impervious area per lot and its division between driveways and rooftops. Streets and sidewalk areas are input separately. Ecology has selected a standard impervious area of 4200 square feet per residential lot, with 1000 square feet of that as driveway, walkways, and patio area, and the remainder as rooftop area.
- The WWHM distinguishes between effective impervious area and non-effective impervious area in calculating total impervious area.
- Credits are given for infiltration and dispersion of roof runoff and for use of porous pavement for driveway areas (Standard Residential category only).

- For non-standard residential/commercial development the user inputs the roof area, landscape area, street, sidewalk, parking areas, and any appropriate non-developed forest and pasture areas.
- Forest and pasture vegetation areas are only appropriate for separate undeveloped parcels dedicated as open space, wetland buffer, or park within the total area of the development. ***Development areas must only be designated as forest or pasture where legal restrictions can be documented that protect these areas from future disturbances.***
- The WWHM provides options for bypassing a portion of the runoff from the development area around a surface water detention facility and/or having offsite inflow enter the development area.

#### Application of WWHM in Redevelopments Projects

Redevelopment requirements may allow, for some portions of the redevelopment project area, the predeveloped condition to be modeled as the existing condition rather than forested or pasture condition. For the purposes of modeling using WWHM, project areas where flow mitigation is not required may be modeled as Offsite-Inflow.

#### **Pervious and Impervious Land Categories (PERLND and IMPLND parameter values)**

- In WWHM (and HSPF) pervious land categories are represented by PERLNDs; impervious land categories by IMPLNDs
- The WWHM provides 16 unique PERLND parameters that describe various hydrologic factors that influence runoff and 4 parameters to represent IMPLND.
- These values are based on regional parameter values developed by the U.S. Geological Survey for watersheds in Western Washington (Dinicola, 1990) plus additional HSPF modeling work conducted by AQUA TERRA Consultants.
- Surface runoff and interflow will be computed based on the PERLND and IMPLND parameter values. Groundwater flow is not computed. It is assumed that very little or no groundwater flow from small catchments reaches the surface to become runoff. This is consistent with King County procedures (King County, 1998).

#### **Guidance for flow control standards.**

Flow control standards are used to determine whether or not a proposed surface water facility will provide a sufficient level of mitigation for the additional runoff from land development.

There are two flow control standards stated in the Ecology Manual: Minimum Requirement #7 - Flow Control and Minimum Requirement #8 - Wetlands Protection (see Volume I). Minimum Requirement #7 specifies specific flow frequency and flow duration ranges for which the

postdevelopment runoff cannot exceed predevelopment runoff. Minimum Requirement #8 specifies that discharges to wetlands must maintain the hydrologic conditions, hydrophytic vegetation, and substrate characteristics necessary to support existing and designated beneficial uses.

Minimum Requirement #7 specifies that surface water discharges to streams shall match developed discharge durations to predeveloped durations for the range of predeveloped discharge rates from 50% of the 2-year peak flow up to the full 50-year peak flow. In addition, the developed peak discharge rates should not exceed the predeveloped peak discharge rates for 2-, 10-, and 50-year return periods. In general, matching discharge durations between 50% of the 2-year and 50-year will result in matching the peak discharge rates in this range.

- The WWHM computes the predevelopment 2- through 100-year flow frequency values and computes the post-development runoff 2- through 100-year flow frequency values from the outlet of the proposed stormwater facility.
- The model uses pond discharge data to compare the predevelopment and postdevelopment peak flows and durations and determines if the flow control standards have been met.
- There are three criteria by which flow duration values are compared:
  1. If the postdevelopment flow duration values exceed any of the predevelopment flow levels between 50% and 100% of the 2-year predevelopment peak flow values (100 Percent Threshold) then the Standard (1) flow duration requirement has not been met.
  2. If the postdevelopment flow duration values exceed any of the predevelopment flow levels between 100% of the 2-year and 100% of the 50-year predevelopment peak flow values more than 10 percent of the time (110 Percent Threshold) then the Standard (1) flow duration requirement has not been met.
  3. If more than 50 percent of the flow duration levels exceed the 100 percent threshold then the Standard (1) flow duration requirement has not been met.

Minimum Requirement #8 specifies that discharges to wetlands must maintain the hydrologic conditions, hydrophytic vegetation, and substrate characteristics necessary to support existing and designated beneficial uses. Criteria for determining maximum allowed exceedences in alterations to wetland hydroperiods are provided in guidelines cited in Guide Sheet 2B of the Puget Sound Wetland Guidelines (Azous and Horner, 1997). Because wetland hydroperiod computations are relatively complex and are site specific they will not be included in the WWHM. HSPF is required for wetland hydroperiod analysis.

## 2.3 Single Event Hydrograph Method

Hydrograph analysis utilizes the standard plot of runoff flow versus time for a given design storm, thereby allowing the key characteristics of runoff such as peak, volume, and phasing to be considered in the design of drainage facilities.

The physical characteristics of the site and the design storm determine the magnitude, volume, and duration of the runoff hydrograph. Other factors such as the conveyance characteristics of channel or pipe, merging tributary flows, branching of channels, and flooding of lowlands can alter the shape and magnitude of the hydrograph. In the following sections, the key elements of hydrograph analysis are presented, namely:

- Design storm hyetograph
- Runoff parameters
- Hydrograph synthesis
- Hydrograph routing
- Hydrograph summation and phasing
- Computer applications

### 2.3.1 Design Storm Hyetograph

All storm event hydrograph methods require the input of a rainfall distribution or design storm hyetograph. The design storm hyetograph is essentially a plot of rainfall depth versus time for a given design storm frequency and duration. It is usually presented as a dimensionless plot of unit rainfall depth (increment rainfall depth for each time interval divided by the total rainfall depth) versus time.

The hyetographs in Table 2.1 represent the rainfall distributions in Washington State. The hyetograph Type IA is the standard NRCS rainfall distribution as modified by King County and resolved to 10-minute time intervals for greater sensitivity in computing peak rates of runoff in urbanizing basins of Western Washington. The hyetograph was interpolated from the NRCS mass distribution by Surface Water Management Division staff from King County. It may differ slightly from the distribution used in other NRCS-based computer models, particularly those that are not resolved to 10-minute time intervals. The hyetograph Type II is the standard NRCS rainfall distribution for Eastern Washington. Figure 2.2 shows the 24-hr design storm hyetographs for the Types IA and II rainfall distributions.

The design storm hyetograph is constructed by multiplying the dimensionless hyetograph times the rainfall depth (in inches) for the design storm.

The total depth of rainfall (in tenths of an inch) for storms of 24-hour duration and 2, 5, 10, 25, 50, and 100-year recurrence intervals are published by the National Oceanic and Atmospheric Administration

(NOAA). The information is presented in the form of “isopluvial” maps for each state. Isopluvial maps are maps where the contours represent total inches of rainfall for a specific duration. Isopluvial maps for the 2, 5, 10, 25, 50, and 100-year recurrence interval and 24-hour duration storm events can be found in the NOAA Atlas 2, “Precipitation - Frequency Atlas of the Western United States, Volume IX-Washington.” Appendix III-A provides the isopluvials for the 2, 10, and 100-year, 24-hour design storms. Other precipitation frequency data may be obtained through Western Regional Climate Center (WRCC) at Tel: (775) 674-7010. WRCC can generate 1-30 day precipitation frequency data for the location of interest using data from 1948 to present (currently August 2000).

For project sites in Western Washington with tributary drainage areas above elevation 1000 MSL, an additional total precipitation must be added to the total depth of rainfall, for the 25, 50, and 100-year design storm events, to account for the potential average snowmelt which occurs during major storm events.

This snowmelt factor ( $M_s$ ) may be computed as follows:

This snowmelt factor ( $M_s$ ) is

$M_s$  (in inches) =  $0.004 (MB_{el} - 1000)$ ;  
where:

$MB_{el}$  = the mean tributary basin elevation above sea level (in feet).

Example:

Given: Project location at an elevation of  $MB_{el} = 1837$  feet.

Design Storm Event: 100-year  $P_{100} = 7$  inches

Compute:  $M_s = 0.004 (MB_{el} - 1000) = (0.004) (1837 - 1000)$   
 $= 3.35$  inches

Adjusted  $P_{100} = P_{100} + M_s$   
 $= (7 \text{ inches}) + (3.35 \text{ inches})$   
 $= 10.35$  inches

### 2.3.2 Runoff Parameters

All storm event hydrograph methods require input of parameters that describe physical drainage basin characteristics. These parameters provide the basis from which the runoff hydrograph is developed. This section describes the three key parameters (area, curve number, and time of concentration) used to develop the hydrograph using the method of hydrograph synthesis discussed in Section 2.3.3.

## **Area**

The proper selection of homogeneous basin areas is required to obtain the highest degree of accuracy in hydrograph analysis. Significant differences in land use within a given drainage basin must be addressed by dividing the basin area into subbasin areas of similar land use and/or runoff characteristics. For example, a drainage basin consisting of a concentrated residential area and a large forested area should be divided into two subbasin areas accordingly. Hydrographs should then be computed for each subbasin area and summed to form the total runoff hydrograph for the basin.

To further enhance the accuracy of hydrograph analysis, all pervious and impervious areas within a given basin or subbasin must be analyzed separately, i.e., curve numbers and time of concentrations must be determined separately. This may be done by computing separate hydrographs for each area and combining them to form the total runoff hydrograph. This procedure is explained further in Section 2.3.3 "Hydrograph Synthesis." By analyzing pervious and impervious areas separately, the errors associated with averaging these areas are avoided and the true shape of the runoff hydrograph is better approximated.

## **Curve Number**

The NRCS (formerly SCS) has, for many years, conducted studies of the runoff characteristics for various land types. After gathering and analyzing extensive data, NRCS has developed relationships between land use, soil type, vegetation cover, interception, infiltration, surface storage, and runoff. The relationships have been characterized by a single runoff coefficient called a "curve number." The National Engineering Handbook - Section 4: Hydrology (NEH-4, SCS, August 1972) contains a detailed description of the development and use of the curve number method.

NRCS has developed "curve number" (CN) values based on soil type and land use. They can be found in "Urban Hydrology for Small Watersheds", Technical Release 55 (TR-55), June 1986, published by the NRCS. The combination of these two factors is called the "soil-cover complex." The soil-cover complexes have been assigned to one of four hydrologic soil groups, according to their runoff characteristics. NRCS has classified over 4,000 soil types into these four soil groups. Table 2.2 shows the hydrologic soil group of most soils in the state of Washington and provides a brief description of the four groups. For details on other soil types refer to the NRCS publication mentioned above (TR-55, 1986).

**The NRCS did not map the soils within the City of Tacoma. As a result, there are no resources available to classify Tacoma soils according to the Soil Types listed in Table 2.2. Consequently, soils within the City limits shall be assumed to fall in Hydrologic Soil Group C unless grain size distribution and/or permeability testing indicate otherwise. Refer to Section 3.2.5, Volume III for details on appropriate soil testing methods.**

Table 2.3 shows the CNs, by land use description, for the four hydrologic soil groups. These numbers are for a 24-hour duration storm and typical antecedent soil moisture condition preceding 24-hour storms.



The following are important criteria/considerations for selection of CN values.

Many factors may affect the CN value for a given land use. For example, the movement of heavy equipment over bare ground may compact the soil so that it has a lesser infiltration rate and greater runoff potential than would be indicated by strict application of the CN value to developed site conditions.

CN values can be area weighted when they apply to pervious areas of similar CNs (within 20 CN points). However, high CN areas should not be combined with low CN areas. In this case, separate hydrographs should be generated and summed to form one hydrograph unless the low CN areas are less than 15 percent of the subbasin.

Separate CN values must be selected for the pervious and impervious areas of an urban basin or subbasin. For residential districts the percent impervious area given in Table 2.3 must be used to compute the respective pervious and impervious areas. For proposed commercial areas, planned unit developments, etc., the percent impervious area must be computed from the site plan. For all other land uses the percent impervious area must be estimated from best available aerial topography and/or field reconnaissance. The pervious area CN value must be a weighted average of all the pervious area CNs within the subbasin. The impervious area CN value shall be 98.

For storm duration other than 24 hours, an adjustment must be made to the CN values given in Table 2.3. Based on information obtained from SCS, the following equation shall be used for adjusting these CNs for the seven-day design storm:

$$CN (7 \text{ day}) = 0.1549 CN + 0.8451 [(CN^{2.365} / 631.8) + 15]$$

Example: The following is an example of how CN values are selected for a sample project.

Select CNs for the following development:

Existing Land Use	-	forest (undisturbed)
Future Land Use	-	residential plat (3.6 DU/GA)
Basin Size	-	60 acres
Soil Type	-	Hydrologic Soil Group C (for Tacoma)

Therefore, for the existing condition, a CN of 70 is read from Table 2.3. For the developed condition with 3.6 DU/GA the percent impervious of 39 percent is interpolated from Table 2.3 and used to compute pervious and impervious areas of 36.6 acres and 23.4 acres, respectively. The 36.6 acres of pervious area is assumed to be in Fair condition (for a conservative design) with residential yards and lawns. Therefore, a CN of 90 is read from Table 2.3. The impervious area CN value is 98. The result of this example is summarized below:

On-Site Condition	Existing	Developed
Land use	Forest	Residential
Pervious area	60 ac.	36.6 ac.
CN of pervious area	70	90
Impervious area	0 ac.	23.4 ac.
CN of impervious area	--	98

**SCS Curve Number Equations for determination of runoff depths and volumes** The rainfall-runoff equations of the SCS curve number method relates a land area's runoff depth (precipitation excess) to the precipitation it receives and to its natural storage capacity, as follows:

$$\begin{aligned} & Q_d = (P - 0.2S)^2 / (P + 0.8S) && \text{for } P \geq 0.2S \\ \text{and } & Q_d = 0 && \text{for } P < 0.2S \end{aligned}$$

Where:

$Q_d$  = runoff depth in inches over the area,  
 $P$  = precipitation depth in inches over the area, and  
 $S$  = potential maximum natural detention, in inches over the area, due to infiltration, storage, etc.

The area's potential maximum detention,  $S$ , is related to its curve number, CN:

$$S = (1000 / CN) - 10$$

The combination of the above equations allows for estimation of the total runoff volume by computing total runoff depth,  $Q_d$ , given the total precipitation depth,  $P$ . For example, if the curve number of the area is 70, then the value of  $S$  is 4.29. With a total precipitation for the design event of 2.0 inches, the total runoff depth would be:

$$Q_d = [2.0 - 0.2 (4.29)]^2 / [2.0 + 0.8 (4.29)] = 0.24 \text{ inches}$$

This computed runoff represents inches over the tributary area. Therefore, the total volume of runoff is found by multiplying  $Q_d$  by the area (with necessary conversions):

**Calculating the design volume for treatment BMPs for which the design criterion is based on the volume of runoff**

$$\begin{aligned} \text{Total runoff} \\ \text{Volume} &= 3,630 \times Q_d \times A \\ \text{(cu. ft.)} & \quad \quad \quad \text{(cu. ft./ac. in.)} \quad \text{(in)} \quad \quad \text{(ac)} \end{aligned}$$

If the area is 10 acres, the total runoff volume is:

$$3,630 \text{ cu. ft./ac. in.} \times 0.24 \text{ in.} \times 10 \text{ ac.} = 8,712 \text{ cu. ft.}$$

This is the design volume for treatment BMPs for which the design criterion is based on the volume of runoff.

When developing the runoff hydrograph, the above equation for  $Q_d$  is used to compute the incremental runoff depth for each time interval from the incremental precipitation depth given by the design storm hyetograph.

This time distribution of runoff depth is often referred to as the precipitation excess and provides the basis for synthesizing the runoff hydrograph.

**Travel Time and Time of Concentration for Use in Hydrograph Analysis**

(based on the methods described in SCS TR-55)

Travel time ( $T_t$ ) is the time it takes water to travel from one location to another in a watershed.  $T_t$  is a component of time of concentration ( $T_c$ ), which is the time it takes for runoff to travel from the hydraulically most distant point of the watershed to the outlet.  $T_c$  is computed by summing all the travel times for consecutive components of the drainage conveyance system.  $T_c$  influences the shape and peak of the runoff hydrograph. Urbanization usually decreases  $T_c$ , thereby increasing peak discharge.  $T_c$  can be increased as a result of either ponding behind small or inadequate drainage systems (including storm drain inlets and road culverts) or by reduction of land slope through grading.

Water moves through a watershed as sheet flow, shallow concentrated flow, open channel flow or some combination of these. The type of flow that occurs is best determined by field inspection.

Travel time ( $T_t$ ) is the ratio of flow length to flow velocity:

$$T_t = \frac{L}{60V}$$

Where:

$T_t$  = travel time (minutes)

$L$  = flow length (feet)

$V$  = average velocity (feet/sec) and

60 = conversion factor from seconds to minutes

Time of concentration ( $T_c$ ) is the sum of  $T_t$  values for the various consecutive flow segments.

$$T_c = T_{t_1} + T_{t_2} + \dots + T_{t_m}$$

Where:

$T_c$  = time of concentration (minutes) and

$m$  = number of flow segments

**Sheet Flow**

Sheet flow is runoff that flows over the ground surface as a thin, even layer, not concentrated in a channel. It usually occurs in the headwater of streams. With sheet flow, the friction value ( $n_s$ ) (a modified Manning's effective roughness coefficient that includes the effect of raindrop impact; drag over the plane surface; obstacles such as litter, crop ridges and rocks; and erosion and transportation of sediment) is used. These  $n_s$  values are for very shallow flow depths of about 0.1 foot and are only used for travel lengths up to 300 feet. Table 2.4 gives Manning's  $n_s$  values for sheet flow for various surface conditions. Table 2.5 gives Manning's  $n$  normal values for various surfaces.

For sheet flow of up to 300 feet, use Manning's kinematic solution to directly compute  $T_t$ .

$$T_t = \frac{0.42(n_s L)^{0.8}}{(P_2)^{0.527} (s_o)^{0.4}}$$

Where:

$T_t$  = travel time (min),

$n_s$  = sheet flow Manning's effective roughness coefficient (from Table 2.4).

$L$  = flow length (ft),

$P_2$  = 2-year, 24-hour rainfall (in), and

$s_o$  = slope of hydraulic grade line (land slope, ft/ft)

### **Velocity Equation**

A commonly used method of computing average velocity of flow, once it has measurable depth, is the following equation:

$$V = k\sqrt{s_o}$$

Where:

$V$  = velocity (ft/s)

$k$  = time of concentration velocity factor (ft/s)

$s_o$  = slope of flow path (ft/ft)

"k" is computed for various land covers and channel characteristics with assumptions made for hydraulic radius using the following rearrangement of Manning's equation:

$$k = \frac{1.49(R)^{0.667}}{n}$$

Where:

$R$  = an assumed hydraulic radius

$n$  = Manning's roughness coefficient for open channel flow

**Shallow Concentrated Flow:** After a maximum of 300 feet, sheet flow is assumed to become shallow concentrated flow. The average velocity for this flow can be calculated using the  $k_s$  values from Table 2.4 in which average velocity is a function of watercourse slope and type of channel. After computing the average velocity using the Velocity Equation above, the travel time ( $T_t$ ) for the shallow concentrated flow segment can be computed using the Travel Time Equation described above.

**Open Channel Flow:** Open channels are assumed to begin where surveyed cross section information has been obtained, where channels are visible on aerial photographs, or where lines indicating streams appear (in blue) on United States Geological Survey (USGS) quadrangle sheets. The  $k_c$  values from Table 2.4 used in the Velocity Equation above or water surface profile information can be used to estimate average flow velocity. Average flow velocity is usually determined for

bankfull conditions. After average velocity is computed the travel time ( $T_i$ ) for the channel segment can be computed using the Travel Time Equation above.

**Lakes or Wetlands:** Sometimes it is necessary to estimate the velocity of flow through a lake or wetland at the outlet of a watershed. This travel time is normally very small and can be assumed as zero. Where significant attenuation may occur due to storage effects, the flows should be routed using the “level pool routing” technique described in Section 2.3.4

**Limitations:** The following limitations apply in estimating travel time ( $T_i$ ).

Manning's kinematic solution should not be used for sheet flow longer than 300 feet.

In watersheds with storm drains, carefully identify the appropriate hydraulic flow path to estimate  $T_c$ . Storm sewers generally handle only a small portion of a large event. The rest of the peak flow travels by streets, lawns, and so on, to the outlet. Consult a standard hydraulics textbook to determine average velocity in pipes for either pressure or non-pressure flow.

A culvert or bridge can act as a reservoir outlet if there is significant storage behind it. A hydrograph should be developed to this point and the “level pool routing” technique described in Section 2.3.4 should be used to determine the outflow rating curve through the culvert or bridge.

Example: The following is an example of travel time and time of concentration calculations.

Given: An existing drainage basin having a selected flow route composed of the following five segments. Note: Drainage basin is in Federal Way and has a  $P2 = 2.1$  inches.

Segment 1:  $L = 200$  ft. Forest with dense brush (sheet flow)  
 $s_o = 0.03$  ft/ft,  $n_s = 0.80$

Segment 2:  $L = 300$  ft. Pasture (shallow concentrated flow)  
 $s_o = 0.04$  ft/ft,  $k_s = 11$

Segment 3:  $L = 50$  ft. Small pond (year around)  
 $s_o = 0.00$  ft/ft,  $k_c = 0$

Segment 4:  $L = 300$  ft. Grassed waterway (intermittent channel)  
 $s_o = 0.05$  ft/ft,  $k_c = 17$

Segment 5:  $L = 500$  ft. Grass-lined stream (continuous)  
 $s_o = 0.02$  ft/ft,  $k_c = 27$

Calculate travel times ( $T_{i_s}$ ) for each reach and then sum them to calculate the drainage basin time of concentration ( $T_c$ ).

Segment 1: Sheet flow ( $L < 300$  feet),

$$T_i = \frac{0.42(n_s L)^{0.8}}{(P_2)^{0.527} (s_o)^{0.4}}$$

$$T_1 = \frac{(0.42)[(0.80)(200)]^{0.8}}{(2.1)^{0.527} (0.03)^{0.4}} = 68 \text{ minutes}$$

Segment 2: Shallow concentrated flow,

$$V = k\sqrt{s_o}$$

$$V_2 = (11)\sqrt{(0.04)} = 2.2 \text{ ft/s}$$

$$T_2 = \frac{L}{60V} = \frac{(300)}{60(2.2)} = 2 \text{ minutes}$$

Segment 3: Flat water surface

$$T_3 = 0 \text{ minutes}$$

Segment 4: Intermittent channel flow

$$V_4 = (17)\sqrt{(0.05)} = 3.8 \text{ ft/s}$$

$$T_4 = \frac{(300)}{60(3.8)} = 1 \text{ minute}$$

Segment 5: Continuous stream

$$V_5 = (27)\sqrt{(0.02)} = 3.8 \text{ ft/s}$$

$$T_5 = \frac{(500)}{60(3.8)} = 2 \text{ minutes}$$

$$T_c = T_1 + T_2 + T_3 + T_4 + T_5$$

$$T_c = 68 + 2 + 0 + 1 + 2 = \underline{73 \text{ minutes}}$$

It is important to note how the initial sheet flow segment's travel time dominates the time of concentration computation. This will nearly always be the case for relatively small drainage basins and in particular for the existing site conditions. This also illustrates the significant impact urbanization has on the surface runoff portion of the hydrologic process.

### 2.3.3 Hydrograph Synthesis – Santa Barbara Urban Hydrograph

The Santa Barbara Urban Hydrograph (SBUH) method is described below. It is given here as a guideline only, as it is only one of the many SCS-based hydrograph methods that are available for use.

The SBUH method, like the Soil Conservation Service Unit Hydrograph (SCSUH) method, is based on the curve number (CN) approach, and also uses SCS equations for computing soil absorption and precipitation excess. The SCSUH method works by converting the incremental runoff depths (precipitation excess) for a given basin and design storm into a

runoff hydrograph via application of a dimensionless unit hydrograph. The shape of the SCS unit hydrograph (time to peak, time base, and peak) are determined by a single parameter - the basin time of concentration. The SBUH method, on the other hand, converts the incremental runoff depths into instantaneous hydrographs that are then routed through an imaginary reservoir with a time delay equal to the basin time of concentration.

The SBUH method was developed by the Santa Barbara County Flood Control and Water Conservation District, California. The SBUH method directly computes a runoff hydrograph without going through an intermediate process (unit hydrograph) as the SCSUH method does. By comparison, the calculation steps of the SBUH method are much simpler and can be programmed on a calculator or a spreadsheet program.

The SBUH method uses two steps to synthesize the runoff hydrograph:

- Step one - computing the instantaneous hydrograph, and
- Step two - computing the runoff hydrograph.

The instantaneous hydrograph,  $I(t)$ , in cfs, at each time step,  $dt$ , is computed as follows:

$$I_t = 60.5 R_t A / d_t$$

Where  $R_t$  = total runoff depth (both impervious and pervious runoffs) at time increment  $dt$ , in inches (also known as precipitation excess)

$A$  = area in acres

$d_t$  = time interval in minutes\*

\*Note: A maximum time interval of 10 minutes should be used for all design storms of 24-hour duration. A maximum time interval of 60 minutes should be used for the 100-year, 7-day design storm.

The runoff hydrograph,  $Q_t$ , is then obtained by routing the instantaneous hydrograph  $I_t$ , through an imaginary reservoir with a time delay equal to the time of concentration,  $T_c$ , of the drainage basin. The following equation estimates the routed flow,  $Q_t$ :

$$Q_{t+1} = Q_t + w[I_t + I_{t+1} - 2Q_t]$$

Where:  $w = d_t / (2T_c + d_t)$

$d_t$  = time interval in minutes

Example: To illustrate the SBUH method, Tables 2.6 and 2.7 show runoff hydrograph values computed by this method for both existing and developed conditions. Figure 2.3 illustrates the hydrographs for existing and developed conditions. Note: This example was prepared using the Excel 5.0 spreadsheet program and illustrates how the method can be used with a personal computer. Copies of this program and a Fortran version are available (with minimal documentation) from King County Surface Water Management Division.

### 2.3.4 Hydrograph Routing (Sizing Detention Facilities)

A methodology is presented here for routing a hydrograph through an existing retention/detention facility or closed depression, and for sizing a new retention/detention facility using hydrograph analysis.

**Storage Routing Technique:** The “level pool routing” technique presented here is one of the simplest and most commonly used hydrograph routing methods. This method is described in “Handbook of Applied Hydrology,” Chow, V. Te, 1964, and elsewhere, and is based on the continuity equation:

Inflow - Outflow = Change in Storage

$$\left[ \frac{I_1 + I_2}{2} - \frac{O_1 + O_2}{2} \right] = \frac{\Delta S}{\Delta t} = \frac{S_2 - S_1}{\Delta t}$$

Where I = Inflow at time 1 and time 2  
O = Outflow at time 1 and time 2  
S = Storage at time 1 and time 2  
 $\Delta t$  = Time interval, 2-1

The time interval,  $\Delta t$ , must be consistent with the time interval used in developing the inflow hydrograph. The time interval used for a 24-hour storm is 10 minutes while the time interval used for a 7-day storm is 60 minutes. The  $\Delta t$  variable can be eliminated by dividing it into the storage variables to obtain the following rearranged equation:

$$I_1 + I_2 + 2S_1 - O_1 = O_2 + 2S_2$$

If the time interval,  $\Delta t$ , is in minutes and the units of storage (S) are in cubic feet (cf), this can be converted to cubic feet per second (cfs) by dividing by 60.

The terms  $I_1$ ,  $I_2$ ,  $O_1$ , and  $S_1$  are known from the inflow hydrograph and from the storage and outflow values of the previous time step. The unknowns  $O_2$  and  $S_2$  can be solved interactively from the given stage-storage and stage-discharge curves.

The following section gives the specific hydrograph routing steps:

#### 1. Develop Stage-Storage Relationship

For retention/detention facilities with vertical sides (vaults), the stored volume is simply the bottom area times the height.

For trapezoidal shaped ponds with equal side slopes the stored volume in terms of an aspect ratio  $R_A$ , and bottom width  $b_W$ , can be calculated from the following equation:



$$\text{Volume } S(h) = \frac{1}{3}h^3 \tan^2 \theta + h^2 \tan \theta (R_A b_W + b_W) + h R_A b_W^2$$

Where  $h$  = stage height (ft) or water depth above pond bottom

$\tan \theta$  = horizontal component of the side slope

(i.e.,  $\tan \theta = \frac{3}{1}$  or 3 for a side slope of 3:1)

$b_L$  = length of the pond bottom

$b_W$  = width of the pond bottom

$S(h)$  = storage (cu. ft.) at stage height,  $h$ .

$R_A$  = Length/Width

#### Trapezoidal Pond Dimensions

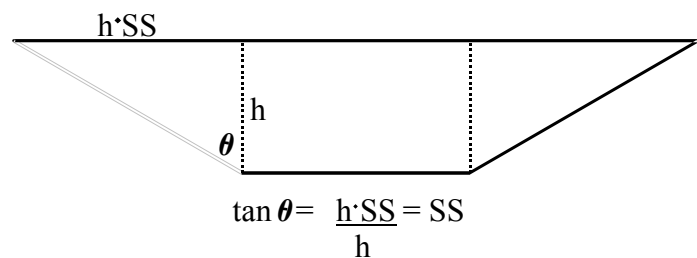
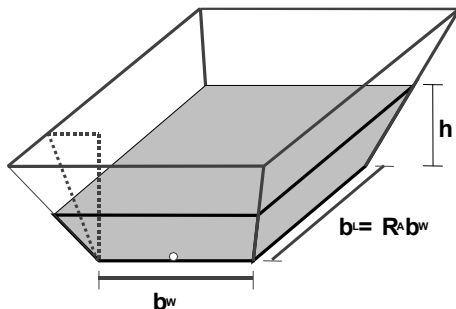
SS = Horizontal component of the side slope (SS:H to 1:V)

$b_L$  = Bottom length of the pond

$b_W$  = Bottom width of the pond

$R_A$  = Bottom area aspect ratio (length to width ratio)

Bottom length  $b_L$  in terms of bottom width  $b_W$ ;  $b_L = R_A \cdot b_W$



For irregularly shaped areas the stage-storage curve may be developed as follows:

- a. Obtain topographic contours of an existing or proposed reservoir/basin facility site and planimeter (or otherwise compute) the area enclosed by each contour. For example, see Figure 2.4 in which each contour represents a one-foot interval. Contour 71 is the lowest portion of the site and represents zero storage. Contour 76 represents a potential stage of 5 feet above the bottom of the facility.
- b. Calculate the average area between each contour. For the example given above, the average area between contours 71 and 72 would be:

$$\frac{600 + 4,400}{2} = \underline{2,500 \text{ sq.ft.}}$$

- c. Calculate the volume between contours by multiplying the average area between contours by the difference in elevation. To illustrate, the volume between contours 71 and 72 would be:

$$(2,500)(1 \text{ foot}) = \underline{2,500 \text{ cu. ft.}}$$

Similarly,

Area 72-73	-	6,550 cu. ft.
Area 73-74	-	10,050 cu. ft.
Area 74-75	-	12,950 cu. ft.
Area 75-76	-	16,750 cu. ft.

- d. Define the total storage below each contour. This is just the sum of the volumes computed in the previous step for the contour in question. For example, there is no storage below contour 71; 2,500 cu. ft. below Contour 72, and (6,550 + 2,500 = 9,050 cu. ft. below Contour 73).

In summary,

<u>Contours</u>	<u>Stage</u>	<u>Sum of Volumes</u>	<u>Total Volume</u>
Contours 71-72	1	0 + 2,500	= 2,500 cu. ft.
Contours 72-73	2	2,500 + 6,500	= 9,050 cu. ft.
Contours 73-74	3	9,050 + 10,050	= 19,100 cu. ft.
Contours 74-75	4	19,100 + 12,950	= 32,050 cu. ft.
Contours 75-76	5	32,050 + 16,750	= 48,800 cu. ft.

The stage-storage relationship for this examples is shown in Figure 2.5

## 2. Develop a Routing Curve

A routing curve is simply a plot of outflow for a given stage versus a term,  $O + 2S$ , for the same stage. This curve may be easily plotted by setting up a table like Table 2.8. The units for the expression of outflow,  $O$ , are cubic-feet per second for the time period of interest. For this example, the time period,  $\Delta t$ , of 60 minutes will be used for illustrative purposes. (Usually  $\Delta t$  will be 10 minutes to correspond to the time steps used in preparing the hydrographs.) Therefore, all variables in the rearranged continuity equation must have the units of cfs. This means that the storage which was plotted in cubic feet (cf) must be converted from cf to cfs by dividing it by the time interval,  $\Delta t$ . From the above example, for the storage below Contour 72 this would be:

$$\frac{S}{\Delta t} = \frac{2,500 \text{ ft}^3}{(60 \text{ min})} \times \frac{1 \text{ min}}{60 \text{ sec}} = \underline{0.694 \text{ cfs}}$$

For this example, the maximum allowable outflow was arbitrarily selected to be 4.0 cfs (this value is normally the pre-developed runoff rate from the site) and the maximum stage in the pond of 5 feet.

The "Outflow" column in Table 2.8 is the stage-discharge relationship for an 8-inch orifice outlet pipe. The 8-inch pipe size was chosen because the maximum allowable outflow is approximately 4.0 cfs at the maximum desired storage depth of 5 feet. From Table 2.8 the routing curve is plotted as shown in Figure 2.6.

### 3. Route Inflow Hydrograph through Proposed Storage Facility

The final step is to route the inflow hydrograph through the proposed storage facility by completing successive columns of Table 2.9 for each time period. For illustrative purposes a simple triangular shaped inflow hydrograph will be assumed as shown in Figure 2.7.

The routing table is completed by the following steps, using the routing equation:

$$I_n + I_{n+1} + 2S_n - O_n = O_{n+1} + 2S_{n+1} \quad (\text{For each time period, } \Delta t)$$

Where subscripts  $n$  and  $n+1$  are used to indicate the beginnings of the time periods  $n$  and  $n+1$  respectively.

#### **Steps for Calculating Outflow Using Level Pool Routing**

1. Inflow,  $I_n$ , is the inflow at the beginning of each time period and is read from the inflow hydrograph for each time period. For period 1,  $I_n$  in this example is zero, and this is entered in Row (1) and Column (1) of the routing table. For period 2,  $I_n = 2.34$  cfs and is entered in Row (2) Column (1) of the routing table.
2.  $I_{n+1}$ , inflow at the end of each time period, is read from the inflow hydrograph, and entered in Column (2) for each time period. This same value is the initial inflow,  $I_n$ , for the next time period. For our example,  $I_{n+1}$ , for time period 1 is 2.34 cfs; this is also entered in Column (1) of time period 2 as  $I_n$ .
3. Two times the initial storage,  $2S_n$ , is entered in Column (3). For the example, initial storage for time period 1 is zero. Subsequent values entered as  $2S_n$ , are calculated after the remaining values for the preceding time period are filled in. This is explained below.
4. Enter in Column (4) the sum of Columns (1), (2), and (3), for the appropriate time period. In this case, the sum for time period 1 is 2.34 cfs.
5.  $O_n$ , outflow initially for the time period, is entered in Column (5). For time period 1,  $O_n$ , is zero in this case. Subsequent values are read from the routing curve after Column (6) has been calculated. This is explained below.

6. From the routing equation, the entry in Column (6),  $O_{n+1} + 2S_{n+1}$ , is the difference between Column (4),  $I_n + I_{n+1} + 2S_n$ , and Column (5),  $O_n$ . For time period 1, this value is 2.34 cfs. This is entered and the process repeated.
7. The value of  $O_n$  for any time period is obtained by taking the previous time period value of  $O_{n+1} + 2S_{n+1}$ , and then finding the corresponding value of Outflow  $O$  in Table 2.8. For example,  $O_n$  for time period 2 is found by taking the value for  $O_{n+1} + 2S_{n+1}$ , for time period 1 or 2.34 cfs, then by interpolating Table 2.8 a value of 1.30 cfs is obtained for  $O_n$  for time period 2 and is entered in Column (5).
8. The value of  $2S_n$  for the time period 2 is the difference between the value of  $(O_{n+1} + 2S_{n+1})$  for time period 1 and the value of  $O_n$  for time period 2. For this example,
 
$$O_{n+1} + 2S_{n+1} = 2.34 \text{ (for time period 1)}$$

$$O_n = 1.30 \text{ (for time period 2)}$$

$$2S_n = (O_{n+1} + 2S_{n+1}) - O_n = 1.04 \text{ (for time period 2)}$$
 Therefore, enter 1.04 in Column (3) for time period 2.
9. Find the sum of Columns (1), (2), and (3) and enter value in Column (4).
10. Subtract value in Column (5) from Column (4) and enter result in Column (6).
11. Refer to Table 2.8 for next value of  $O_n$ , corresponding to result of Step 10.

Continue this process until the outflow hydrograph, as represented by the tabulated values of  $O_n$ , returns to zero.

Column (7) of entries in the Table 2.9 (stage at the beginning of each time period) is obtained by dividing each value of  $2S_n$  by 2, and referring to the stage-storage curve, Figure 2.5. For example, for time period 3,  $2S_n$  equals 4.39 cfs-min, half of which is 2.19 cfs-min. Referring to stage-storage curve for storage 2.19 cfs-min. (or  $2.19 \times 3600 = 7,901$  cu. ft.), a stage of 1.82 feet is obtained by interpolating the data for Figure 2.5. Adding these stages to the elevation of the first contour (71) allows floodplain or maximum water surface (Column (8)) for each time period to be computed.

Finally, plot the values of  $O_n$  for each time period to plot the complete outflow hydrograph, as shown in Figure 2.8. The volume that must be stored is represented by the dark shaded area, and may be obtained through graphical techniques. The volume may also be closely estimated from the largest tabulated value of  $2S_n$ , divided by 2, and converted to cubic feet ( $19.49/2 \times 3,600 = 35,082 \text{ ft}^3$ ). This will exactly coincide with the true peak only if two hydrographs cross exactly at the end of a time interval. However, this inaccuracy in volume would be very small, and for practical purposes may be neglected.

In summary, the characteristics of the sample detention facility and the selected eight-inch orifice outlet are such that the peak runoff rate will be reduced below the required 4.0 cfs. Furthermore, the full 5 feet of

**Sizing a  
Detention Facility  
for Multiple  
Design Storm  
Events**

available storage is not used and the maximum floodplain elevation generated in the pond is 75.18 feet. This indicates that additional trials or iterations could be performed to optimize the size and outlet control of this sample detention pond.

To design a storage facility to meet given performance requirements, for example, to match the pre-development and post-development runoff for the 2, 10, and 100-year storms, it is usually necessary to perform many iterative routings to arrive at a minimum facility size with the proper outlet (orifice) control. Each iterative routing requires that the facility size (stage-storage curve) and/or outlet configuration (stage-discharge curve) be adjusted and tested for performance. Such iteration can be cumbersome, even with the use of a computer. To minimize the number of iterations, a graphical evaluation of the developed inflow hydrographs is useful in approximating the storage volume and outlet configuration of a hypothetical detention pond that meets the performance requirements, prior to beginning the iteration process to finalize the design of a detention facility.

The following example presents a graphical approach to approximating storage volume and outlet configuration as displayed in Figure 2.9.

1. Assume the following performance requirements (allowable release rates) and developed peak inflow rates have been noted from hydrographs generated for the purposes of sizing a standard on-site detention pond:

<u>Design Storm</u>	<u>Allowable Release</u>	<u>Developed Inflows</u>
2-year, 24-hour	$P_2Q_{rel} = 0.23 \text{ cfs}$	$P_2Q_{dev} = 1.65 \text{ cfs}$
10-year, 24-hour	$P_{10}Q_{rel} = 1.40 \text{ cfs}$	$P_{10}Q_{dev} = 3.46 \text{ cfs}$
100-year, 24-hour	$P_{100}Q_{rel} = 3.47 \text{ cfs}$	$P_{100}Q_{dev} = 5.89 \text{ cfs}$

Note: This example illustrates detaining the peak flows for the 2, 10, and 100-year, 24-hour duration design storms.

The required performance for the 100-year design storm may in some cases be more than the pre-developed flow rate depending on downstream conditions.

2. Plots of the developed inflow hydrographs are used to graphically approximate the detention storage required to achieve the performance.
3. Starting with the 2-year hydrograph, the 2-year allowable release rate ( $P_2Q_{rel}$ ) (which must not be exceeded) is plotted as a horizontal line extending from time zero to the point where it intercepts the falling limb of the hydrograph. A line is drawn from the beginning of the inflow hydrograph to this point. This line approximates the outflow rating curve of a control structure of a hypothetical detention facility that would restrict outflow to not exceed  $P_2Q_{rel}$  and thus approximates the rising limb of a hypothetical outflow hydrograph.

4. As in standard inflow-outflow hydrograph analysis, the area under the inflow hydrograph, less the area under the rising limb of the hypothetical outflow hydrograph, graphically approximates the amount of inflow which must be stored, detained and released once the inflow hydrograph falls below the allowable release rate. This volume of storage for the 2-year storm (as shaded) is termed  $S_2$  and can thus be approximated by measuring the shaded area with a planimeter. In this example, the area under the inflow hydrograph equals 29,648 cu. ft. and the area under the rising limb of the hypothetical outflow hydrograph equals 9,658 cu. ft.  $\therefore S_2 = 29,648 - 9,658 = \underline{19,990 \text{ cu. ft.}}$ .
5. The 10 and 100-year developed inflow hydrographs must now each be examined to determine which will require the most storage volume in addition to the 19,990 cu. ft. approximated for the 2-year storm. Note: The amount of storage volume needed to control the 10-year storm may exceed that of the 100-year when using this method. This occurs because the peak flows for the 10- and 100-year inflow hydrographs are similar in magnitude, and the difference between 10-year allowable release and developed peak rates can be substantially greater than for the 100-year. The interception point with the  $P_{10}Q_{rel}$  thus occurs further down the falling limb than for the 100-year, resulting in a larger storage volume required.

The 10 or 100-year allowable release rate ( $P_{10}Q_{rel}$  or  $P_{100}Q_{rel}$ ) (which must not be exceeded) is plotted as a horizontal line extending from time zero to the point where it intercepts the falling limb of the corresponding hydrograph.

By trial and error, the time ( $T_{2\text{-year}}$ ) at which the  $S_2$  volume occurs, while maintaining  $P_2Q_{rel}$ , is determined by planimeter. From this point, a line is drawn to connect to the  $P_{10}Q_{rel}$  or  $P_{100}Q_{rel}$  point on the falling limb. The area from time  $T_{2\text{-year}}$  under the inflow hydrograph to this point, less the area under the rising limb of the hypothetical outflow hydrograph (shown as the slender shaded triangle(s)), represents the additional storage volume needed to meet the required performance. The total storage volume  $S_{10}$  or  $S_{100}$  can then be computed by adding the additional storage volume to  $S_2$ .

6. From the storage volumes computed above, choose the largest of the three volumes for the initial pond sizing. In this case the 100-year volume,  $S_{100}$ , is the largest. Therefore, call it  $S_d$ .

$$S_d = 23,955 \text{ cu. ft.}$$

7. Using the volume equation for trapezoidal shaped ponds and the design volume  $S_d$  from above, estimate the detention pond's dimensions by first determining the pond's bottom width,  $b_w$ .

Assuming a 3:1 side slope, a design depth ( $h_d$ ) of 4 feet, and a square bottom (bottom area aspect ratio or length to width ratio,  $R_A = 1$ ).

$$\tan \theta = 3$$

$$R_A = \text{Bottom Area Aspect Ratio} = 1$$

$$\text{Bottom Length } b_L = R_A b_W$$

$$\text{Volume } S(h) = \frac{4}{3}h^3 \tan^2 \theta + h^2 \tan \theta (b_L + b_W) + h b_L b_W$$

$S(h)$  in terms of the aspect ratio and

$$b_W = \frac{4}{3}h^3 \tan^2 \theta + h^2 \tan \theta (R_A b_W + b_W) + h R_A b_W^2$$

Rearranging the volume equation to solve for  $b_W$ :

$$b_W^2 h R_A + b_W h^2 \tan \theta (1 + R_A) + \frac{4}{3}h^3 \tan^2 \theta - S(h) = 0$$

Solve the quadratic for bottom width  $b_W$ :

$$b_W = \frac{-(1 + R_A)h^2 \tan \theta + \sqrt{[(1 + R_A)h^2 \tan \theta]^2 - 4R_A h(\frac{4}{3}h^3 \tan^2 \theta - S(h))}}{2R_A h}$$

$$b_W = \frac{-(1+1)(4^2)(3) + \sqrt{[(1+1)(4^2)(3)]^2 - (4)(1)(4)(\frac{4}{3})(4^3)(3^2) - 23,955}}{(2)(1)(4)} = \underline{65.08 \text{ ft.}}$$

8. Compute the stage-storage curve using the bottom width calculated above and the following equation for  $S(h)$  in terms of the aspect ratio and  $b_W$  for trapezoidal shaped ponds. Remembering that for the square bottomed pond in our example the bottom area aspect ratio or length to width ratio,  $R_A = 1$ , and the bottom length  $b_L = R_A b_W$ .

$$\text{Volume } S(h) = \frac{4}{3}h^3 \tan^2 \theta + h^2 \tan \theta (R_A b_W + b_W) + h R_A b_W^2$$

9. From the stage-storage curve shown in Figure 2.10, determine the depth,  $h$ , required for the 2-year storage volume.

For  $S_2 = 19,990$  cu. ft. and interpolating Table 2.10:  $h_2 = \underline{3.48 \text{ feet}}$

*Special Note: It has been found through experience that usually only two orifices are necessary to meet 2, 10 and 100-year performance requirements. The bottom orifice is therefore sized to meet the 2-year performance requirement, while the top orifice is located above the 2-year water surface and is sized and situated such that both the 10-year and 100-year performance requirements are met. This is further illustrated as the example continues.*

10. Size the bottom orifice for the 2-year allowable release,  $P_2 Q_{rel} = 0.23$  cfs, using the following derivation of the orifice equation:

$$Q = CA\sqrt{2gh} \quad \text{Standard orifice equation}$$

Where:

- C = entrance loss coefficient = 0.62 (typical)
- A = area of orifice =  $\pi d^2/4$ , where d = diameter of orifice
- g = acceleration of gravity = 32.2 ft/s<sup>2</sup>
- h = head on orifice

For 2-year allowable release:

$$P_2 Q_{rel} = 0.23 \text{ cfs}; h_2 = 3.48 \text{ feet}$$

$$P_2 Q_{rel} = C A_b \sqrt{2gh_2}$$

rearranging to solve for  $A_b$ :

$$A_b = P_2 Q_{rel} / C \sqrt{2gh_2}$$

substituting for diameter:

$$\begin{aligned} \pi d_b^2/4 &= P_2 Q_{rel} / C \sqrt{2gh_2} \\ d_b^2 &= 4P_2 Q_{rel} / \pi C \sqrt{2gh_2} \\ d_b &= \sqrt{4P_2 Q_{rel} / \pi C \sqrt{2gh_2}} \\ d_b &= \sqrt{4(0.23) / \pi (0.62) \sqrt{2(32.2)(3.48)}} \\ d_b &= 0.18 \text{ feet (= 2.16 inches)} \end{aligned}$$

11. Sketch and consider the following flow control restrictor schematic as shown in Figure 2.11:

12. Size and situate the top orifice at or above the 2-year water surface ( $WS_{2yr.}$ ). This may require some trial and error. The release rate for this orifice is:

$$P_{100} Q_{rel} = Q_t + Q_b, \text{ where } P_{100} Q_{rel} = 3.47 \text{ cfs (total allowable flow at maximum head)}$$

$$Q_b = C A_b \sqrt{2gh} \text{ where } A_b = \pi d^2/4$$

$$d_b = 0.18 \text{ feet, thus } A_b = \pi(0.18)^2/4 = \underline{0.03 \text{ ft}^2}$$

$$h = 4 \text{ feet}$$

$$\therefore Q_b = (0.62)(0.025)\sqrt{2(32.2)4} = \underline{0.30 \text{ cfs}}$$

$$Q_t = 3.47 \text{ cfs} - 0.30 \text{ cfs} = \underline{3.17 \text{ cfs}}$$

The size of this orifice will depend on its vertical location as specified by its head,  $h_t$ .  $h_t$  in this example, must be less than the design depth of 4 ft. minus the two-year depth of 3.48 ft. or 0.52 ft. so that the top orifice is above the 2-year water surface. Therefore, try a  $h_t = 0.51$  ft:



$$\text{Top Orifice Diameter, } d_t = \sqrt{\frac{4Q_t}{\pi C \sqrt{2gh_t}}}$$

$$d_t = \sqrt{\frac{4(3.17)}{\pi(0.62)\sqrt{2(32.2)(0.51)}}} = \underline{1.07 \text{ feet}} (= 12.8 \text{ inches})$$

13. Check for 10-year volume ( $S_{10}$ ) by:

a. Computing  $h_{10}$  (see Figure 2.11)

$$Q_{10} = Q_t - Q_2 ; \text{ or in this case } P_{10}Q_{rel} = Q_t - P_2Q_{rel}$$

$$P_{10}Q_{rel} = CA_t \sqrt{2gh_{10}} + P_2Q_{rel}$$

Solving for  $h_{10}$ :

$$h_{10} = \left[ \frac{P_{10}Q_{rel} - P_2Q_{rel}}{CA_t} \right]^2 \times (2g)^{-1}$$

$$A_t = \pi d^2/4 \text{ where } d = 1.07 \text{ ft.}; A_t = 0.90 \text{ ft}^2$$

$$h_{10} = \left[ \frac{1.40 - 0.23}{0.62(0.90)} \right]^2 \times (2(32.2))^{-1} = 0.07 \text{ ft.}$$

b. Computing  $h_{10} = 3.48 \text{ feet} + 0.07 \text{ feet} = 3.55 \text{ feet}$

c. Check the stage-storage curve to see if there is sufficient volume at  $h_{10} = 3.55 \text{ feet}$ :

$$\text{For } h_{10} = 3.55 \text{ feet; } S(h) = 20,503 \text{ cu. ft.}$$

$$\text{Recalling } S_{10} = 20,150 \text{ cu. ft.}$$

$$\underline{20,503 \text{ cu. ft.} > 20,150 \text{ cu. ft.}} \text{ Okay}$$

*Note: Since the top-orifice size of 12.84 inches is too large to feasibly install in the upper 0.51 feet of the riser pipe, a notch weir must be substituted. Also, the 100-year water surface in this example is shown at the same elevation as the top of the riser. This will not necessarily be the case. In fact, it may be slightly above the riser and still meet performance.*

The stage/storage/discharge information for a hypothetical detention facility developed above can then be used as a guide to design the actual detention facility. The design is checked using the "level pool routing" technique described at the beginning of this section. The stage/storage/discharge data from the actual facility design is used with each of the developed inflow hydrographs routed through the facility in order to demonstrate that the required performance is met.

The practical minimum orifice sizing may be between ½ inch and 1 inch in diameter. This could restrict the ability of small sites to satisfy some detention requirements. Local governments should pursue alternative detention requirements, such as the use of regional facilities (for a group of small lots, for example), for small sites.

This is the point in the process where a number of iterations may be required in order to calibrate and optimize the actual facility design to meet performance with the minimal amount of storage volume. Use of a spreadsheet program or other commercially available software will facilitate these calculations. Note that hand-calculated hydrographs and flow routing will no longer be accepted.

### **2.3.5 Hydrograph Summation and Phasing**

One of the key advantages of hydrograph analysis is the ability to accurately describe the cumulative effect of runoff from several basins and/or sub-basins having different runoff characteristics and travel times. This cumulative effect is best characterized by a single hydrograph, which is obtained by summing the individual hydrographs from tributary basins at a particular “discharge point of interest.” The general procedure for performing a hydrograph summation is described below:

#### ***Hydrograph Summation***

1. Select the “discharge point of interest” at which the hydrographs will be summed.
2. Estimate the time required for each hydrograph to travel from its point discharge to the “discharge point of interest.” This travel time can be estimated using the methods presented in Section 2.3.2. under “Travel Time and Time of Concentration.”
3. Shift each hydrograph according to its travel time to the “discharge point of interest” as shown below in Figure 2.12.
4. Sum the shifted hydrographs by adding the ordinate flow values at each time interval as shown below in Figure 2.13.

#### ***Hydrograph Phasing Analysis***

The ability to characterize cumulative effects through the summation of hydrographs provides a valuable tool for analyzing the interaction of on-site and off-site hydrographs both before and after development. This interaction of hydrographs is generally referred to as “hydrograph phasing” due to the similarity with compound wave-shapes. This hydrograph phasing analysis is required in order to determine the effect of the compound hydrograph shape on the downstream system.

The general procedure for performing a hydrograph phasing analysis is as follows:

Select the “discharge point of interest” at which the on-site and off-site runoff hydrographs will be summed and compute travel times as explained under “Hydrograph Summation.”

Compute the pre-developed on-site hydrograph and the existing off-site hydrograph for the design storm of interest. Shift and sum these hydrographs as explained under “Hydrograph Summation.”

Compute the post-developed on-site hydrograph. If on-site detention is provided, this hydrograph will be the outflow hydrograph from the facility. Shift and sum this hydrograph with the existing off-site hydrograph.

Plot the above two summations as shown in Figure 2.14 below to obtain a comparison of cumulative effects:

Figure 2.14 illustrates how a development with standard on-site detention can cause an increase in peak flow at some point downstream. If this is the case, the local government shall require that this condition be addressed by reducing the release rate from the detention facility such that the cumulative effect downstream is negligible as shown in Figure 2.15.

### 2.3.6 Computer Applications

The computations required to generate the runoff hydrographs and perform the level pool routing techniques presented in this chapter can be performed using a spreadsheet program or commercially available software. *Note: Hand calculations will no longer be accepted by the City per Section 3.5.7.4, Volume I.*

Software developers have prepared programs that they market and support to model stormwater runoff and perform routing using the SBUH method. The City of Tacoma may provide a list of these programs as they approve them for use.

## 2.4 Closed Depression Analysis

The analysis of closed depressions requires careful assessment of the existing hydrologic performance in order to evaluate the impacts a proposed project will have. The applicable requirements (see Minimum Requirement #7) and the local government's Sensitive Areas Ordinance and Rules (if applicable) should be thoroughly reviewed prior to proceeding with the analysis. A calibrated continuous simulation hydrologic model must be used for closed depression analysis and design of mitigation facilities. Where an adequately calibrated continuous simulation model is not available, the procedures below may be followed.

**Analysis and Design Criteria:** The infiltration rates used in the analysis of closed depressions must be determined according to the procedures in Section 3.2. For closed depressions containing standing water, soil texture tests must be performed on dry land adjacent to, and on opposite sides of the standing water (as is feasible). The elevation of the testing surface at the bottom of the test pit must be one foot above the standing water elevation. A minimum of four tests must be performed to prepare an average surface infiltration rate.

Projects proposing to modify or compensate for replacement storage in a closed depression must meet the design criteria for detention ponds as described in this volume.

**Method of Analysis:** Closed depressions are analyzed using hydrographs routed as described in Section 2.3.4 “Hydrograph Routing.” Infiltration must be addressed where appropriate. In assessing the impacts of a proposed project on the performance of a closed depression there are three cases that dictate different approaches to meeting Minimum Requirement #7 and applicable local requirements. Note that where there is a flooding potential, concern about rising ground water levels, or there are local sensitive area ordinances and rules, this analysis may not be sufficient and the local governments may require more stringent analysis.

**Case 1:** The 100-year, 7-day duration design storm flow from the drainage basin tributary to the closed depression is routed into the closed depression using only infiltration as outflow. If predevelopment runoff does not overflow the closed depression, then no runoff may leave the closed depression for the 100-year, 7-day duration design storm following development of a proposed project. This may be accomplished by excavating additional storage volume in the closed depression (subject to all applicable requirements, for example providing a defined overflow system). See Table 2.11 for a summary of Case 1.

**Case 2:** The 100-year, 7-day duration design storm flow from the drainage basin tributary to the closed depression is routed into the closed depression using only infiltration as outflow. If runoff does overflow the closed depression, then the 100-year, 24-hour duration design storm flow from the drainage basin tributary to the closed depression is routed into the closed depression using only infiltration as outflow. If this does not cause overflow, then the allowable release rate is that which occurred for the 100-year, 7-day duration design storm. This performance objective can be met by excavating additional storage volume in the closed depression (subject to all applicable requirements, for example providing a defined overflow system). See Table 2.11 for a summary of Case 2.

**Case 3:** The 100-year, 7-day duration design storm flow and the 100-year, 24-hour duration design storm flow from the drainage basin tributary to the closed depression are routed into the closed depression using only infiltration as outflow, and both cause overflow to occur. Then the closed depression must be analyzed as a detention/infiltration pond. The required performance, therefore, is to meet the runoff duration standard in Volume 1 using an adequately calibrated continuous simulation model. This will require that a control structure, emergency overflow spillway, access road, and other design criteria are met and, if it is to be maintained by the City, the closed depression must be placed in a tract dedicated to the City. If it is to be privately maintained, it must be located in a drainage easement dedicated to the owners and successors of the properties using the closed depression for drainage purposes. See Table 2.11 for a summary of Case 3.

<b>Table 2.1 24-Hour Design Storm Hyetograph Values - 10 minute Resolution</b>		
<b>Time (hour)</b>	<b>Type IA Rainfall Distribution</b>	<b>Type II Rainfall Distribution</b>
0	0	0
0.166667	0.004	0.0017
0.333333	0.004	0.0016
0.5	0.004	0.0017
0.666667	0.004	0.0017
0.833333	0.004	0.0016
1	0.004	0.0017
1.166667	0.004	0.0017
1.333333	0.004	0.0016
1.5	0.004	0.0017
1.666667	0.004	0.0017
1.833333	0.005	0.0016
2	0.005	0.0017
2.166667	0.005	0.0017
2.333333	0.005	0.0016
2.5	0.005	0.0017
2.666667	0.005	0.0017
2.833333	0.006	0.0016
3	0.006	0.0017
3.166667	0.006	0.0033
3.333333	0.006	0.0034
3.5	0.006	0.0033
3.666667	0.006	0.0033
3.833333	0.007	0.0034
4	0.007	0.0033
4.166667	0.007	0.0025
4.333333	0.007	0.0025
4.5	0.007	0.0025
4.666667	0.007	0.0025
4.833333	0.0082	0.0025
5	0.0082	0.0025
5.166667	0.0082	0.0025
5.333333	0.0082	0.0025
5.5	0.0082	0.0025
5.666667	0.0082	0.0025
5.833333	0.0095	0.0025
6	0.0095	0.0025
6.166667	0.0095	0.0042
6.333333	0.0095	0.0041
6.5	0.0095	0.0042
6.666667	0.0095	0.0042
6.833333	0.0134	0.0041
7	0.0134	0.0042

<b>Table 2.1 (cont.) 24-Hour Design Storm Hyetograph Values - 10 minute Resolution</b>		
<b>Time (hour)</b>	<b>Type IA Rainfall Distribution</b>	<b>Type II Rainfall Distribution</b>
7.166667	0.0134	0.0033
7.333373	0.018	0.0034
7.5	0.018	0.0033
7.666667	0.034	0.0033
7.833333	0.054	0.0034
8	0.027	0.0033
8.166667	0.018	0.005
8.333333	0.0134	0.005
8.5	0.0134	0.005
8.666667	0.0134	0.005
8.833333	0.0088	0.005
9	0.0088	0.005
9.166667	0.0088	0.005
9.333333	0.0088	0.005
9.5	0.0088	0.005
9.666667	0.0088	0.005
9.833333	0.0088	0.005
10	0.0088	0.005
10.16667	0.0088	0.0083
10.33333	0.0088	0.0084
10.5	0.0088	0.0083
10.66667	0.0088	0.0117
10.83333	0.0072	0.0116
11	0.0072	0.0117
11.16667	0.0072	0.02
11.33333	0.0072	0.02
11.5	0.0072	0.055
11.66667	0.0072	0.1
11.83333	0.0072	0.19
12	0.0072	0.075
12.16667	0.0072	0.03
12.33333	0.0072	0.008
12.5	0.0072	0.008
12.66667	0.0072	0.008
12.83333	0.0057	0.008
13	0.0057	0.008
13.16667	0.0057	0.0083
13.33333	0.0057	0.0084
13.5	0.0057	0.0083
13.66667	0.0057	0.0083
13.83333	0.0057	0.0084
14	0.0057	0.0083

**Table 2.1 (cont.)  
24-Hour Design Storm Hyetograph Values - 10 minute Resolution**

Time (hour)	Type IA Rainfall Distribution	Type II Rainfall Distribution
14.16667	0.0057	0.0058
14.33333	0.0057	0.0059
14.5	0.0057	0.0058
14.66667	0.0057	0.0058
14.83333	0.005	0.0059
15	0.005	0.0058
15.16667	0.005	0.0033
15.33333	0.005	0.0034
15.5	0.005	0.0033
15.66667	0.005	0.0033
15.83333	0.005	0.0034
16	0.005	0.0033
16.16667	0.005	0.0042
16.33333	0.005	0.0041
16.5	0.005	0.0042
16.66667	0.005	0.0042
16.83333	0.004	0.0041
17	0.004	0.0042
17.16667	0.004	0.0025
17.33333	0.004	0.0025
17.5	0.004	0.0025
17.66667	0.004	0.0025
17.83333	0.004	0.0025
18	0.004	0.0025
18.16667	0.004	0.0033
18.33333	0.004	0.0034
18.5	0.004	0.0033
18.66667	0.004	0.0033
18.83333	0.004	0.0034
19	0.004	0.0033
19.16667	0.004	0.0025
19.33333	0.004	0.0025
19.5	0.004	0.0025
19.66667	0.004	0.0025
19.83333	0.004	0.0025
20	0.004	0.0025
20.16667	0.004	0.0017
20.33333	0.004	0.0016
20.5	0.004	0.0017
20.66667	0.004	0.0017
20.83333	0.004	0.0016
21	0.004	0.0017
21.16667	0.004	0.0025

<b>Table 2.1 (cont.) 24-Hour Design Storm Hyetograph Values - 10 minute Resolution</b>		
<b>Time (hour)</b>	<b>Type IA Rainfall Distribution</b>	<b>Type II Rainfall Distribution</b>
21.33333	0.004	0.0025
21.5	0.004	0.0025
21.66667	0.004	0.0025
21.83333	0.004	0.0025
22	0.004	0.0025
22.16667	0.004	0.0017
22.33333	0.004	0.0016
22.5	0.004	0.0017
22.66667	0.004	0.0017
22.83333	0.004	0.0016
23	0.004	0.0017
23.16667	0.004	0.0017
23.33333	0.004	0.0016
23.5	0.004	0.0017
23.66667	0.004	0.0017
23.83333	0.004	0.0016
24	0.004	0.0017



Table 2.2 Hydrologic Soil Series for Selected Soils in Washington State			
Soil Type	Hydrologic Soil Group	Soil Type	Hydrologic Soil Group
Agnew	C	Hoko	C
Ahl	B	Hoodsport	C
Aits	C	Hoogdal	C
Alderwood	C	Hoypus	A
Arents, Alderwood	B	Huel	A
Arents, Everett	B	Indianola	A
Ashoe	B	Jonas	B
Baldhill	B	Jumpe	B
Barneston	C	Kalaloch	C
Baumgard	B	Kapowsin	C/D
Beausite	B	Katula	C
Belfast	C	Kilchis	C
Bellingham	D	Kitsap	C
Bellingham variant	C	Klaus	C
Boistfort	B	Klone	B
Bow	D	Lates	C
Briscot	D	Lebam	B
Buckley	C	Lummi	D
Bunker	B	Lynnwood	A
Cagey	C	Lystair	B
Carlsborg	A	Mal	C
Casey	D	Manley	B
Cassolary	C	Mashel	B
Cathcart	B	Maytown	C
Centralia	B	McKenna	D
Chehalis	B	McMurray	D
Chesaw	A	Melbourne	B
Cinebar	B	Menzel	B
Clallam	C	Mixed Alluvial	variable
Clayton	B	Molson	B
Coastal beaches	variable	Mukilteo	C/D
Colter	C	Naff	B
Custer	D	Nargar	A
Custer, Drained	C	National	B
Dabob	C	Neilton	A
Delphi	D	Newberg	B
Dick	A	Nisqually	B
Dimal	D	Nooksack	C
Dupont	D	Norma	C/D
Earlmont	C	Ogarty	C
Edgewick	C	Olete	C
Eld	B	Olomount	C
Elwell	B	Olympic	B
Esquatzel	B	Orcas	D
Everett	A	Oridia	D
Everson	D	Orting	D
Galvin	D	Oso	C
Getchell	A	Ovall	C
Giles	B	Pastik	C
Godfrey	D	Pheeney	C
Greenwater	A	Phelan	D
Grove	C	Pilchuck	C
Harstine	C	Potchub	C
Hartnit	C	Poulsbo	C
Hoh	B	Prather	C

Table 2.2 Hydrologic Soil Series for Selected Soils in Washington State (cont)			
Soil Type	Hydrologic Soil Group	Soil Type	Hydrologic Soil Group
Puget	D	Solleks	C
Puyallup	B	Spana	D
Queets	B	Spanaway	A/B
Quilcene	C	Springdale	B
Ragnar	B	Sulsavar	B
Rainier	C	Sultan	C
Raught	B	Sultan variant	B
Reed	D	Sumas	C
Reed, Drained or Protected	C	Swantown	D
Renton	D	Tacoma	D
Republic	B	Tanwax	D
Riverwash	variable	Tanwax, Drained	C
Rober	C	Tealwhit	D
Salal	C	Tenino	C
Salkum	B	Tisch	D
Sammamish	D	Tokul	C
San Juan	A	Townsend	C
Scamman	D	Triton	D
Schneider	B	Tukwila	D
Seattle	D	Tukey	C
Sekiu	D	Urbana	C
Semiahmoo	D	Vailton	B
Shalcar	D	Verlot	C
Shano	B	Wapato	D
Shelton	C	Warden	B
Si	C	Whidbey	C
Sinclair	C	Wilkeson	B
Skipopa	D	Winston	A
Skykomish	B	Woodinville	B
Snahopish	B	Yelm	C
Snohomish	D	Zynbar	B
Solduc	B		

Notes:

Hydrologic Soil Group Classifications, as Defined by the Soil Conservation Service:

A = (Low runoff potential) Soils having low runoff potential and high infiltration rates, even when thoroughly wetted. They consist chiefly of deep, well to excessively drained sands or gravels and have a high rate of water transmission (greater than 0.30 in/hr.).

B = (Moderately low runoff potential). Soils having moderate infiltration rates when thoroughly wetted and consist chiefly of moderately deep to deep, moderately well to well drained soils with moderately fine to moderately coarse textures. These soils have a moderate rate of water transmission (0.15-0.3 in/hr.).

C = (Moderately high runoff potential). Soils having low infiltration rates when thoroughly wetted and consist chiefly of soils with a layer that impedes downward movement of water and soils with moderately fine to fine textures. These soils have a low rate of water transmission (0.05-0.15 in/hr.).

D = (High runoff potential). Soils having high runoff potential. They have very low infiltration rates when thoroughly wetted and consist chiefly of clay soils with a high swelling potential, soils with a permanent high water table, soils with a hardpan or clay layer at or near the surface, and shallow soils over nearly impervious material. These soils have a very low rate of water transmission (0-0.05 in/hr.).

\* = From SCS, TR-55, Second Edition, June 1986, Exhibit A-1. Revisions made from SCS, Soil Interpretation Record, Form #5, September 1988 and various county soil surveys.

<b>Table 2.3</b>				
<b>Runoff Curve Numbers for Selected Agricultural, Suburban, and Urban Areas</b>				
(Sources: TR 55, 1986, and Stormwater Management Manual, 1992. See Section 2.1.1 for explanation)				
	CNs for hydrologic soil group			
Cover type and hydrologic condition.	A	B	C	D
<b>Curve Numbers for Pre-Development Conditions</b>				
<b>Pasture, grassland, or range-continuous forage for grazing:</b>				
Fair condition (ground cover 50% to 75% and not heavily grazed).	49	69	79	84
Good condition (ground cover >75% and lightly or only occasionally grazed)	39	61	74	80
<b>Woods:</b>				
Fair (Woods are grazed but not burned, and some forest litter covers the soil).	36	60	73	79
Good (Woods are protected from grazing, and litter and brush adequately cover the soil).	30	55	70	77
<b>Curve Numbers for Post-Development Conditions</b>				
<b>Open space (lawns, parks, golf courses, cemeteries, landscaping, etc.)<sup>1</sup></b>				
Fair condition (grass cover on 50% - 75% of the area).	77	85	90	92
Good condition (grass cover on >75% of the area)	68	80	86	90
<b>Impervious areas:</b>				
Open water bodies: lakes, wetlands, ponds etc.	100	100	100	100
Paved parking lots, roofs <sup>2</sup> , driveways, etc. (excluding right-of-way)	98	98	98	98
<b>Porous Pavers and Permeable Interlocking Concrete (assumed as 85% impervious and 15% lawn)</b>				
Fair lawn condition (weighted average CNs).	95	96	97	97
Good lawn condition (weighted average CNs).	94	95	96	97
Paved	98	98	98	98
Gravel (including right-of-way)	76	85	89	91
Dirt (including right-of-way)	72	82	87	89
<b>Pasture, grassland, or range-continuous forage for grazing:</b>				
Poor condition (ground cover <50% or heavily grazed with no mulch).	68	79	86	89
Fair condition (ground cover 50% to 75% and not heavily grazed).	49	69	79	84
Good condition (ground cover >75% and lightly or only occasionally grazed)	39	61	74	80
<b>Woods:</b>				
Poor (Forest litter, small trees, brush are destroyed by heavy grazing or regular burning).	45	66	77	83
Fair (Woods are grazed but not burned, and some forest litter covers the soil).	36	60	73	79
Good (Woods are protected from grazing, and litter and brush adequately cover the soil).	30	55	70	77
<b>Single family residential<sup>3</sup>:</b>				
Dwelling Unit/Gross Acre	Should only be used for subdivisions > 50 acres	Average Percent impervious area <sup>3,4</sup>		
1.0 DU/GA		15	Separate curve number shall be selected for pervious & impervious portions of the site or basin	
1.5 DU/GA		20		
2.0 DU/GA		25		
2.5 DU/GA		30		
3.0 DU/GA		34		
3.5 DU/GA		38		
4.0 DU/GA		42		
4.5 DU/GA		46		
5.0 DU/GA		48		
5.5 DU/GA		50		
6.0 DU/GA		52		
6.5 DU/GA		54		
7.0 DU/GA		56		
7.5 DU/GA		58		
PUD's, condos, apartments, commercial businesses, industrial areas & subdivisions < 50 acres		%impervious must be computed	Separate curve numbers shall be selected for pervious and impervious portions of the site	

For a more detailed and complete description of land use curve numbers refer to chapter two (2) of the Soil Conservation Service's Technical Release No. 55, (210-VI-TR-55, Second Ed., June 1986).

<sup>1</sup> Composite CN's may be computed for other combinations of open space cover type.

<sup>2</sup> Where roof runoff and driveway runoff are infiltrated or dispersed according to the requirements in Chapter 2, the average percent impervious area may be adjusted in accordance with the procedure described under "Flow Credit for Roof Downspout Infiltration" and "Flow Credit for Roof Downspout Dispersion" in Chapter 2.

<sup>3</sup> Assumes roof and driveway runoff is directed into street/storm system.

<sup>4</sup> All the remaining pervious area (lawn) are considered to be in good condition for these curve numbers.

<b>Table 2.4</b>	
<b>“n” and “k” Values Used in Time Calculations for Hydrographs</b>	
<b>“n<sub>s</sub>” Sheet Flow Equation Manning’s Values (for the initial 300 ft. of travel)</b>	
Manning values for sheet flow only, from Overton and Meadows 1976 (See TR-55, 1986)	n <sub>s</sub>
Smooth surfaces (concrete, asphalt, gravel, or bare hand packed soil)	0.011
Fallow fields or loose soil surface (no residue)	0.05
Cultivated soil with residue cover ≤20%	0.06
Cultivated soil with residue cover >20%	0.17
Short prairie grass and lawns	0.15
Dense grasses	0.24
Bermuda grass	0.41
Range (natural)	0.13
Woods or forest with light underbrush	0.40
Woods or forest with dense underbrush	0.80
(210-VI-TR-55, Second Ed., June 1986)	
<b>“k” Values Used in Travel Time/Time of Concentration Calculations</b>	
Shallow Concentrated Flow (After the initial 300 ft. of sheet flow, R = 0.1)	k <sub>s</sub>
1. Forest with heavy ground litter and meadows (n = 0.10)	3
2. Brushy ground with some trees (n= 0.060)	5
3. Fallow or minimum tillage cultivation (n = 0.040)	8
4. High grass (n = 0.035)	9
5. Short grass, pasture and lawns (n = 0.030)	11
6. Nearly bare ground (n = 0.025)	13
7. Paved and gravel areas (n = 0.012)	27
Channel Flow (intermittent) (At the beginning of visible channels R = 0.2)	k <sub>c</sub>
1. Forested swale with heavy ground litter (n = 0.10)	5
2. Forested drainage course/ravine with defined channel bed (n = 0.050)	10
3. Rock-lined waterway (n = 0.035)	15
4. Grassed waterway (n = 0.030)	17
5. Earth-lined waterway (n = 0.025)	20
6. CMP pipe, uniform flow (n = 0.024)	21
7. Concrete pipe, uniform flow (0.012)	42
8. Other waterways and pipe	0.508/n
Channel Flow (Continuous stream, R = 0.4)	k <sub>c</sub>
9. Meandering stream with some pools (n = 0.040)	20
10. Rock-lined stream (n = 0.035)	23
11. Grass-lined stream (n = 0.030)	27
12. Other streams, man-made channels and pipe	0.807/n

**Table 2.5  
Values of the Roughness Coefficient, “n”**

Type of Channel and Description	Manning's "n" (Normal)	Type of Channel and Description	Manning's "n" (Normal)
<b>A. Constructed Channels</b>		6. Sluggish reaches, weedy deep pools	0.070
a. Earth, straight and uniform		7. Very weedy reaches, deep pools, or floodways with heavy stand of timber and underbrush	0.100
1. Clean, recently completed	0.018	b. Mountain streams, no vegetation in channel, banks usually steep, trees and brush along banks submerged at high stages	
2. Gravel, uniform selection, clean	0.025	1. Bottom: gravel, cobbles and few boulders	0.040
3. With short grass, few weeds	0.027	2. Bottom: cobbles with large boulders	0.050
b. Earth, winding and sluggish		B-2 Flood plains	
1. No vegetation	0.025	a. Pasture, no brush	
2. Grass, some weeds	0.030	1. Short grass	0.030
3. Dense weeds or aquatic plants in deep channels	0.035	2. High grass	0.035
4. Earth bottom and rubble sides	0.030	b. Cultivated areas	
5. Stony bottom and weedy banks	0.035	1. No crop	0.030
6. Cobble bottom and clean sides	0.040	2. Mature row crops	0.035
c. Rock lined		3. Mature field crops	0.040
1. Smooth and uniform	0.035	c. Brush	
2. Jagged and irregular	0.040	1. Scattered brush, heavy weeds	0.050
d. Channels not maintained, weeds and brush uncut		2. Light brush and trees	0.060
1. Dense weeds, high as flow depth	0.080	3. Medium to dense brush	0.070
2. Clean bottom, brush on sides	0.050	4. Heavy, dense brush	0.100
3. Same, highest stage of flow	0.070	d. Trees	
4. Dense brush, high stage	0.100	1. Dense willows, straight	0.150
<b>B. Natural Streams</b>		2. Cleared land with tree stumps, no sprouts	0.040
B-1 Minor streams (top width at flood stage < 100ft.)		3. Same as above, but with heavy growth of sprouts	0.060
a. Streams on plain		4. Heavy stand of timber, a few down trees, little undergrowth, flood stage below branches	0.100
1. Clean, straight, full stage no rifts or deep pools	0.030	5. Same as above, but with flood stage reaching branches	0.120
2. Same as above, but more stones and weeds	0.035		
3. Clean, winding, some pools and shoals	0.040		
4. Same as above, but some Weeds	0.040		
5. Same as 4, but more Stones	0.050		

\*Note, these “n” values are “normal” values for use in analysis of channels. For conservative design for channel capacity the “maximum” values listed in other references should be considered. For channel bank stability the minimum values should be considered.

**Table 2.6**  
**SBUH Values for Existing Site Condition**

Given: Area = 10 acres    P = 2.9 inches (10-yr, 24-hr. event)    dt = 10 minutes  
 PERVIOUS AREA:    Area = 10 acres    CN = 74    S = 3.513514    0.2S = 0.70  
 IMPERVIOUS AREA:    Area = 0 acres    CN = 98    S = 0.204082    0.2S = 0.04  
 Tc = 73 minutes    w = 0.064103    where S = potential maximum natural detention (as defined earlier)

- Column (1) = Time Increment
- Column (2) = Time (min)
- Column (3) = Type IA Storm Distribution
- Column (4) = Column (3) \* P
- Column (5) = Accumulated sum of Column (4)
- Column (6) = If (P < 0.2S) = 0, If (P > 0.2S) = (Column (5) - 0.2S)^2/(Column (5) + 0.8S), where the PERVIOUS AREA S value is used
- Column (7) = Column (6) of the present step - Column (6) of the previous step
- Column (8) = Same as Column (6) except use IMPERVIOUS AREA S value
- Column (9) = Column (8) of the present step - Column (8) of the previous step
- Column (10) = (PERVIOUS AREA/TOTAL AREA)\*Column (7)+(IMPERVIOUS AREA/TOTAL AREA)\*Column (9)
- Column (11) = (60.5\*Column (10)\*Total Area)/dt, where dt = 10 or 60 minutes
- Column (12) = Column (12) of previous time step + w \* [(Column (11) of previous time step + Column (11) of present time step) - (2 \* Column (12) of previous time step)] where w = routing constant = dt/(2Tc + dt) = 0.0641

(1) Time Increment	(2) Time (minute)	(3) Rainfall Distrib. (fraction)	(4) Incre. Rainfall (inches)	(5) Accumul. Rainfall (inches)	(6) PERVIOUS		(9) IMPERVIOUS		(10) Total Runoff (inches)	(11) Instant Flowrate (cfs)	(12) Design Flowrat e (cfs)
					Accum. Runoff (inches)	Incre. Runoff (inches)	Accum. Runoff (inches)	Incre. Runoff (inches)			
1	0	0	0	0	0	0	0	0	0	0.0	0.0
2	10	0.004	0.012	0.012	0.000	0.000	0.000	0.000	0.000	0.0	0.0
3	20	0.004	0.012	0.023	0.000	0.000	0.000	0.000	0.000	0.0	0.0
4	30	0.004	0.012	0.035	0.000	0.000	0.000	0.000	0.000	0.0	0.0
5	40	0.004	0.012	0.046	0.000	0.000	0.000	0.000	0.000	0.0	0.0
6	50	0.004	0.012	0.058	0.000	0.000	0.001	0.001	0.000	0.0	0.0
7	60	0.004	0.012	0.070	0.000	0.000	0.004	0.002	0.000	0.0	0.0
8	70	0.004	0.012	0.081	0.000	0.000	0.007	0.003	0.000	0.0	0.0
9	80	0.004	0.012	0.093	0.000	0.000	0.011	0.004	0.000	0.0	0.0
10	90	0.004	0.012	0.104	0.000	0.000	0.015	0.005	0.000	0.0	0.0
11	100	0.004	0.012	0.116	0.000	0.000	0.020	0.005	0.000	0.0	0.0
12	110	0.005	0.015	0.131	0.000	0.000	0.027	0.007	0.000	0.0	0.0
13	120	0.005	0.015	0.145	0.000	0.000	0.035	0.008	0.000	0.0	0.0
14	130	0.005	0.015	0.160	0.000	0.000	0.044	0.008	0.000	0.0	0.0
15	140	0.005	0.015	0.174	0.000	0.000	0.053	0.009	0.000	0.0	0.0
16	150	0.005	0.015	0.189	0.000	0.000	0.062	0.009	0.000	0.0	0.0
17	160	0.005	0.015	0.203	0.000	0.000	0.072	0.010	0.000	0.0	0.0
18	170	0.006	0.017	0.220	0.000	0.000	0.084	0.012	0.000	0.0	0.0
19	180	0.006	0.017	0.238	0.000	0.000	0.097	0.013	0.000	0.0	0.0
20	190	0.006	0.017	0.255	0.000	0.000	0.110	0.013	0.000	0.0	0.0
21	200	0.006	0.017	0.273	0.000	0.000	0.123	0.013	0.000	0.0	0.0
22	210	0.006	0.017	0.290	0.000	0.000	0.137	0.014	0.000	0.0	0.0
23	220	0.006	0.017	0.307	0.000	0.000	0.151	0.014	0.000	0.0	0.0
24	230	0.007	0.020	0.328	0.000	0.000	0.168	0.017	0.000	0.0	0.0
25	240	0.007	0.020	0.348	0.000	0.000	0.185	0.017	0.000	0.0	0.0
26	250	0.007	0.020	0.368	0.000	0.000	0.202	0.017	0.000	0.0	0.0
27	260	0.007	0.020	0.389	0.000	0.000	0.219	0.017	0.000	0.0	0.0
28	270	0.007	0.020	0.409	0.000	0.000	0.237	0.018	0.000	0.0	0.0
29	280	0.007	0.020	0.429	0.000	0.000	0.255	0.018	0.000	0.0	0.0
30	290	0.008	0.024	0.453	0.000	0.000	0.276	0.021	0.000	0.0	0.0
31	300	0.008	0.024	0.477	0.000	0.000	0.297	0.021	0.000	0.0	0.0
32	310	0.008	0.024	0.501	0.000	0.000	0.318	0.021	0.000	0.0	0.0
33	320	0.008	0.024	0.524	0.000	0.000	0.340	0.022	0.000	0.0	0.0
34	330	0.008	0.024	0.548	0.000	0.000	0.362	0.022	0.000	0.0	0.0
35	340	0.008	0.024	0.572	0.000	0.000	0.384	0.022	0.000	0.0	0.0
36	350	0.010	0.028	0.599	0.000	0.000	0.409	0.026	0.000	0.0	0.0
37	360	0.010	0.028	0.627	0.000	0.000	0.435	0.026	0.000	0.0	0.0
38	370	0.010	0.028	0.655	0.000	0.000	0.461	0.026	0.000	0.0	0.0

(1) Time Increment	(2) Time (minute)	(3) Rainfall Distrib. (fraction)	(4) Incre. Rainfall (inches)	(5) Accumul. Rainfall (inches)	(6) PERVIOUS		(8) IMPERVIOUS		(10) Total Runoff (inches)	(11) Instant Flowrate (cfs)	(12) Design Flowrat e (cfs)
					Accum. Runoff (inches)	Incre. Runoff (inches)	Accum. Runoff (inches)	Incre. Runoff (inches)			
39	380	0.010	0.028	0.682	0.000	0.000	0.486	0.026	0.000	0.0	0.0
40	390	0.010	0.028	0.710	0.000	0.000	0.512	0.026	0.000	0.0	0.0
41	400	0.010	0.028	0.737	0.000	0.000	0.539	0.026	0.000	0.0	0.0
42	410	0.013	0.039	0.776	0.001	0.001	0.575	0.037	0.001	0.1	0.0
43	420	0.013	0.039	0.815	0.003	0.002	0.613	0.037	0.002	0.1	0.0
44	430	0.013	0.039	0.854	0.006	0.003	0.650	0.037	0.003	0.2	0.0
45	440	0.018	0.052	0.906	0.011	0.005	0.700	0.050	0.005	0.3	0.1
46	450	0.018	0.052	0.958	0.017	0.006	0.750	0.050	0.006	0.4	0.1
47	460	0.034	0.099	1.057	0.032	0.015	0.846	0.096	0.015	0.9	0.2
48	470	0.054	0.157	1.213	0.065	0.032	0.999	0.153	0.032	2.0	0.3
49	480	0.027	0.078	1.292	0.085	0.020	1.075	0.077	0.020	1.2	0.5
50	490	0.018	0.052	1.344	0.099	0.014	1.127	0.051	0.014	0.9	0.6
51	500	0.013	0.039	1.383	0.110	0.011	1.165	0.038	0.011	0.7	0.6
52	510	0.013	0.039	1.422	0.122	0.012	1.203	0.038	0.012	0.7	0.6
53	520	0.013	0.039	1.460	0.134	0.012	1.241	0.038	0.012	0.7	0.6
54	530	0.009	0.026	1.486	0.143	0.008	1.266	0.025	0.008	0.5	0.6
55	540	0.009	0.026	1.511	0.151	0.009	1.291	0.025	0.009	0.5	0.6
56	550	0.009	0.026	1.537	0.160	0.009	1.317	0.025	0.009	0.5	0.6
57	560	0.009	0.026	1.563	0.169	0.009	1.342	0.025	0.009	0.5	0.6
58	570	0.009	0.026	1.588	0.178	0.009	1.367	0.025	0.009	0.6	0.6
59	580	0.009	0.026	1.614	0.188	0.009	1.392	0.025	0.009	0.6	0.6
60	590	0.009	0.026	1.639	0.197	0.010	1.417	0.025	0.010	0.6	0.6
61	600	0.009	0.026	1.665	0.207	0.010	1.442	0.025	0.010	0.6	0.6
62	610	0.009	0.026	1.690	0.217	0.010	1.468	0.025	0.010	0.6	0.6
63	620	0.009	0.026	1.716	0.227	0.010	1.493	0.025	0.010	0.6	0.6
64	630	0.009	0.026	1.741	0.237	0.010	1.518	0.025	0.010	0.6	0.6
65	640	0.009	0.026	1.767	0.247	0.010	1.543	0.025	0.010	0.6	0.6
66	650	0.007	0.021	1.788	0.256	0.009	1.564	0.021	0.009	0.5	0.6
67	660	0.007	0.021	1.808	0.265	0.009	1.585	0.021	0.009	0.5	0.6
68	670	0.007	0.021	1.829	0.274	0.009	1.605	0.021	0.009	0.5	0.6
69	680	0.007	0.021	1.850	0.283	0.009	1.626	0.021	0.009	0.5	0.6
70	690	0.007	0.021	1.871	0.292	0.009	1.647	0.021	0.009	0.5	0.6
71	700	0.007	0.021	1.892	0.301	0.009	1.667	0.021	0.009	0.6	0.6
72	710	0.007	0.021	1.913	0.310	0.009	1.688	0.021	0.009	0.6	0.6
73	720	0.007	0.021	1.934	0.319	0.009	1.709	0.021	0.009	0.6	0.6
74	730	0.007	0.021	1.955	0.329	0.009	1.729	0.021	0.009	0.6	0.6
75	740	0.007	0.021	1.975	0.338	0.010	1.750	0.021	0.010	0.6	0.6
76	750	0.007	0.021	1.996	0.348	0.010	1.771	0.021	0.010	0.6	0.6
77	760	0.007	0.021	2.017	0.358	0.010	1.791	0.021	0.010	0.6	0.6
78	770	0.006	0.017	2.034	0.366	0.008	1.808	0.016	0.008	0.5	0.6
79	780	0.006	0.017	2.050	0.374	0.008	1.824	0.016	0.008	0.5	0.6
80	790	0.006	0.017	2.067	0.382	0.008	1.841	0.016	0.008	0.5	0.5
81	800	0.006	0.017	2.083	0.389	0.008	1.857	0.016	0.008	0.5	0.5
82	810	0.006	0.017	2.100	0.398	0.008	1.873	0.016	0.008	0.5	0.5
83	820	0.006	0.017	2.116	0.406	0.008	1.890	0.016	0.008	0.5	0.5
84	830	0.006	0.017	2.133	0.414	0.008	1.906	0.016	0.008	0.5	0.5
85	840	0.006	0.017	2.149	0.422	0.008	1.923	0.016	0.008	0.5	0.5
86	850	0.006	0.017	2.166	0.430	0.008	1.939	0.016	0.008	0.5	0.5
87	860	0.006	0.017	2.183	0.439	0.008	1.955	0.016	0.008	0.5	0.5
88	870	0.006	0.017	2.199	0.447	0.008	1.972	0.016	0.008	0.5	0.5
89	880	0.006	0.017	2.216	0.455	0.008	1.988	0.016	0.008	0.5	0.5
90	890	0.005	0.015	2.230	0.463	0.007	2.003	0.014	0.007	0.4	0.5
91	900	0.005	0.015	2.245	0.470	0.007	2.017	0.014	0.007	0.5	0.5
92	910	0.005	0.015	2.259	0.478	0.008	2.031	0.014	0.008	0.5	0.5
93	920	0.005	0.015	2.274	0.485	0.008	2.046	0.014	0.008	0.5	0.5
94	930	0.005	0.015	2.288	0.493	0.008	2.060	0.014	0.008	0.5	0.5
95	940	0.005	0.015	2.303	0.501	0.008	2.075	0.014	0.008	0.5	0.5

(1) Time Increment	(2) Time (minute)	(3) Rainfall Distrib. (fraction)	(4) Incre. Rainfall (inches)	(5) Accumul. Rainfall (inches)	(6) PERVIOUS		(8) IMPERVIOUS		(10) Total Runoff (inches)	(11) Instant Flowrate (cfs)	(12) Design Flowrate (cfs)
					Accum. Runoff (inches)	Incre. Runoff (inches)	Accum. Runoff (inches)	Incre. Runoff (inches)			
96	950	0.005	0.015	2.317	0.508	0.008	2.089	0.014	0.008	0.5	0.5
97	960	0.005	0.015	2.332	0.516	0.008	2.103	0.014	0.008	0.5	0.5
98	970	0.005	0.015	2.346	0.524	0.008	2.118	0.014	0.008	0.5	0.5
99	980	0.005	0.015	2.361	0.532	0.008	2.132	0.014	0.008	0.5	0.5
100	990	0.005	0.015	2.375	0.539	0.008	2.147	0.014	0.008	0.5	0.5
101	1000	0.005	0.015	2.390	0.547	0.008	2.161	0.014	0.008	0.5	0.5
102	1010	0.004	0.012	2.401	0.554	0.006	2.173	0.012	0.006	0.4	0.5
103	1020	0.004	0.012	2.413	0.560	0.006	2.184	0.012	0.006	0.4	0.5
104	1030	0.004	0.012	2.424	0.566	0.006	2.196	0.012	0.006	0.4	0.4
105	1040	0.004	0.012	2.436	0.573	0.006	2.207	0.012	0.006	0.4	0.4
106	1050	0.004	0.012	2.448	0.579	0.006	2.219	0.012	0.006	0.4	0.4
107	1060	0.004	0.012	2.459	0.585	0.006	2.230	0.012	0.006	0.4	0.4
108	1070	0.004	0.012	2.471	0.592	0.006	2.242	0.012	0.006	0.4	0.4
109	1080	0.004	0.012	2.482	0.598	0.006	2.253	0.012	0.006	0.4	0.4
110	1090	0.004	0.012	2.494	0.605	0.007	2.265	0.012	0.007	0.4	0.4
111	1100	0.004	0.012	2.506	0.611	0.007	2.276	0.012	0.007	0.4	0.4
112	1110	0.004	0.012	2.517	0.618	0.007	2.288	0.012	0.007	0.4	0.4
113	1120	0.004	0.012	2.529	0.625	0.007	2.299	0.012	0.007	0.4	0.4
114	1130	0.004	0.012	2.540	0.631	0.007	2.311	0.012	0.007	0.4	0.4
115	1140	0.004	0.012	2.552	0.638	0.007	2.322	0.012	0.007	0.4	0.4
116	1150	0.004	0.012	2.564	0.644	0.007	2.334	0.012	0.007	0.4	0.4
117	1160	0.004	0.012	2.575	0.651	0.007	2.346	0.012	0.007	0.4	0.4
118	1170	0.004	0.012	2.587	0.658	0.007	2.357	0.012	0.007	0.4	0.4
119	1180	0.004	0.012	2.598	0.664	0.007	2.369	0.012	0.007	0.4	0.4
120	1190	0.004	0.012	2.610	0.671	0.007	2.380	0.012	0.007	0.4	0.4
121	1200	0.004	0.012	2.622	0.678	0.007	2.392	0.012	0.007	0.4	0.4
122	1210	0.004	0.012	2.633	0.685	0.007	2.403	0.012	0.007	0.4	0.4
123	1220	0.004	0.012	2.645	0.691	0.007	2.415	0.012	0.007	0.4	0.4
124	1230	0.004	0.012	2.656	0.698	0.007	2.426	0.012	0.007	0.4	0.4
125	1240	0.004	0.012	2.668	0.705	0.007	2.438	0.012	0.007	0.4	0.4
126	1250	0.004	0.012	2.680	0.712	0.007	2.449	0.012	0.007	0.4	0.4
127	1260	0.004	0.012	2.691	0.719	0.007	2.461	0.012	0.007	0.4	0.4
128	1270	0.004	0.012	2.703	0.726	0.007	2.472	0.012	0.007	0.4	0.4
129	1280	0.004	0.012	2.714	0.732	0.007	2.484	0.012	0.007	0.4	0.4
130	1290	0.004	0.012	2.726	0.739	0.007	2.496	0.012	0.007	0.4	0.4
131	1300	0.004	0.012	2.738	0.746	0.007	2.507	0.012	0.007	0.4	0.4
132	1310	0.004	0.012	2.749	0.753	0.007	2.519	0.012	0.007	0.4	0.4
133	1320	0.004	0.012	2.761	0.760	0.007	2.530	0.012	0.007	0.4	0.4
134	1330	0.004	0.012	2.772	0.767	0.007	2.542	0.012	0.007	0.4	0.4
135	1340	0.004	0.012	2.784	0.774	0.007	2.553	0.012	0.007	0.4	0.4
136	1350	0.004	0.012	2.796	0.781	0.007	2.565	0.012	0.007	0.4	0.4
137	1360	0.004	0.012	2.807	0.788	0.007	2.576	0.012	0.007	0.4	0.4
138	1370	0.004	0.012	2.819	0.795	0.007	2.588	0.012	0.007	0.4	0.4
139	1380	0.004	0.012	2.830	0.803	0.007	2.599	0.012	0.007	0.4	0.4
140	1390	0.004	0.012	2.842	0.810	0.007	2.611	0.012	0.007	0.4	0.4
141	1400	0.004	0.012	2.854	0.817	0.007	2.623	0.012	0.007	0.4	0.4
142	1410	0.004	0.012	2.865	0.824	0.007	2.634	0.012	0.007	0.4	0.4
143	1420	0.004	0.012	2.877	0.831	0.007	2.646	0.012	0.007	0.4	0.4
144	1430	0.004	0.012	2.888	0.838	0.007	2.657	0.012	0.007	0.4	0.4
145	1440	0.004	0.012	2.900	0.845	0.007	2.669	0.012	0.007	0.4	0.4



**Table 2.7**  
**SBUH Values for Developed Site Condition**

Given: Area = 10 acres    P = 2.9 inches (10-yr., 24-hr. event)    dt = 10 minutes  
 PERVIOUS AREA:    Area = 6.1 acres    CN = 89    S = 1.235955    0.2S = 0.25  
 IMPERVIOUS AREA:    Area = 3.9 acres    CN = 98    S = 0.204082    0.2S = 0.04  
 Tc = 28 minutes    w = 0.151515    where S = potential maximum natural detention (as defined earlier)

- Column (1) = Time Increment Column (2) = Time (min)
- Column (3) = Type IA Storm Distribution
- Column (4) = Column (3) \* P
- Column (5) = Accumulated sum of Column (4)
- Column (6) = If (P < 0.2S) = 0, If (P > 0.2S) = (Column (5) - 0.2S)^2 / (Column (5) + 0.8S), where the PERVIOUS AREA S value is used
- Column (7) = Column (6) of the present step - Column (6) of the previous step
- Column (8) = Same as Column (6) except use IMPERVIOUS AREA S value
- Column (9) = Column (8) of the present step - Column (8) of the previous step
- Column (10) = (PERVIOUS AREA/TOTAL AREA)\*Column (7)+(IMPERVIOUS AREA/TOTAL AREA)\*Column (9)
- Column (11) = (60.5\*Column (10)\*Total Area)/dt, where dt = 10 or 60 minutes
- Column (12) = Column (12) of previous time step + w \* [(Column (11) of previous time step + Column (11) of present time step) - (2 \* Column (12) of previous time step)] where w = routing constant = dt/(2Tc + dt) = 0.0641

(1) Time Increment t	(2) Time (minute)	(3) Rainfall Distrib. (fraction)	(4) Incre. Rainfall (inches)	(5) Accumul. Rainfall (inches)	PERVIOUS		IMPERVIOUS		(10) Total Runoff (inches)	(11) Instant Flowrate (cfs)	(12) Design Flowrate (cfs)
					(6) Accum. Runoff (inches)	(7) Incre. Runoff (inches)	(8) Accum. Runoff (inches)	(9) Incre. Runoff (inches)			
1	0	0	0	0	0	0	0	0	0	0.0	0.0
2	10	0.004	0.012	0.012	0.000	0.000	0.000	0.000	0.000	0.0	0.0
3	20	0.004	0.012	0.023	0.000	0.000	0.000	0.000	0.000	0.0	0.0
4	30	0.004	0.012	0.035	0.000	0.000	0.000	0.000	0.000	0.0	0.0
5	40	0.004	0.012	0.046	0.000	0.000	0.000	0.000	0.000	0.0	0.0
6	50	0.004	0.012	0.058	0.000	0.000	0.001	0.001	0.000	0.0	0.0
7	60	0.004	0.012	0.070	0.000	0.000	0.004	0.002	0.001	0.1	0.0
8	70	0.004	0.012	0.081	0.000	0.000	0.007	0.003	0.001	0.1	0.0
9	80	0.004	0.012	0.093	0.000	0.000	0.011	0.004	0.002	0.1	0.0
10	90	0.004	0.012	0.104	0.000	0.000	0.015	0.005	0.002	0.1	0.1
11	100	0.004	0.012	0.116	0.000	0.000	0.020	0.005	0.002	0.1	0.1
12	110	0.005	0.015	0.131	0.000	0.000	0.027	0.007	0.003	0.2	0.1
13	120	0.005	0.015	0.145	0.000	0.000	0.035	0.008	0.003	0.2	0.1
14	130	0.005	0.015	0.160	0.000	0.000	0.044	0.008	0.003	0.2	0.1
15	140	0.005	0.015	0.174	0.000	0.000	0.053	0.009	0.003	0.2	0.2
16	150	0.005	0.015	0.189	0.000	0.000	0.062	0.009	0.004	0.2	0.2
17	160	0.005	0.015	0.203	0.000	0.000	0.072	0.010	0.004	0.2	0.2
18	170	0.006	0.017	0.220	0.000	0.000	0.084	0.012	0.005	0.3	0.2
19	180	0.006	0.017	0.238	0.000	0.000	0.097	0.013	0.005	0.3	0.2
20	190	0.006	0.017	0.255	0.000	0.000	0.110	0.013	0.005	0.3	0.3
21	200	0.006	0.017	0.273	0.001	0.000	0.123	0.013	0.006	0.3	0.3
22	210	0.006	0.017	0.290	0.001	0.001	0.137	0.014	0.006	0.4	0.3
23	220	0.006	0.017	0.307	0.003	0.001	0.151	0.014	0.006	0.4	0.3
24	230	0.007	0.020	0.328	0.005	0.002	0.168	0.017	0.008	0.5	0.4
25	240	0.007	0.020	0.348	0.008	0.003	0.185	0.017	0.008	0.5	0.4
26	250	0.007	0.020	0.368	0.011	0.003	0.202	0.017	0.009	0.5	0.4
27	260	0.007	0.020	0.389	0.015	0.004	0.219	0.017	0.009	0.5	0.5
28	270	0.007	0.020	0.409	0.019	0.004	0.237	0.018	0.009	0.6	0.5
29	280	0.007	0.020	0.429	0.023	0.005	0.255	0.018	0.010	0.6	0.5
30	290	0.008	0.024	0.453	0.029	0.006	0.276	0.021	0.012	0.7	0.6
31	300	0.008	0.024	0.477	0.036	0.007	0.297	0.021	0.012	0.7	0.6
32	310	0.008	0.024	0.501	0.043	0.007	0.318	0.021	0.013	0.8	0.7
33	320	0.008	0.024	0.524	0.051	0.008	0.340	0.022	0.013	0.8	0.7
34	330	0.008	0.024	0.548	0.059	0.008	0.362	0.022	0.013	0.8	0.7
35	340	0.008	0.024	0.572	0.068	0.009	0.384	0.022	0.014	0.8	0.8
36	350	0.010	0.028	0.599	0.078	0.011	0.409	0.026	0.016	1.0	0.8
37	360	0.010	0.028	0.627	0.089	0.011	0.435	0.026	0.017	1.0	0.9
38	370	0.010	0.028	0.655	0.101	0.012	0.461	0.026	0.017	1.0	0.9

(1)	(2)	(3)	(4)	(5)	(6) PERVIOUS		(7) IMPERVIOUS		(10)	(11)	(12)
Time Increment	Time (minute)	Rainfall Distrib. (fraction)	Incr. Rainfall (inches)	Accumul. Rainfall (inches)	Accum. Runoff (inches)	Incr. Runoff (inches)	Accum. Runoff (inches)	Incr. Runoff (inches)	Total Runoff (inches)	Instant Flowrate (cfs)	Design Flowrate (cfs)
39	380	0.010	0.028	0.682	0.113	0.012	0.486	0.026	0.018	1.1	1.0
40	390	0.010	0.028	0.710	0.126	0.013	0.512	0.026	0.018	1.1	1.0
41	400	0.010	0.028	0.737	0.139	0.013	0.539	0.026	0.018	1.1	1.0
42	410	0.013	0.039	0.776	0.158	0.019	0.575	0.037	0.026	1.6	1.1
43	420	0.013	0.039	0.815	0.179	0.020	0.613	0.037	0.027	1.6	1.3
44	430	0.013	0.039	0.854	0.200	0.021	0.650	0.037	0.027	1.7	1.4
45	440	0.018	0.052	0.906	0.229	0.029	0.700	0.050	0.037	2.3	1.6
46	450	0.018	0.052	0.958	0.260	0.031	0.750	0.050	0.038	2.3	1.8
47	460	0.034	0.099	1.057	0.320	0.061	0.846	0.096	0.074	4.5	2.3
48	470	0.054	0.157	1.213	0.424	0.103	0.999	0.153	0.123	7.4	3.4
49	480	0.027	0.078	1.292	0.478	0.054	1.075	0.077	0.063	3.8	4.1
50	490	0.018	0.052	1.344	0.516	0.037	1.127	0.051	0.043	2.6	3.8
51	500	0.013	0.039	1.383	0.544	0.028	1.165	0.038	0.032	1.9	3.3
52	510	0.013	0.039	1.422	0.572	0.028	1.203	0.038	0.032	2.0	2.9
53	520	0.013	0.039	1.460	0.601	0.029	1.241	0.038	0.032	2.0	2.6
54	530	0.009	0.026	1.486	0.620	0.019	1.266	0.025	0.021	1.3	2.3
55	540	0.009	0.026	1.511	0.639	0.019	1.291	0.025	0.022	1.3	2.0
56	550	0.009	0.026	1.537	0.659	0.019	1.317	0.025	0.022	1.3	1.8
57	560	0.009	0.026	1.563	0.678	0.019	1.342	0.025	0.022	1.3	1.7
58	570	0.009	0.026	1.588	0.698	0.020	1.367	0.025	0.022	1.3	1.5
59	580	0.009	0.026	1.614	0.717	0.020	1.392	0.025	0.022	1.3	1.5
60	590	0.009	0.026	1.639	0.737	0.020	1.417	0.025	0.022	1.3	1.4
61	600	0.009	0.026	1.665	0.757	0.020	1.442	0.025	0.022	1.3	1.4
62	610	0.009	0.026	1.690	0.777	0.020	1.468	0.025	0.022	1.3	1.4
63	620	0.009	0.026	1.716	0.797	0.020	1.493	0.025	0.022	1.3	1.4
64	630	0.009	0.026	1.741	0.818	0.020	1.518	0.025	0.022	1.3	1.4
65	640	0.009	0.026	1.767	0.838	0.020	1.543	0.025	0.022	1.3	1.4
66	650	0.007	0.021	1.788	0.855	0.017	1.564	0.021	0.018	1.1	1.3
67	660	0.007	0.021	1.808	0.871	0.017	1.585	0.021	0.018	1.1	1.3
68	670	0.007	0.021	1.829	0.888	0.017	1.605	0.021	0.018	1.1	1.2
69	680	0.007	0.021	1.850	0.905	0.017	1.626	0.021	0.018	1.1	1.2
70	690	0.007	0.021	1.871	0.922	0.017	1.647	0.021	0.018	1.1	1.2
71	700	0.007	0.021	1.892	0.939	0.017	1.667	0.021	0.018	1.1	1.1
72	710	0.007	0.021	1.913	0.956	0.017	1.688	0.021	0.018	1.1	1.1
73	720	0.007	0.021	1.934	0.973	0.017	1.709	0.021	0.019	1.1	1.1
74	730	0.007	0.021	1.955	0.990	0.017	1.729	0.021	0.019	1.1	1.1
75	740	0.007	0.021	1.975	1.008	0.017	1.750	0.021	0.019	1.1	1.1
76	750	0.007	0.021	1.996	1.025	0.017	1.771	0.021	0.019	1.1	1.1
77	760	0.007	0.021	2.017	1.042	0.017	1.791	0.021	0.019	1.1	1.1
78	770	0.006	0.017	2.034	1.056	0.014	1.808	0.016	0.015	0.9	1.1
79	780	0.006	0.017	2.050	1.070	0.014	1.824	0.016	0.015	0.9	1.0
80	790	0.006	0.017	2.067	1.084	0.014	1.841	0.016	0.015	0.9	1.0
81	800	0.006	0.017	2.083	1.097	0.014	1.857	0.016	0.015	0.9	1.0
82	810	0.006	0.017	2.100	1.111	0.014	1.873	0.016	0.015	0.9	0.9
83	820	0.006	0.017	2.116	1.125	0.014	1.890	0.016	0.015	0.9	0.9
84	830	0.006	0.017	2.133	1.139	0.014	1.906	0.016	0.015	0.9	0.9
85	840	0.006	0.017	2.149	1.153	0.014	1.923	0.016	0.015	0.9	0.9
86	850	0.006	0.017	2.166	1.167	0.014	1.939	0.016	0.015	0.9	0.9
87	860	0.006	0.017	2.183	1.181	0.014	1.955	0.016	0.015	0.9	0.9
88	870	0.006	0.017	2.199	1.195	0.014	1.972	0.016	0.015	0.9	0.9
89	880	0.006	0.017	2.216	1.209	0.014	1.988	0.016	0.015	0.9	0.9
90	890	0.005	0.015	2.230	1.222	0.012	2.003	0.014	0.013	0.8	0.9
91	900	0.005	0.015	2.245	1.234	0.012	2.017	0.014	0.013	0.8	0.9
92	910	0.005	0.015	2.259	1.246	0.012	2.031	0.014	0.013	0.8	0.8
93	920	0.005	0.015	2.274	1.259	0.012	2.046	0.014	0.013	0.8	0.8
94	930	0.005	0.015	2.288	1.271	0.012	2.060	0.014	0.013	0.8	0.8
95	940	0.005	0.015	2.303	1.284	0.012	2.075	0.014	0.013	0.8	0.8

(1)	(2)	(3)	(4)	(5)	(6) PERVIOUS		(8) IMPERVIOUS		(10)	(11)	(12) Design
Time Increment	Time (minute)	Rainfall Distrib. (fraction)	Incr. Rainfall (inches)	Accumul. Rainfall (inches)	Accum. Runoff (inches)	Incr. Runoff (inches)	Accum. Runoff (inches)	Incr. Runoff (inches)	Total Runoff (inches)	Instant Flowrate (cfs)	Flowrate (cfs)
96	950	0.005	0.015	2.317	1.296	0.012	2.089	0.014	0.013	0.8	0.8
97	960	0.005	0.015	2.332	1.309	0.012	2.103	0.014	0.013	0.8	0.8
98	970	0.005	0.015	2.346	1.321	0.012	2.118	0.014	0.013	0.8	0.8
99	980	0.005	0.015	2.361	1.334	0.013	2.132	0.014	0.013	0.8	0.8
100	990	0.005	0.015	2.375	1.346	0.013	2.147	0.014	0.013	0.8	0.8
101	1000	0.005	0.015	2.390	1.359	0.013	2.161	0.014	0.013	0.8	0.8
102	1010	0.004	0.012	2.401	1.369	0.010	2.173	0.012	0.011	0.6	0.8
103	1020	0.004	0.012	2.413	1.379	0.010	2.184	0.012	0.011	0.6	0.7
104	1030	0.004	0.012	2.424	1.389	0.010	2.196	0.012	0.011	0.6	0.7
105	1040	0.004	0.012	2.436	1.399	0.010	2.207	0.012	0.011	0.6	0.7
106	1050	0.004	0.012	2.448	1.409	0.010	2.219	0.012	0.011	0.6	0.7
107	1060	0.004	0.012	2.459	1.419	0.010	2.230	0.012	0.011	0.6	0.7
108	1070	0.004	0.012	2.471	1.429	0.010	2.242	0.012	0.011	0.6	0.7
109	1080	0.004	0.012	2.482	1.439	0.010	2.253	0.012	0.011	0.6	0.7
110	1090	0.004	0.012	2.494	1.449	0.010	2.265	0.012	0.011	0.6	0.7
111	1100	0.004	0.012	2.506	1.460	0.010	2.276	0.012	0.011	0.6	0.7
112	1110	0.004	0.012	2.517	1.470	0.010	2.288	0.012	0.011	0.6	0.6
113	1120	0.004	0.012	2.529	1.480	0.010	2.299	0.012	0.011	0.6	0.6
114	1130	0.004	0.012	2.540	1.490	0.010	2.311	0.012	0.011	0.6	0.6
115	1140	0.004	0.012	2.552	1.500	0.010	2.322	0.012	0.011	0.6	0.6
116	1150	0.004	0.012	2.564	1.510	0.010	2.334	0.012	0.011	0.6	0.6
117	1160	0.004	0.012	2.575	1.521	0.010	2.346	0.012	0.011	0.6	0.6
118	1170	0.004	0.012	2.587	1.531	0.010	2.357	0.012	0.011	0.6	0.6
119	1180	0.004	0.012	2.598	1.541	0.010	2.369	0.012	0.011	0.6	0.6
120	1190	0.004	0.012	2.610	1.551	0.010	2.380	0.012	0.011	0.6	0.6
121	1200	0.004	0.012	2.622	1.562	0.010	2.392	0.012	0.011	0.6	0.6
122	1210	0.004	0.012	2.633	1.572	0.010	2.403	0.012	0.011	0.7	0.6
123	1220	0.004	0.012	2.645	1.582	0.010	2.415	0.012	0.011	0.7	0.6
124	1230	0.004	0.012	2.656	1.592	0.010	2.426	0.012	0.011	0.7	0.7
125	1240	0.004	0.012	2.668	1.603	0.010	2.438	0.012	0.011	0.7	0.7
126	1250	0.004	0.012	2.680	1.613	0.010	2.449	0.012	0.011	0.7	0.7
127	1260	0.004	0.012	2.691	1.623	0.010	2.461	0.012	0.011	0.7	0.7
128	1270	0.004	0.012	2.703	1.633	0.010	2.472	0.012	0.011	0.7	0.7
129	1280	0.004	0.012	2.714	1.644	0.010	2.484	0.012	0.011	0.7	0.7
130	1290	0.004	0.012	2.726	1.654	0.010	2.496	0.012	0.011	0.7	0.7
131	1300	0.004	0.012	2.738	1.664	0.010	2.507	0.012	0.011	0.7	0.7
132	1310	0.004	0.012	2.749	1.675	0.010	2.519	0.012	0.011	0.7	0.7
133	1320	0.004	0.012	2.761	1.685	0.010	2.530	0.012	0.011	0.7	0.7
134	1330	0.004	0.012	2.772	1.695	0.010	2.542	0.012	0.011	0.7	0.7
135	1340	0.004	0.012	2.784	1.706	0.010	2.553	0.012	0.011	0.7	0.7
136	1350	0.004	0.012	2.796	1.716	0.010	2.565	0.012	0.011	0.7	0.7
137	1360	0.004	0.012	2.807	1.726	0.010	2.576	0.012	0.011	0.7	0.7
138	1370	0.004	0.012	2.819	1.737	0.010	2.588	0.012	0.011	0.7	0.7
139	1380	0.004	0.012	2.830	1.747	0.010	2.599	0.012	0.011	0.7	0.7
140	1390	0.004	0.012	2.842	1.758	0.010	2.611	0.012	0.011	0.7	0.7
141	1400	0.004	0.012	2.854	1.768	0.010	2.623	0.012	0.011	0.7	0.7
142	1410	0.004	0.012	2.865	1.778	0.010	2.634	0.012	0.011	0.7	0.7
143	1420	0.004	0.012	2.877	1.789	0.010	2.646	0.012	0.011	0.7	0.7
144	1430	0.004	0.012	2.888	1.799	0.010	2.657	0.012	0.011	0.7	0.7
145	1440	0.004	0.012	2.900	1.810	0.010	2.669	0.012	0.011	0.7	0.7

Elevation Feet	Stage Feet	Outflow*	Storage	2S cfs	O+2S cfs
		O cfs	S cfs**		
71	0	0.00	0.000	0.000	0.00
72	1	1.74	0.694	1.389	3.13
73	2	2.46	2.514	5.028	7.48
74	3	3.01	5.306	10.611	13.62
75	4	3.47	8.903	17.806	21.28
76	5	3.88	13.556	27.111	30.99

\* From 8" orifice, stage-discharge relationship  $[Q = (\text{orifice area})(0.62)\sqrt{2gh}]$ , where h = stage].

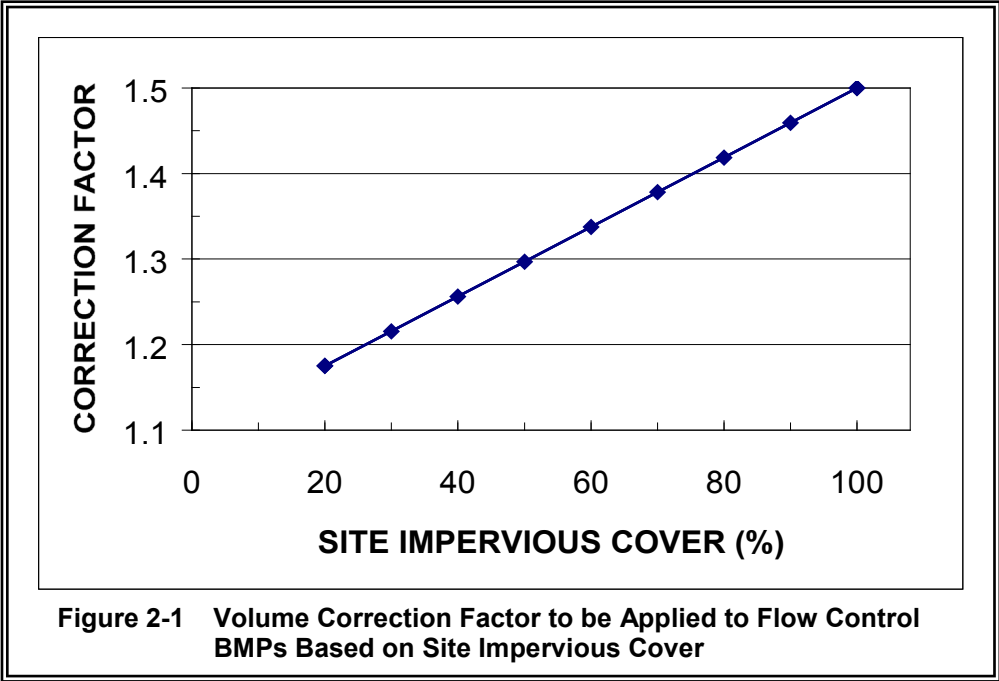
\*\* From stage-storage curve, Figure 2.5, storage volume converted to cfs for 60-minute time intervals.

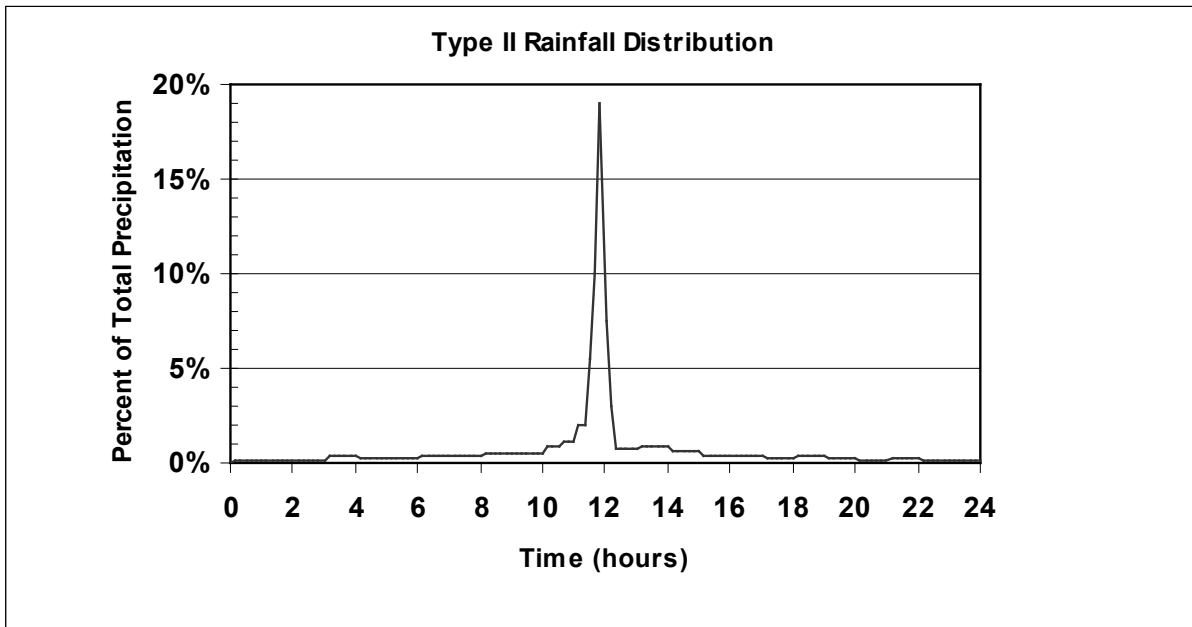
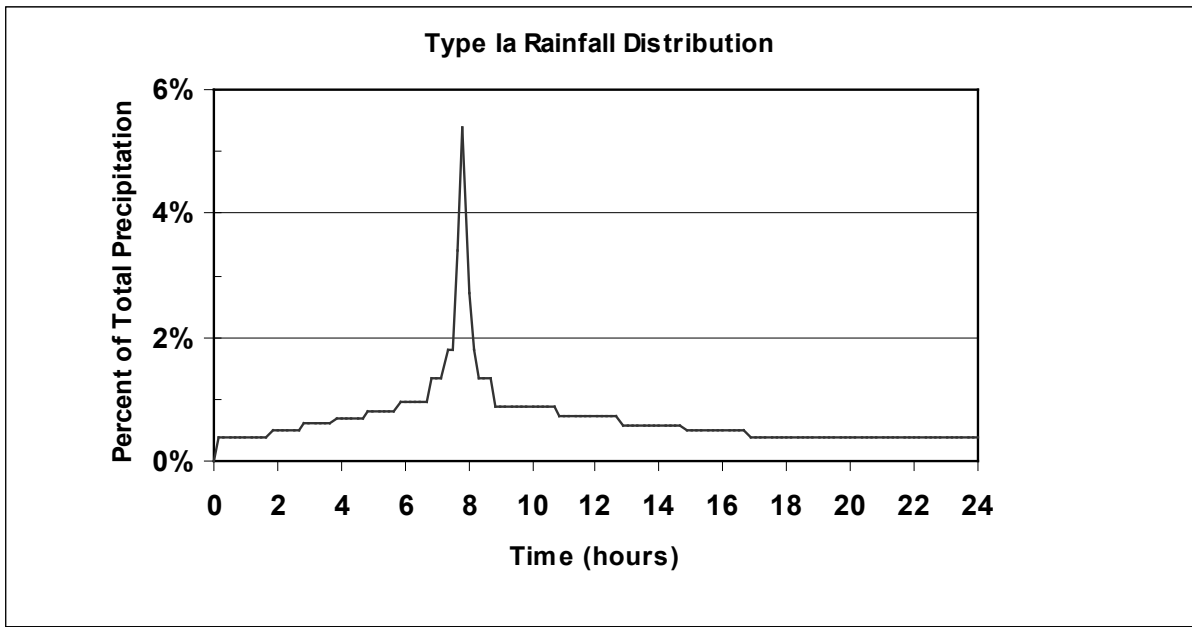
Time Periods	(1) $I_n$ (cfs)	(2) $I_{n+1}$ (cfs)	(3) $2S_n$ (cfs)	(4) $I_n + I_{n+1} + 2S_n$ (cfs)	(5) $O_n$ (cfs)	(6) $O_{n+1} + 2S_{n+1}$ (cfs)	(7) Stage (ft)	(8) Elevation (ft)
1	0.00	2.34	0.00	2.34	0.00	2.34	0.00	71.00
2	2.34	4.64	1.04	8.02	1.30	6.72	0.75	71.75
3	4.64	6.94	4.39	15.97	2.33	13.64	1.82	72.82
4	6.94	5.55	10.63	23.12	3.01	20.11	3.00	74.00
5	5.55	4.18	16.71	26.44	3.40	23.04	3.85	74.85
6	4.18	2.79	19.49	26.46	3.55	22.91	4.18	75.18*
7	2.79	1.39	19.37	23.55	3.54	20.01	4.17	75.17
8	1.39	0.00	16.61	18.00	3.40	14.60	3.83	74.83
9	0.00	0.00	11.54	11.54	3.07	8.47	3.13	74.13
10	0.00	0.00	5.92	5.92	2.54	3.38	2.16	73.16
11	0.00	0.00	1.60	1.60	1.78	0.00	1.06	72.06
12	0.00	0.00	0.00	0.00	0.00	0.00	0.00	71.00

\*Maximum floodplain elevation

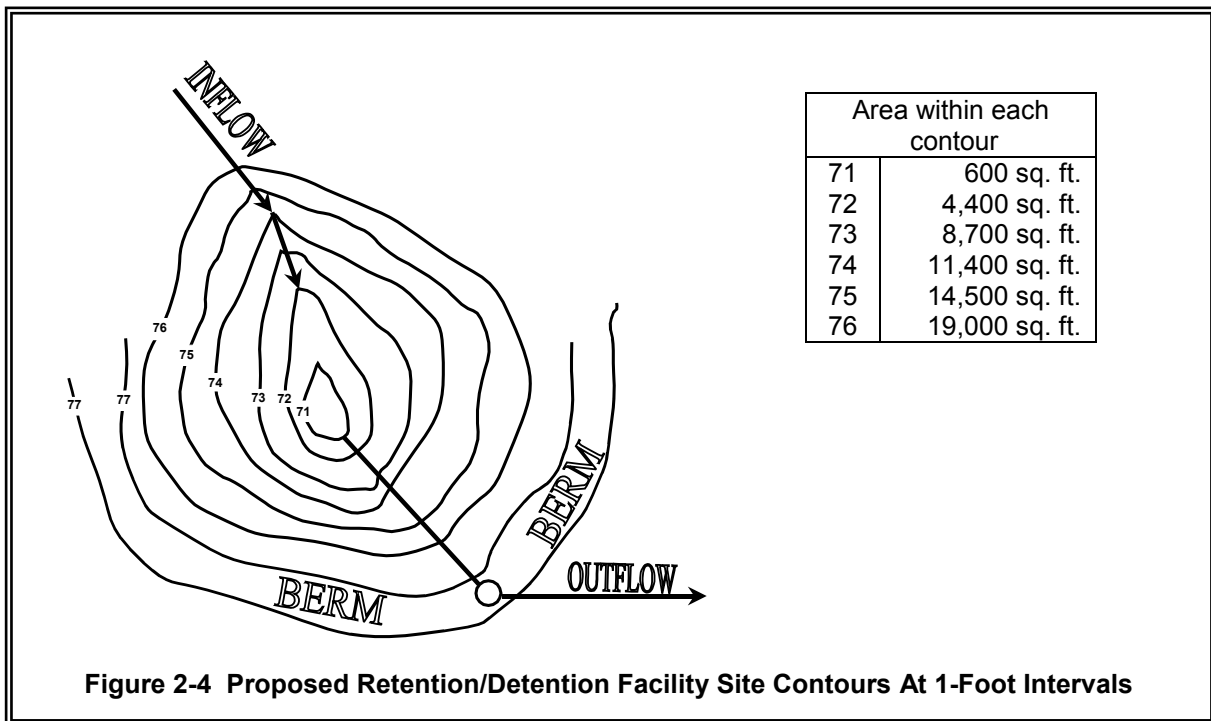
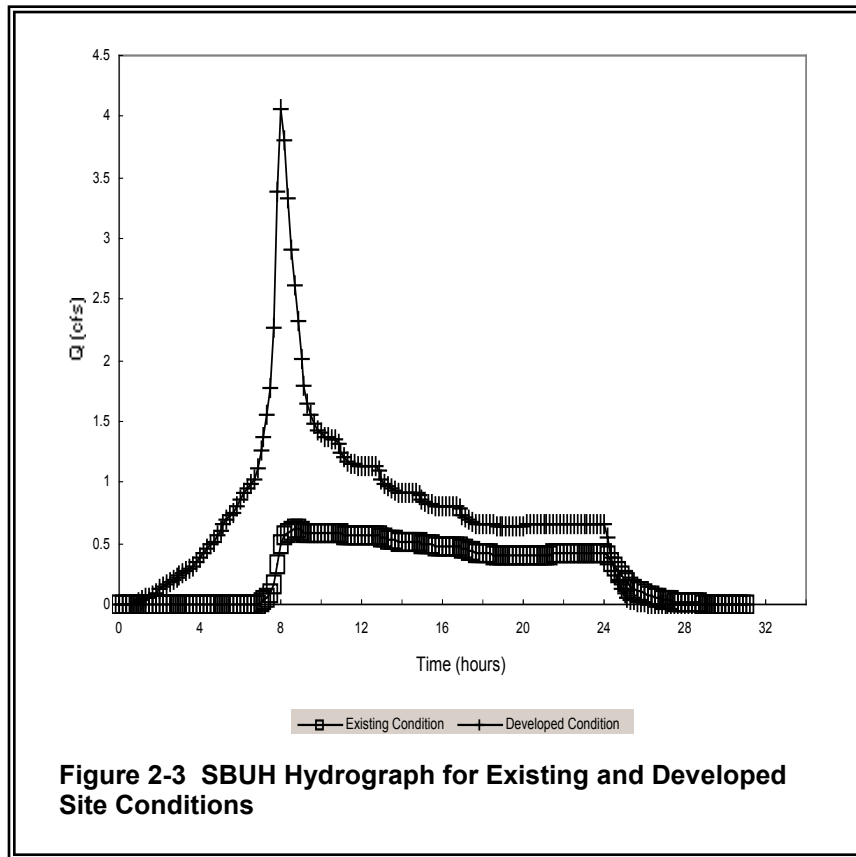
<b>Table 2.10</b>	
<b>Stage – Storage Table</b>	
<b>Stage, h*</b>	<b>Storage, S(h)</b>
0.0	0.0
0.5	2,217
1.0	4,637
1.5	7,271
2.0	10,128
2.5	13,215
3.0	16,543
3.5	20,120
4.0	23,955

<b>Table 2.11</b>			
<b>Closed Depression Summary Table</b>			
<b>Case No.</b>	<b>Check for Pre-development Overflow Condition</b>	<b>Overflow</b>	<b>Post-development Overflow Requirement</b>
1	100-year, 7-day	None	None
2	100-year, 7-day AND 100-year, 24-hour	Some  None	Match the pre-development overflow
3	100-year, 7-day AND 100-year, 24-hour	Some  Some	Meet the runoff duration standard in Volume 1

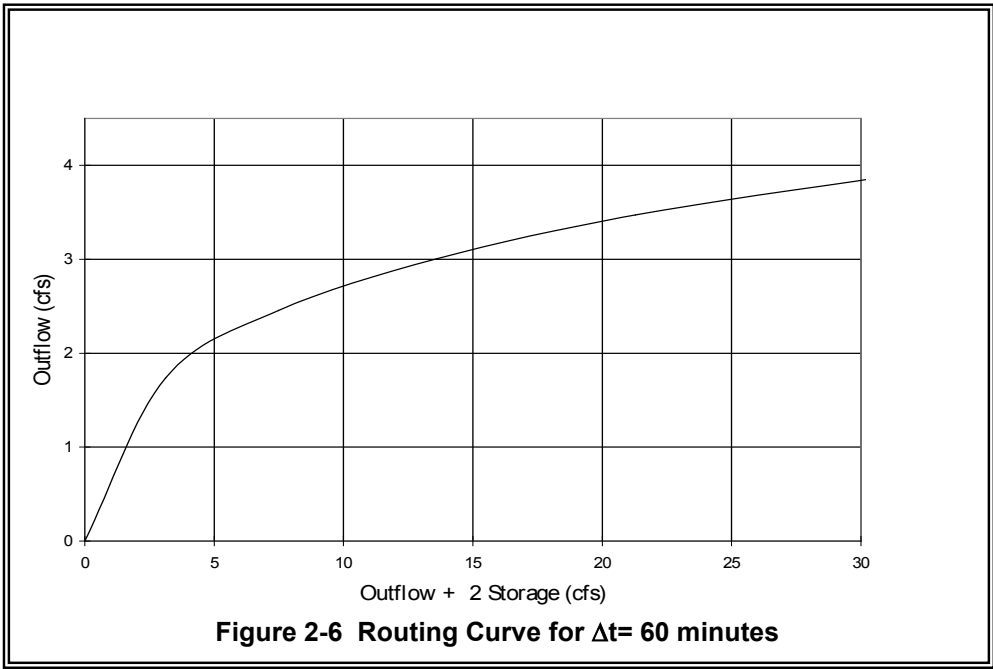
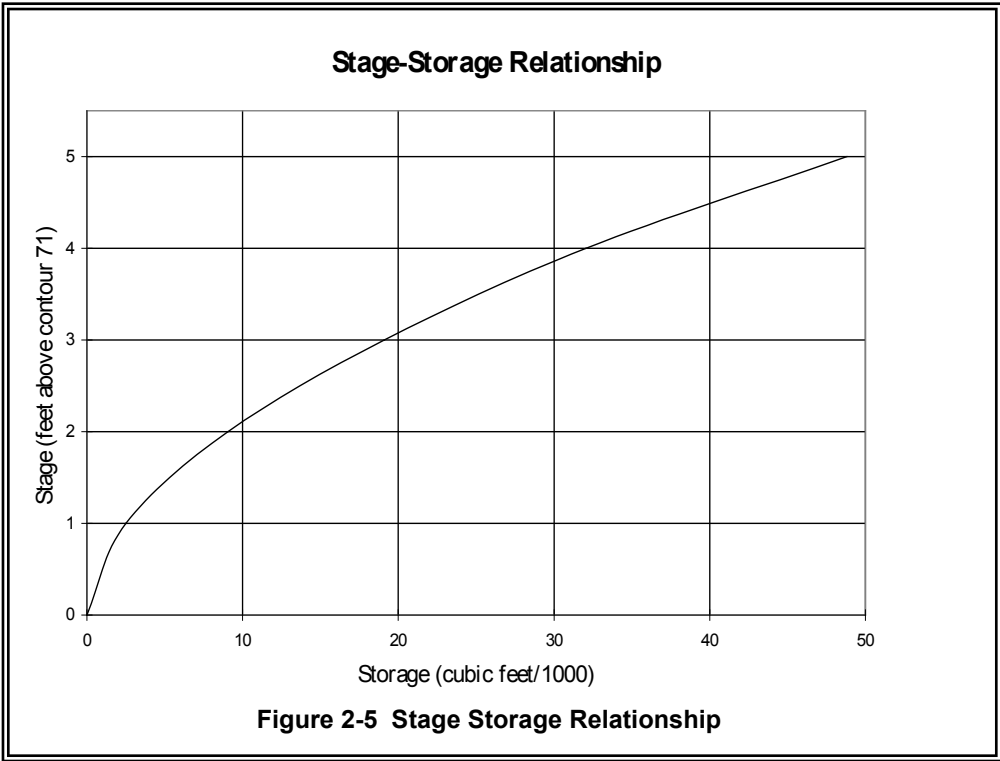


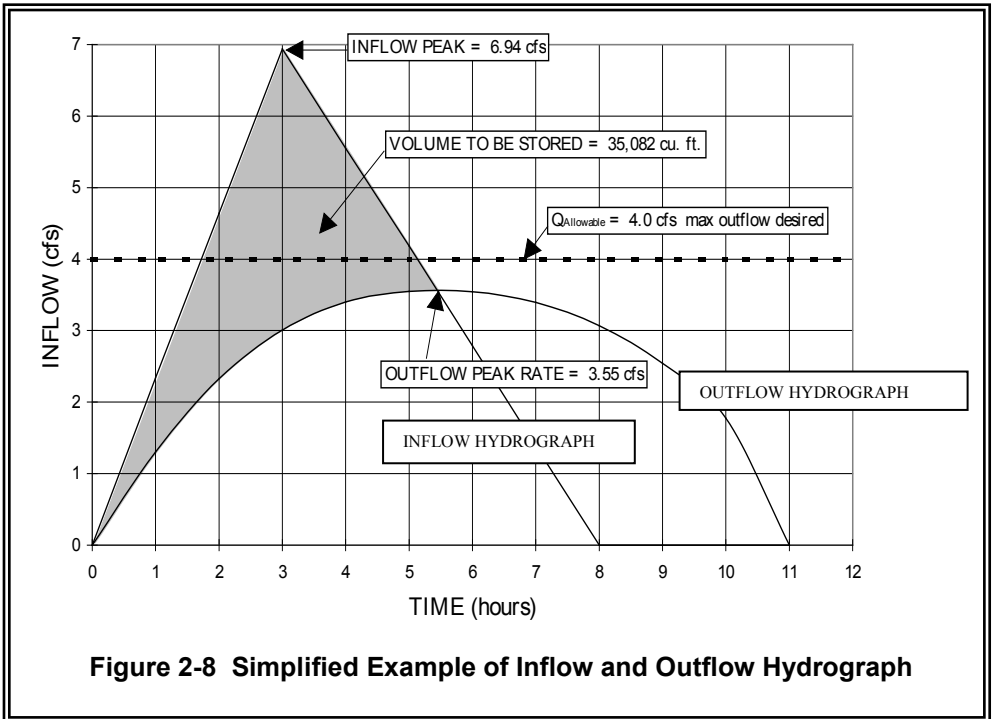
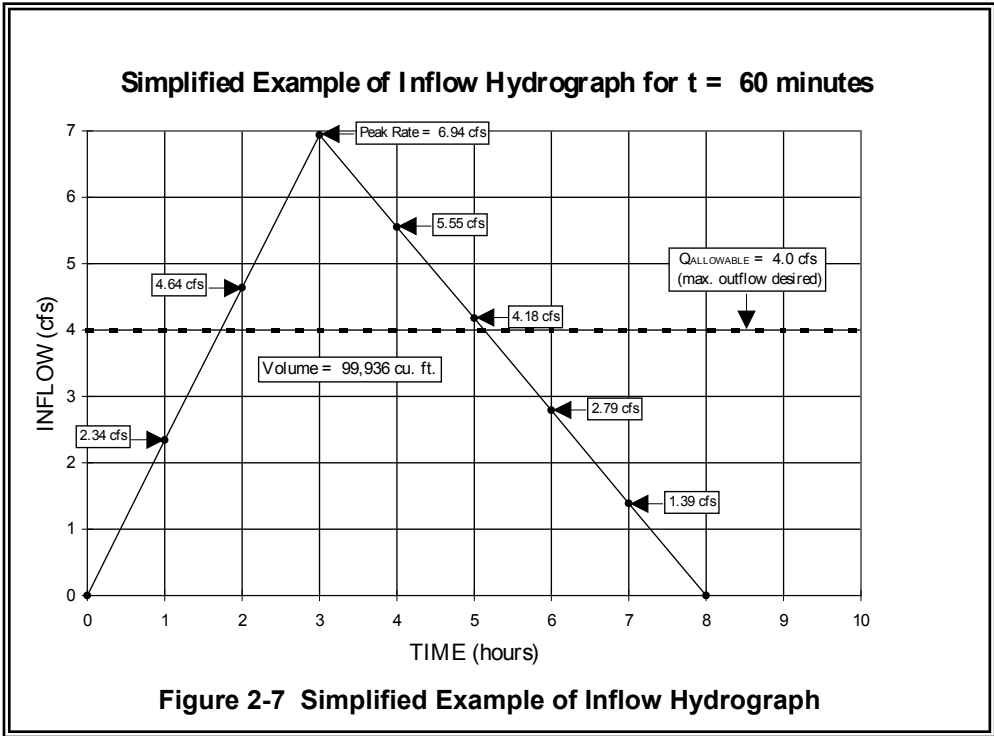


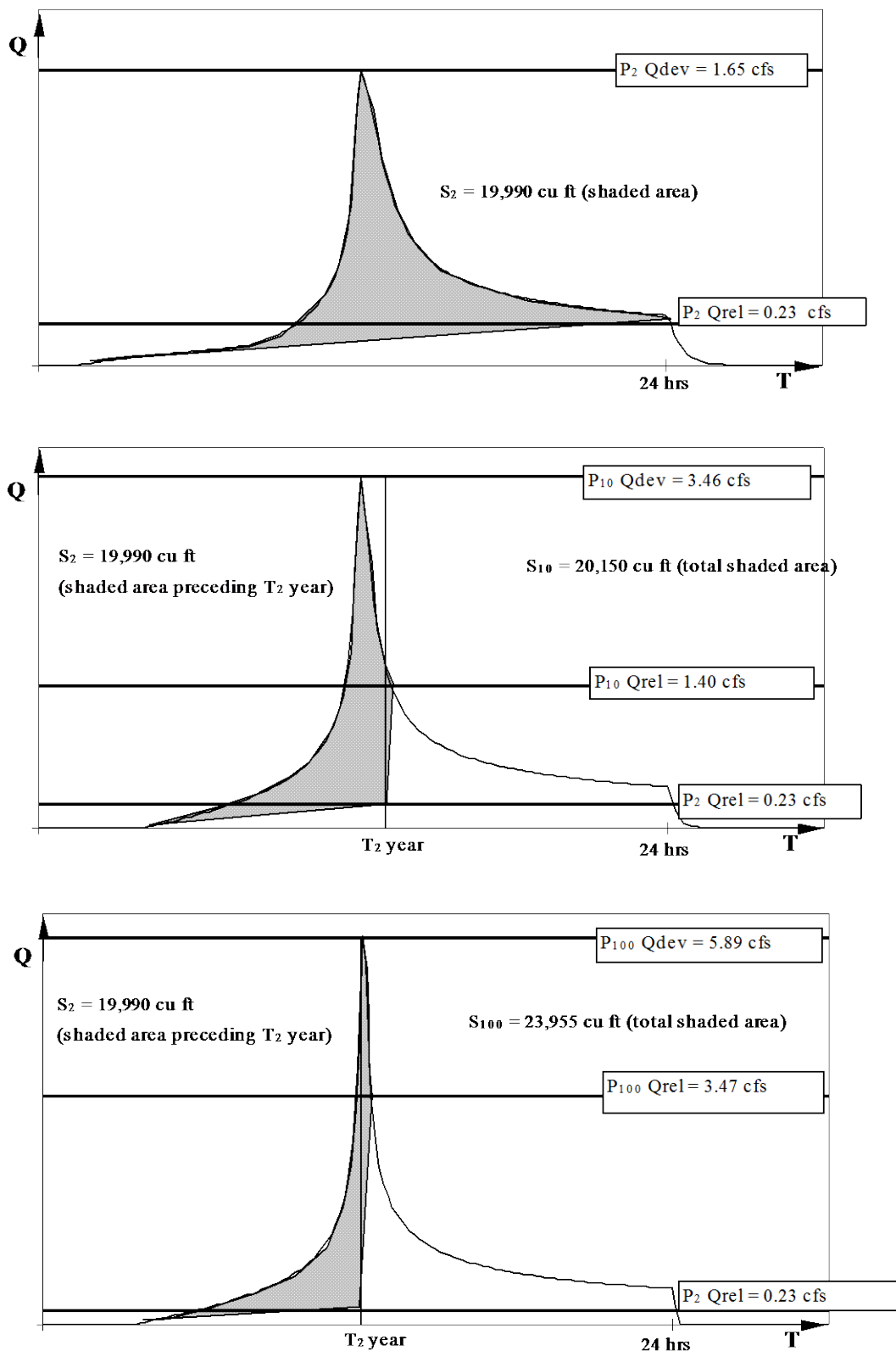
**Figure 2-2 24-Hour Design Storm Hyetographs  
Type IA Rainfall Distribution**



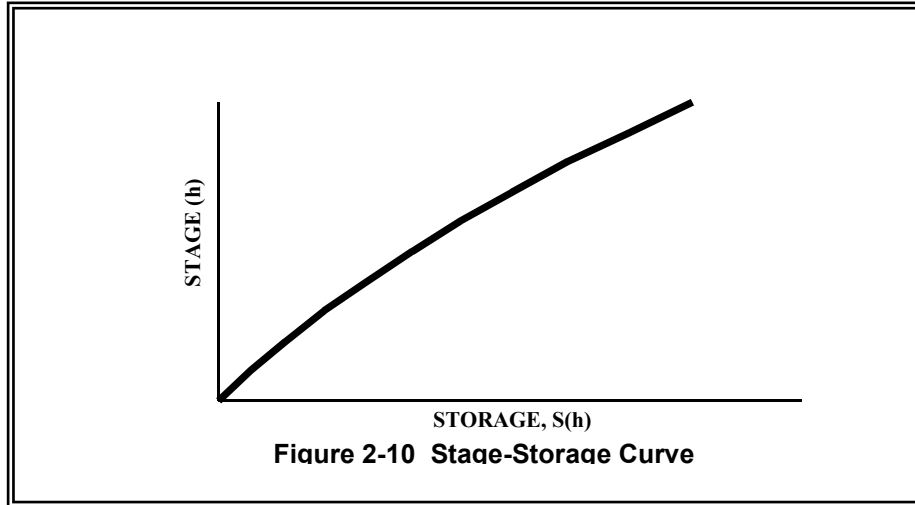




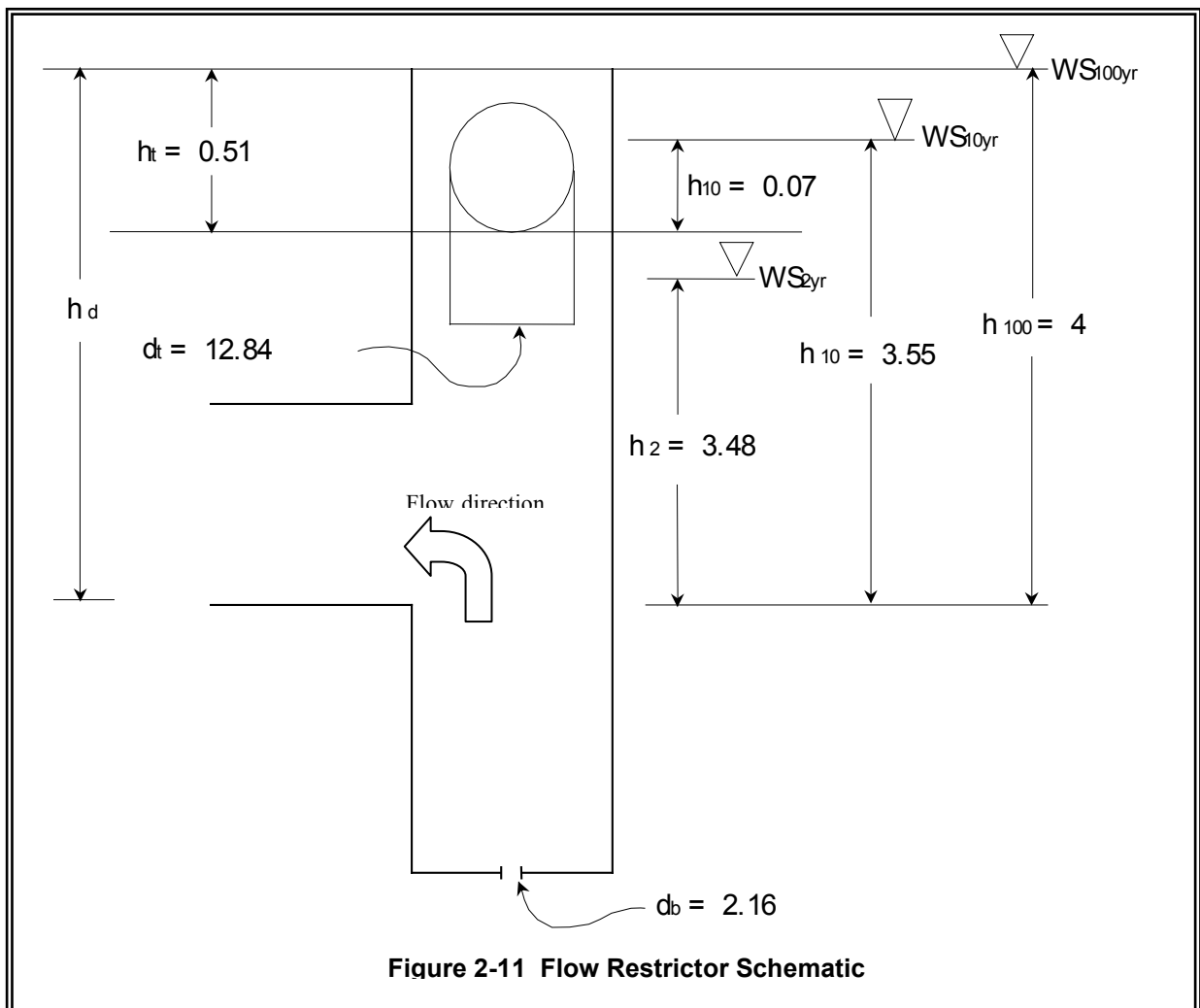


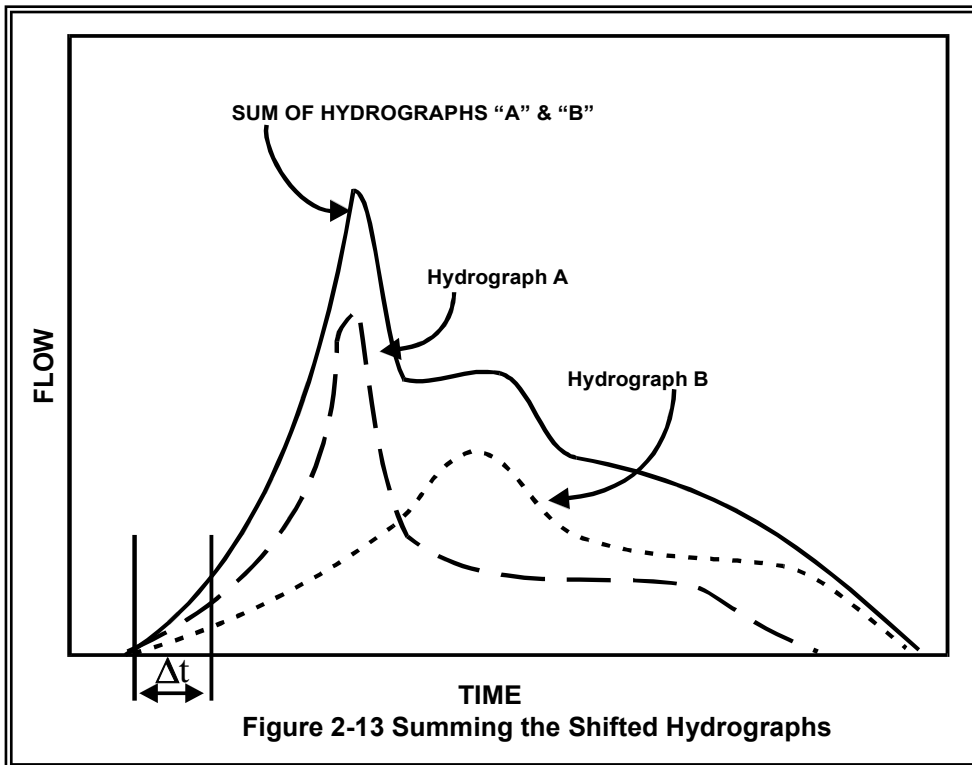
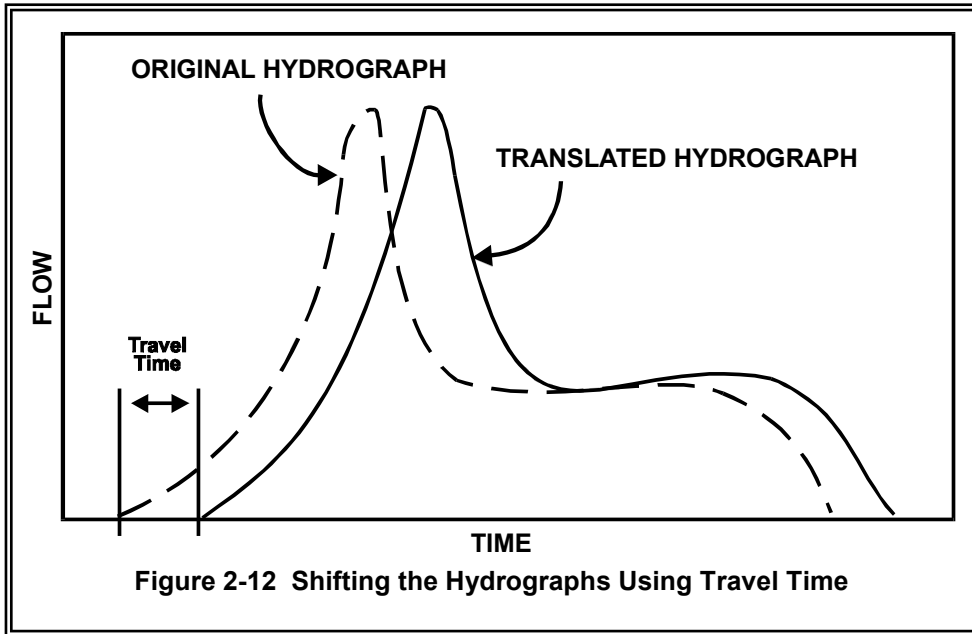


**Figure 2-9 Plots of the Developed Condition Inflow Hydrographs for the 2, 10, and 100-Year Design Storms**

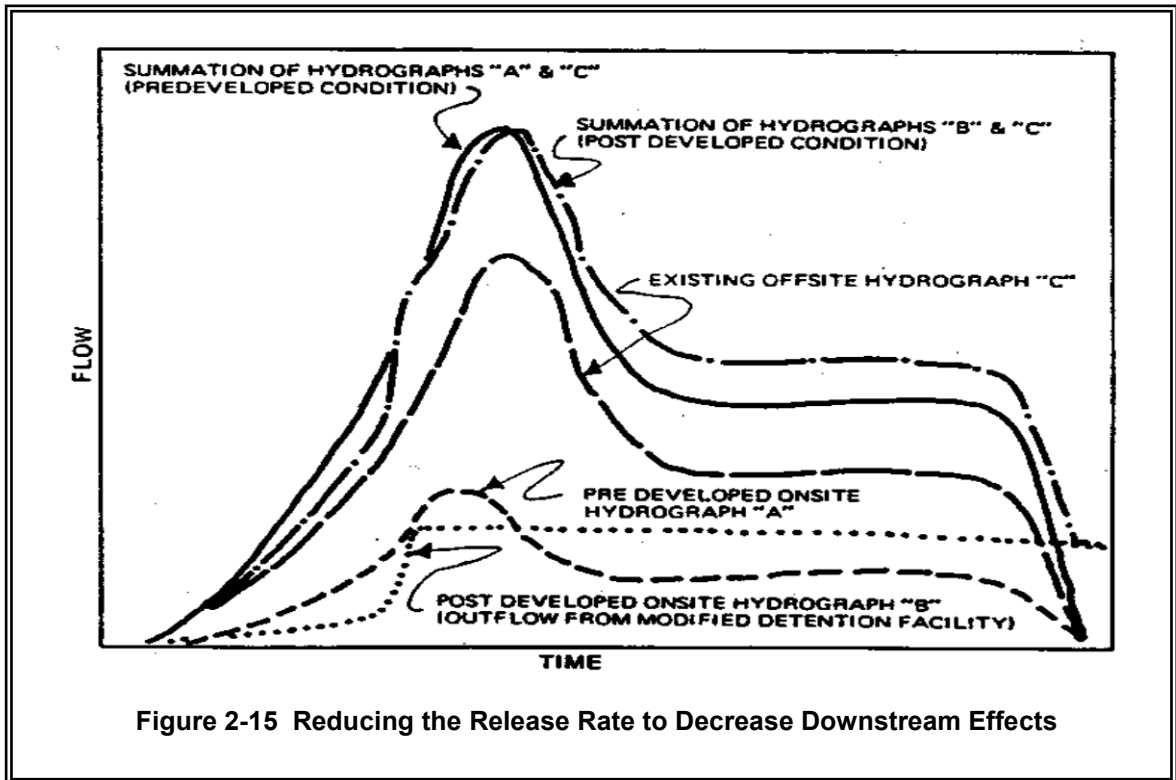
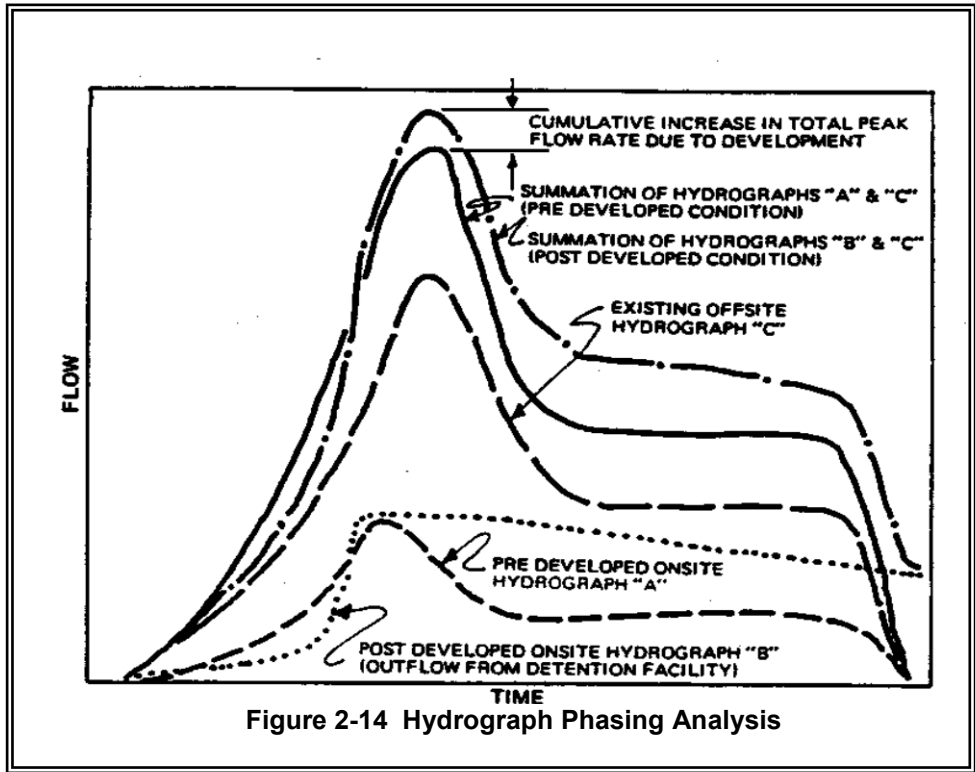


\*Note: Stage heights,  $h$ , should be adjusted so that they measure from the outlet invert rather than the pond bottom. In this example, the outlet invert is assumed to be at the same elevation as the pond bottom. Therefore, no adjustment is required.





Note:  $\Delta t$  has been previously defined as 10 minutes or less for a 24-hour duration storm and 60 minutes for a 7-day duration storm.



# Chapter 3 - Flow Control Design

---

*Note: Figures and text in Chapter 3 courtesy of King County and the Department of Ecology, except as noted.*

This chapter presents methods, criteria, and details for hydraulic analysis and design of flow control facilities and roof downspout controls. *Flow control facilities* are detention or infiltration facilities engineered to meet the flow control standards specified in Volume I. *Roof downspout controls* are infiltration or dispersion systems for use in individual lots, proposed plats, and short plats.

Roof downspouts may be used in conjunction with, and in addition to, any flow control facilities that may be necessary. Implementation of roof downspout controls may reduce the total effective impervious area and result in less runoff from these surfaces. Ecology's Hydrology Model incorporates flow credits for implementing roof downspout controls, in the Standard Residential menu only. Roof downspout controls include two scenarios:

- If roof runoff is ***infiltrated*** according to the requirements of this section, the roof area may be discounted from the total project area used for sizing the flow control facility as required in Volume I.
- If roof runoff is ***dispersed*** using a dispersion trench designed according to the requirements of this section on single-family lots greater than 22,000 square feet, and the *vegetative flow*\* path of the roof runoff is 50 feet or larger, the roof area may be modeled as grassed surface

This chapter also provides a description of the use of infiltration facilities for flow control. Additional design considerations pertaining to use of these facilities for runoff treatment are covered in Volume V.

Roof downspout controls and small site BMPs may be applied to individual commercial lot developments when the percent impervious area and pollutant characteristics are comparable to those from residential lots.

## 3.1 Roof Downspout Controls

This section presents the criteria for design and implementation of roof downspout controls. *Roof downspout controls* are simple pre-engineered designs for infiltrating and/or dispersing runoff from roof areas for the purposes of increasing opportunities for groundwater recharge and reduction of runoff volumes from new developments.

---

\* *Vegetative flow* path is measured from the downspout or dispersion system discharge point to the downstream property line, stream, wetland, or other impervious surface.

**Selection of Roof  
Downspout  
Controls**

Large lots in rural areas (5 acres or greater) typically have enough area to disperse or infiltrate roof runoff. **Lots created in urban areas will typically be smaller (about 8,000 square feet) and have a limited amount of area in which to site infiltration or dispersion trenches.** Downspout infiltration may be used in those soils that readily infiltrate (coarse sands and cobbles to medium sands). Dispersion BMPs may be used for urban lots located in less permeable soils, where if infiltration is not feasible. **Where dispersion is not feasible because of very small lot size, or where there is a potential for creating drainage problems on adjacent lots, downspouts shall be connected to the street storm drain system, which directs the runoff to a regional facility or major receiving water. Infiltration and dispersion systems shall have pre-approval by the City with regard to appropriateness for the project site.**

Where roof downspout controls are planned, the following three types should be considered in descending order of preference:

- Downspout infiltration systems – pre-approval required (Section 3.1.1)
- Downspout dispersion systems – pre-approval required (Section 3.1.2)
- Downspout perforated stub-out connections (Section 3.1.3)

Figure 3.1 illustrates, in general, how roof downspout controls are selected and applied in single-family subdivision projects. Where supported by appropriate soil infiltration tests, downspout infiltration in finer soils may be practical using a larger infiltration system.

Note: Other innovative downspout control BMPs such as rain barrels, ornamental ponds, downspout cisterns, or other downspout water storage devices may also be used if approved by the City.

**Roof Downspout  
Controls in  
Potential  
Landslide Hazard  
Areas**

If or where the City has identified “geologically hazardous areas” (WAC 365-195-410), lots immediately adjacent to the hazard area shall collect roof runoff in a tightline system which conveys the runoff to the City system or to the base of the slope and then into the City system. Easements across adjacent properties may be necessary to convey drainage to the City system.

**3.1.1 Downspout Infiltration Systems**

*Downspout infiltration systems* are trench designs for flow control and are intended only for use in infiltrating runoff from roof downspout drains. They are not designed to directly infiltrate runoff from pollutant-generating impervious surfaces. Volume V contains a discussion of infiltration trenches for runoff treatment (Ref. BMP 7.20).



## **Application**

The following apply to parcels as described in Volume I:

1. Single family subdivision projects subject to Minimum Requirement #7 for flow control (Volume I) may provide for individual downspout infiltration systems on all lots greater than 8000 square feet and smaller than 22,000 square feet, if feasible. The City may specify a different lot size that is more appropriate - based on local soil and slope conditions and rainfall. Concentrated flows may not be directed to adjoining lots. They must be dispersed and retained on the building lot to the maximum extent possible or discharged into the city system.
2. The feasibility or applicability of downspout infiltration must be evaluated for all subdivision single-family lots greater than 8000 square feet and smaller than 22,000 square feet. The evaluation procedure detailed below must be used to determine if downspout infiltration is feasible or whether downspout dispersion can be used in lieu of infiltration. Both options require City pre-approval.
3. For subdivision single-family lots greater than or equal to 22,000 square feet, downspout infiltration is optional, and the evaluation procedure detailed below may be used if downspout infiltration is being proposed voluntarily.
4. If site-specific tests indicate less than 3 feet of permeable soil from the proposed final grade to the seasonal high groundwater table, then a downspout dispersion system per Section 3.1.2 may be used in lieu of infiltration if dispersion criteria are met.
5. On lots or sites with more than 3 feet of permeable soil from the proposed final grade to the seasonal high groundwater table, downspout infiltration is considered feasible if the soils are outwash type soils and the infiltration trench can be designed to meet the minimum design criteria specified below.

*Note: If downspout infiltration is not provided on these lots, then a downspout dispersion system must be evaluated per Section 3.1.2 and provided where appropriate, with City pre-approval.*

## **Flow Credit for Roof Downspout Infiltration**

If roof runoff is infiltrated according to the requirements of this section, the roof area may be discounted from the project area used for sizing the flow control facility as required in Volume I, Minimum Requirement #7.

## **Procedure for Evaluating Feasibility**

1. A soils report shall be prepared by a locally licensed onsite sewage designer or by other suitably trained persons working under the supervision of a professional engineer registered in the State of Washington to determine if soils suitable for infiltration are present on the site. The report must reference a sufficient number of soils logs to establish the type and limits of soils on the project site. The report should at a minimum identify the limits of any *outwash type soils* (i.e., those meeting USDA soil texture classes ranging from coarse sand and cobbles to medium sand) versus other soil types and include an inventory of topsoil depth. Please reference *Section 3.2.4 - Site*

*Characterization Criteria*, for the specific information and analysis required as part of a soils report.

*Note: On lots or sites with no outwash type soils, a downspout dispersion system per Section 3.1.2 may be feasible in lieu of infiltration.*

2. On lots or sites containing outwash type soils (coarse sand and cobbles to medium sand), additional site-specific testing must be done. Individual lot or site tests must consist of at least one soils log at the location of the infiltration system, a minimum of 4 feet in depth (from proposed grade), identifying the SCS series of the soil and the USDA textural class of the soil horizon through the depth of the log, and noting any evidence of high groundwater level, such as mottling.

*Note: This testing must also be carried out on lots or sites where downspout infiltration is being proposed in soils other than outwash.*

3. If site-specific tests indicate less than 3 feet of permeable soil from the proposed final grade to the seasonal high groundwater table, then a downspout dispersion system per Section 3.1.2 may be feasible in lieu of infiltration.
4. On lots or sites with more than 3 feet of permeable soil from the proposed final grade to the seasonal high groundwater table, downspout infiltration is considered feasible if the soils are outwash type soils and the infiltration trench can be designed to meet the minimum design criteria specified below. City pre-approval is required.

**Design Criteria  
for Infiltration  
Trenches**

Figure 3-1 shows a typical downspout infiltration trench system, and Figure 3-2 presents an alternative infiltration trench system for sites with coarse sand and cobble soils. These systems are designed as specified below.

**General**

1. The following minimum lengths (linear feet) per 1,000 square feet of roof area based on soil type may be used for sizing downspout infiltration trenches.

Coarse sands and cobbles	20 LF
Medium sand	30 LF
Fine sand, loamy sand	75 LF
Sandy loam	125 LF
Loam	190 LF

2. Maximum length of trench must not exceed 100 feet from the inlet sump.
3. Minimum spacing between trenches shall be 4 feet measured from the edge of trench.
4. Filter fabric must be placed over the drain rock as shown on Figure 3-1 prior to backfilling.
5. Infiltration trenches may be placed in fill material if the fill is placed and compacted under the direct supervision of a geotechnical engineer or

professional civil engineer with geotechnical expertise, and if the measured infiltration rate is at least 8 inches per hour. Trench length in fill must be 60 linear feet per 1,000 square feet of roof area. Infiltration rates can be tested using the methods described in Section 3.3.

6. Infiltration trenches should not be built on slopes steeper than 25 percent (4:1). A geotechnical analysis and report shall be required on slopes over 15 percent or if located within 200 feet of the top of steep slope or landslide hazard area. More stringent setbacks may be required as part of the Tacoma Municipal Code.
7. Trenches may be located under pavement if a small yard drain or catch basin with grate cover is placed at the end of the trench pipe such that overflow would occur out of the catch basin at an elevation at least one foot below that of the pavement, and in a location which can accommodate the overflow without creating a significant adverse impact to downhill properties or drainage systems. This is intended to prevent saturation of the pavement in the event of system failure.

### **Setbacks**

The City requires specific setbacks for sites with steep slopes, landslide areas, open water features, springs, wells, and septic tank drain fields. Adequate room for maintenance access and equipment shall also be considered. Project proponents should consult the Tacoma Municipal Codes to determine all applicable setback requirements. Where a conflict between setbacks occurs, the City shall require compliance with the most stringent of the setback requirements from the various codes/regulations. Required setbacks are as follows or as determined by a qualified geotechnical engineer:

1. Minimum spacing between trenches shall be 4 feet measured from the edge of trench.
2. Stormwater infiltration facilities shall be set back at least 100 feet from drinking water wells, septic tanks or drainfields, and springs used for public drinking water supplies. Infiltration facilities upgradient of drinking water supplies and within 1, 5, and 10-year time of travel zones must comply with Health Dept. requirements (Washington Wellhead Protection Program, DOH, 12/93).
3. All infiltration systems shall be at least 10 feet from any structure. If necessary, setbacks shall be increased from the minimum 10 feet in order to maintain a 1:1 side slope for future excavation and maintenance
4. All infiltration systems shall be placed at least 5 feet from any property line. If necessary, setbacks shall be increased from the minimum 5 feet in order to maintain a 1:1 side slope for future excavation and maintenance.
5. Infiltration systems shall be setback from sensitive areas, steep slopes, landslide hazard areas, and erosion hazard areas as governed by the Tacoma Municipal Code. Runoff discharged near landslide hazard areas must be evaluated by a geotechnical engineer or qualified geologist. The discharge point shall not be placed on or

above slopes greater than 20% or above erosion hazard areas without evaluation by a geotechnical engineer or qualified geologist and City approval.

6. For sites with septic systems, infiltration systems shall be downgradient of the drainfield unless the site topography clearly prohibits subsurface flows from intersecting the drainfield.

### 3.1.2 Downspout Dispersion Systems

*Downspout dispersion systems* are splash blocks or gravel-filled trenches, which serve to spread roof runoff over vegetated pervious areas. Dispersion attenuates peak flows by slowing entry of the runoff into the conveyance system, allows for some infiltration, and provides some water quality benefits. Also refer to BMP T5.10, Downspout Diversion, in Volume V.

#### **Application**

Downspout dispersion may be used in all subdivision single-family lots, which meet one of the following criteria (with City pre-approval):

1. Lots greater than or equal to 22,000 square feet where downspout infiltration is not being provided according to the requirements in Section 3.1.1.
2. Lots smaller than 22,000 square feet where soils are not suitable for downspout infiltration (as determined in Section 3.1.1) and where the design criteria below can be met.

#### **Flow Credit for Roof Downspout Dispersion**

If roof runoff is dispersed using a dispersion trench designed according to the requirements of this section on single-family lots greater than 22,000 square feet, and the *vegetative flow*\* path of the roof runoff is 50 feet or larger, the roof area may be modeled as grassed surface - rather than impervious surface - when sizing the flow control facility as required in Volume I, Minimum Requirement #7.

#### **Design Criteria**

1. Downspout trenches designed as shown in Figure 3-3 should be used for all downspout dispersion applications except where splash blocks are allowed below.
2. Splash blocks shown in Figure 3-5 may be used for downspouts discharging to a *vegetated flowpath* at least 50 feet in length as measured from the downspout to the downstream property line, structure, steep slope, stream, wetland, or other impervious surface. Sensitive area buffers may count toward flowpath lengths.
3. If the vegetated flowpath (measured as defined above) is less than 25 feet on a subdivision single-family lot, a perforated stub-out connection per Section 3.1.3 may be used in lieu of downspout dispersion. A perforated stub-out may also be used where implementation of downspout dispersion might cause erosion or flooding problems, either on site or on adjacent lots. This provision might be appropriate, for example, for lots constructed on steep hills where downspout discharge could be cumulative and might pose a potential hazard for lower lying

---

\* *Vegetative flow* path is measured from the downspout or dispersion system discharge point to the downstream property line, stream, wetland, or other impervious surface.

lots, or where dispersed flows could create problems for adjacent offsite lots. Perforated stub-outs are not appropriate when seasonal water table is <1 foot below trench bottom.

4. For sites with septic systems, the discharge point of all dispersion systems must be downgradient of the drainfield. This requirement may be waived if site topography clearly prohibits flows from intersecting the drainfield.

#### **Design Criteria for Dispersion Trenches**

1. No erosion or flooding of downstream properties shall result.
2. A vegetated flowpath of at least 25 feet in length must be maintained between the outlet of the trench and any property line, structure, stream, wetland, or impervious surface. A vegetated flowpath of at least 50 feet in length must be maintained between the outlet of the trench and any steep slope. Sensitive area buffers may count towards flowpath lengths.
3. Trenches serving up to 700 square feet of roof area may be simple 10-foot-long by 2-foot wide gravel filled trenches as shown in Figure 3-3. For roof areas larger than 700 square feet, a dispersion trench with notched grade board as shown in Figure 3-4 may be used as approved by the City. The total length of this design must not exceed 50 feet and must provide at least 10 feet of trench per 700 square feet of roof area.
4. All dispersion systems shall be at least 10 feet from any structure. If necessary, setbacks shall be increased from the minimum 10 feet in order to maintain a 1:1 side slope for future excavation and maintenance.
5. All dispersion systems shall be placed at least 5 feet from any property line. If necessary, setbacks shall be increased from the minimum 5 feet in order to maintain a 1:1 side slope for future excavation and maintenance.
6. Dispersion systems shall be setback from sensitive areas, steep slopes, landslide hazard areas, and erosion hazard areas as governed by the Tacoma Municipal Code.
7. Runoff discharged towards landslide hazard areas must be evaluated by a geotechnical engineer or qualified geologist. The discharge point shall not be placed on or above slopes greater than 20% or above erosion hazard areas without evaluation by a geotechnical engineer or qualified geologist and City approval.

#### **Design Criteria for Splashblocks**

A typical downspout splashblock is shown in Figure 3-5. In general, if the ground is sloped away from the foundation and there is adequate vegetation and area for effective dispersion, splashblocks will adequately disperse storm runoff. If the ground is fairly level, if the structure includes a basement, or if foundation drains are proposed, splashblocks with downspout extensions may be a better choice because the discharge point is moved away from the foundation. Downspout extensions can include piping to a splashblock/discharge point a considerable distance

from the downspout, as long as the runoff can travel through a well-vegetated area as described below.

The following apply to the use of splashblocks:

1. A vegetated flowpath of at least 50 feet should be maintained between the discharge point and any property line, structure, steep slope, stream, wetland, lake, or other impervious surface. Sensitive area buffers may count toward flowpath lengths.
2. Flows shall not be directed onto sidewalks.
3. A maximum of 700 square feet of roof area may drain to each splashblock.
4. A splashblock or a pad of crushed rock (2 feet wide by 3 feet long by 6 inches deep) should be placed at each downspout discharge point.
5. No erosion or flooding of downstream properties may result.
6. Runoff discharged towards landslide hazard areas must be evaluated by a professional engineer with geotechnical expertise or a qualified geologist. Splash blocks may not be placed on or above slopes greater than 20% or above erosion hazard areas without evaluation by a professional engineer with geotechnical expertise or qualified geologist and City approval.
7. For sites with septic systems, the discharge point must be downslope of the primary and reserve drainfield areas. This requirement may be waived if site topography clearly prohibits flows from intersecting the drainfield or where site conditions (soil permeability, distance between systems, etc) indicate that this is unnecessary.

### **3.1.3 Perforated Stub-Out Connections**

*A perforated stub-out connection* is a length of perforated pipe within a gravel-filled trench that is placed between roof downspouts and a stub-out to the private or City drainage system. Figure 3-6 illustrates a perforated stub-out connection. These systems are intended to provide some infiltration during drier months. During the wet winter months, they may provide little or no flow control. Perforated stub-outs are not appropriate when seasonal water table is < 1 foot below trench bottom.

In single-family subdivision projects subject to Minimum Requirement #7 for flow control (see Volume I), perforated stub-out connections may be used only when downspout infiltration or dispersion is not feasible per the criteria in Sections 3.1.1 and 3.1.2.

Location of the connection should be selected to allow a maximum amount of runoff to infiltrate into the ground (ideally a dry location on the site that is relatively well drained). To facilitate maintenance, the perforated pipe portion of the system should not be located under impervious or heavily compacted (e.g., driveways and parking areas) surfaces.

Perforated stub-out connections should consist of at least 10 feet of perforated pipe per 5,000 square feet of roof area laid in a level, 2-foot wide trench backfilled with washed drain rock. The drain rock should extend to a depth of at least 8 inches below the bottom of the pipe and should cover the pipe. The pipe should be laid level and the rock trench covered with filter fabric and 6 inches of fill (see Figure 3-6).

A perforated pipe stub-out connection shall not be placed within 10 feet of any structure. This will require a minimum length of 10-feet of solid pipe prior to installing the perforated pipe. Construction of perforated pipe stub-outs in close proximity to a structure could result in damage to the foundation and structure due to settling. The remaining setbacks are the same as for infiltration trenches.

Potential runoff discharge towards a landslide hazard area must be evaluated by a professional engineer with geotechnical expertise or a qualified geologist. The perforated portion of the pipe may not be placed on or above slopes greater than 20% or above erosion hazard areas without evaluation by a professional engineer with geotechnical expertise or qualified geologist and City approval.

For sites with septic systems, the perforated portion of the pipe must be downgradient of the drainfield primary and reserve areas. This requirement can be waived if site topography will clearly prohibit flows from intersecting the drainfield or where site conditions (soil permeability, distance between systems, etc) indicate that this is unnecessary.

## **3.2 Infiltration Stormwater Quantity and Flow Control**

### **3.2.1 Purpose**

To provide infiltration capacity for stormwater runoff quantity and flow control. *Note: Specifications for runoff treatment infiltration BMPs are discussed in Section 7.3, Volume V.*

### **3.2.2 Description**

An infiltration BMP is typically an open basin (pond), trench, or buried perforated pipe used for distributing the stormwater runoff into the underlying soil (See Figure 3-7).

Coarser more permeable soils can be used for quantity control provided that the stormwater discharge does not cause a violation of ground water quality criteria. Typically, treatment for removal of TSS, oil, and/or soluble pollutants is necessary prior to conveyance to an infiltration BMP. The hydraulic design goal should be to mimic the natural hydrologic balance between surface and ground water, as needed to protect water uses.

### **3.2.3 Applications**

Where appropriate, infiltration facilities are used to convey stormwater runoff from new development or redevelopment to the ground and ground water after appropriate treatment. Runoff, in excess of the infiltration

capacity, must be detained and released in compliance with the flow control requirement in Volume I. Where appropriate, infiltration may also be used for the following:

- Ground water recharge
- Retrofits in limited land areas: Infiltration trenches can be considered for residential lots, commercial areas, parking lots, and open space areas.
- Flood control
- Streambank erosion control

### **3.2.4 Site Characterization Criteria**

One of the first steps in siting and designing infiltration facilities is to conduct a characterization study that includes the following:

*Note: Information gathered during initial geotechnical investigations can be used for the site characterization.*

#### **Surface Features Characterization:**

- Topography within 500 feet of the proposed facility.
- Anticipated site use (street/highway, residential, commercial, high-use site).
- Location of water supply wells within 500 feet of proposed facility.
- Location of ground water protection areas and/or 1, 5 and 10 year time of travel zones for municipal well protection areas.
- A description of local site geology, including soil or rock units likely to be encountered, the groundwater regime, and geologic history of the site.

#### **Subsurface Characterization:**

- Subsurface explorations (test holes or test pits) to a depth below the base of the infiltration facility of at least 5 times the maximum depth of ponded water proposed for the infiltration facility design
- Test holes or test pit explorations shall be conducted during the wet groundwater season (December 1<sup>st</sup> through April 30<sup>th</sup>) to provide accurate groundwater saturation and groundwater information.
- Continuous sampling (representative samples from each soil type and/or unit within the infiltration receptor) to a depth below the base of the infiltration facility of 2.5 times the maximum design ponded water depth, but not less than 6 feet.
  - For basins, at least one test pit or test hole per 5,000 ft<sup>2</sup> of basin infiltrating surface (in no case less than two per basin).
  - For trenches, at least one test pit or test hole per 50 feet of trench length (in no case less than two per trench).

*Note: The depth and number of test holes or test pits, and samples should be increased, if in the judgment of a licensed*



*engineer with geotechnical expertise (P.E.), or other licensed professional acceptable to the City, the conditions are highly variable and such increases are necessary to accurately estimate the performance of the infiltration system. The exploration program may also be decreased if, in the opinion of the licensed engineer or other professional, the conditions are relatively uniform and the borings/test pits omitted will not influence the design or successful operation of the facility. In high water table sites, the subsurface exploration sampling need not be conducted lower than two (2) feet below the ground water table.*

- Prepare detailed logs for each test pit or test hole and a map showing the location of the test pits or test holes. Logs must include at a minimum, depth of pit or hole, soil descriptions, depth to water, presence of stratification (*Note: Logs must substantiate whether stratification does or does not exist. The licensed professional may consider additional methods of analysis to substantiate the presence of stratification that will significantly impact the design of the infiltration facility*).

#### **Infiltration Rate Determination:**

Determine the representative infiltration rate of the unsaturated vadose zone based on infiltration tests and/or grain-size distribution/texture (see next section). Determine site infiltration rates using the Pilot Infiltration Test (PIT) described in Appendix V-B, if practicable. Such site testing should be considered to verify infiltration rate estimates based on soil size distribution and textural analysis. Infiltration rates may also be estimated based on soil grain-size distributions from test pits or test hole samples (particularly where a sufficient source of water does not exist to conduct a pilot infiltration test). As a minimum, one soil grain-size analysis per soil stratum in each test hole shall be performed within 2.5 times the maximum design water depth, but not less than 6 feet.

#### **Soil Testing:**

At a minimum, soil characterization for each soil unit (soils of the same texture, color, density, compaction, consolidation and permeability) encountered shall include:

- Grain-size distribution (ASTM D422 or equivalent AASHTO specification)
- Textural class (USDA) (See Table 3.1 and Figure 3-8)
- Percent clay content (include type of clay, if known)
- Color/mottling
- Variations and nature of stratification

#### **Infiltration Receptor:**

Infiltration receptor (unsaturated and saturated soil receiving the stormwater) characterization should include:

- Installation of ground water monitoring wells (at least three per infiltration facility, or three hydraulically connected surface and ground water features that will establish a three-dimensional relationship for the ground water table, unless the highest ground water level is known to be at least 50 feet below the proposed infiltration facility) to:
  - monitor the seasonal ground water levels at the site during at least one wet season, and,
  - consider the potential for both unconfined and confined aquifers, or confining units, at the site that may influence the proposed infiltration facility as well as the groundwater gradient. Other approaches to determine ground water levels at the proposed site could be considered if pre-approved by the local government jurisdiction, and,
  - determine the ambient ground water quality, if that is a concern.
- An estimate of the volumetric water holding capacity of the infiltration receptor soil. This is the soil layer below the infiltration facility and above the seasonal high-water mark, bedrock, hardpan, or other low permeability layer. This analysis should be conducted at a conservatively high infiltration rate based on vadose zone porosity, and the water quality runoff volume to be infiltrated. This, along with an analysis of ground water movement, will be useful in determining if there are volumetric limitations that would adversely affect drawdown.
- Depth to ground water table and to bedrock/impermeable layers
- Seasonal variation of ground water table based on well water levels and observed mottling
- Existing ground water flow direction and gradient
- Lateral extent of infiltration receptor
- Horizontal hydraulic conductivity of the saturated zone to assess the aquifer's ability to laterally transport the infiltrated water.

Impact of the infiltration rate and volume at the project site on ground water mounding, flow direction, and water table; and the discharge point or area of the infiltrating water. A ground water mounding analysis should be conducted at all sites where the depth to seasonal ground water table or low permeability stratum is less than 15 feet and the runoff to the infiltration facility is from more than one acre. *(The site professional can consider conducting an aquifer test, or slug test and the type of ground water mounding analysis necessary at the site.)*

Note: A detailed soils and hydrogeologic investigation should be conducted if potential pollutant impacts to ground water are a concern, or if the applicant is proposing to infiltrate in areas underlain by till or other impermeable layers. (Suggested references: "Implementation Guidance for the Ground Water Quality Standards", Department of Ecology, publication 96-2, 1996, and, "Washington State Water Quality Guide," Natural Resources Conservation Service, W. 316 Boone Ave, Spokane WA 99201-2348).

### 3.2.5 Design Infiltration Rate Determination - Guidelines and Criteria

The representative site infiltration rate must be determined from soil test results, the stratification identified during the site characterization, and/or in-situ field measurements.

Historically, infiltration rates have been estimated from soil grain size distribution (gradation) data using the United States Department of Agriculture (USDA) textural analysis approach. To use the USDA textural analysis approach, the grain size distribution test must be conducted in accordance with the USDA test procedure (SOIL SURVEY MANUAL, U.S. Department of Agriculture, October 1993, page 136). This manual only considers soil passing the #10 sieve (2 mm) (U.S. Standard) to determine percentages of sand, silt, and clay for use in Figure 3-8 (USDA Textural Triangle). However, many soil test laboratories use the ASTM soil size distribution test procedure (ASTM D422), which considers the full range of soil particle sizes, to develop soil size distribution curves. ***The ASTM soil gradation procedure must not be used with Figure 3-8 to perform USDA soil textural analyses.***

#### ***Three Methods for Determining Long-term Infiltration Rates for Sizing Infiltration Facilities***

For designing the infiltration facility the site professional should select one of the three methods described below that will best represent the long-term infiltration rate at the site. The long-term infiltration rate should be used for routing and sizing the basin/trench for the maximum drawdown time of 24 hours. If the pilot infiltration test (Table 3.3) or hindcast approach (Table 3.2) is selected corroboration with a textural based infiltration rate (Table 3.1) is also desirable. Appropriate correction factors must be applied as specified. Verification testing of the completed facility is strongly encouraged. (See Site Suitability Criterion # 7-Verification Testing)

#### ***Method 1 - USDA Soil Textural Classification***

Table 3.1 provides the correlation between USDA soil texture and infiltration rates for estimating infiltration rates for homogeneous soils based on gradations from soil samples and textural analysis. The USDA soil texture – infiltration rate correlation in Table 3.1 is based on the correlation developed by Rawls, et. al. (1982), but with minor changes in the infiltration rates based on WEF/ASCE (1998). The infiltration rates provided through this correlation represent short-term conservative rates for homogeneous soils. These rates do not consider the effects of site variability and long-term clogging due to siltation and biomass buildup in the infiltration facility.

Based on experience with long-term full-scale infiltration pond performance, Ecology's Technical Advisory Committee (TAC) recommends that the short-term infiltration rates be reduced as shown in Table 3.1, dividing by a correction factor of 2 to 4, depending on the soil textural classification. The correction factors provided in Table 3.1 represent an average degree of long-term facility maintenance, TSS

reduction through pretreatment, and site variability in the subsurface conditions. These conditions might include deposits of ancient landslide debris, buried stream channels, lateral grain size variability, and other factors that affect homogeneity).

These correction factors could be reduced, subject to the approval of the City, under the following conditions:

- For sites with little soil variability,
- Where there will be a high degree of long-term facility maintenance,
- Where specific, reliable pretreatment is employed to reduce TSS entering the infiltration facility

**In no case shall a correction factor less than 2.0 be used.**

Correction factors higher than those provided in Table 3.1 shall be considered for situations where long-term maintenance will be difficult to implement, where little or no pretreatment is anticipated, or where site conditions are highly variable or uncertain. These situations require the use of best professional judgment by the site engineer and the approval of the City. An Operation and Maintenance plan and a financial bonding plan may be required by the City.

#### Method 2 - ASTM Gradation Testing at Full Scale Infiltration Facilities

As an alternative to Table 3.1, recent studies by Massmann and Butchart (2000) were used to develop the correlation provided in Table 3.2. These studies compare infiltration measurements from full-scale infiltration facilities to soil gradation data developed using the ASTM procedure (ASTM D422). The primary source of the data used by Massmann and Butchart was from Wiltsie (1998), who included limited infiltration studies only on Thurston County sites. However, Massmann and Butchart also included limited data from King and Clark County sites in their analysis. This table provides recommended long-term infiltration rates that have been correlated to soil gradation parameters using the ASTM soil gradation procedure.

Table 3.2 can be used to estimate long-term design infiltration rates directly from soil gradation data, subject to the approval of the local jurisdiction. As is true of Table 3.1, the long-term rates provided in Table 3.2 represent average conditions regarding site variability, the degree of long-term maintenance and pretreatment for TSS control. The long-term infiltration rates in Table 3.2 may need to be decreased if the site is highly variable, or if maintenance and influent characteristics are not well controlled. The data that forms the basis for Table 3.2 was from soils that would be classified as sands or sandy gravels. No data was available for finer soils. Therefore, Table 3.2 should not be used for soils with a  $d_{10}$  size (10% passing the size listed) less than 0.05 mm (U.S. Standard Sieve).

The infiltration rates provided in Tables 3.1 and 3.2 represent rates for homogeneous soil conditions. If more than one soil unit is encountered within 6 feet of the base of the facility or 2.5 times the proposed maximum

water design depth, use the lowest infiltration rate determined from each of the soil units as the representative site infiltration rate.

If soil mottling, fine silt or clay layers, which cannot be fully represented in the soil gradation tests, are present below the bottom of the infiltration pond, the infiltration rates provided in the tables will be too high and should be reduced. Based on limited full-scale infiltration data (Massmann and Butchart, 2000; Wiltsie, 1998), it appears that the presence of mottling indicates soil conditions that reduce the infiltration rate for homogeneous conditions by a factor of 3 to 4.

### Method 3 - In-situ Infiltration Measurements

Where feasible, Ecology encourages in-situ infiltration measurements, using a procedure such as the Pilot Infiltration Test (PIT) described in Appendix V-B. Small-scale infiltration tests such as the EPA Falling Head or double ring infiltrometer test (ASTM D3385-88) are not permitted unless modified versions are determined to be acceptable by Ecology or the City at a later date. These small-scale infiltration tests tend to seriously overestimate infiltration rates and, based on recent TAC experience, are considered unreliable.

As in the previous methods, the infiltration rate obtained from the test shall be considered to be a short-term rate. This short-term rate must be reduced through correction factors to account for site variability and number of tests conducted, degree of long-term maintenance and influent pretreatment/control, and potential for long-term clogging due to siltation and bio-buildup.

The typical range of correction factors to account for these issues, based on TAC experience, is summarized in Table 3.3. The range of correction factors is for general guidance only. The specific correction factors used shall be determined based on the professional judgment of the licensed engineer or other site professional considering all issues which may affect the long-term infiltration rate, subject to the approval of the City. The following discussions are to provide assistance in determining the partial correction factors to apply in Table 3.3.

**Site variability and number of locations tested** - The number of locations tested must be capable of producing a picture of the subsurface conditions that fully represents the conditions throughout the facility site. The partial correction factor used for this issue depends on the level of uncertainty that adverse subsurface conditions may occur. If the range of uncertainty is low - for example, conditions are known to be uniform through previous exploration and site geological factors - one pilot infiltration test may be adequate to justify a partial correction factor at the low end of the range. If the level of uncertainty is high, a partial correction factor near the high end of the range may be appropriate. This might be the case where the site conditions are highly variable due to a deposit of ancient landslide debris, or buried stream channels. In these cases, even with many explorations and several pilot infiltration tests, the level of uncertainty may still be high. A partial correction factor near the high end of the range could be assigned where conditions have a more typical

variability, but few explorations and only one pilot infiltration test is conducted. That is, the number of explorations and tests conducted do not match the degree of site variability anticipated.

**Degree of long-term maintenance to prevent siltation and bio-buildup -**

The standard of comparison here is the long-term maintenance requirements provided in Volume V, Chapter 4, and any additional requirements by the City. Full compliance with these requirements would be justification to use a partial correction factor at the low end of the range. If there is a high degree of uncertainty that long-term maintenance will be carried out consistently, or if the maintenance plan is poorly defined, a partial correction factor near the high end of the range may be justified.

**Degree of influent control to prevent siltation and bio-buildup -** A partial correction factor near the high end of the range may be justified under the following circumstances:

1. If the infiltration facility is located in a shady area where moss buildup or litter fall buildup from the surrounding vegetation is likely and cannot be easily controlled through long-term maintenance
2. If there is minimal pre-treatment, and the influent is likely to contain moderately high TSS levels.

If influent into the facility can be well controlled such that the planned long-term maintenance can easily control siltation and biomass buildup, then a partial correction factor near the low end of the range may be justified.

The determination of long-term design infiltration rates from in-situ infiltration test data involves a considerable amount of engineering judgment. Therefore, when reviewing or determining the final long-term design infiltration rate, the City may consider the results of both textural analyses and in-situ infiltration tests results when available.

**3.2.6 Site Suitability Criteria (SSC)**

This section provides criteria that must be considered for siting infiltration systems for flow control. *Note: Criteria for runoff treatment design are included in Volume V.* When a site investigation reveals that any of the seven applicable criteria cannot be met, appropriate mitigation measures must be implemented so that the infiltration facility will not pose a threat to safety, health, and the environment.

For site selection and design decisions a geotechnical and hydrogeologic report should be prepared by a qualified engineer with geotechnical and hydrogeologic experience, or an equivalent professional acceptable to the City, under the seal of a registered Professional Engineer. The design engineer may utilize a team of certified or registered professionals in soil science, hydrogeology, geology, and other related fields.

### **SSC-1 Setback Criteria**

Setback requirements are generally required by the City, uniform building code requirements, or other state regulations. Where a conflict between setbacks occurs, the City shall require compliance with the most stringent of the setback requirements from the various codes/regulations.

Setback Criteria for the various infiltration and dispersion facilities can be found in the design criteria for each BMP in this chapter. ***Below are conditions the soils professional must evaluate to determine the need for additional or more stringent setbacks not found in this manual.***

The professional should evaluate:

- Potential impacts to drinking water wells, septic tanks or drainfields, and springs used for public drinking water supplies. Infiltration facilities upgradient of drinking water supplies and within 1, 5, and 10-year time of travel zones must comply with Health Dept. requirements (Washington Wellhead Protection Program, DOH, 12/93).
- Potential impacts from roadways subject to deicers or herbicides which are likely to be present in the influent to the infiltration system.
- Potential impacts to all building foundations in the vicinity of the proposed infiltration facility. Recommend investigating all building foundations: within 100 feet downslope and 20 feet upslope from the facility.
- Potential impacts to all property lines within 20 feet of the facility.
- Potential impacts to a Native Growth Protection Easement (NGPE);  $\geq 20$  feet.
- Potential impacts to the top of slopes  $>15\%$  and within 50 feet.
- On-site and off-site structural stability due to extended subgrade saturation and/or head loading of the permeable layer, including the potential impacts to downgradient properties, especially on hills with known side-hill seeps.

### **SSC-2 Ground Water Protection Areas**

A site is not suitable if the infiltration facility will cause a violation of Ecology's Ground Water Quality Standards (See SSC-7 for verification testing guidance). The City shall be consulted for applicable pollutant removal requirements upstream of the infiltration facility, and to determine whether the site is located in an aquifer sensitive area, sole source aquifer, or a wellhead protection zone. See Chapter 2 of Volume I for geographic specific requirements.

### **SSC-3 High Vehicle Traffic Areas**

An infiltration BMP may be considered for runoff from areas of industrial activity and the high vehicle traffic areas described below. For such applications sufficient pollutant removal (including oil removal) shall be

provided upstream of the infiltration facility to ensure that ground water quality standards will not be violated and that the infiltration facility is not adversely affected.

High Vehicle Traffic Areas are:

- Commercial or industrial sites subject to an expected average daily traffic count (ADT)  $\geq 100$  vehicles/1,000 ft<sup>2</sup> gross building area (trip generation), and
- Road intersections with an ADT of  $\geq 25,000$  on the main roadway, or  $\geq 15,000$  on any intersecting roadway.

#### ***SSC-4 Soil Infiltration Rate/Drawdown Time***

Design to completely drain ponded runoff within 24 hours from 10-year, 24-hour recurrence frequency runoff and within 48 hours of the 100-year, 24-hour recurrence frequency runoff. In order to determine the appropriate flows from the required recurrence frequency, the Western Washington Hydrology Model (WWHM), or an appropriately calibrated continuous simulation model based on HSPF, must be used.

#### ***SSC-5 Depth to Bedrock, Water Table, or Impermeable Layer***

The base of all infiltration basins or trench systems shall be  $\geq 5$  feet above the seasonal high-water mark, bedrock (or hardpan) or other low permeability layer. A separation down to 3 feet may be considered if the ground water mounding analysis, volumetric receptor capacity, and the design of the overflow and/or bypass structures are judged by the site professional to be adequate to prevent overtopping and meet the site suitability criteria specified in this section.

#### ***SSC-6 Cold Climate and Impact of Roadway deicers***

- For cold climate design criteria (snowmelt/ice impacts) refer to D. Caraco and R. Claytor reference.
- Potential impact of roadway deicers on potable water wells must be considered in the siting determination. Mitigation measures must be implemented if infiltration of roadway deicers can cause a violation of ground water quality standards.

#### ***SSC 7-Verification Testing of the Completed Facility***

Verification testing of the completed full-scale infiltration facility is recommended to confirm that the design infiltration parameters are adequate. The site professional should determine the duration and frequency of the verification testing program including the monitoring program for the potentially impacted ground water. The ground water monitoring wells installed during site characterization (See Section 3.3.4) may be used for this purpose. Long-term (more than two years) in-situ drawdown and confirmatory monitoring of the infiltration facility would be preferable (See King County reference).



### **3.2.7 General Design, Maintenance, and Construction Criteria for Infiltration Facilities**

This section covers design, construction and maintenance criteria that apply to infiltration basins and trenches.

#### ***Design Criteria – Sizing Facilities***

The size of the infiltration facility can be determined by routing the appropriate stormwater runoff through it. To prevent the onset of anaerobic conditions, the infiltration facility must be designed to drain completely 24 hours after the flow to it has stopped.

In general, an infiltration facility would have 2 discharge modes. The primary mode of discharge from an infiltration facility is infiltration into the ground. However, when the infiltration capacity of the facility is reached, additional runoff to the facility will cause the facility to overflow. Overflows from an infiltration facility must comply with the Minimum Requirement #7 for flow control in Volume I.

In order to determine compliance with the flow control requirements, Western Washington Hydrology Model (WWHM), or an appropriately calibrated continuous simulation model based on HSPF, must be used.

When using WWHM for simulating flow through an infiltrating facility, a spreadsheet may be used to calculate infiltration rates as a function of the infiltrating surface area of the facility. A stage-area-storage-discharge table must be generated that shows the facility's storage and infiltration as a function of the stage. The table must also show the facility's overflow discharge as a function of stage. This table can be imported to the WWHM as an electronic text file, or, the table can be typed directly into the WWHM. WWHM can route the historic runoff hydrograph for the developed condition through the infiltration pond and determine if the overflow from the facility complies with flow control requirement #7.

#### **Additional Design Criteria**

- Slope of the base of the infiltration facility should be <3 percent.
- Spillways/Overflow structures- A nonerodible outlet or spillway with a firmly established elevation must be constructed to discharge overflow. Ponding depth, drawdown time, and storage volume are calculated from that reference point. Overflow Structure-Refer to Chapter 2 for design details

#### **Construction Criteria**

- Excavate infiltration trenches and basins to final grade only after construction has been completed and all upgradient soil has been stabilized. Initial basin excavation should be conducted to within 1-foot of the final elevation of the basin floor. Any accumulation of silt in the infiltration facility must be removed before putting it in service. After construction is completed, prevent sediment from entering the infiltration facility by first conveying the runoff water through an

appropriate pretreatment system such as a pre-settling basin, wet pond, or sand filter.

- Infiltration facilities should generally not be used as temporary sediment traps during construction. If an infiltration facility is to be used as a sediment trap, it must not be excavated to final grade until after the upgradient drainage area has been stabilized.
- Traffic Control - Relatively light-tracked equipment is recommended for this operation to avoid compaction of the basin floor. The use of draglines and trackhoes should be considered for constructing infiltration basins. The infiltration area should be flagged or marked to keep heavy equipment away.

### ***Maintenance Criteria***

Provision should be made for regular and perpetual maintenance of the infiltration basin/trench, with adequate access. Maintenance should be conducted when water remains in the basin or trench for more than 24 hours. An Operation and Maintenance Plan, shall be provided to ensure maintenance of the desired infiltration rate.

Debris/sediment accumulation- Removal of accumulated debris/sediment in the basin/trench should be conducted every 6 months or as needed to prevent clogging, or when water remains in the pond for greater than 24 hours at or less than design storm conditions.

Seepage Analysis and Control - Determine whether there would be any adverse effects caused by seepage zones on nearby building foundations, basements, roads, parking lots or sloping sites.

For more detailed information on maintenance, see Volume V, Section 4.6 – Maintenance Standards for Drainage Facilities.

### **Verification of Performance**

During the first 1-2 years of operation verification testing (specified in SSC-7) is recommended, along with a maintenance program designed to achieve expected performance levels. Operation verification testing may become a performance measure requirement as part of a specific permit condition. For example, a wetland permit may require specific monitoring of the performance of a BMP. Operating and maintaining ground water monitoring wells (specified in Section 3.3.6 - Site Suitability Criteria) is also strongly encouraged.

### **3.2.8 Infiltration Basins**

This section covers design and maintenance criteria specific for infiltration basins. (See schematic in Figure 3-7). Infiltration Basin design requirements are the same as those for detention pond design in Section 3.3.1. The information below is in addition to the design requirements of section 3.3.1.

**Description:**

Infiltration basins are earthen impoundments used for the collection, temporary storage and infiltration of incoming stormwater runoff.

**Design Criteria specific for Basins**

- Access should be provided for vehicles to easily maintain the forebay (presettling basin) area and not disturb vegetation, or resuspend sediment any more than is absolutely necessary.
- A minimum of one foot of freeboard is recommended when establishing the design ponded water depth. Freeboard is measured from the rim of the infiltration facility to the maximum ponding level or from the rim down to the overflow point if overflow or a spillway is included.
- Lining Material - Basins can be open or covered with a 6 to 12-inch layer of filter material such as coarse sand, or a suitable filter fabric to help prevent the buildup of impervious deposits on the soil surface. A nonwoven geotextile should be selected that will function sufficiently without plugging (see geotextile specifications in Appendix V-C of Volume V). The filter layer can be replaced or cleaned when/if it becomes clogged.
- Vegetation - The embankment, emergency spillways, spoil and borrow areas, and other disturbed areas should be stabilized and planted, preferably with grass, in accordance with Stormwater Site Plan (See Minimum Requirement #1 of Volume I). Without healthy vegetation the surface soil pores would quickly plug.
- Infiltration basins, which use berms to impound 10 acre-feet or more, are subject to the state's dam safety requirements. Refer to Section 3.3.1 for a discussion of dam safety requirements as they apply to detention basins.

**Setback Criteria for Infiltration Basins**

The setback requirements for infiltration basins are the same as those for detention ponds. Please refer to Section 3.3.1 – Detention Ponds for setback requirements.

**Maintenance Criteria for Basins**

- Maintain basin floor and side slopes to promote dense turf with extensive root growth. This enhances infiltration, prevents erosion and consequent sedimentation of the basin floor, and prevents invasive weed growth. Bare spots are to be immediately stabilized and revegetated.
- Vegetation growth should not be allowed to exceed 18 inches in height. Mow the slopes periodically and check for clogging, and erosion.
- Seed mixtures should be the same as those recommended in Table 3.5. The use of slow-growing, stoloniferous grasses will permit long intervals between mowing. Mowing twice a year is generally

satisfactory. Fertilizers should be applied only as necessary and in limited amounts to avoid contributing to ground water pollution. Consult the City for appropriate fertilizer types, including slow release fertilizers, and application rates.

### **3.2.9 Infiltration Trenches**

This section covers design, construction, and maintenance criteria specific for infiltration trenches.

#### ***Description:***

Infiltration trenches are generally at least 24 inches wide, and are backfilled with a coarse stone aggregate, allowing for temporary storage of stormwater runoff in the voids of the aggregate material. Stored runoff then gradually infiltrates into the surrounding soil. The surface of the trench can be covered with grating and/or consist of stone, gabion, sand, or a grassed covered area with a surface inlet. Perforated rigid pipe of at least 8-inch diameter can also be used to distribute the stormwater in a stone trench.

See Figures 3-9 for schematic of an infiltration trench. See Figures 3-10, 3-11, 3-12, and 3-13 for examples of trench designs.

#### ***Design Criteria***

- Due to accessibility and maintenance limitations infiltration trenches must be carefully designed and constructed. The City should be contacted prior to the start of construction for additional specifications.
- Include an access port or open or grated top for accessibility to conduct inspections and maintenance.
- Backfill Material - The aggregate material for the infiltration trench shall consist of a clean aggregate with a maximum diameter of 3 inches and a minimum diameter of 1.5 inches. Void space for these aggregates should be in the range of 30 to 40 percent.
- Geotextile fabric liner - The aggregate fill material shall be completely encased in an engineering geotextile material. In the case of an aggregate surface, geotextile should surround all of the aggregate fill material except for the top one-foot, which is placed over the geotextile. Geotextile fabric with acceptable properties must be carefully selected to avoid plugging (see Appendix V-C of Volume V).
- The bottom sand or geotextile fabric as shown in the attached figures is optional.

*Refer to the Federal Highway Administration Manual "Geosynthetic Design and Construction Guidelines," Publication No. FHWA HI-95-038, May 1995 for design guidance on geotextiles in drainage applications. Refer to the NCHRP Report 367, "Long-Term Performance of Geosynthetics in Drainage Applications," 1994, for long-term performance data and background on the potential for geotextiles to clog, blind, or to allow piping to occur and how to design for these issues.*

- Overflow Channel - Because an infiltration trench is generally used for small drainage areas, an emergency spillway is not necessary. However, a non-erosive overflow channel leading to a stabilized watercourse should be provided at the one-day drawdown level.
- Surface Cover-A stone filled trench can be placed under a porous or impervious surface cover to conserve space.
- Observation Well - An observation well shall be installed at the lower end of the infiltration trench to check water levels, drawdown time, sediment accumulation, and conduct water quality monitoring. Figure 3-14 illustrates observation well details. It should consist of a perforated PVC pipe which is 4 to 6 inches in diameter and it should be constructed flush with the ground elevation. For larger trenches a 12-36 inch diameter well can be installed to facilitate maintenance operations such as pumping out the sediment. The top of the well should be capped to discourage vandalism and tampering.

### **Construction Criteria**

- Trench Preparation -Excavated materials must be placed away from the trench sides to enhance trench wall stability. Care should also be taken to keep this material away from slopes, neighboring property, sidewalks and streets. It is recommended that this material be covered with plastic. (see Erosion/sediment control Criteria in Volume II).
- Stone Aggregate Placement and Compaction - The stone aggregate should be placed in lifts and compacted using plate compactors. As a rule of thumb, a maximum loose lift thickness of 12 inches is recommended. The compaction process ensures geotextile conformity to the excavation sides, thereby reducing potential piping and geotextile clogging, and settlement problems.
- Potential Contamination - Prevent natural or fill soils from intermixing with the stone aggregate. All contaminated stone aggregate must be removed and replaced with uncontaminated stone aggregate.
- Overlapping and Covering - Following the stone aggregate placement, the geotextile must be folded over the stone aggregate to form a 12 inch minimum longitudinal overlap. When overlaps are required between rolls, the upstream roll should overlap a minimum of 2 feet over the downstream roll in order to provide a shingled effect.
- Voids behind Geotextile - Voids between the geotextile and excavation sides must be avoided. Removing boulders or other obstacles from the trench walls eliminates one source of such voids. Natural soils should be placed in these voids at the most convenient time during construction to ensure geotextile conformity to the excavation sides. Soil piping, geotextile clogging, and possible surface subsidence will be avoided by this remedial process.

- Unstable Excavation Sites - Vertically excavated walls may be difficult to maintain in areas where the soil moisture is high or where soft or cohesionless soils predominate. Trapezoidal, rather than rectangular, cross-sections may be needed.

**Setback Criteria**

Please refer to Section 3.1.1 for infiltration trench setbacks.

**Maintenance Criteria**

- Sediment buildup in the top foot of stone aggregate or the surface inlet should be monitored on the same schedule as the observation well.

**3.3 Detention Facilities**

This section presents the methods, criteria, and details for design and analysis of detention facilities. These facilities provide for the temporary storage of increased surface water runoff resulting from development pursuant to the performance standards set forth in Minimum Requirement #7 for flow control (Volume I).

There are three primary types of detention facilities described in this section: detention ponds, tanks, and vaults.

**3.3.1 Detention Ponds**

The design criteria in this section are for detention ponds. However, many of the criteria also apply to infiltration ponds (Section 3.3 and Volume V), and water quality wetponds and combined detention/wetponds (Volume V).

***Dam Safety for Detention BMPs***

Stormwater detention facilities that can impound 10 acre-feet (435,600 cubic feet; 3.26 million gallons) or more above normal, surrounding grade with the water level at the embankment crest are subject to the state's dam safety requirements, even if water storage is intermittent and infrequent (WAC 173-175-020(1)). The principal safety concern is for the downstream population at risk if the dam should breach and allow an uncontrolled release of the pond contents. Peak flows from dam failures are typically much larger than the 100-year flows which these ponds are typically designed to accommodate.

Stormwater detention facilities subject to the state's dam safety requirements must size the emergency spillway to accommodate the runoff from the dam safety design storm without overtopping the dam.

In addition to the hydrologic and hydraulic issues related to precipitation and runoff, other dam safety requirements include geotechnical issues, construction inspection and documentation, dam breach analysis, inundation mapping, emergency action planning, and periodic inspections by project owners and by Dam Safety engineers. All of these requirements, plus procedural requirements for plan review and approval and payment of construction permit fees are described in detail in

guidance documents developed by and available from the Dam Safety Office.

In addition to the written guidance documents, Dam Safety engineers are available to provide technical assistance to project owners and design engineers in understanding and addressing the dam safety requirements for their specific project. In the interest of providing a smooth integration of dam safety requirements into the stormwater detention project and streamlining Dam Safety's engineering review and issuance of the construction permit, it is recommended and requested that Dam Safety be contacted early in the facilities planning process. The Dam Safety Office is located in the Ecology headquarters building in Lacey. [Electronic versions of the guidance documents in PDF format are available on the Department of Ecology Web site.](#)

### **Design Criteria**

Standard details for detention ponds are shown in Figure 3-15 through Figure 3-18. Control structure discussion and details are provided in Section 3.3.4.

#### **General**

1. Ponds must be designed as flow-through systems (however, parking lot storage may be utilized through a back-up system; see Section 3.3.5). Developed flows must enter through a conveyance system separate from the control structure and outflow conveyance system. Maximizing distance between the inlet and outlet is encouraged to promote sedimentation.
2. Pond bottoms should be level and be located a minimum of 0.5 foot below the inlet and outlet to provide sediment storage.
3. Design guidelines for outflow control structures are specified in Section 3.3.4.
4. A geotechnical analysis and report must be prepared for steep slopes (i.e., slopes over 15%), or if located within 200 feet of the top of a steep slope or landslide hazard area. The scope of the geotechnical report should include the assessment of impoundment seepage on the stability of the natural slope where the facility will be located within the setback limits set forth in this section.

#### **Side Slopes**

1. Interior side slopes up to the emergency overflow water surface should not be steeper than 3H:1V unless a fence is provided (see "Fencing").
2. Exterior side slopes must not be steeper than 2H:1V unless analyzed for stability by a geotechnical engineer.
3. Pond walls may be vertical retaining walls, provided: (a) they are constructed of reinforced concrete per Section 3.3.3, Material; (b) a fence is provided along the top of the wall; (c) the entire pond perimeter may be retaining walls, however, it is recommended that at least 25 percent of the pond perimeter be a vegetated soil slope not steeper than 3H:1V; (d) access for maintenance per this section and Section

4.8 shall be provided and (e) the design is stamped by a licensed civil engineer with structural expertise. Other retaining walls such as rockeries, concrete, masonry unit walls, and keystone type wall may be used if designed by a geotechnical engineer or a civil engineer with structural expertise. If the entire pond perimeter is to be retaining walls, ladders should be provided on the walls for safety reasons.

### **Embankments**

1. Pond berm embankments higher than 6 feet must be designed by a professional engineer with geotechnical expertise.
2. For berm embankments 6 feet or less in height, the minimum top width should be 6 feet or as recommended by a geotechnical engineer.
3. Pond berm embankments must be constructed on native consolidated soil (or adequately compacted and stable fill soils analyzed by a geotechnical engineer) free of loose surface soil materials, roots, and other organic debris.
4. Pond berm embankments greater than 4 feet in height must be constructed by excavating a key equal to 50 percent of the berm embankment cross-sectional height and width unless specified otherwise by a geotechnical engineer.
5. Embankment compaction should be accomplished in such a manner as to produce a dense, low permeability engineered fill that can tolerate post-construction settlements with a minimum of cracking. The embankment fill should be placed on a stable subgrade and compacted to a minimum of 95% of the Standard Proctor Maximum Density, ASTM Procedure D698. Placement moisture content should lie within 1% dry to 3% wet of the optimum moisture content. The referenced compaction standard may have to be increased to comply with local regulations.

The berm embankment should be constructed of soils with the following characteristics per the United States Department of Agriculture's Textural Triangle: a minimum of 20% silt and clay, a maximum of 60% sand, a maximum of 60% silt, with nominal gravel and cobble content. Soils outside this specified range may be used, provided the design satisfactorily addresses the engineering concerns posed by these soils. The paramount concerns with these soils are their susceptibility to internal erosion or piping and to surface erosion from wave action and runoff on the upstream and downstream slopes, respectively. *Note: In general, excavated glacial till is well suited for berm embankment material.*

6. Anti-seepage filter-drain diaphragms must be placed on outflow pipes in berm embankments impounding water with depths greater than 8 feet at the design water surface. See Dam Safety Guidelines, Part IV, Section 3.3.B on pages 3-27 to 3-30. An electronic version of the Dam Safety Guidelines is available in PDF format at [www.ecy.wa.gov/programs/wr/dams/dss.html](http://www.ecy.wa.gov/programs/wr/dams/dss.html).



## Overflow

1. In all ponds, tanks, and vaults, a primary overflow (usually a riser pipe within the control structure; see Section 3.3.4) must be provided to bypass the 100-year developed peak flow over or around the restrictor system. This assumes the facility will be full due to plugged orifices or high inflows; the primary overflow is intended to protect against breaching of a pond embankment (or overflows of the upstream conveyance system in the case of a detention tank or vault). The design must provide controlled discharge directly into the downstream conveyance system or another acceptable discharge point.
2. A secondary inlet to the control structure must be provided in ponds as additional protection against overtopping should the inlet pipe to the control structure become plugged. A grated opening (“jailhouse window”) in the control structure manhole functions as a weir (see Figure 3-16) when used as a secondary inlet. *Note: The maximum circumferential length of this opening must not exceed one-half the control structure circumference.*

The “birdcage” overflow structure as shown in Figure 3-17 may also be used as a secondary inlet.

## Emergency Overflow Spillway

1. In addition to the above overflow provisions, ponds must have an emergency overflow spillway. For impoundments of 10 acre-feet or greater, the emergency overflow spillway must meet the state’s dam safety requirements (see above). For impoundments under 10 acre-feet, ponds must have an emergency overflow spillway that is sized to pass the 100-year developed peak flow in the event of total control structure failure (e.g., blockage of the control structure outlet pipe) or extreme inflows. Emergency overflow spillways are intended to control the location of pond overtopping and direct overflows back into the downstream conveyance system or other acceptable discharge point.
2. As an option for ponds with berms less than 2 feet in height and located at grades less than 5 percent, emergency overflow may be provided by an emergency overflow structure, such as a Type II manhole fitted with a birdcage as shown in Figure 3-17. The emergency overflow structure must be designed to pass the 100-year developed peak flow, with a minimum 6 inches of freeboard, directly to the downstream conveyance system or another acceptable discharge point. Where an emergency overflow spillway would discharge to a steep slope, consideration should be given to providing an emergency overflow structure *in addition to* the spillway.
3. The emergency overflow spillway must be armored with riprap in conformance with the “Outlet Protection” BMP in Volume II. The spillway must be armored full width, beginning at a point midway across the berm embankment and extending downstream to where emergency overflows re-enter the conveyance system (see Figure 3-16).

4. Emergency overflow spillway designs must be analyzed as broad-crested trapezoidal weirs as described in Methods of Analysis at the end of this section (Section 3.3.1). Either one of the weir sections shown in Figure 3-16 may be used.

### **Access**

The following guidelines for access shall be used.

1. Maintenance access road(s) shall be provided to the control structure and other drainage structures associated with the pond (e.g., inlet or bypass structures). It is recommended that manhole and catch basin lids be in or at the edge of the access road and at least five feet from a property line.
2. An access ramp is needed for removal of sediment with a trackhoe and truck. The ramp must extend to the pond bottom if the pond bottom is greater than 1,500 square feet (measured without the ramp) and it may end at an elevation 4 feet above the pond bottom, if the pond bottom is less than 1,500 square feet (measured without the ramp).

On large, deep ponds, truck access to the pond bottom via an access ramp is necessary so loading can be done in the pond bottom. On small deep ponds, the truck can remain on the ramp for loading. On small shallow ponds, a ramp to the bottom may not be required if the trackhoe can load a truck parked at the pond edge or on the internal berm of a wetpond or combined pond (trackhoes can negotiate interior pond side slopes).

3. The internal berm of a wetpond or combined detention and wetpond may be used for access if it is no more than 4 feet above the first wetpool cell, if the first wetpool cell is less than 1,500 square feet (measured without the ramp), and if it is designed to support a loaded truck, considering the berm is normally submerged and saturated.
4. Access ramps must meet the requirements for design and construction of access roads specified below.
5. If a fence is required, access should be limited by a double-posted gate. If a fence is not required, access should be limited by bollards – that is, two fixed bollards on each side of the access road and two removable bollards equally located between the fixed bollards.
6. Additional easements or modification to proposed lot boundaries may be required to provide adequate access to detention facilities. Right-of-way may be needed for detention pond maintenance. Any tract not abutting public right-of-way shall have a 15-foot wide extension of the tract to an acceptable access location.

### **Design of Access Roads**

The design guidelines for access road are given below.

1. Access roads may be constructed with an asphalt or gravel surface, or modular grid pavement. All surfaces must conform to the City standards and manufacturer's specifications.
2. Maximum grade shall be 15 percent.
3. Outside turning radius should be a minimum of 40 feet.
4. Fence gates should be located only on straight sections of road.
5. Access roads should be 15 feet in width on curves and 12 feet on straight sections.
6. A driveway meeting City Design standards must be provided where access roads connect to paved public roadways.

### **Fencing**

1. A fence is needed at the emergency overflow water surface elevation, or higher, where a pond interior side slope is steeper than 3H:1V, or where the impoundment is a wall greater than 24 inches in height. The fence need only be constructed for those slopes steeper than 3H:1V. Note, however, that other regulations such as the Uniform Building Code may require fencing of vertical walls. If more than 10 percent of slopes are steeper 3H:1V, it is recommended that the entire pond be fenced.

Also note that detention ponds on school sites will need to comply with safety standards developed by the Department of Health (DOH) and the Superintendent for Public Instruction (SPI). These standards include what is called a 'non-climbable fence.' One example of a non-climbable fence is a chain-link fence with a tighter mesh, so children cannot get a foot-hold for climbing. For school sites, and possibly for parks and playgrounds, the designer should consult the DOH's Office of Environmental Programs.

A fence is needed to discourage access to portions of a pond where steep side slopes (steeper than 3:1) increase the potential for slipping into the pond. Fences also serve to guide those who have fallen into a pond to side slopes that are flat enough (flatter than 3:1 and unfenced) to allow for easy escape.

2. Fences shall be 6 feet in height. For example designs, see WSDOT Standard Plan L-2, Type 1 or Type 3 chain link fence. The fence may be a minimum of 4 feet in height if the depth of the impoundment (measured from the lowest elevation in the bottom of the impoundment, directly adjacent to the bottom of the fenced slope, up to the emergency overflow water surface) is 5 feet or less. For example designs, see WSDOT Standard Plan L-2, Type 4 or Type 6 chain link fence.
3. Access road gates may be 16 feet in width consisting of two swinging sections 8 feet in width. Additional vehicular access gates may be needed to facilitate maintenance access.
4. Pedestrian access gates (if needed) should be 4 feet in width.

5. Vertical metal balusters or 9 gauge galvanized steel fabric with bonded vinyl coating can be used as fence material. For steel fabric fences, the following aesthetic features may be considered:
  - a) Vinyl coating that is compatible with the surrounding environment (e.g., green in open, grassy areas and black or brown in wooded areas). All posts, cross bars, and gates may be painted or coated the same color as the vinyl clad fence fabric.
  - b) Fence posts and rails that conform to WSDOT Standard Plan L-2 for Types 1, 3, or 4 chain link fence.
6. For metal baluster fences, Uniform Building Code standards apply.
7. Wood fences may be used in subdivisions where the fence will be maintained by homeowners associations or adjacent lot owners.
8. Wood fences shall have pressure treated posts (ground contact rated) either set in 24-inch deep concrete footings or attached to footings by galvanized brackets. Rails and fence boards may be cedar, pressure-treated fir, or hemlock.

### **Signage**

Detention ponds, infiltration ponds, wetponds, and combined ponds should have a sign placed for maximum visibility from adjacent streets, sidewalks, and paths. An example of sign specifications for a permanent surface water control pond is illustrated in Figure 3-18.

### **Setbacks**

The City requires specific setbacks for sites with steep slopes, land slide areas, open water features, springs, wells, and septic tank drain fields. Adequate room for maintenance access and equipment shall also be considered. Project proponents should consult the Tacoma Municipal Codes to determine all applicable setback requirements. Where a conflict between setbacks occurs, the City shall require compliance with the most stringent of the setback requirements from the various codes/regulations. Setbacks shall be as follows or may be determined by a qualified geotechnical engineer:

1. Stormwater ponds shall be set back at least 100 feet from drinking water wells, septic tanks or drainfields, and springs used for public drinking water supplies. Infiltration facilities upgradient of drinking water supplies and within 1, 5, and 10-year time of travel zones must comply with Health Dept. requirements (Washington Wellhead Protection Program, DOH, 12/93).
2. All ponds shall be at least 10 feet from any structure or property line. If necessary, setbacks shall be increased from the minimum 10 feet in order to maintain a 1:1 side slope for future excavation and maintenance. *Note: Vertical pond walls may necessitate an increase in setbacks.*
3. All pond system shall be setback from sensitive areas, steep slopes, landslide hazard areas, and erosion hazard areas as governed by the Tacoma Municipal Code. Facilities near landslide hazard areas must be evaluated by a geotechnical engineer or qualified geologist. The

discharge point shall not be placed on or above slopes greater than 20% or above erosion hazard areas without evaluation by a geotechnical engineer or qualified geologist and City approval.

4. For sites with septic systems, ponds shall be downgradient of the drainfield unless the site topography clearly prohibits subsurface flows from intersecting the drainfield.

### **Seeps and Springs**

Intermittent seeps along cut slopes are typically fed by a shallow groundwater source (interflow) flowing along a relatively impermeable soil stratum. These flows are storm driven. However, more continuous seeps and springs, which extend through longer dry periods, are likely from a deeper groundwater source. When continuous flows are intercepted and directed through flow control facilities, adjustments to the facility design may have to be made to account for the additional base flow (unless already considered in design). Where continuous flows are intercepted, flow monitoring may be required to determine flows for design purposes.

### **Planting Requirements**

Exposed earth on the pond bottom and interior side slopes should be sodded or seeded with an appropriate seed mixture. All remaining areas of the tract should be planted with grass or be landscaped and mulched with a 4-inch cover of hog fuel or shredded wood mulch. Shredded wood mulch is made from shredded tree trimmings, usually from trees cleared on site. The mulch should be free of garbage and weeds and should not contain excessive resin, tannin, or other material detrimental to plant growth. Multiple plantings and mulching may be required until vegetation has established itself. A bond may be required to guarantee vegetation stabilization for detention facilities.

### **Landscaping**

Landscaping is encouraged for most stormwater tract areas (see below for areas not to be landscaped). However, if provided, landscaping should adhere to the criteria that follow so as not to hinder maintenance operations. Landscaped stormwater tracts may, in some instances, provide a recreational space. In other instances, "naturalistic" stormwater facilities may be placed in open space tracts.

The following guidelines should be followed if landscaping is proposed for facilities.

1. No trees or shrubs may be planted within 10 feet of inlet or outlet pipes or manmade drainage structures such as spillways or flow spreaders. Species with roots that seek water, such as willow or poplar, should be avoided within 50 feet of pipes or manmade structures.
2. Planting should be restricted on berms that impound water either permanently or temporarily during storms. This restriction does not apply to cut slopes that form pond banks, only to berms.
  - a) Trees or shrubs may not be planted on portions of water-impounding berms taller than four feet high. Only grasses may be planted on berms taller than four feet.

Grasses allow unobstructed visibility of berm slopes for detecting potential dam safety problems such as animal burrows, slumping, or fractures in the berm.

- b) Trees planted on portions of water-impounding berms less than 4 feet high must be small, not higher than 20 feet mature height, and have a fibrous root system. Table 3.4 gives some examples of trees with these characteristics developed for the central Puget Sound.

These trees reduce the likelihood of blow-down trees, or the possibility of channeling or piping of water through the root system, which may contribute to dam failure on berms that retain water.

*Note: The internal berm in a wetpond is not subject to this planting restriction since the failure of an internal berm would be unlikely to create a safety problem.*

- 3. All landscape material, including grass, should be planted in good topsoil. Native underlying soils may be made suitable for planting if amended with 4 inches of well-aged compost tilled into the subgrade. Compost used should meet specifications for Grade A compost quality as described in Ecology publication 94-38.
- 4. Soil in which trees or shrubs are planted may need additional enrichment or additional compost top-dressing. Consult a nurseryman, landscape professional, or arborist for site-specific recommendations.
- 5. For a naturalistic effect as well as ease of maintenance, trees or shrubs should be planted in clumps to form “*landscape islands*” rather than evenly spaced.
- 6. The landscaped islands should be a minimum of six feet apart, and if set back from fences or other barriers, the setback distance should also be a minimum of 6 feet. Where tree foliage extends low to the ground, the six feet setback should be counted from the outer drip line of the trees (estimated at maturity).

This setback allows a 6-foot wide mower to pass around and between clumps.

- 7. Evergreen trees and trees which produce relatively little leaf-fall (such as Oregon ash, mimosa, or locust) are preferred in areas draining to the pond.
- 8. Trees should be set back so that branches do not extend over the pond (to prevent deposition of leaves into the pond).
- 9. Drought tolerant species are recommended.

**Guidelines for Naturalistic Planting.** Stormwater facilities may sometimes be located within open space tracts if “natural appearing.” Two generic kinds of naturalistic planting are outlined below, but other options are also possible. Native vegetation is preferred in naturalistic plantings.

**Open Woodland.** In addition to the general landscaping guidelines above, the following are recommended.

1. Landscaped islands (when mature) should cover a minimum of 30 percent or more of the tract, exclusive of the pond area.
2. Tree clumps should be underplanted with shade-tolerant shrubs and groundcover plants. The goal is to provide a dense understory that need not be weeded or mowed.
3. Landscaped islands should be placed at several elevations rather than “ring” the pond, and the size of clumps should vary from small to large to create variety.
4. Not all islands need to have trees. Shrub or groundcover clumps are acceptable, but lack of shade should be considered in selecting vegetation.

*Note: Landscaped islands are best combined with the use of wood-based mulch (hog fuel) or chipped onsite vegetation for erosion control (only for slopes above the flow control water surface). It is often difficult to sustain a low-maintenance understory if the site was previously hydroseeded. Compost or composted mulch (typically used for constructed wetland soil) can be used below the flow control water surface (materials that are resistant to and preclude flotation). The method of construction of soil landscape systems can also cause natural selection of specific plant species. Consult a soil restoration or wetland soil scientist for site-specific recommendations.*

**Northwest Savannah or Meadow.** In addition to the general landscape guidelines above, the following are recommended.

1. Landscape islands (when mature) should cover 10 percent or more of the site, exclusive of the pond area.
2. Planting groundcovers and understory shrubs is encouraged to eliminate the need for mowing under the trees when they are young.
3. Landscape islands should be placed at several elevations rather than “ring” the pond.

The remaining site area should be planted with an appropriate grass seed mix, which may include meadow or wildflower species. Native or dwarf grass mixes are preferred. Table 3.5 gives an example of dwarf grass mix developed for central Puget Sound. Grass seed should be applied at 2.5 to 3 pounds per 1,000 square feet.

*Note: Amended soil or good topsoil is required for all plantings.*

Creation of areas of emergent vegetation in shallow areas of the pond is recommended. Native wetland plants, such as sedges (*Carex* sp.), bulrush (*Scirpus* sp.), water plantain (*Alisma* sp.), and burreed (*Sparganium* sp.) are recommended. If the pond does not hold standing water, a clump of wet-tolerant, non-invasive shrubs, such as salmonberry or snowberry, is recommended below the detention design water surface.

*Note: This landscape style is best combined with the use of grass or sod for site stabilization and erosion control.*

**Seed Mixes.** The seed mixes listed below were developed for central Puget Sound.

## **Maintenance**

**General.** Maintenance is of primary importance if detention ponds are to continue to function as originally designed. A local government, a designated group such as a homeowners' association, or some individual must accept the responsibility for maintaining the structures and the impoundment area. A specific maintenance plan must be formulated outlining the schedule and scope of maintenance operations. Debris removal in detention basins can be achieved through the use of trash racks or other screening devices.

All private drainage systems serving multiple lots shall require a signed Covenant and Easement agreement with the City. The agreement shall designate the systems to be maintained and the parties responsible for maintenance. Contact the City to determine the applicability of this requirement to a project.

Design with maintenance in mind. Provisions to facilitate maintenance operations must be built into the project when it is installed. Maintenance must be a basic consideration in design and in determination of first cost. See Table 3.6 for specific maintenance requirements.

Any standing water removed during the maintenance operation must be disposed of in a City approved manner. See the dewatering requirements in Volume II of this City's Surface Water Manual. *Pretreatment may be necessary.* Residuals must be disposed in accordance with state and local solid waste regulations (See Minimum Functional Standards For Solid Waste Handling, Chapter 173-304 WAC).

**Vegetation.** If a shallow marsh is established, then periodic removal of dead vegetation may be necessary. Since decomposing vegetation can release pollutants captured in the wet pond, especially nutrients, it may be necessary to harvest dead vegetation annually prior to the winter wet season. Otherwise, the decaying vegetation may export pollutants out of the pond or interfere with operation of the facility. If harvesting is to be done in the wetland, a written harvesting procedure should be prepared by a wetland scientist and submitted with the drainage design to the City.

**Sediment.** Maintenance of sediment forebays where provided, and attention to sediment accumulation within the pond is extremely important. Sediment deposition should be continually monitored in the basin. Owners, operators, and maintenance personnel should be aware that significant concentrations of metals (e.g., lead, zinc, and cadmium) as well as some organics such as pesticides, may be expected to accumulate at the bottom of these flow control facilities. Testing of sediment, especially near points of inflow, should be conducted regularly



to determine the leaching potential and level of accumulation of potentially hazardous material before disposal.

### **Methods of Analysis**

**Detention Volume and Outflow.** The volume and outflow design for detention ponds must be in accordance with Minimum Requirements #7 in Volume I and the hydrologic analysis and design methods in Chapter 1 of this Volume. Design guidelines for restrictor orifice structures are given in Section 3.3.4.

*Note: The design water surface elevation is the highest elevation which occurs in order to meet the required outflow performance for the pond.*

**Detention Ponds in Infiltrative Soils.** Detention ponds may occasionally be sited on till soils that are sufficiently permeable for a properly functioning infiltration system (see Section 3.2). These detention ponds have a surface discharge and may also utilize infiltration as a second pond outflow. Detention ponds sized with infiltration as a second outflow must meet all the requirements of Section 3.2 for infiltration ponds, including a soils report, testing, groundwater protection, pre-settling, and construction techniques.

**Emergency Overflow Spillway Capacity.** For impoundments under 10-acre-feet, or ponds not subject to dam safety requirements, the emergency overflow spillway weir section must be designed to pass the 100-year runoff event for developed conditions assuming a broad-crested weir. The **broad-crested weir equation** for the spillway section in Figure 3-19, for example, would be:

$$Q_{100} = C (2g)^{1/2} \left[ \frac{2}{3} LH^{3/2} + \frac{8}{15} (\text{Tan } \theta) H^{5/2} \right] \quad (\text{equation 1})$$

Where  $Q_{100}$  = peak flow for the 100-year runoff event (cfs)  
 $C$  = discharge coefficient (0.6)  
 $g$  = gravity (32.2 ft/sec<sup>2</sup>)  
 $L$  = length of weir (ft)  
 $H$  = height of water over weir (ft)  
 $\theta$  = angle of side slopes

Assuming  $C = 0.6$  and  $\text{Tan } \theta = 3$  (for 3:1 slopes), the equation becomes:

$$Q_{100} = 3.21[LH^{3/2} + 2.4 H^{5/2}] \quad (\text{equation 2})$$

To find width  $L$  for the weir section, the equation is rearranged to use the computed  $Q_{100}$  and trial values of  $H$  (0.2 feet minimum):

$$L = [Q_{100}/(3.21H^{3/2})] - 2.4 H \quad \text{or} \quad 6 \text{ feet minimum} \quad (\text{equation 3})$$

### **3.3.2 Detention Tanks**

*Detention tanks* are underground storage facilities typically constructed with large diameter pipe. Standard detention tank details are shown in Figure 3-20 and Figure 3-21. Control structure details are shown in Section 3.3.4.

## Design Criteria

**General.** Typical design guidelines are as follows:

1. Tanks may be designed as flow-through systems with manholes in line (see Figure 3-20) to promote sediment removal and facilitate maintenance. Tanks may also be designed to allow stormwater to back-up into the system. This is allowable if the tank is preceded by water quality facilities, since little sediment should reach the inlet/control structure and low head losses can be expected because of the proximity of the inlet/control structure to the tank
2. The detention tank bottom should be located 1 foot below the inlet and outlet to provide dead storage for sediment. If arch pipe is used the minimum dead storage is 0.5 feet.
3. The minimum pipe diameter for a detention tank is 36 inches.
4. Tanks larger than 36 inches may be connected to each adjoining structure with a short section (2-foot maximum length) of 36-inch minimum diameter pipe. These sections shall not be considered as access when determining required access points.
5. Details of outflow control structures are given in Section 3.2.4.

*Note: Control and access manholes should have additional ladder rungs to allow ready access to all tank access pipes when the catch basin sump is filled with water (see Figure 3-21, plan view).*

**Materials.** Galvanized metals leach zinc into the environment, especially in standing water situations. This can result in zinc concentrations that can be toxic to aquatic life. Therefore, use of galvanized materials in stormwater facilities and conveyance systems is discouraged. Where other metals, such as aluminum or stainless steel, or plastics are available, they should be used. If galvanized metal pipes are used for detention tanks, they shall employ a protective asphalt coating.

Pipe material, joints, and protective treatment for tanks should be in accordance with Section 9.05 of the *WSDOT/APWA Standard Specification*.

**Structural Stability.** Tanks must meet structural requirements for overburden support and traffic loading if appropriate. H-20 live loads shall be accommodated for tanks lying under parking areas and access roads. Metal tank end plates shall be designed for structural stability at maximum hydrostatic loading conditions. Flat end plates generally require thicker gage material than the pipe and/or require reinforcing ribs. Tanks shall be placed on stable, well consolidated native material with a suitable bedding. Tanks shall not be placed in fill slopes, unless analyzed in a geotechnical report for stability and constructability.

**Buoyancy.** In moderately pervious soils where seasonal groundwater may induce flotation, buoyancy tendencies shall be balanced either by ballasting with backfill or concrete backfill, providing concrete anchors, increasing the total weight, or providing subsurface drains to permanently lower the groundwater table. Calculations that demonstrate stability must be documented.

**Access.** The following guidelines for access shall be used along with those stipulated in Section 3.3.1.

1. The maximum depth from finished grade to tank invert shall be 20 feet.
2. Access openings should be positioned a maximum of 50 feet from any location within the tank. A minimum of one access opening per tank shall be provided.
3. All tank access openings shall have round, solid locking lids (usually 1/2 to 5/8-inch diameter Allen-head cap screws).
4. Thirty-six-inch minimum diameter CMP riser-type manholes (Figure 3-21) of the same gage as the tank material may be used for access along the length of the tank and at the upstream terminus of the tank in a backup system. The top slab is separated (1-inch minimum gap) from the top of the riser to allow for deflections from vehicle loadings without damaging the riser tank.
5. All tank access openings must be readily accessible by maintenance vehicles.
6. Tanks must comply with the OSHA confined space requirements, which includes clearly marking entrances to confined space areas. This may be accomplished by hanging a removable sign in the access riser(s), just under the access lid.

**Access Roads.** Access roads are needed to all detention tanks, control structures, and risers. The access roads must be designed and constructed as specified for detention ponds in Section 3.3.1.

**Setbacks.** For Setback Requirements See Section 3.3.1.

**Maintenance.** Provisions to facilitate maintenance operations must be built into the project when it is installed. Maintenance must be a basic consideration in design and in determination of first cost. See Table 3.7 for specific maintenance requirements.

## **Methods of Analysis**

### **Detention Volume and Outflow**

The volume and outflow design for detention tanks must be in accordance with Minimum Requirement #7 in Volume I and the hydrologic analysis and design methods in Chapter 2. Restrictor and orifice design are given in Section 3.3.4.

### **3.3.3 Detention Vaults**

*Detention vaults* are box-shaped underground storage facilities typically constructed with reinforced concrete. A standard detention vault detail is shown in Figure 3-22. Control structure details are shown in Section 3.3.4.

## **Design Criteria**

**General.** Typical design guidelines are as follows:

1. Detention vaults may be designed as flow-through systems with bottoms level (longitudinally) or sloped toward the inlet to facilitate sediment removal. Distance between the inlet and outlet should be maximized (as feasible).

2. The detention vault bottom may slope at least 5 percent from each side towards the center, forming a broad “v” to facilitate sediment removal. More than one “v” may be used to minimize vault depth. However, the vault bottom may be flat with 0.5-1 foot of sediment storage if removable panels are provided over the entire vault. It is recommended that the removable panels be at grade, have stainless steel lifting eyes, and weigh no more than 5 tons per panel.
3. The invert elevation of the outlet should be elevated above the bottom of the vault to provide an average 6 inches of sediment storage over the entire bottom. The outlet should also be elevated a minimum of 2 feet above the orifice to retain oil within the vault.
4. Details of outflow control structures are given in Section 3.3.4.

**Materials.** Minimum 3,000 psi structural reinforced concrete may be used for detention vaults. All construction joints must be provided with water stops.

**Structural Stability.** All vaults must meet structural requirements for overburden support and H-20 traffic loading (See Standard Specifications for Highway Bridges, 1998 Interim Revisions, American Association of State Highway and Transportation Officials). Vaults located under roadways must meet any live load requirements of the City. Cast-in-place wall sections must be designed as retaining walls. Structural designs for cast-in-place vaults must be stamped by a licensed civil engineer with structural expertise. Vaults must be placed on stable, well-consolidated native material with suitable bedding. Vaults must not be placed in fill slopes, unless analyzed in a geotechnical report for stability and constructability.

**Access.** Access must be provided over the inlet pipe and outlet structure. The following guidelines for access may be used.

1. Access openings should be positioned a maximum of 50 feet from any location within the vault. Additional access points may be needed on large vaults. If more than one “v” is provided in the vault floor, access to each “v” must be provided.
2. For vaults with greater than 1,250 square feet of floor area, a 5' by 10' removable panel should be provided over the inlet pipe (instead of a standard frame, grate and solid cover). Alternatively, a separate access vault may be provided as shown in Figure 3-22.
3. For vaults under roadways, the removable panel must be located outside the travel lanes. Alternatively, multiple standard locking manhole covers may be provided. Ladders and hand-holds need only be provided at the outlet pipe and inlet pipe, and as needed to meet OSHA confined space requirements. Vaults providing manhole access at 12-foot spacing need not provide corner ventilation pipes as specified in Item 10 below.
4. All access openings, except those covered by removable panels, may have round, solid locking lids, or 3-foot square, locking diamond plate covers.

5. Vaults with widths 10 feet or less must have removable lids.
6. The maximum depth from finished grade to the vault invert should be 20 feet.
7. Internal structural walls of large vaults should be provided with openings sufficient for maintenance access between cells. The openings should be sized and situated to allow access to the maintenance “v” in the vault floor.
8. The minimum internal height should be 7 feet from the highest point of the vault floor (not sump), and the minimum width should be 4 feet. However, concrete vaults may be a minimum 3 feet in height and width if used as a tank with access manholes at each end, and if the width is no larger than the height. Also the minimum internal height requirement may not be needed for any areas covered by removable panels.
9. Vaults must comply with the OSHA confined space requirements, which includes clearly marking entrances to confined space areas. This may be accomplished by hanging a removable sign in the access riser(s), just under the access lid.
10. Ventilation pipes (minimum 12-inch diameter or equivalent) should be provided in all four corners of vaults to allow for artificial ventilation prior to entry of maintenance personnel into the vault. Alternatively removable panels over the entire vault may be provided.

**Access Roads.** Access shall be designed and constructed as specified for detention ponds in Section 3.3.1.

**Setbacks.** For Setback Requirements See Section 3.3.1.

**Maintenance.** Provisions to facilitate maintenance operations must be built into the project when it is installed. Maintenance must be a basic consideration in design and in determination of first cost. See Table 3.7 for specific maintenance requirements.

## ***Methods of Analysis***

### **Detention Volume and Outflow**

The volume and outflow design for detention vaults must be in accordance with Minimum Requirement #7 in Volume I and the hydrologic analysis and design methods in Chapter 1. Restrictor and orifice design are given in Section 3.3.4.

#### **3.3.4 Control Structures**

*Control structures* are catch basins or manholes with a restrictor device for controlling outflow from a facility to meet the desired performance. Riser type restrictor devices (“tees” or “FROP-Ts”) also provide some incidental oil/water separation to temporarily detain oil or other floatable pollutants in runoff due to accidental spill or illegal dumping.

The restrictor device usually consists of two or more orifices and/or a weir section sized to meet performance requirements.

Standard control structure details are shown in Figure 3-23 through Figure 3-25.

## **Design Criteria**

### **Multiple Orifice Restrictor**

In most cases, control structures need only two orifices: one at the bottom and one near the top of the riser, although additional orifices may best utilize detention storage volume. Several orifices may be located at the same elevation if necessary to meet performance requirements.

1. Minimum orifice diameter is 0.5 inches. Note: In some instances, a 0.5-inch bottom orifice will be too large to meet target release rates, even with minimal head. In these cases, the live storage depth need not be reduced to less than 3 feet in an attempt to meet the performance standards. Also, under such circumstances, flow-throttling devices may be a feasible option. These devices will throttle flows while maintaining a plug-resistant opening.
2. Orifices may be constructed on a tee section as shown in Figure 3-23 or on a baffle as shown in Figure 3-24.
3. In some cases, performance requirements may require the top orifice/elbow to be located too high on the riser to be physically constructed (e.g., a 13-inch diameter orifice positioned 0.5 feet from the top of the riser). In these cases, a notch weir in the riser pipe may be used to meet performance requirements (see Figure 3-27).
5. Consideration shall be given to the backwater effect of water surface elevations in the conveyance system. High tailwater elevations may affect performance of the restrictor system and reduce live storage volumes. Backwater effects shall also be analyzed for areas that are influenced by tides.

### **Riser and Weir Restrictor**

1. Properly designed weirs may be used as flow restrictors (see Figure 3-25 and Figure 3-27 through Figure 3-29). However, they must be designed to provide for primary overflow of the developed 100-year peak flow discharging to the detention facility.
2. The combined orifice and riser (or weir) overflow may be used to meet performance requirements; however, the design must still provide for primary overflow of the developed 100-year peak flow assuming all orifices are plugged. Figure 3-30 can be used to calculate the head in feet above a riser of given diameter and flow.

**Access.** The following guidelines for access may be used.

1. An access road to the control structure is needed for inspection and maintenance, and must be designed and constructed as specified for detention ponds in Section 3.3.1.
2. Manhole and catch basin lids for control structures must be locking, and rim elevations must match proposed finish grade.

3. Manholes and catch-basins must meet the OSHA confined space requirements, which include clearly marking entrances to confined space areas. This may be accomplished by hanging a removable sign in the access riser, just under the access lid.

**Information Plate.** A brass or stainless steel plate shall be permanently attached inside each control structure with the following information engraved on the plate:

- Name and file number of project
- Name and company of (1) developer, (2) engineer, and (3) contractor
- Date constructed
- Date of manual used for design
- Outflow performance criteria
- Release mechanism size, type, and invert elevation
- List of stage, discharge, and volume at one-foot increments
- Elevation of overflow
- Recommended frequency of maintenance.

**Maintenance.** Control structures and catch basins have a history of maintenance-related problems. A typical problem is that sediment builds up inside the structure which blocks or restricts flow to the inlet. To prevent this problem these structures should be routinely cleaned out at least twice per year. Regular inspections of control structures should be conducted to detect the need for non-routine cleanout, especially if construction or land-disturbing activities are occurring in the contributing drainage area.

Table 3.8 provides maintenance recommendations for control structures and catch basins.

### **Methods of Analysis**

This section presents the methods and equations for design of **control structure restrictor devices**. Included are details for the design of orifices, rectangular sharp-crested weirs, v-notch weirs, sutro weirs, and overflow risers.

**Orifices.** Flow-through orifice plates in the standard tee section or turn-down elbow may be approximated by the general equation:

$$Q = C A \sqrt{2gh} \quad \text{(equation 4)}$$

where

- Q = flow (cfs)
- C = coefficient of discharge (0.62 for plate orifice)
- A = area of orifice (ft<sup>2</sup>)
- h = hydraulic head (ft)
- g = gravity (32.2 ft/sec<sup>2</sup>)

Figure 3-26 illustrates this simplified application of the orifice equation.

The diameter of the orifice is calculated from the flow. The orifice equation is often useful when expressed as the orifice diameter in inches:

$$d = \sqrt{\frac{36.88Q}{\sqrt{h}}} \quad (\text{equation 5})$$

where  $d$  = orifice diameter (inches)  
 $Q$  = flow (cfs)  
 $h$  = hydraulic head (ft)

**Rectangular Sharp-Crested Weir.** The rectangular sharp-crested weir design shown in Figure 3-27 may be analyzed using standard weir equations for the fully contracted condition.

$$Q = C(L - 0.2H)H^{3/2} \quad (\text{equation 6})$$

where  $Q$  = flow (cfs)  
 $C = 3.27 + 0.40 H/P$  (ft)  
 $H, P$  are as shown above  
 $L$  = length (ft) of the portion of the riser circumference as necessary not to exceed 50 percent of the circumference  
 $D$  = inside riser diameter (ft)

*Note that this equation accounts for side contractions by subtracting 0.1H from L for each side of the notch weir.*

### V-Notch Sharp - Crested Weir

V-notch weirs as shown in Figure 3-28 may be analyzed using standard equations for the fully contracted condition.

**Proportional or Sutro Weir.** Sutro weirs are designed so that the discharge is proportional to the total head. This design may be useful in some cases to meet performance requirements.

The sutro weir consists of a rectangular section joined to a curved portion that provides proportionality for all heads above the line A-B (see Figure 3-29). The weir may be symmetrical or non-symmetrical.

For this type of weir, the curved portion is defined by the following equation (calculated in radians):

$$\frac{x}{b} = 1 - \frac{2}{\pi} \text{Tan}^{-1} \sqrt{\frac{Z}{a}} \quad (\text{equation 7})$$

where  $a, b, x$  and  $Z$  are as shown in Figure 3-22. The head-discharge relationship is:

$$Q = C_d b \sqrt{2ga \left( h_1 - \frac{a}{3} \right)} \quad (\text{equation 8})$$

Values of  $C_d$  for both symmetrical and non-symmetrical sutro weirs are summarized in Table 3.9.



*Note: When  $b > 1.50$  or  $a > 0.30$ , use  $C_d=0.6$ .*

**Riser Overflow.** The nomograph in Figure 3-30 can be used to determine the head (in feet) above a riser of given diameter and for a given flow (usually the 100-year peak flow for developed conditions).

### **3.3.5 Other Detention Options**

This section presents other design options for detaining flows to meet flow control facility requirements.

**Use of Parking Lots for Additional Detention.** Private parking lots may be used to provide additional detention volume for runoff events greater than the 2-year runoff event provided all of the following are met:

1. The depth of water detained does not exceed 0.5 feet (6 inches) at any location in the parking lot for runoff events up to and including the 100-year event.
2. The gradient of the parking lot area subject to ponding is 1 percent or greater.
3. The emergency overflow path is identified and noted on the engineering plan. The overflow must not create a significant adverse impact to downhill properties or drainage system.
4. Fire lanes used for emergency equipment are free of ponding water for all runoff events up to and including the 100-year event.

#### **Use of Roofs for Detention**

Detention ponding on roofs of structures may be used to meet flow control requirements provided all of the following are met:

1. The roof support structure is analyzed by a structural engineer to address the weight of ponded water and meets the requirements of the applicable building code.
2. The roof area subject to ponding is sufficiently waterproofed to achieve a minimum service life of 30 years.
3. The minimum pitch of the roof area subject to ponding is 1/4-inch per foot.
4. An overflow system is included in the design to safely convey the 100-year peak flow from the roof
5. A mechanism is included in the design to allow the ponding area to be drained for maintenance purposes or in the event the restrictor device is plugged.

<b>Table 3.1 -- Recommended Infiltration Rates based on USDA Soil Textural Classification.</b>			
	<b>*Short-Term Infiltration Rate (in./hr)</b>	<b>Correction Factor, CF</b>	<b>Estimated Long-Term (Design) Infiltration Rate (in./hr)</b>
Clean sandy gravels and gravelly sands (i.e., 90% of the total soil sample is retained in the #10 sieve)	20	2	10
Sand	8	4	2
Loamy Sand	2	4	0.5
Sandy Loam	1	4	0.25
Loam	0.5	4	0.13

\*From WEF/ASCE, 1998.

<b>Table 3.2 -- Alternative Recommended Infiltration Rates based on ASTM Gradation Testing.</b>	
<b>D<sub>10</sub> Size from ASTM D422 Soil Gradation Test (mm)</b>	<b>Estimated Long-Term (Design) Infiltration Rate (in./hr)</b>
≥ 0.4	9
0.3	6.5
0.2	3.5
0.1	2.0
0.05	0.8

<b>Table 3.3 -- Correction Factors to be Used With In-Situ Infiltration Measurements to Estimate Long-Term Design Infiltration Rates.</b>	
<b>Issue</b>	<b>Partial Correction Factor</b>
Site variability and number of locations tested	CF <sub>v</sub> = 1.5 to 6
Degree of long-term maintenance to prevent siltation and bio-buildup	CF <sub>m</sub> = 2 to 6
Degree of influent control to prevent siltation and bio-buildup	CF <sub>i</sub> = 2 to 6

$$CF = CF_v + CF_m + CF_i$$

<b>Table 3.4</b>	
<b>Small Trees and Shrubs with Fibrous Roots</b>	
<b>Small Trees / High Shrubs</b>	<b>Low Shrubs</b>
*Red twig dogwood ( <i>Cornus stolonifera</i> )	*Snowberry ( <i>Symphoricarpos albus</i> )
*Serviceberry ( <i>Amelanchier alnifolia</i> )	*Salmonberry ( <i>Rubus spectabilis</i> )
*Filbert ( <i>Corylus cornuta</i> , others)	Rosa rugosa (avoid spreading varieties)
Highbush cranberry ( <i>Vaccinium opulus</i> )	Rock rose ( <i>Cistus spp.</i> )
Blueberry ( <i>Vaccinium spp.</i> )	Ceanothus spp. choose hardier varieties)
Fruit trees on dwarf rootstock	New Zealand flax ( <i>Phormium tenax</i> )
Rhododendron (native and ornamental varieties)	Ornamental grasses (e.g., <i>Miscanthus</i> , <i>Pennisetum</i> )
*Native species	

<b>Table 3.5</b>	
<b>Stormwater Tract "Low Grow" Seed Mix</b>	
<b>Seed Name</b>	<b>Percentage of Mix</b>
Dwarf tall fescue	40%
Dwarf perennial rye "Barclay"*	30%
Red fescue	25%
Colonial bentgrass	5%

\* If wildflowers are used and sowing is done before Labor Day, the amount of dwarf perennial rye can be reduced proportionately to the amount of wildflower seed used.

**Table 3.6  
Specific Maintenance Requirements for Detention Ponds**

<b>Maintenance Component</b>	<b>Defect</b>	<b>Conditions When Maintenance Is Needed</b>	<b>Results Expected When Maintenance Is Performed</b>
<b>General</b>	Trash & Debris	Any trash and debris which exceed 5 cubic feet per 1,000 square feet (this is about equal to the amount of trash it would take to fill up one standard size garbage can). In general, there should be no visual evidence of dumping. If less than threshold all trash and debris will be removed as part of next scheduled maintenance.	Trash and debris cleared from site.
	Poisonous Vegetation and noxious weeds	Any poisonous or nuisance vegetation which may constitute a hazard to maintenance personnel or the public. Any evidence of noxious weeds as defined by State or local regulations. (Apply requirements of adopted Integrated Pest Management (IPM) policies for the use of herbicides).	No danger of poisonous vegetation where maintenance personnel or the public might normally be. (Coordinate with local health department) Complete eradication of noxious weeds may not be possible. Compliance with State or local eradication policies required
	Contaminants and Pollution	Any evidence of oil, gasoline, contaminants or other pollutants (Coordinate removal/cleanup with local water quality response agency).	No contaminants or pollutants present.
	Rodent Holes	Any evidence of rodent holes if facility is acting as a dam or berm, or any evidence of water piping through dam or berm via rodent holes.	Rodents destroyed and dam or berm repaired. (Coordinate with local health department and Ecology Dam Safety Office if pone exceeds 10 acre feet)
	Beaver Dams	Dam results in change or function of the facility.	Facility is returned to design function. (Coordinate trapping of beavers and removal of dams with appropriate permitting agencies)
	Insects	When insects such as wasps and hornets interfere with maintenance activities.	Insects destroyed or removed from site. Apply insecticides in compliance with adopted IPM policies
	Tree Growth and Hazard Trees	Tree growth does not allow maintenance access or interferes with maintenance activity (i.e., slope mowing, silt removal, vactoring, or equipment movements). If trees are not interfering with access or maintenance, do not remove If dead, diseased, or dying trees are identified (Use a certified Arborist to determine health of tree or removal requirements)	Trees do not hinder maintenance activities. Harvested trees should be recycled into mulch or other beneficial uses (e.g., alders for firewood). Remove hazard trees

**Table 3.6  
Specific Maintenance Requirements for Detention Ponds**

<b>Maintenance Component</b>	<b>Defect</b>	<b>Conditions When Maintenance Is Needed</b>	<b>Results Expected When Maintenance Is Performed</b>
<b>Side Slopes of Pond</b>	Erosion	Eroded damage over 2 inches deep where cause of damage is still present or where there is potential for continued erosion. Any erosion observed on a compacted berm embankment.	Slopes should be stabilized using appropriate erosion control measure(s); e.g., rock reinforcement, planting of grass, compaction. If erosion is occurring on compacted berms a licensed civil engineer should be consulted to resolve source of erosion.
<b>Storage Area</b>	Sediment	Accumulated sediment that exceeds 10% of the designed pond depth unless otherwise specified or affects inletting or outletting condition of the facility.	Sediment cleaned out to designed pond shape and depth; pond reseeded if necessary to control erosion.
	Liner (If Applicable)	Liner is visible and has more than three 1/4-inch holes in it.	Liner repaired or replaced. Liner is fully covered.
<b>Pond Berms (Dikes)</b>	Settlements	Any part of berm which has settled 4 inches lower than the design elevation. If settlement is apparent measure berm to determine amount of settlement. Settling can be an indication of more severe problems with the berm or outlet works. A licensed civil engineer should be consulted to determine the source of the settlement.	Dike is built back to the design elevation.
	Piping	Discernable water flow through pond berm. Ongoing erosion with potential for erosion to continue. (Recommend a Geotechnical engineer be called in to inspect and evaluate condition and recommend repair of condition.	Piping eliminated. Erosion potential resolved.
<b>Emergency Overflow/Spillway and Berms over 4 feet in height.</b>	Tree Growth	Tree growth on emergency spillways create blockage problems and may cause failure of the berm due to uncontrolled overtopping. Tree growth on berms over 4 feet in height may lead to piping through the berm which could lead to failure of the berm.	Trees should be removed. If root system is small (base less than 4 inches) the root system may be left in place. Otherwise the roots should be removed and the berm restored. A licensed civil engineer should be consulted for proper berm/spillway restoration.
	Piping	Discernable water flow through pond berm. Ongoing erosion with potential for erosion to continue. (Recommend a Geotechnical engineer be called in to inspect and evaluate condition and recommend repair of condition.	Piping eliminated. Erosion potential resolved.
<b>Emergency Overflow/Spillway</b>	Emergency Overflow/Spillway	Only one layer of rock exists above native soil in area five square feet or larger, or any exposure of native soil at the top of out flow path of spillway. (Rip-rap on inside slopes need not be replaced.)	Rocks and pad depth are restored to design standards.
	Erosion	See "Side slopes of Pond"	

**Table 3.7  
Specific Maintenance Requirements for Detention Vaults/Tanks**

<b>Maintenance Component</b>	<b>Defect</b>	<b>Conditions When Maintenance is Needed</b>	<b>Results Expected When Maintenance is Performed</b>
<b>Storage Area</b>	Plugged Air Vents	One-half of the cross section of a vent is blocked at any point or the vent is damaged.	Vents open and functioning.
	Debris and Sediment	Accumulated sediment depth exceeds 10% of the diameter of the storage area for 1/2 length of storage vault or any point depth exceeds 15% of diameter.  (Example: 72-inch storage tank would require cleaning when sediment reaches depth of 7 inches for more than 1/2 length of tank.)	All sediment and debris removed from storage area.
	Joints Between Tank/Pipe Section	Any openings or voids allowing material to be transported into facility.  (Will require engineering analysis to determine structural stability).	All joint between tank/pipe sections are sealed.
	Tank Pipe Bent Out of Shape	Any part of tank/pipe is bent out of shape more than 10% of its design shape. (Review required by engineer to determine structural stability).	Tank/pipe repaired or replaced to design.
	Vault Structure Includes Cracks in Wall, Bottom, Damage to Frame and/or Top Slab	Cracks wider than 1/2-inch and any evidence of soil particles entering the structure through the cracks, or maintenance/inspection personnel determines that the vault is not structurally sound.  Cracks wider than 1/2-inch at the joint of any inlet/outlet pipe or any evidence of soil particles entering the vault through the walls.	Vault replaced or repaired to design specifications and is structurally sound.  No cracks more than 1/4-inch wide at the joint of the inlet/outlet pipe.
<b>Manhole</b>	Cover Not in Place	Cover is missing or only partially in place. Any open manhole requires maintenance.	Manhole is closed.
	Locking Mechanism Not Working	Mechanism cannot be opened by one maintenance person with proper tools. Bolts into frame have less than 1/2 inch of thread (may not apply to self-locking lids).	Mechanism opens with proper tools.
	Cover Difficult to Remove	One maintenance person cannot remove lid after applying normal lifting pressure. Intent is to keep cover from sealing off access to maintenance.	Cover can be removed and reinstalled by one maintenance person.
	Ladder Rungs Unsafe	Ladder is unsafe due to missing rungs, misalignment, not securely attached to structure wall, rust, or cracks.	Ladder meets design standards. Allows maintenance person safe access.

**Table 3.8  
Maintenance of Control Structures and Catch Basins**

<b>Maintenance Component</b>	<b>Defect</b>	<b>Condition When Maintenance is Needed</b>	<b>Results Expected When Maintenance is Performed</b>
<b>General</b>	Trash and Debris (Includes Sediment)	Material exceeds 25% of sump depth or 1 foot below orifice plate.	Control structure orifice is not blocked. All trash and debris removed.
	Structural Damage	Structure is not securely attached to manhole wall.	Structure securely attached to wall and outlet pipe.
		Structure is not in upright position (allow up to 10% from plumb).	Structure in correct position.
		Connections to outlet pipe are not watertight and show signs of rust.	Connections to outlet pipe are water tight; structure repaired or replaced and works as designed.
		Any holes--other than designed holes--in the structure.	Structure has no holes other than designed holes.
<b>Cleanout Gate</b>	Damaged or Missing	Cleanout gate is not watertight or is missing.	Gate is watertight and works as designed.
		Gate cannot be moved up and down by one maintenance person.	Gate moves up and down easily and is watertight.
		Chain/rod leading to gate is missing or damaged.	Chain is in place and works as designed.
		Gate is rusted over 50% of its surface area.	Gate is repaired or replaced to meet design standards.
<b>Orifice Plate</b>	Damaged or Missing	Control device is not working properly due to missing, out of place, or bent orifice plate.	Plate is in place and works as designed.
	Obstructions	Any trash, debris, sediment, or vegetation blocking the plate.	Plate is free of all obstructions and works as designed.
<b>Overflow Pipe</b>	Obstructions	Any trash or debris blocking (or having the potential of blocking) the overflow pipe.	Pipe is free of all obstructions and works as designed.
<b>Manhole</b>	See Table 3.4	See Table 3.4	See Table 3.4
<b>Catch Basin</b>	See "Catch Basins"	See "Catch Basins"	See "Catch Basins"
<b>CATCH BASINS</b>			
<b>General</b>	Trash & Debris	Trash or debris which is located immediately in front of the catch basin opening or is blocking inletting capacity of the basin by more than 10%.	No Trash or debris located immediately in front of catch basin or on grate opening.
		Trash or debris (in the basin) that exceeds 60 percent of the sump depth as measured from the bottom of basin to invert of the lowest pipe into or out of the basin, but in no case less than a minimum of six inches clearance from the debris surface to the invert of the lowest pipe.	No trash or debris in the catch basin.
	Sediment	Trash or debris in any inlet or outlet pipe blocking more than 1/3 of its height.	Inlet and outlet pipes free of trash or debris.
		Dead animals or vegetation that could generate odors that could cause complaints or dangerous gases (e.g., methane).	No dead animals or vegetation present within the catch basin.
		Sediment (in the basin) that exceeds 60 percent of the sump depth as measured from the bottom of basin to invert of the lowest pipe into or out of the basin, but in no case less than a minimum of 6 inches clearance from the sediment surface to the invert of the lowest pipe. Measured from the bottom of basin to invert of the lowest pipe into or out of the basin.	No sediment in the catch basin

**Table 3.8  
Maintenance of Control Structures and Catch Basins**

<b>Maintenance Component</b>	<b>Defect</b>	<b>Condition When Maintenance is Needed</b>	<b>Results Expected When Maintenance is Performed</b>
	Structure Damage to Frame and/or Top Slab	Top slab has holes larger than 2 square inches or cracks wider than 1/4 inch (Intent is to make sure no material is running into basin).	Top slab is free of holes and cracks.
		Frame not sitting flush on top slab, i.e., separation of more than 3/4 inch of the frame from the top slab. Frame not securely attached	Frame is sitting flush on the riser rings or top slab and firmly attached.
	Fractures or Cracks in Basin Walls/ Bottom	Maintenance person judges that structure is unsound.	Basin replaced or repaired to design standards.
		Grout fillet has separated or cracked wider than 1/2 inch and longer than 1 foot at the joint of any inlet/outlet pipe or any evidence of soil particles entering catch basin through cracks.	Pipe is regouted and secure at basin wall.
	Settlement/ Misalignment	If failure of basin has created a safety, function, or design problem.	Basin replaced or repaired to design standards.
	Vegetation	Vegetation growing across and blocking more than 10% of the basin opening.	No vegetation blocking opening to basin.
		Vegetation growing in inlet/outlet pipe joints that is more than six inches tall and less than six inches apart.	No vegetation or root growth present.
Contamination and Pollution	See "Detention Ponds"	No pollution present.	
<b>Catch Basin Cover</b>	Cover Not in Place	Cover is missing or only partially in place. Any open catch basin requires maintenance.	Catch basin cover is closed
	Locking Mechanism Not Working	Mechanism cannot be opened by one maintenance person with proper tools. Bolts into frame have less than 1/2 inch of thread.	Mechanism opens with proper tools.
	Cover Difficult to Remove	One maintenance person cannot remove lid after applying normal lifting pressure. (Intent is keep cover from sealing off access to maintenance.)	Cover can be removed by one maintenance person.
<b>Ladder</b>	Ladder Rungs Unsafe	Ladder is unsafe due to missing rungs, not securely attached to basin wall, misalignment, rust, cracks, or sharp edges.	Ladder meets design standards and allows maintenance person safe access.
<b>Metal Grates (If Applicable)</b>	Grate opening Unsafe	Grate with opening wider than 7/8 inch.	Grate opening meets design standards.
	Trash and Debris	Trash and debris that is blocking more than 20% of grate surface inletting capacity.	Grate free of trash and debris.
	Damaged or Missing.	Grate missing or broken member(s) of the grate.	Grate is in place and meets design standards.



**Table 3.9**  
**Values of  $C_d$  for Sutro Weirs**

<b><i>C<sub>d</sub> Values, Symmetrical</i></b>					
<b><i>b (ft)</i></b>					
<b>a (ft)</b>	<b>0.50</b>	<b>0.75</b>	<b>1.0</b>	<b>1.25</b>	<b>1.50</b>
0.02	0.608	0.613	0.617	0.6185	0.619
0.05	0.606	0.611	0.615	0.617	0.6175
0.10	0.603	0.608	0.612	0.6135	0.614
0.15	0.601	0.6055	0.610	0.6115	0.612
0.20	0.599	0.604	0.608	0.6095	0.610
0.25	0.598	0.6025	0.6065	0.608	0.6085
0.30	0.597	0.602	0.606	0.6075	0.608
<b><i>C<sub>d</sub> Values, Non-Symmetrical</i></b>					
<b><i>b (ft)</i></b>					
<b>a (ft)</b>	<b>0.50</b>	<b>0.75</b>	<b>1.0</b>	<b>1.25</b>	<b>1.50</b>
0.02	0.614	0.619	0.623	0.6245	0.625
0.05	0.612	0.617	0.621	0.623	0.6235
0.10	0.609	0.614	0.618	0.6195	0.620
0.15	0.607	0.6115	0.616	0.6175	0.618
0.20	0.605	0.610	0.614	0.6155	0.616
0.25	0.604	0.6085	0.6125	0.614	0.6145
0.30	0.603	0.608	0.612	0.6135	0.614

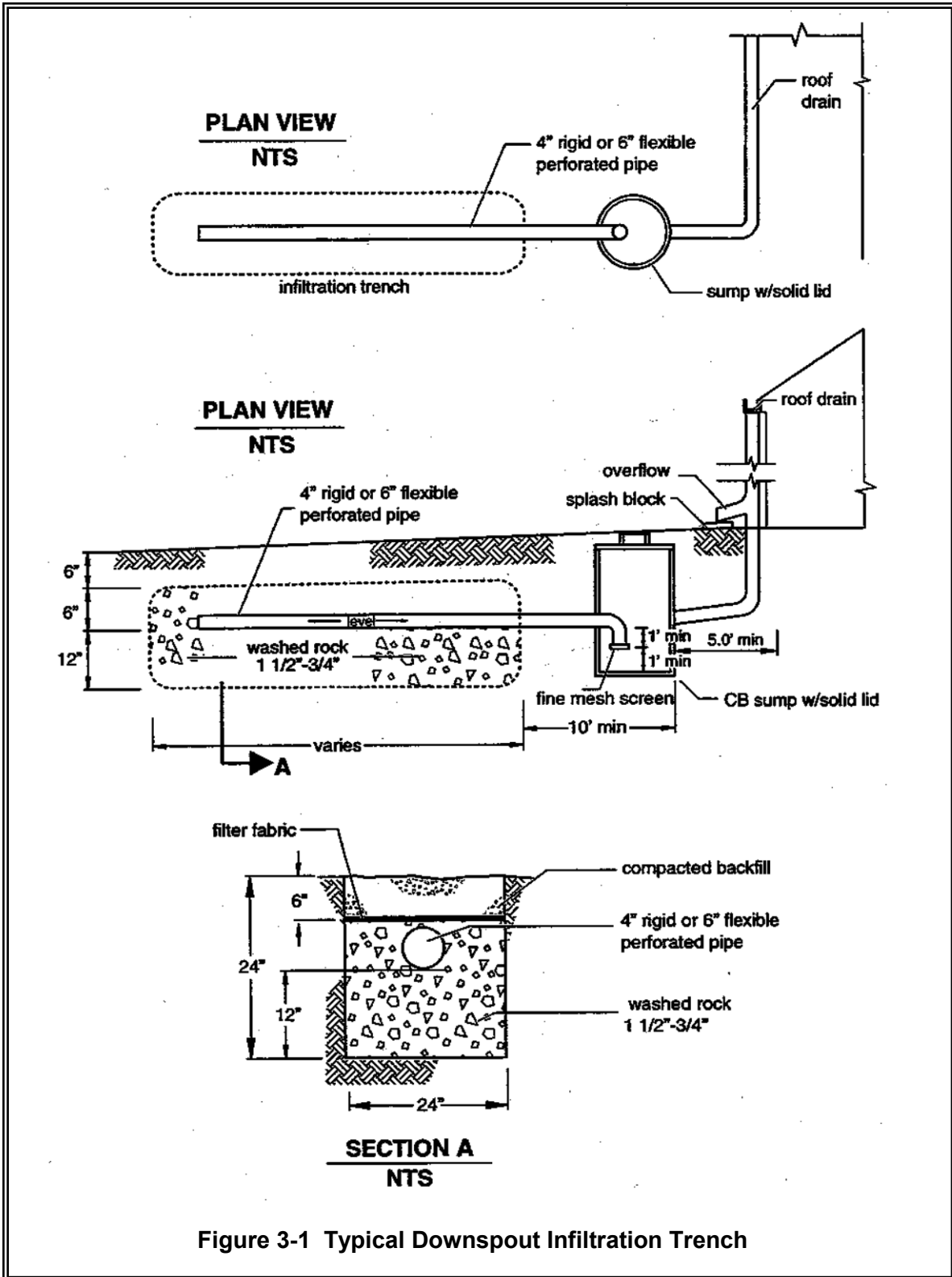
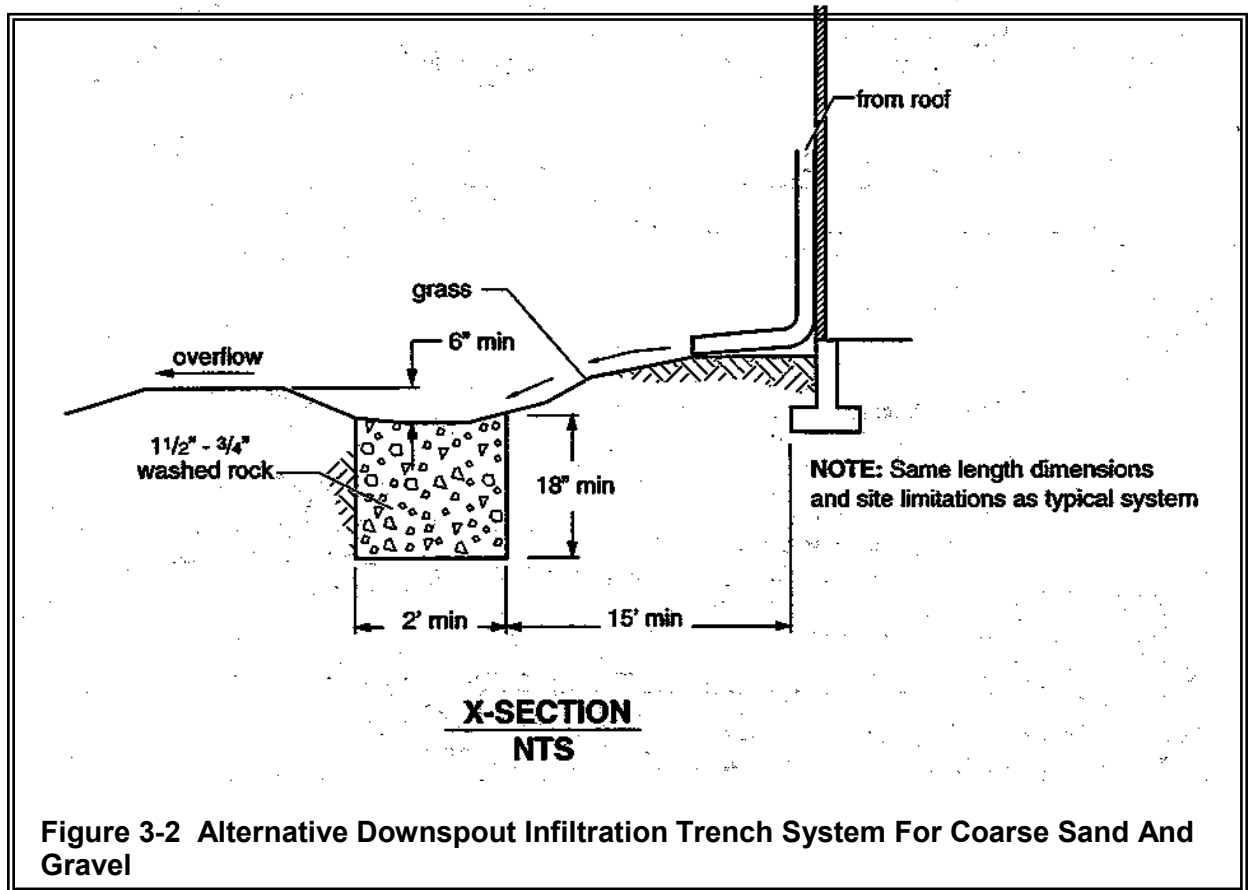


Figure 3-1 Typical Downspout Infiltration Trench

Source: King County



Source: King County

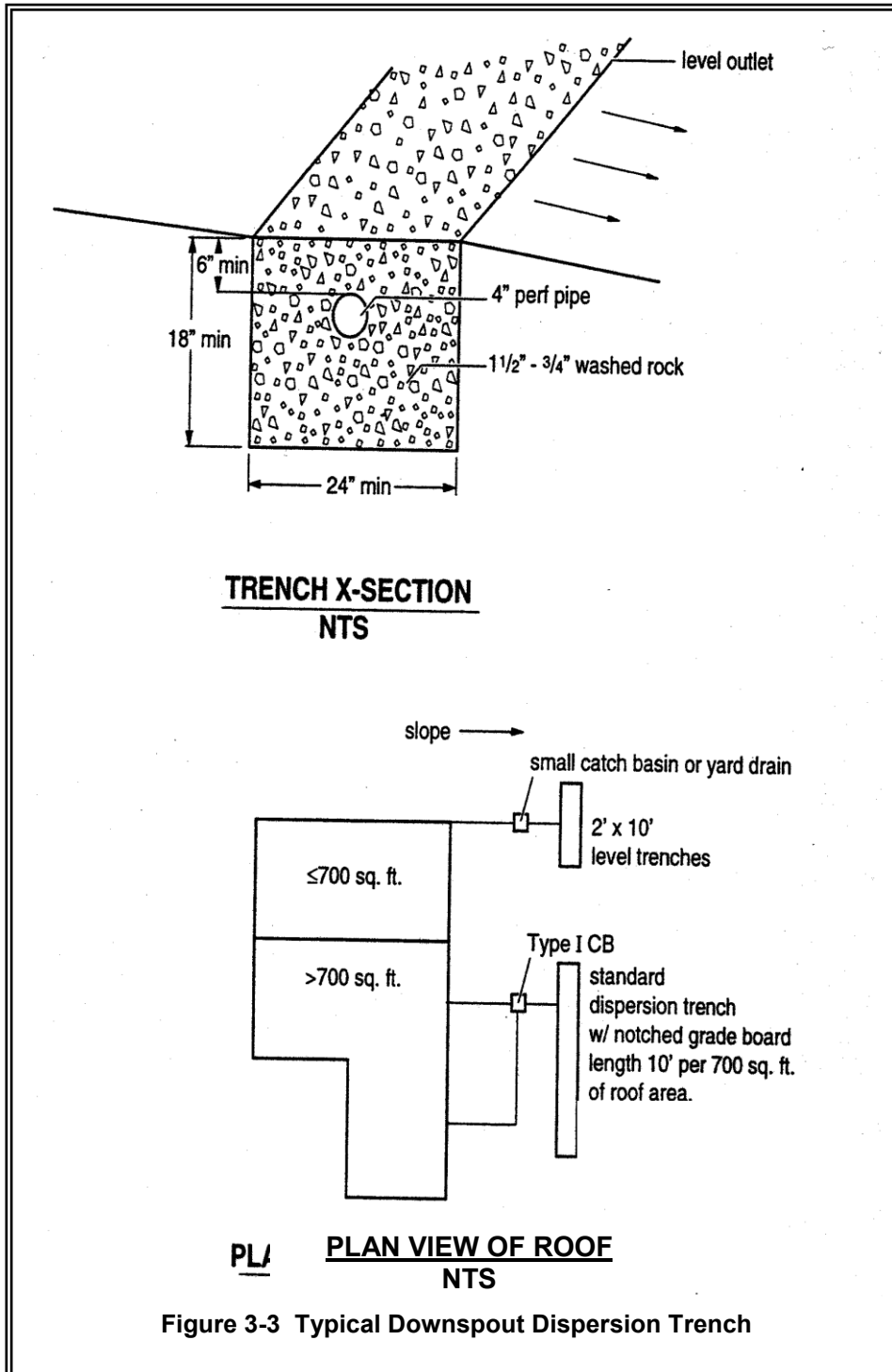


Figure 3-3 Typical Downspout Dispersion Trench

Source: King County

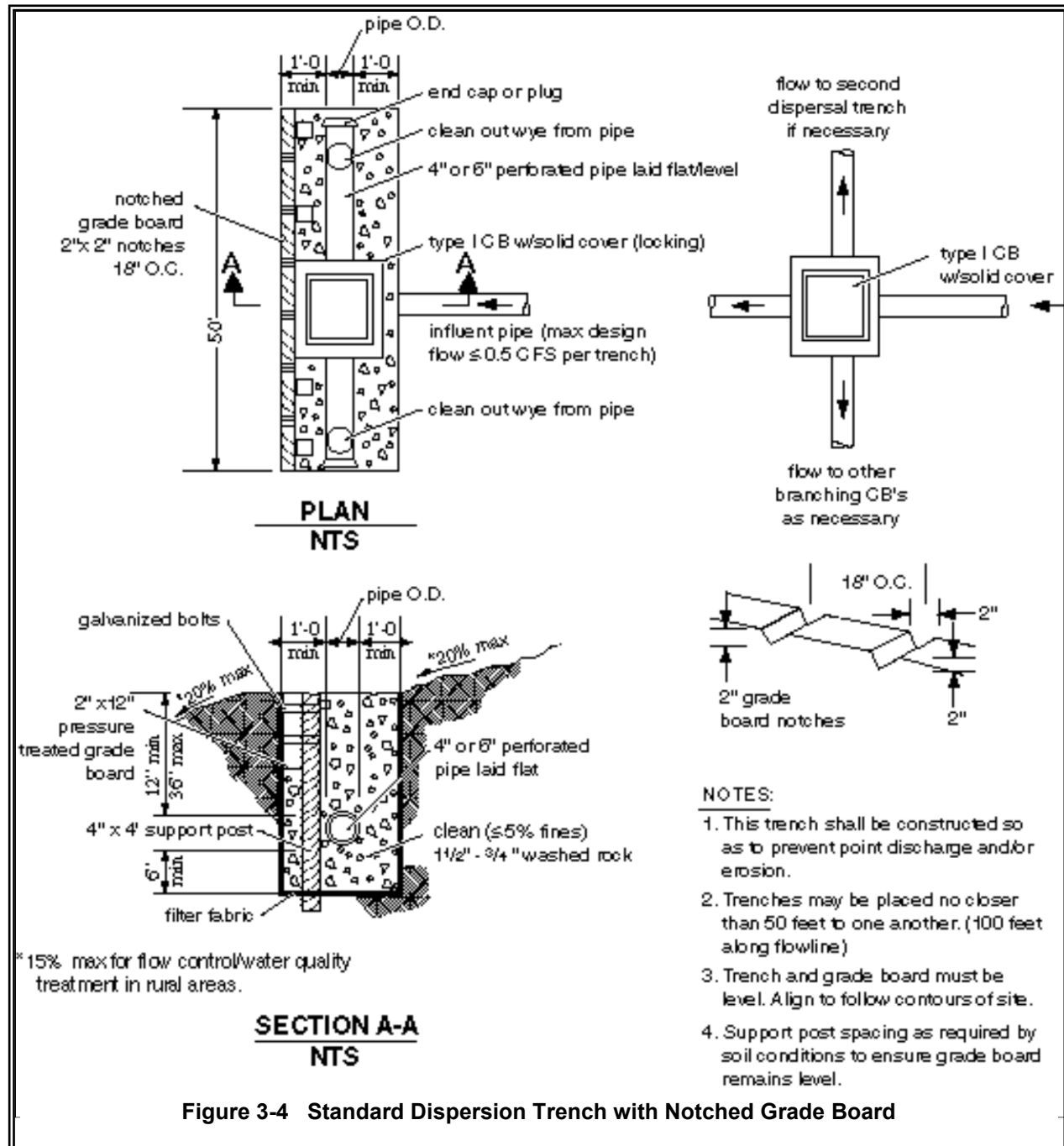
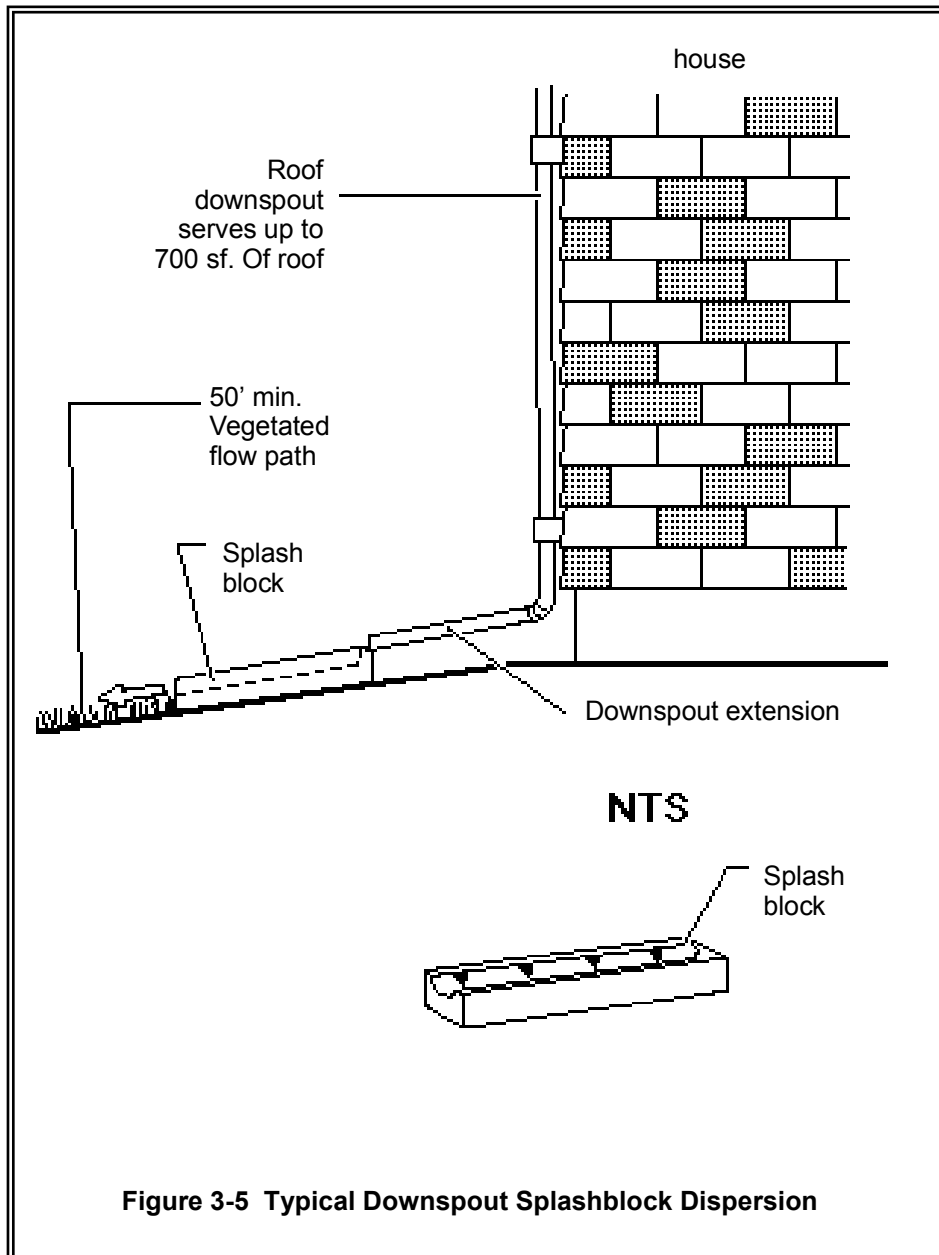
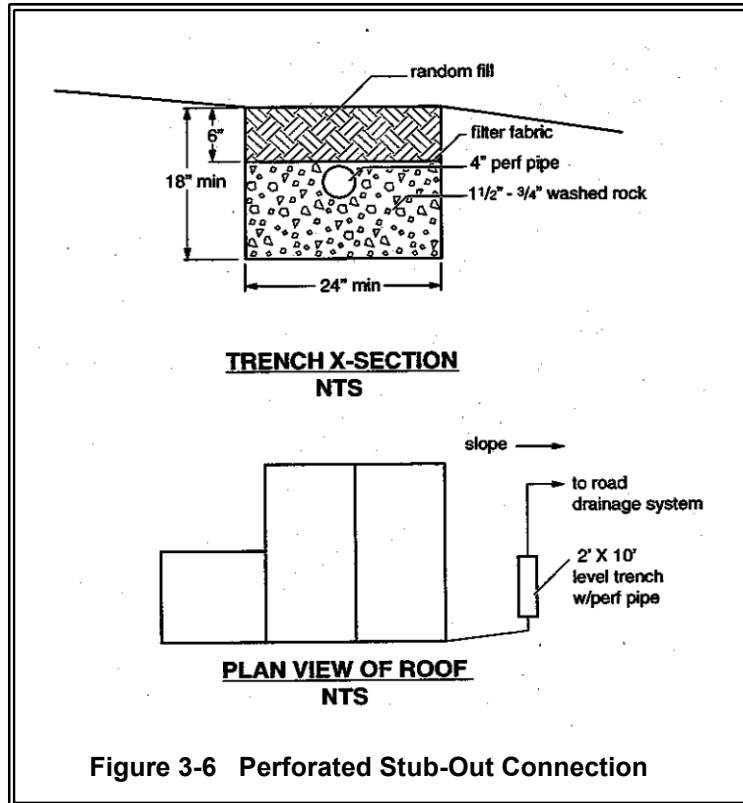
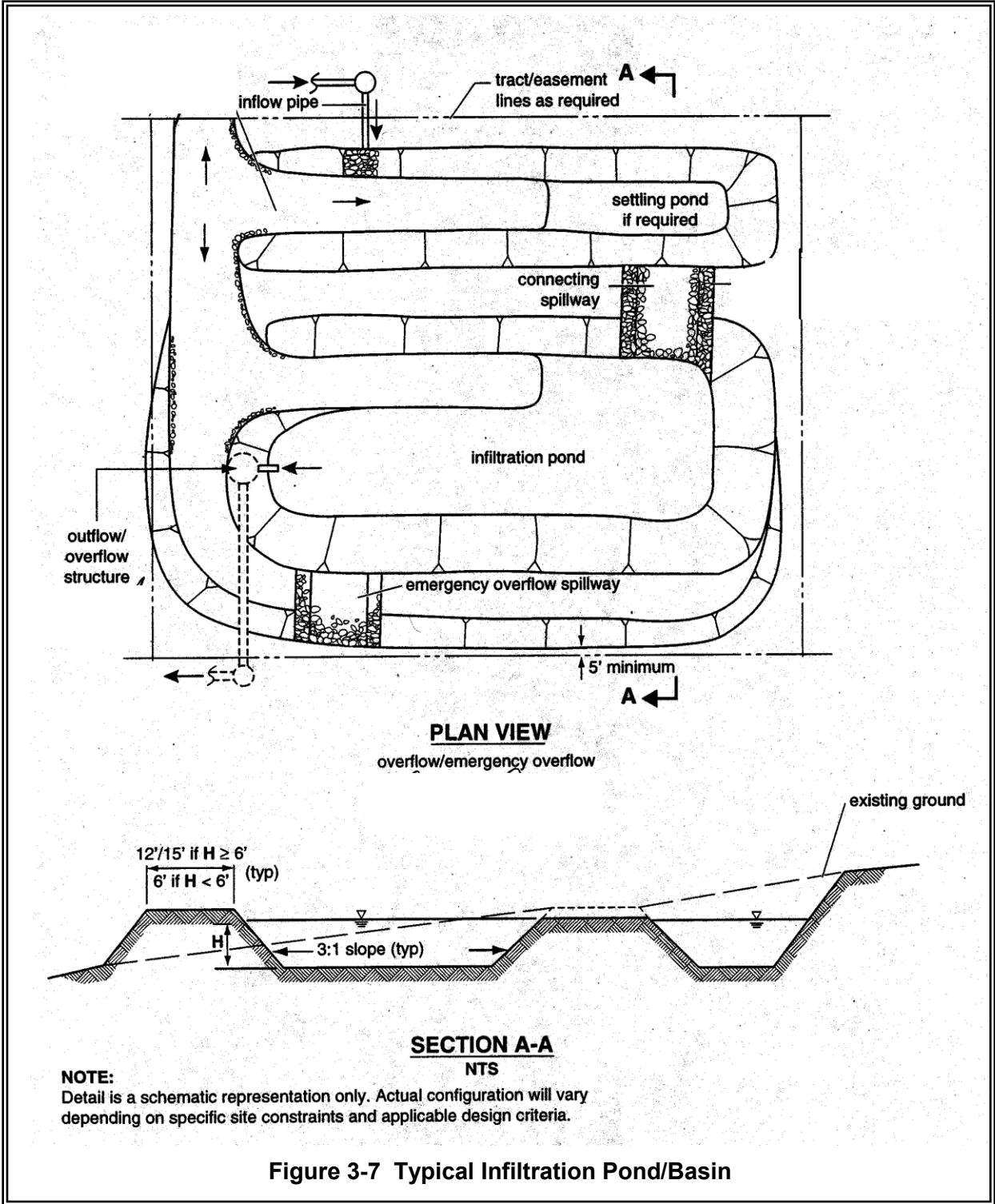


Figure 3-4 Standard Dispersion Trench with Notched Grade Board



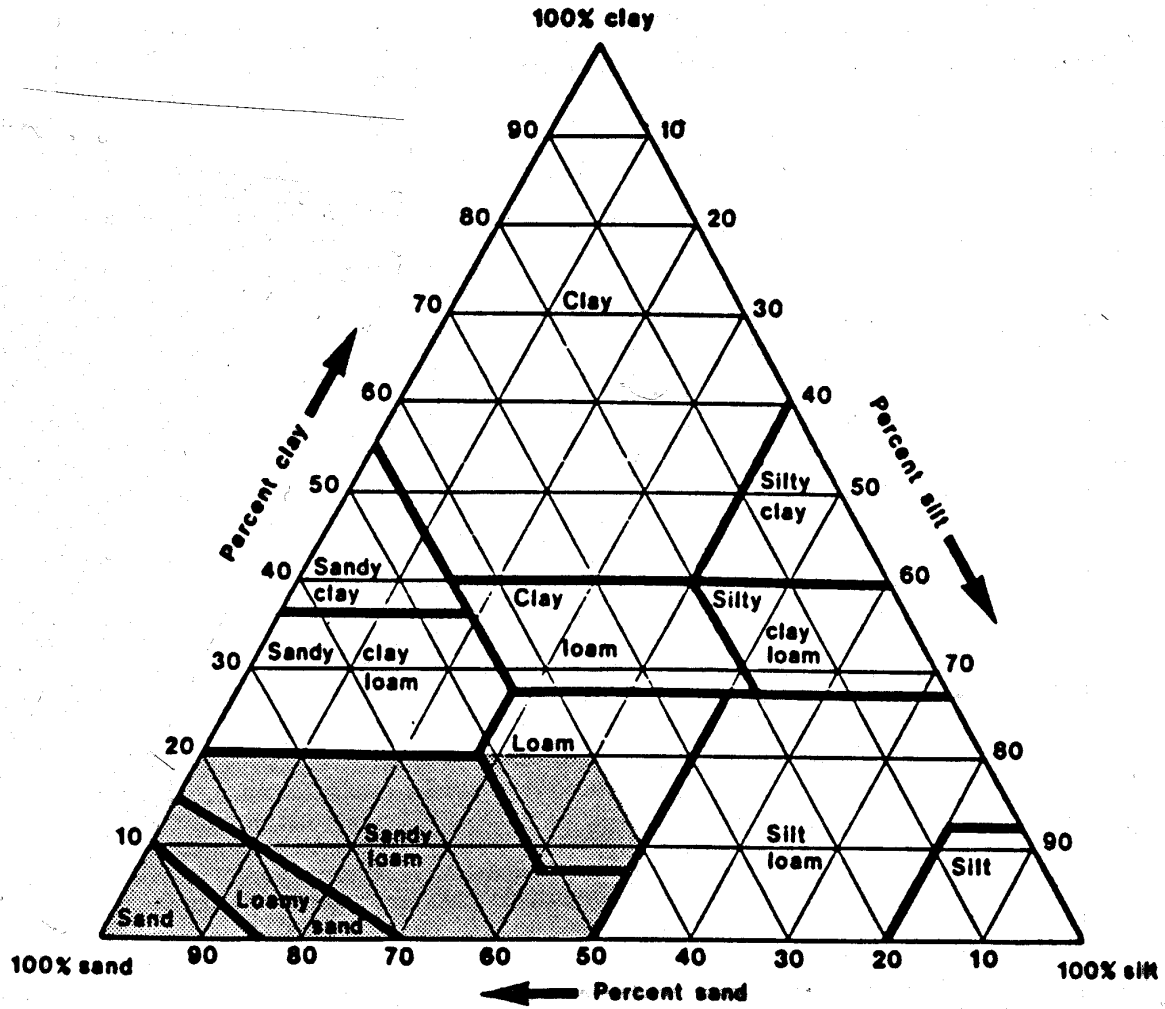


Source: King County





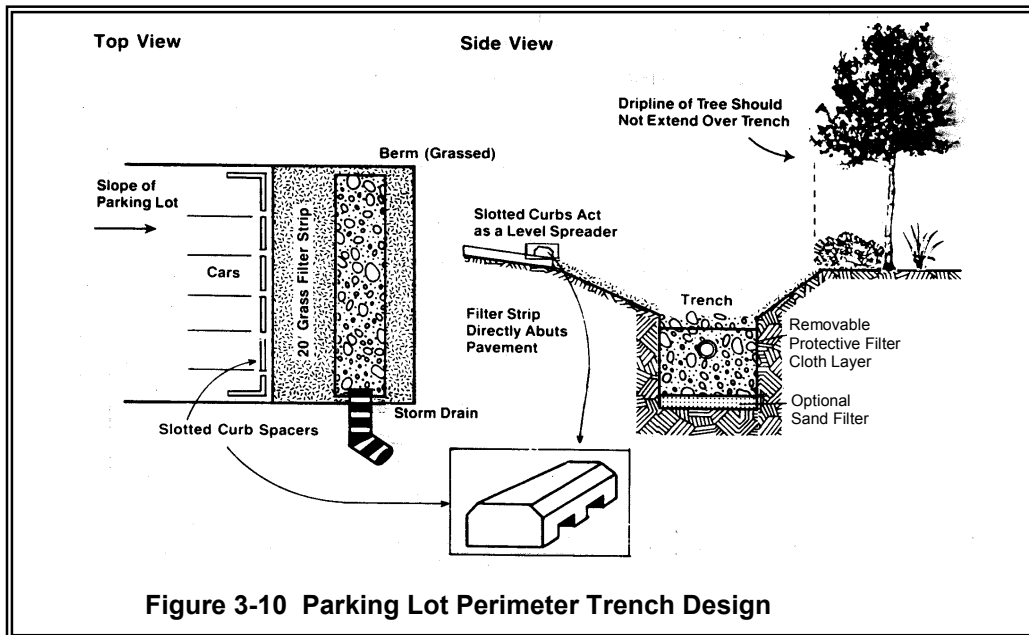
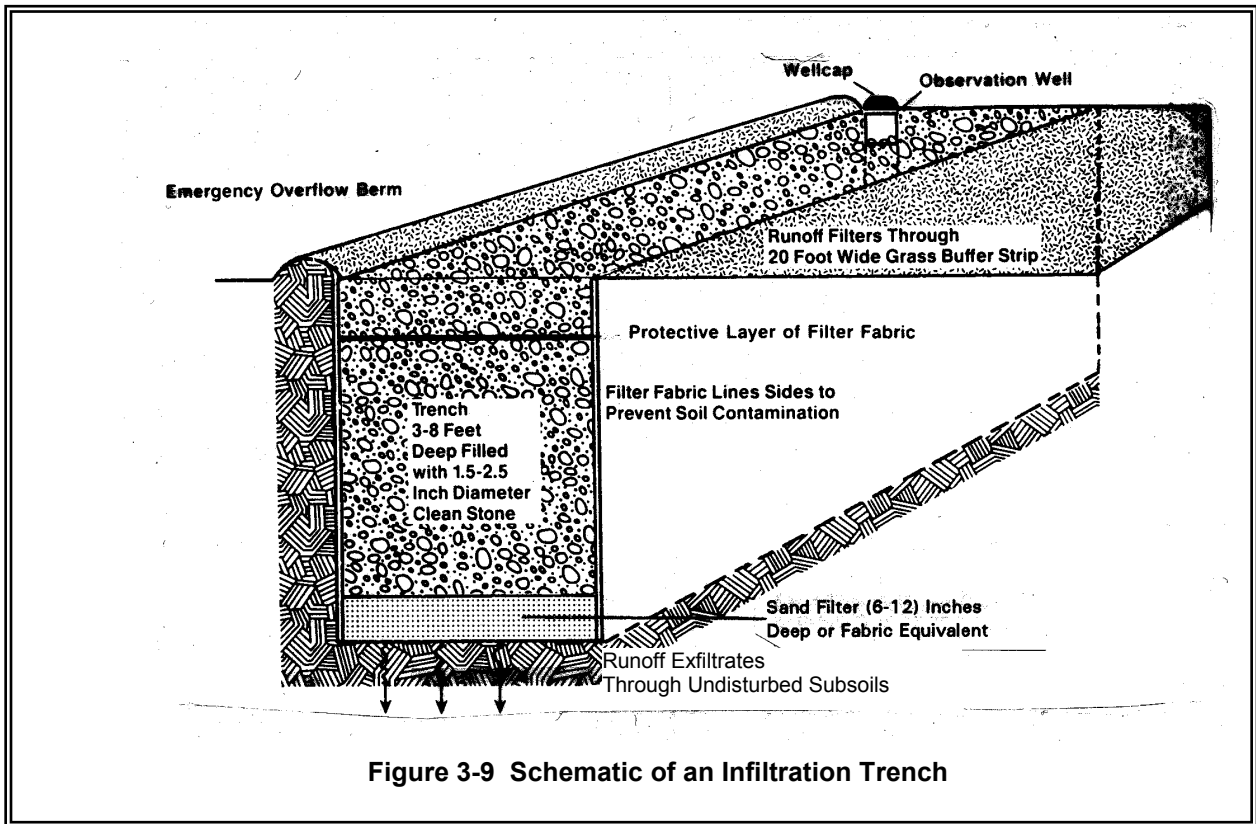
# Textural Triangle U.S.D.A.



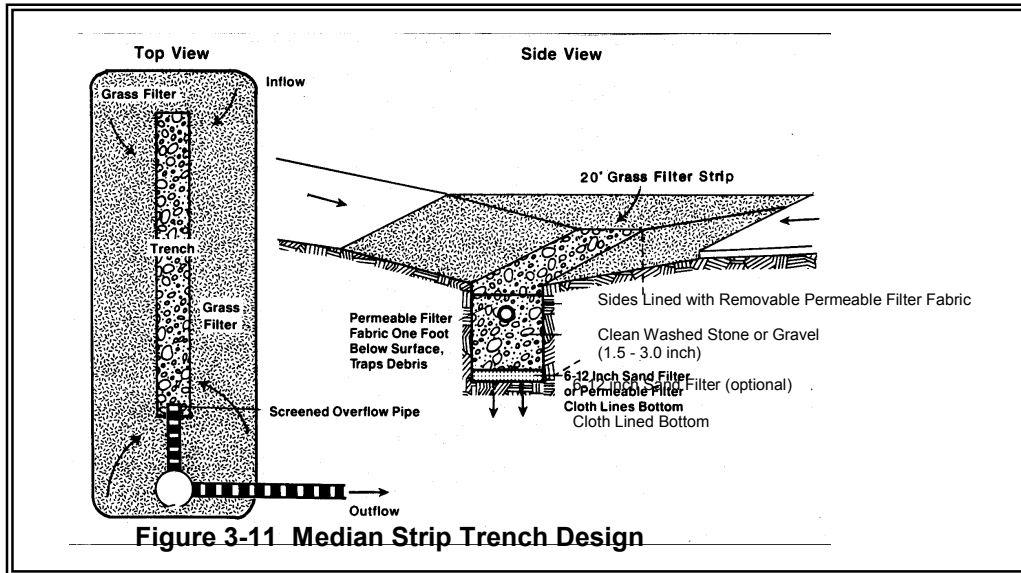
Shaded area is applicable for design of infiltration BMPs

Figure 3-8 USDA Textural Triangle

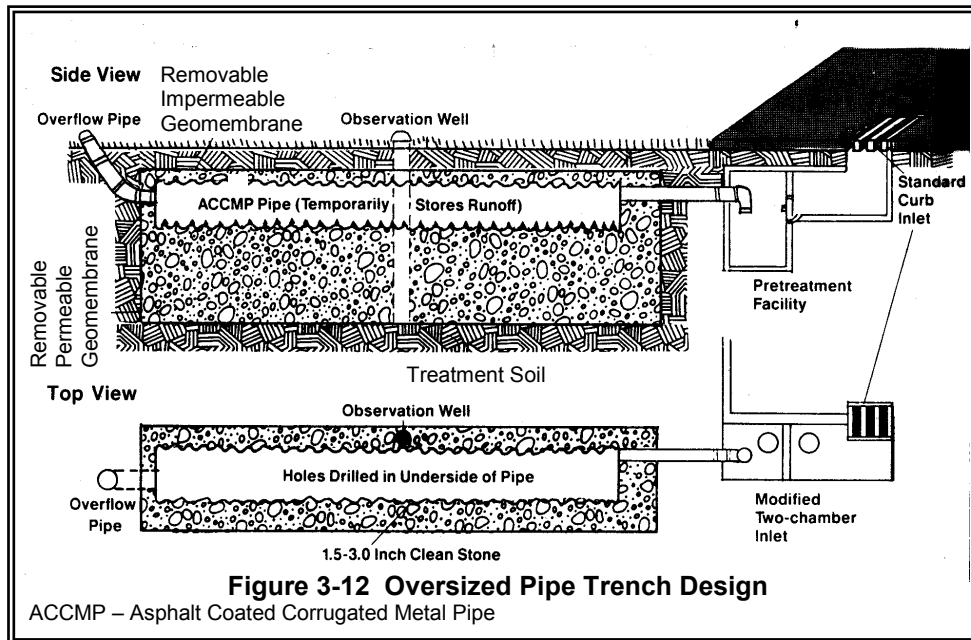
Source: U.S. Department of Agriculture



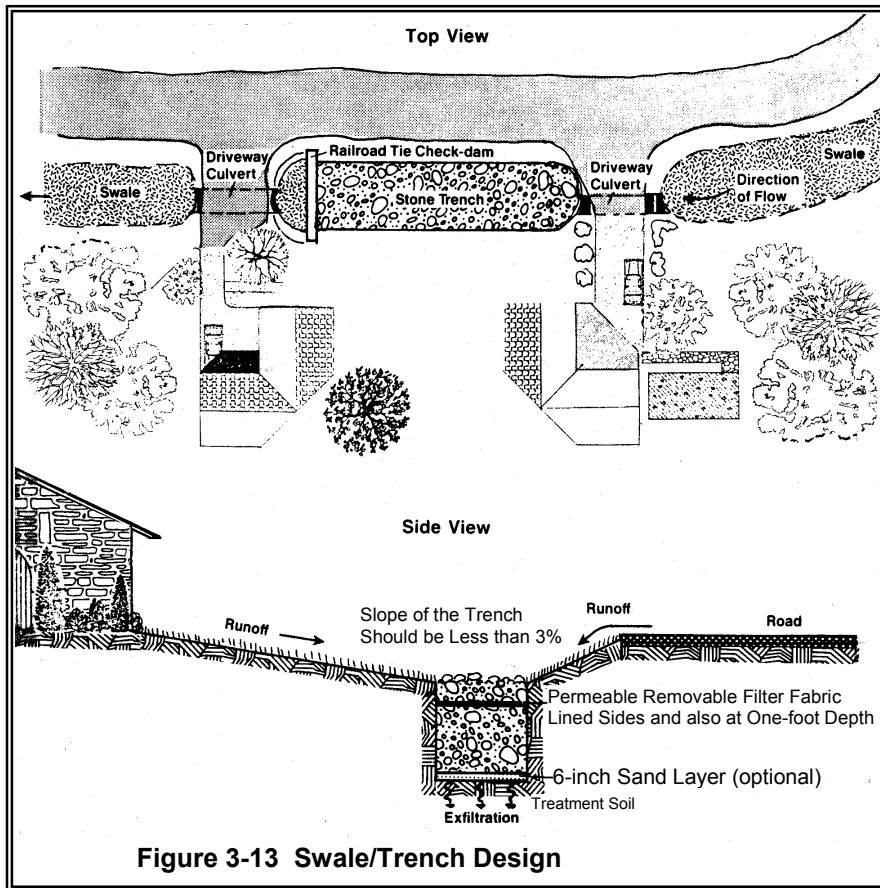
Source: Schueler (reproduced with Permission)



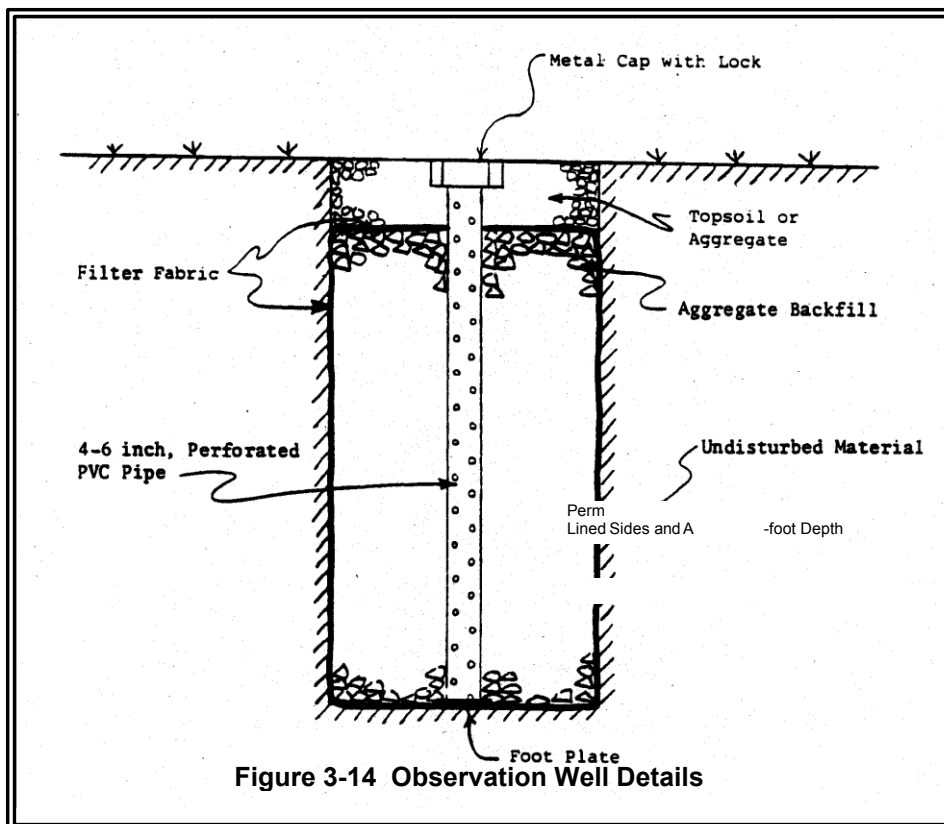
Source: Schueler (reproduced with permission)



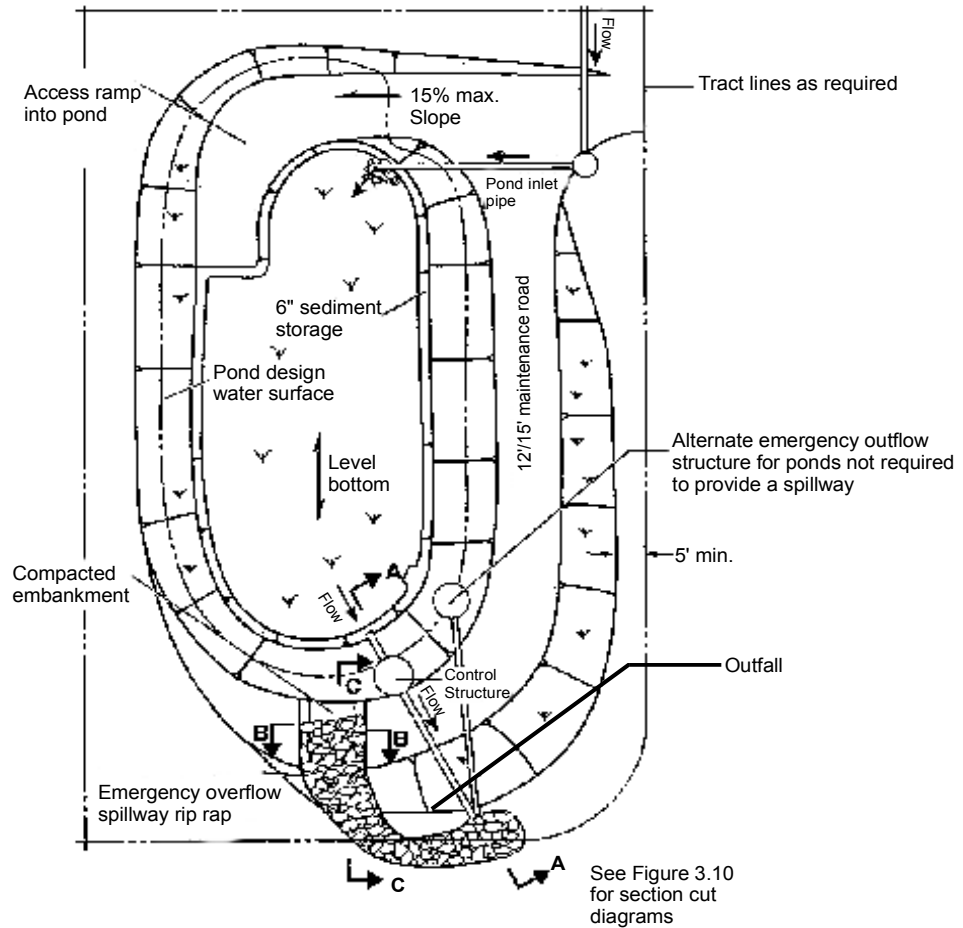
Source: Schueler (reproduced with permission)



Source: Schueler (reproduced with permission)



**Figure 3-15 Typical Detention Pond**



Note:  
This detail is a schematic representation only. Actual configuration will vary depending on specific site constraints and applicable design criteria.

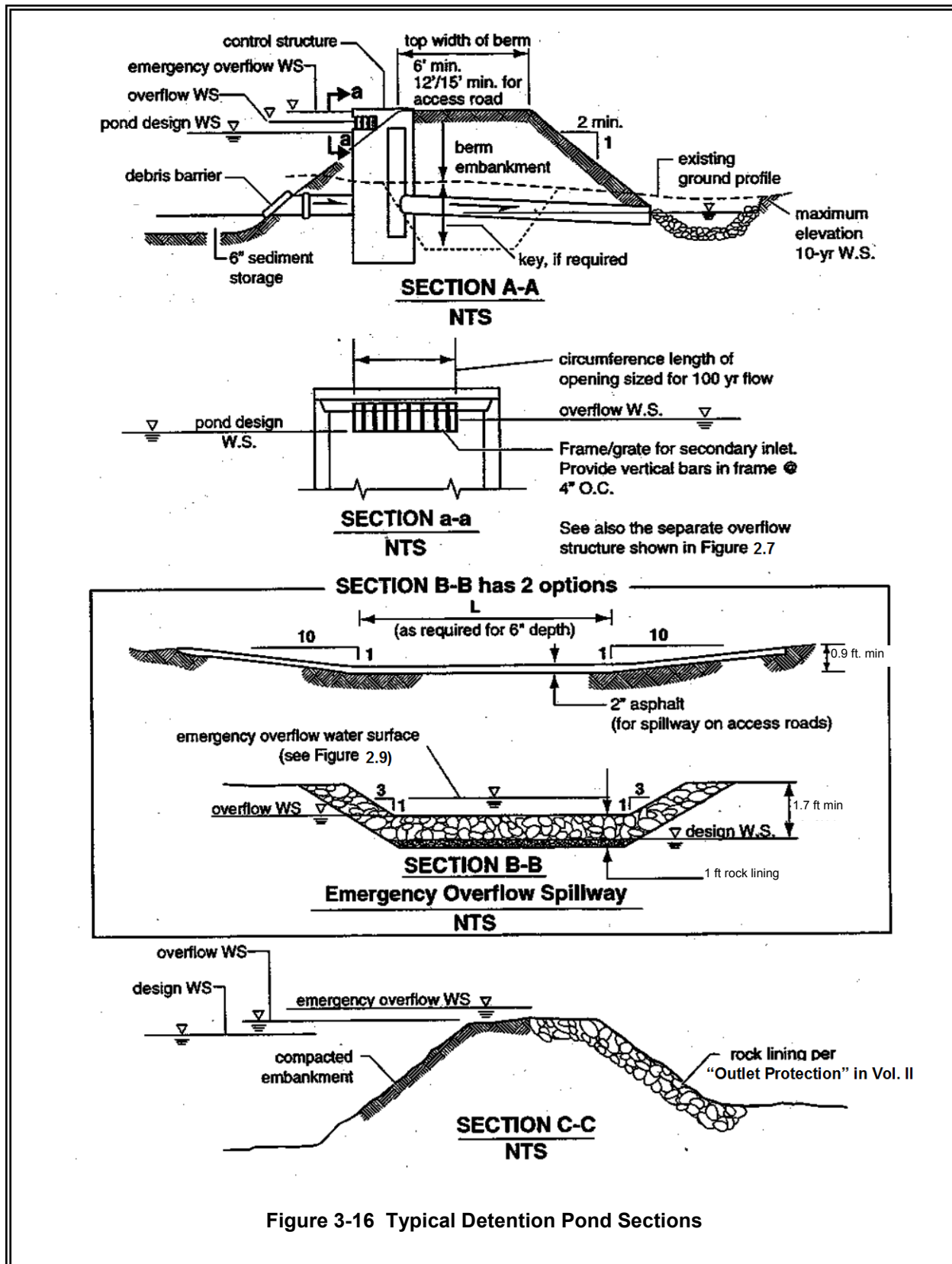


Figure 3-16 Typical Detention Pond Sections

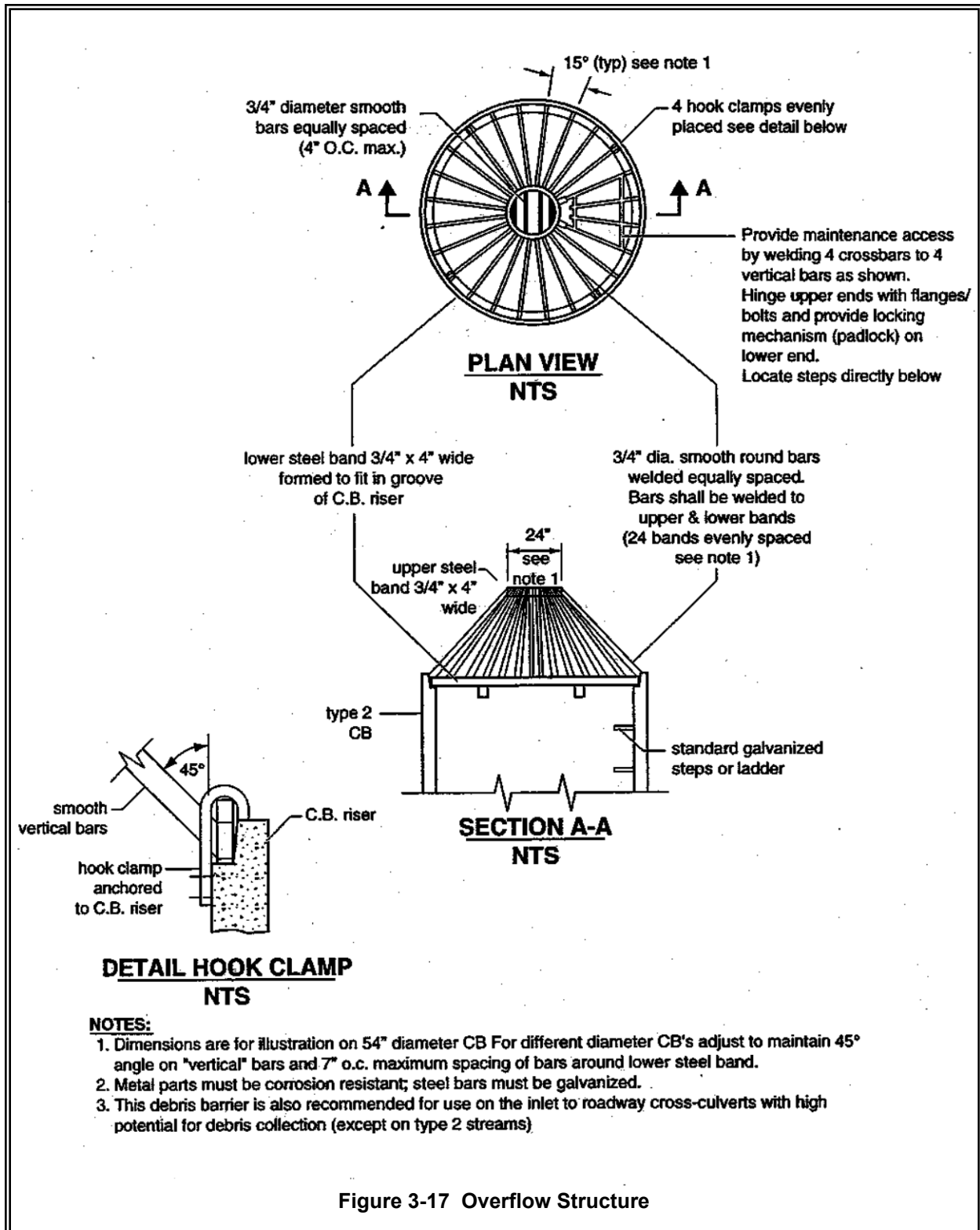
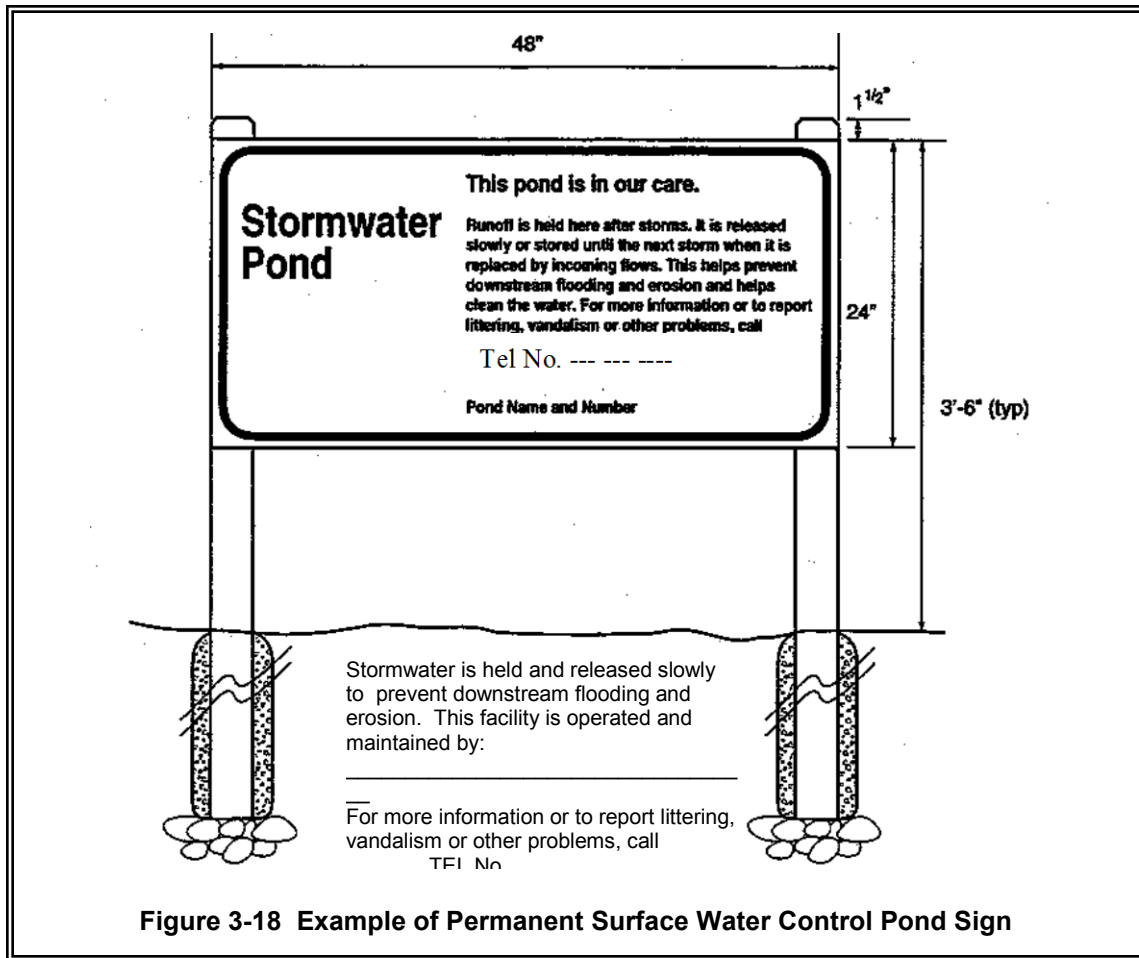


Figure 3-17 Overflow Structure

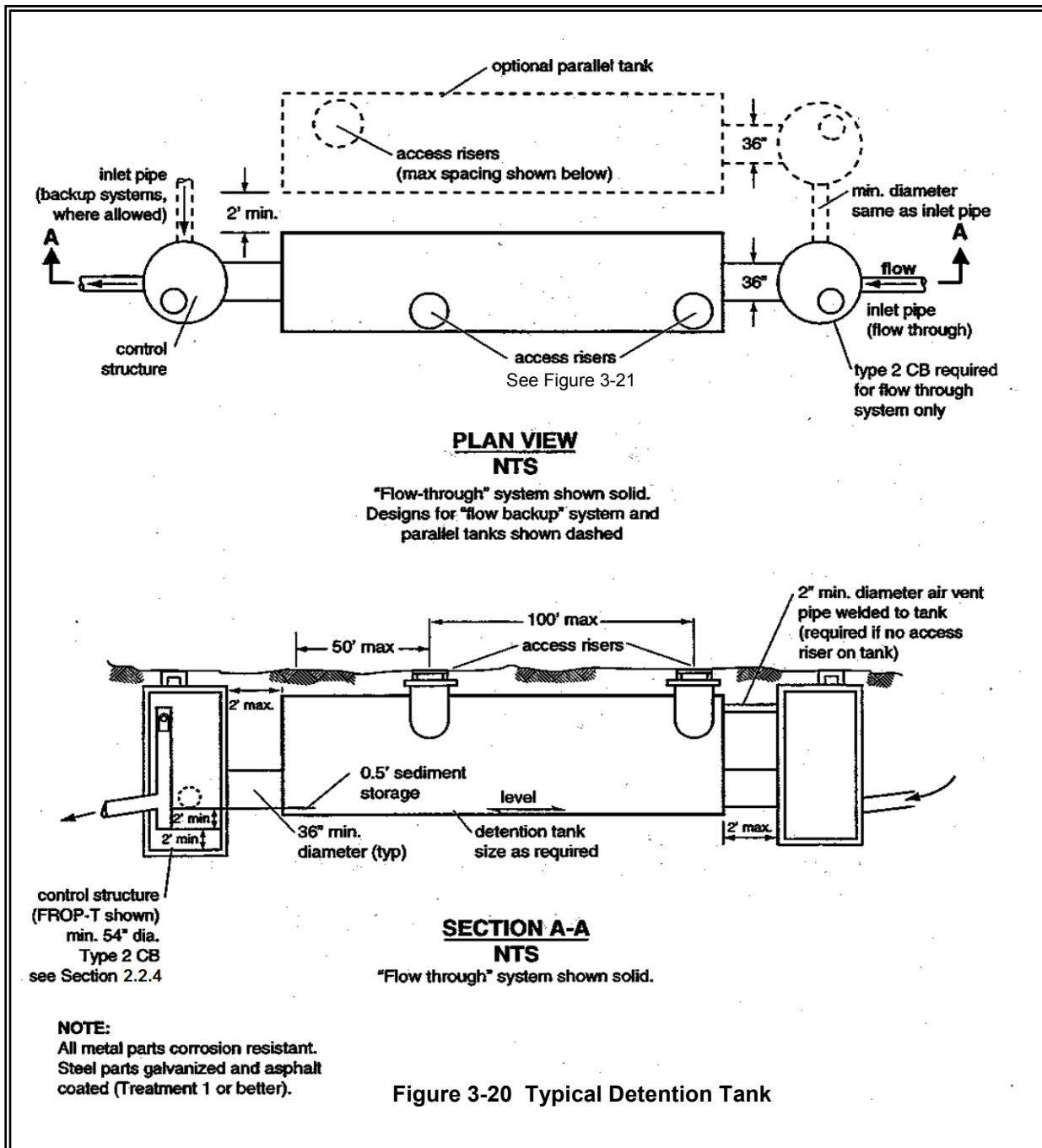
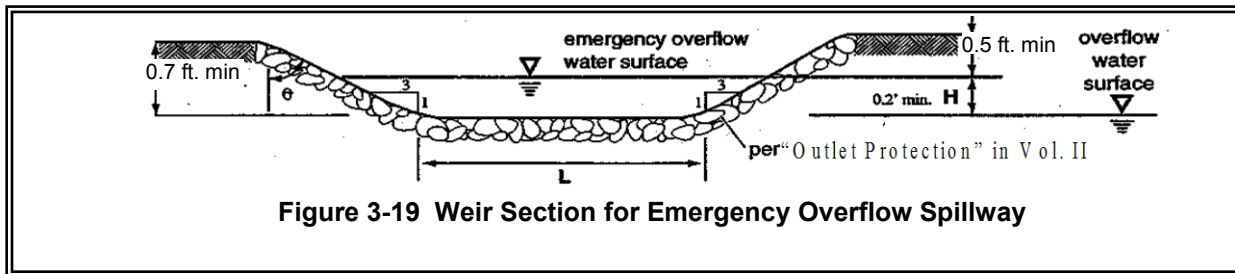


**Figure 3-18 Example of Permanent Surface Water Control Pond Sign**

**Sample Specifications:**

- Size: 48 inches by 24 inches
- Material: 0.125-gauge aluminum
- Face: Non-reflective vinyl or 3 coats outdoor enamel (sprayed).
- Lettering: Silk screen enamel where possible, or vinyl letters.
- Colors: Per City specifications where required.
- Type face: Helvetica condensed. Title: 3 inch; Sub-Title: 1½ inch; Text: 1 inch; Outer border: 1/8 inch border distance from edge: 1/4 inch; all text 1¼ inch from border.
- Posts: Pressure treated, beveled tops, 1½ inch higher than sign.
- Installation: Secure to chain link fence if available. Otherwise install on two 4"x4" posts, pressure treated, mounted atop gravel bed, installed in 30-inch concrete filled post holes (8-inch minimum diameter). Top of sign no higher than 42 inches from ground surface.
- Placement: Face sign in direction of primary visual or physical access. Do not block any access road. Do not place within 6 feet of structural facilities (e.g. manholes, spillways, pipe inlets).
- Special Notes: This facility is lined to protect groundwater (if a liner that restricts infiltration of stormwater exists).





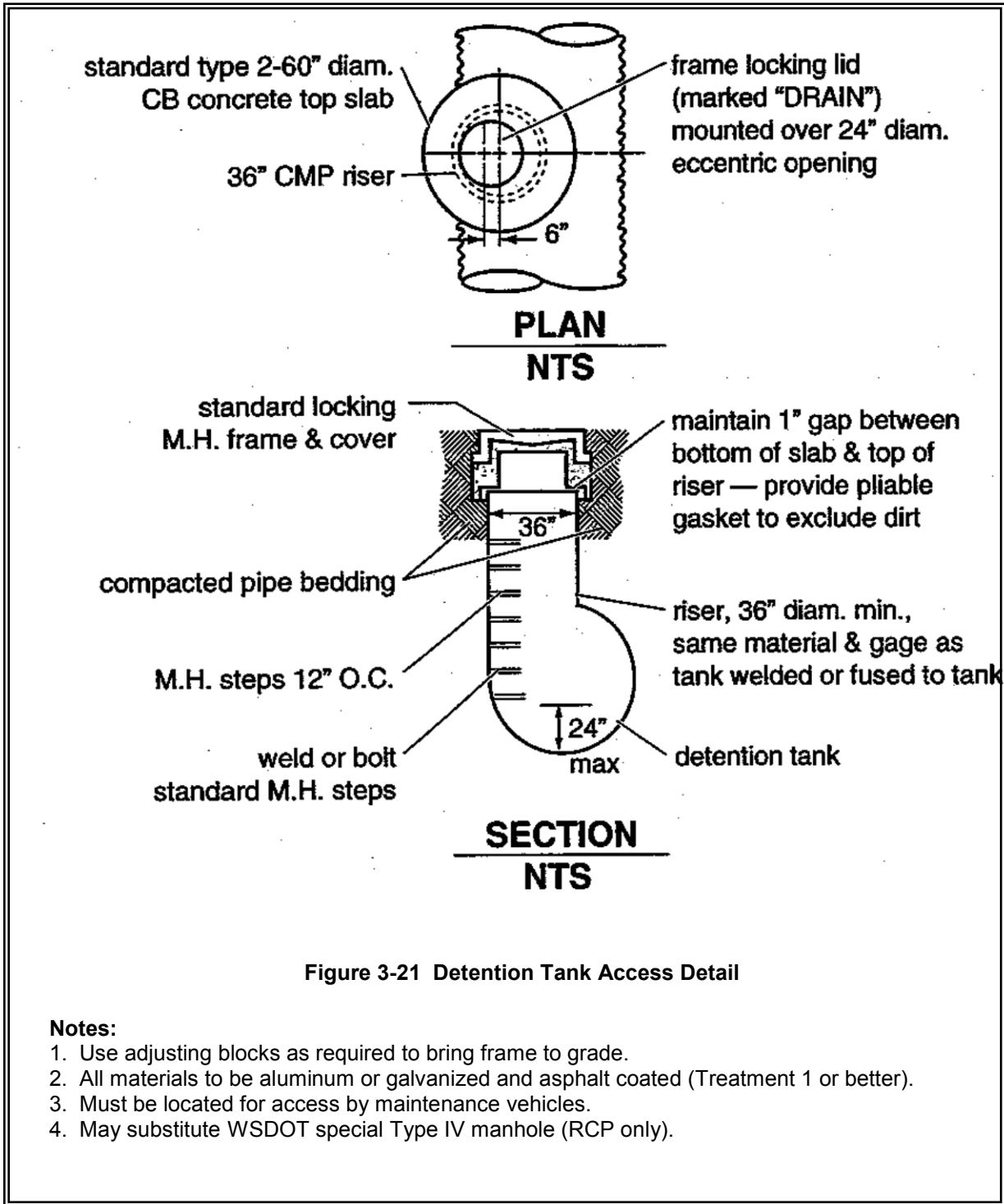


Figure 3-21 Detention Tank Access Detail

**Notes:**

1. Use adjusting blocks as required to bring frame to grade.
2. All materials to be aluminum or galvanized and asphalt coated (Treatment 1 or better).
3. Must be located for access by maintenance vehicles.
4. May substitute WSDOT special Type IV manhole (RCP only).

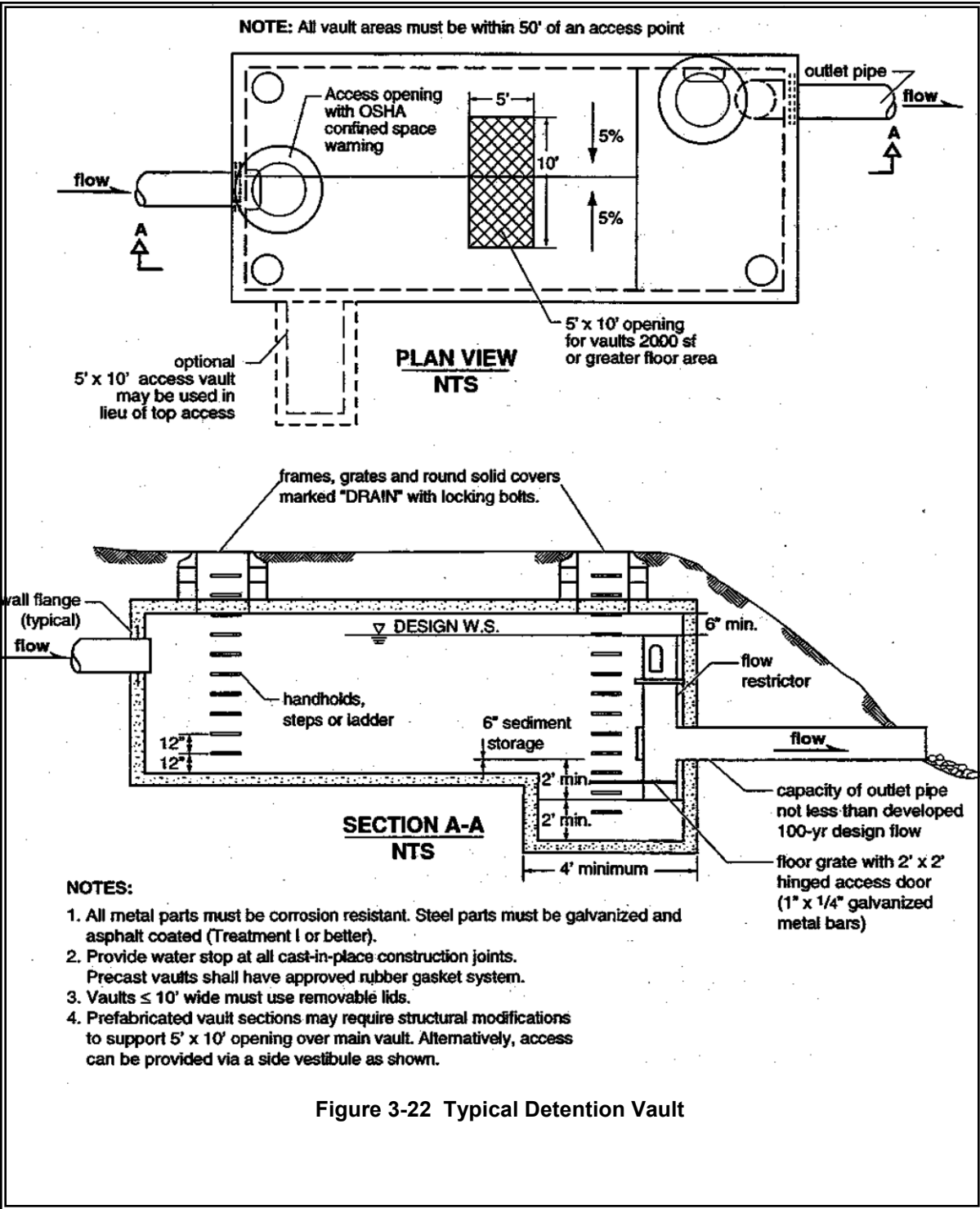
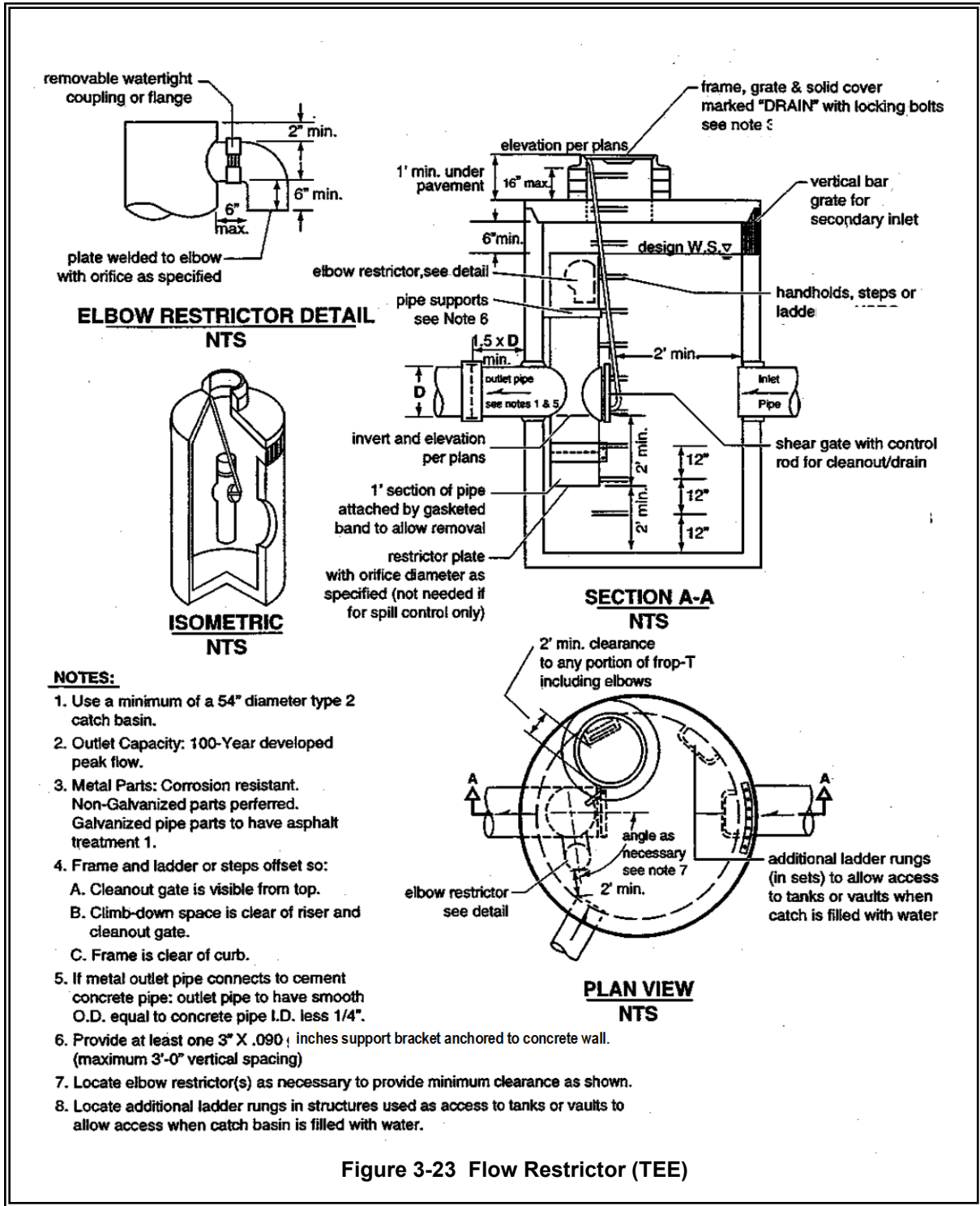


Figure 3-22 Typical Detention Vault



**NOTES:**

1. Use a minimum of a 54" diameter type 2 catch basin.
2. Outlet Capacity: 100-Year developed peak flow.
3. Metal Parts: Corrosion resistant. Non-Galvanized parts preferred. Galvanized pipe parts to have asphalt treatment 1.
4. Frame and ladder or steps offset so:
  - A. Cleanout gate is visible from top.
  - B. Climb-down space is clear of riser and cleanout gate.
  - C. Frame is clear of curb.
5. If metal outlet pipe connects to cement concrete pipe: outlet pipe to have smooth O.D. equal to concrete pipe I.D. less 1/4".
6. Provide at least one 3" X .090 inch support bracket anchored to concrete wall. (maximum 3'-0" vertical spacing)
7. Locate elbow restrictor(s) as necessary to provide minimum clearance as shown.
8. Locate additional ladder rungs in structures used as access to tanks or vaults to allow access when catch basin is filled with water.

**Figure 3-23 Flow Restrictor (TEE)**

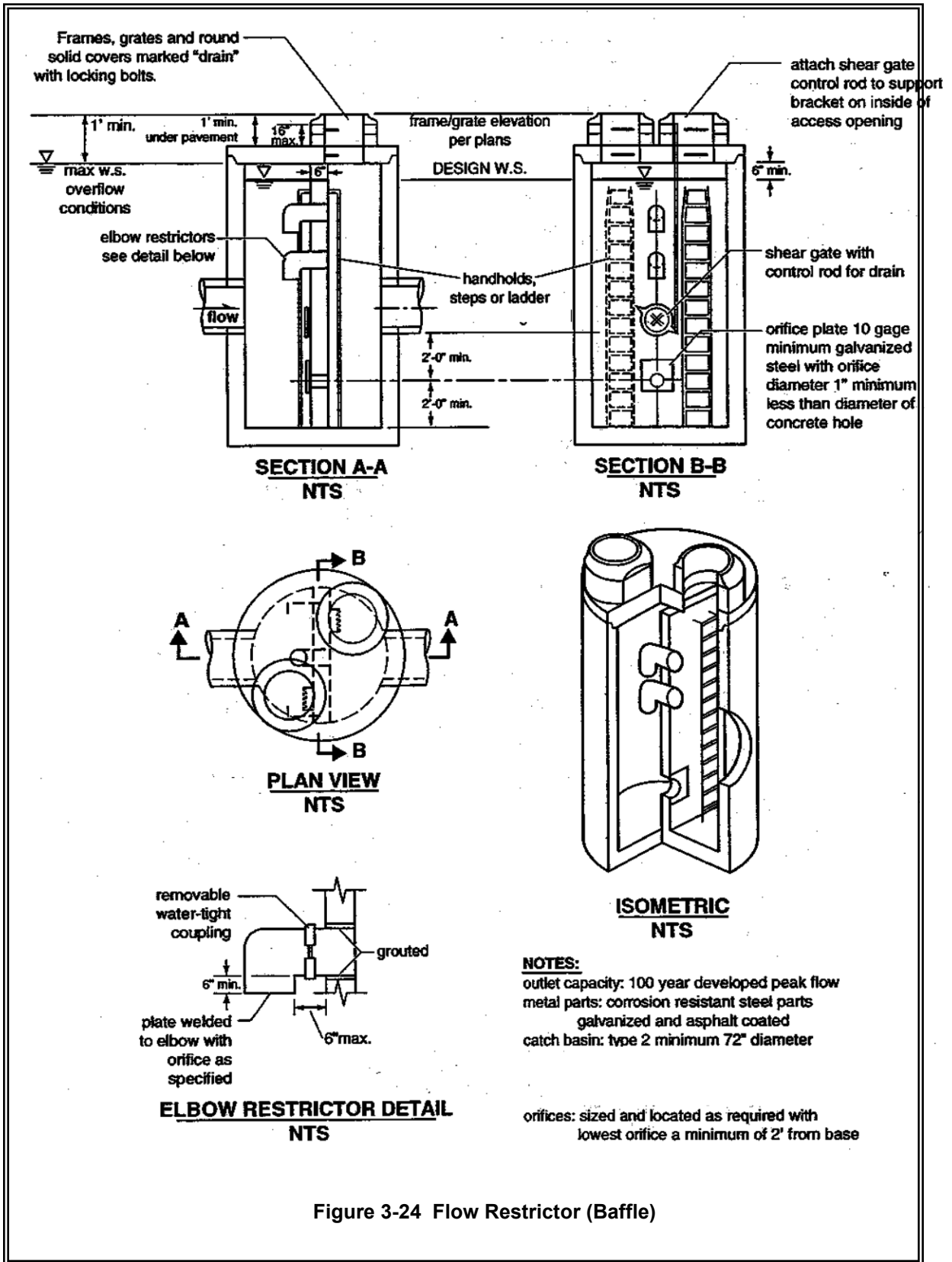
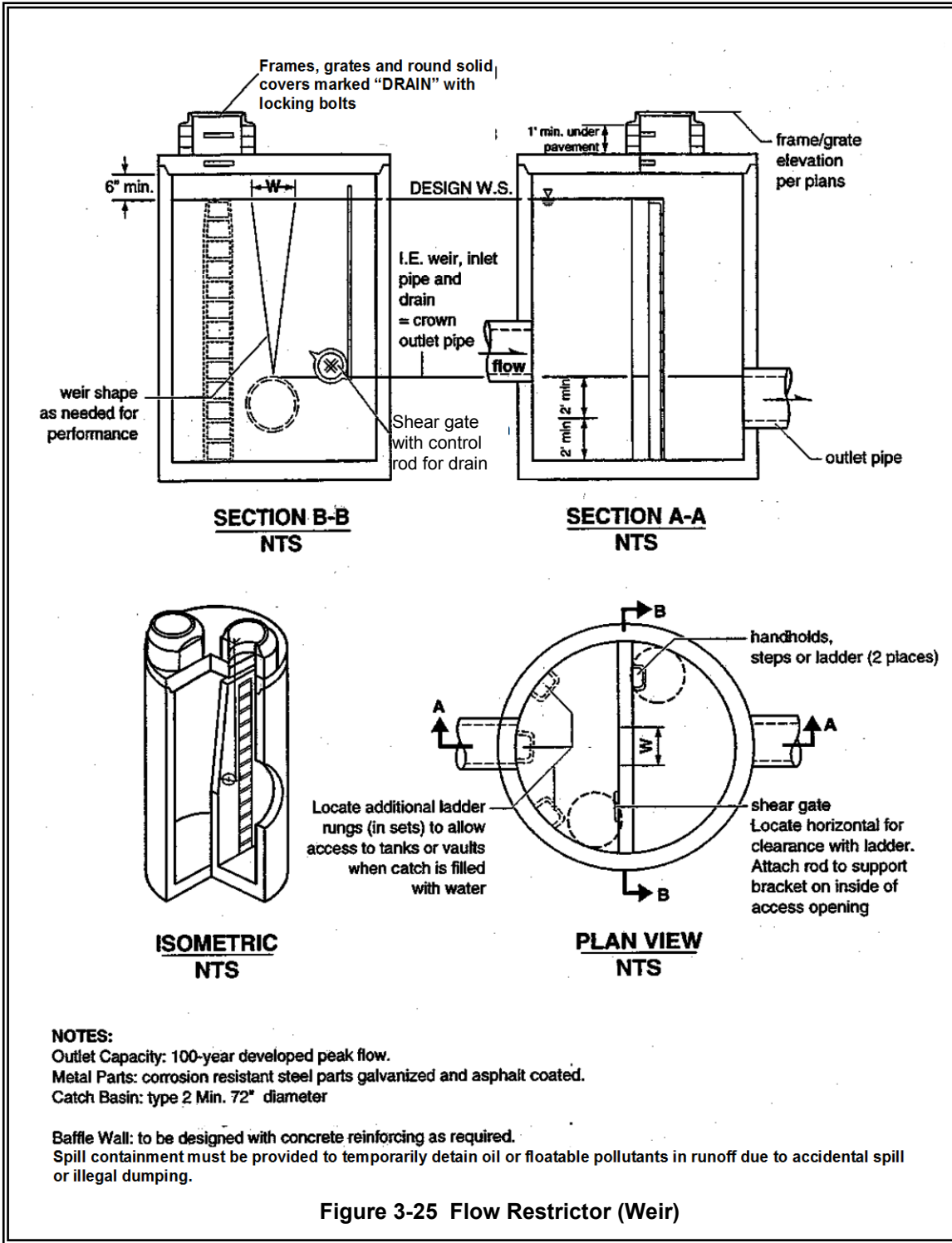
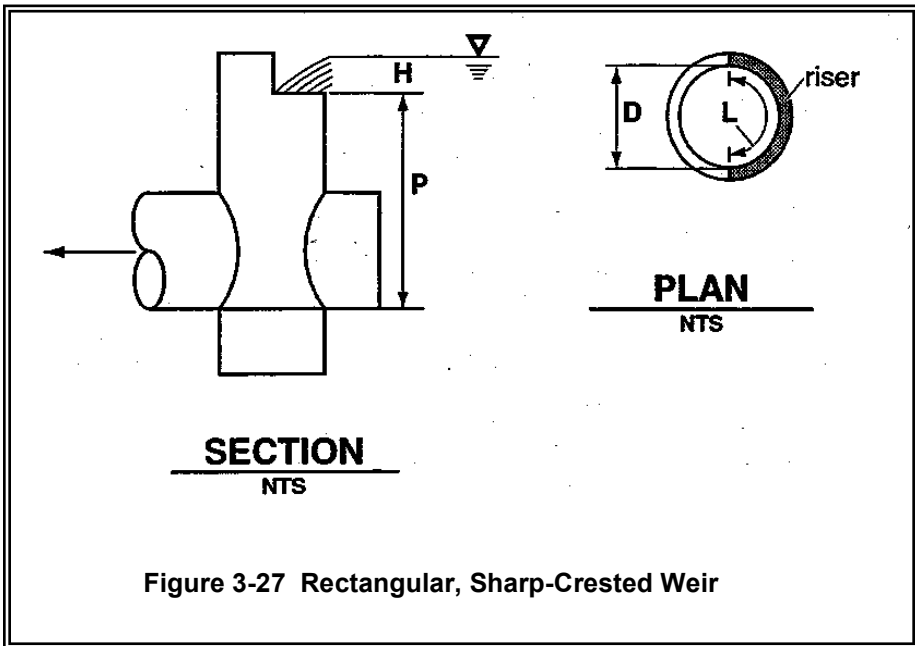
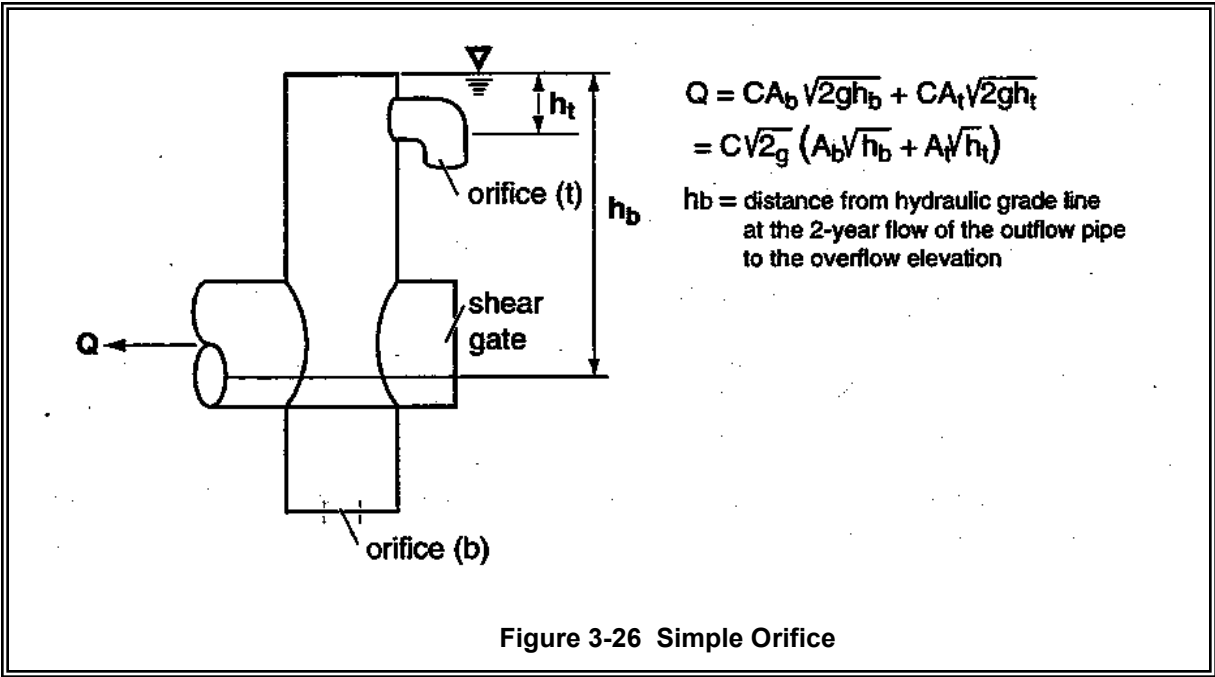
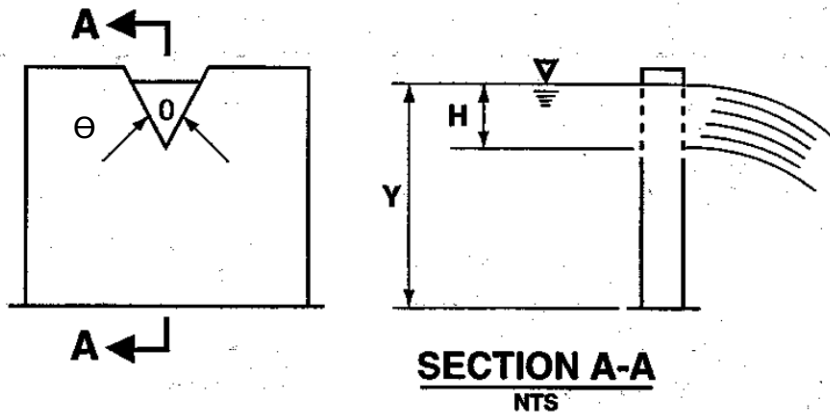


Figure 3-24 Flow Restrictor (Baffle)







$$Q = C_d(\tan \theta/2)Y^{5/2}, \text{ in cfs}$$

$$Q = C_d(\tan \theta/2)H^{5/2}, \text{ in cfs}$$

Where values of  $C_d$  may be taken from the following chart:

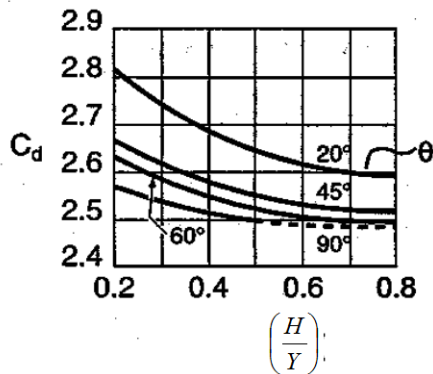


Figure 3-28 V-Notch, Sharp-Crested Weir

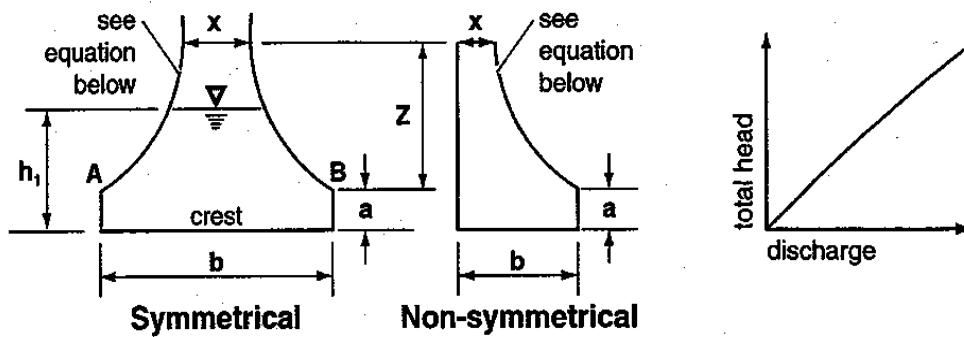
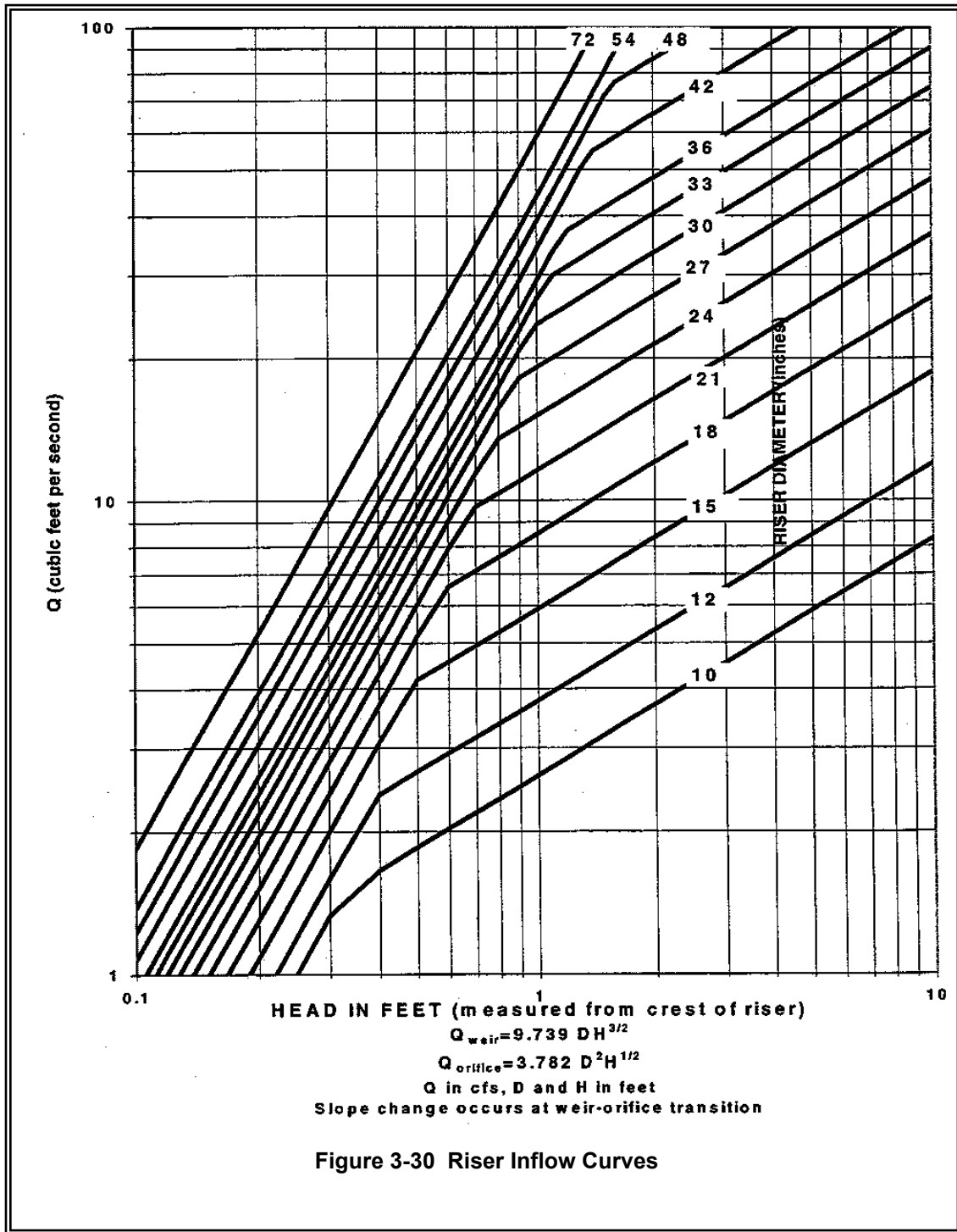


Figure 3-29 Sutro Weir





# Chapter 4 – Conveyance System Design and Hydraulic Analysis

---

## 4.1 Purpose

This chapter presents acceptable methods for the analysis and design of conveyance systems. Conveyance systems can be separated into the following categories:

- Pipe systems
- Culverts
- Open Channels (ditches, swales)
- Outfalls

The purpose of a conveyance system is to drain surface water, up to a specific design flow, from properties so as to provide protection to property and the environment. This chapter contains detailed design criteria methods of analysis and standard details for all components of a conveyance system. A complete basic understanding of hydrology and of the principles on which the methodology of hydrologic analysis is based is essential for the proper and accurate application of methods used in designing conveyance systems.

## 4.2 Required vs. Recommended Design Criteria

Both required and recommended design criteria are presented in this chapter. **Required** design criteria stated using “**shall**” or “**must**” are mandatory, to be followed unless there is a good reason to deviate as allowed by the Exceptions process of Section 3.7 of Volume I. **Recommended** design criteria are stated as part of the required design criteria using the language “**should**” or “**may**.”

## 4.3 Conveyance Analysis Requirements

The project engineer shall provide calculations demonstrating the adequacy of all the project’s existing and proposed surface water conveyance system components. The project engineer shall provide calculations regarding all off-site flows as required by Volume I. All relevant work/calculations shall be submitted for City review as part of a permit submittal.

### 4.3.1 On-site Analysis

All proposed on-site surface water conveyance systems shall be sized to meet the required design event per Section 4.4 below.

#### 4.3.2 Offsite Analysis (1/4 Downstream Analysis)

##### Per Volume I, Section 3.6.1 – Additional Requirements #1 – Off-site Analysis and Mitigation –

**“...A quantitative analysis will be required for all projects creating 10,000 square feet or more of new impervious area that do not provide detention per the standard requirements. Also, all projects that wish to make a contribution in lieu of providing flow control shall provide a quantitative analysis. The City may also require a quantitative analysis for any project deemed to need additional downstream information.”**

The engineer must field survey all existing storm drainage systems downstream from the project and determine that the capacity of the drainage system(s) is adequate to handle the existing flows, flows generated by the proposed project, and any overflow. Adequacy will be evaluated based on conveyance capacity, flooding problems, erosion damage or potential, amount of freeboard in channels and pipes, and storage potential within the system. **All existing and proposed off-site surface water conveyance systems shall be sized to meet the required design event per section 4.4 below.**

The offsite analysis may be stopped sooner than the required ¼-mile downstream if the analysis reaches a City identified trunk-line. Storm drainage pipe greater than or equal to 24 inches in diameter are generally considered trunk lines. However, in the Tideflats areas or where minimal grades necessitated the use of a larger pipe to maintain flows, the City may not consider a pipe greater than or equal to 24 inches as a trunk-line. Contact Environmental Services for final determination of this criteria.

If a capacity problem or streambank erosion problem is encountered, the release rate from the project will be restricted per Minimum Requirement #7 – Flow Control. The design shall meet the requirements of Chapter 3 of this Volume. Instead of providing flow control the Proponent may be allowed to correct the downstream problem.

#### 4.4 Design Event

The design events for all existing and new conveyance systems are as follows:

- All public and private pipe systems less than 24 inches in diameter shall be designed to convey the 10-year, 24-hour peak flow rate without surcharging.
- All public and private pipe systems greater than or equal to 24-inches in diameter shall be designed to convey the 25-year, 24-hour peak flow rate without surcharging.

- Culverts shall convey the 25-year, 24-hour peak flow rate without submerging the culvert inlet (i.e.  $HW/D \leq 1$ ).
- Constructed and natural channels shall contain the 100-year, 24-hour storm event.
- All conveyance systems shall be designed for fully developed conditions. The fully developed conditions for the project site shall be derived from the percentages of proposed and existing impervious area. For off-site tributary areas, typical percentages of impervious area for fully developed conditions are provided in Table 4.1. Conveyance systems shall be modeled as if no on-site detention is provided up-stream.
- *Note: When a project is proposed for the Tidelands in Tacoma, the site grades and storm drainage elevations shall be checked against tidal records to evaluate the ability of the system to carry the additional flow via a backwater analysis. Tides can be as much as 2 feet higher than predicted due to influence of low barometric pressure.*

## 4.5 Method of Analysis

**For a full description of the information required for preparing a Stormwater Site Plan consult Chapter 3 Section 3.6 and Chapter 4 of Volume I. The below is intended as a brief summary of the information needed for a hydraulic analysis.**

City of Tacoma drainage maps, record drawings and Proponent site surveys may be used as the basis for determining the capacity of existing systems. For naturally occurring drainage systems, drainage ditches, or undeveloped drainage courses, the engineer must take into account the hydraulic capacity of the existing drainage course and environmental considerations such as erosion, siltation, and increased water velocities or water depths.

Describe capacities, design flows, and velocities in each reach. Describe required materials or specifications for the design (e.g. rock lined for channels when velocity is exceeded; high density polyethylene pipe needed for steep slope). Comprehensive maps showing the flow route and basins for both the on-site and off-site surface water (for the minimum 1/4 mile downstream distance) must be included in the storm drainage calculations.

If hydrologic modeling is required, the Project Engineer shall state methods, assumptions, model parameters, data sources, and all other relevant information to the analysis. If model parameters are used that are outside the standards of practice, or if parameters are different than those standards, justify the parameters. Copies of all calculations for capacity of channels, culverts, drains, gutters and other conveyance systems shall be included with the Surface Water Site Plan. If used, include all standardized graphs and tables and indicate how they were

used. Show headwater and tailwater analysis for culverts when necessary. Provide details on references and sources of information used.

#### 4.5.1 Rational Method

This method shall only be used for preliminary pipe sizing and capacity analysis. For flow control sizing derivations see Chapter 2 of Volume III. For water quality treatment sizing and flows see Chapter 2 of Volume III and Chapter 4 of Volume V.

The Rational Method is a simple, conservative method for analyzing and sizing conveyance elements serving small drainage subbasins, subject to the following specific limitations:

- Only for use in predicting peak flow rates for sizing conveyance elements (**not for use in sizing flow control or treatment facilities**)
- Drainage subbasin area,  $A$ , cannot exceed 10 acres for a single peak flow calculation
- The time of concentration,  $T_c$ , must be computed using the method described below and cannot exceed 100 minutes. It is also set equal to 6.3 minutes when computed to be less than 6.3 minutes.

*Note: Unlike other methods of computing times of concentration, the 6.3 minutes is not an initial collection time to be added to the total computed time of concentration.*

#### Rational Method Equation

The following is the traditional Rational Method equation:

$$Q_R = CI_RA \quad (4-1)$$

where  $Q_R$  = peak flow (cfs) for a storm of return frequency  $R$   
 $C$  = estimated runoff coefficient (ratio of rainfall that becomes runoff)  
 $I_R$  = peak rainfall intensity (inches/hour) for a storm of return frequency  $R$   
 $A$  = drainage subbasin area (acres)

#### “C” Values

The allowable runoff coefficients to be used in this method are shown in Table 4.3 by type of land cover. These values were selected following a review of the values previously accepted by Tacoma for use in the Rational Method and as described in several engineering handbooks. The value for single family residential areas were computed as composite values (as illustrated in the following equation) based on the estimated percentage of coverage by roads, roofs, yards, and unimproved areas for each density. For drainage basins containing several land cover types,

the following formula may be used to compute a composite runoff coefficient,  $C_c$ :

$$C_c = (C_1A_1 + C_2A_2 + \dots + C_nA_n) / A_t \quad (4-2)$$

where  $A_t$  = total area (acres)  
 $A_{1,2,\dots,n}$  = areas of land cover types (acres)  
 $C_{1,2,\dots,n}$  = runoff coefficients for each area land cover type

### “ $I_R$ ” Peak Rainfall Intensity

The peak rainfall intensity,  $I_R$ , for the specified design storm of return frequency,  $R$ , is determined using a unit peak rainfall intensity factor,  $i_R$ , in the following equation:

$$I_R = (P_R)(i_R) \quad (4-3)$$

where  $P_R$  = the total precipitation at the project site for the 24-hour duration storm event for the given return frequency. Refer to Table 4.2 for  $P_R$  values. Total precipitation can be found on the Isopluvial Maps located in Appendix III-A..

$i_R$  = the unit peak rainfall intensity factor

The unit peak rainfall intensity factor,  $i_R$ , is determined by the following equation:

$$i_r = (a_r)(T_c)^{(-b_R)} \quad (4-4)$$

where  $T_c$  = time of concentration (minutes), calculated using the method described below and subject to equation limitations ( $6.3 < T_c < 100$ )  
 $a_R, b_R$  = coefficients from Table 4.2 used to adjust the equation for the design storm return frequency  $R$

This “ $i_R$ ” equation was developed by DNR from equations originally created by Ron Mayo, P.E. It is based on the original **Renton/Seattle Intensity/Duration/Frequency (I.D.F.) curves**. Rather than requiring a family of curves for various locations in King County, this equation adjusts proportionally the Renton/Seattle I.D.F. curve data by using the 24-hour duration total precipitation isopluvial maps. This adjustment is based on the assumption that the localized geo-climatic conditions that control the total volume of precipitation at a specific location also control the peak intensities proportionally.

The City of Tacoma has provided Table 4.2, which contains the various variables to be used when determining  $I_R$  for use in the rational method. Variable  $P_R$  is derived from the National Oceanic and Atmospheric Administration (NOAA) isopluvial maps for Tacoma contained within

Appendix III-A. Certain of these isopluvial lines are contiguous with rainfall contours on isopluvials contained within the 1998 King County Surface Water Design Manual. The City believes adoption of the “ $i_R$ ” equation and its proportional adjustment of the Renton/Seattle I.D.F. curve data is applicable for the Tacoma area if the tabulated  $P_R$  (Table 4.2) is used in the derivation of the peak rainfall intensity.

*Note: Due to the mathematical limits of the equation coefficients, values of  $T_c$  less than 6.3 minutes or greater than 100 minutes cannot be used. Therefore, real values of  $T_c$  less than 6.3 minutes must be assumed to be equal to 6.3 minutes, and values greater than 100 minutes must be assumed to be equal to 100 minutes.*

### “ $T_c$ ” Time of Concentration

The time of concentration is defined as the time it takes runoff to travel overland (from the onset of precipitation) from the most hydraulically distant location in the drainage basin to the point of discharge. *Note: When  $C_c$  (see Equation 4-2) of a drainage basin exceeds 0.60, it may be important to compute  $T_c$  and peak rate of flow from the impervious area separately.* The computed peak rate of flow for the impervious surface alone may exceed that for the entire drainage basin using the value at  $T_c$  for the total drainage basin. The higher of the two peak flow rates shall then be used to size the conveyance element.

$T_c$  is computed by summation of the travel times  $T_t$  of overland flow across separate flowpath segments defined by the six categories of land cover listed in Table 4.4, which were derived from a chart published by the Soil Conservation Service in 1975. The equation for time of concentration is:

$$T_c = T_1 + T_2 + \dots + T_n \quad (4-5)$$

where  $T_{1,2\dots n}$  = travel time for consecutive flowpath segments with different categories or flowpath slope

Travel time for each segment,  $t$ , is computed using the following equation:

$$T_t = \frac{L}{60V} \quad (4-6)$$

where  $T_t$  = travel time (minutes) *Note:  $T_t$  through an open water body (such as a pond) shall be assumed to be zero with this method.*

$L$  = the distance of flow across a given segment (feet)

$V$  = average velocity (fps) across the land cover =  $k_R \cdot \sqrt{s_0}$

where  $k_R$  = time of concentration velocity factor; see Table 4.4  
 $s_0$  = slope of flowpath (feet/feet)





#### **4.5.2 Minimum Computational Standards (SBUH or Continuous Runoff Model Methods)**

The minimum computational standards for water quality treatment and flow control can be found in Chapter 3 of Volume I and Chapter 2 of this Volume. These methods may also be used for calculating the design flows necessary for conveyance elements. There are computer programs capable of computing design flows and stage/discharge tables necessary for design of treatment and flow control facilities including the Department of Ecology's Western Washington Hydraulic Model.

The project engineer is responsible for providing information describing how the program was used, assumptions the program makes and descriptions of all variables, columns, rows, summary tables, and graphs. The most current version of any software program shall be used for analysis. Tacoma may find specific programs not acceptable for use in design. Please check with Environmental Services, Science and Engineering Division, to confirm the applicability of a particular program prior to starting design.

### **4.6 Pipes, Culverts and Open Channels**

This section presents the methods, criteria and details for analysis and design of pipe systems, culverts, and open channel conveyance systems.

#### **4.6.1 Pipe Systems**

Pipe systems are networks of storm drain pipes, catch basins, manholes, inlets, and outfalls, designed and constructed to convey surface water. The hydraulic analysis of flow in storm drainage pipes typically is limited to gravity flow; however in analyzing existing systems it may be necessary to address pressurized conditions. A properly designed pipe system will maximize hydraulic efficiency by utilizing proper material, slope, and pipe size.

##### **4.6.1.1 Design Flows**

Design flows for sizing or assessing the capacity of pipe systems shall be determined using the hydrologic analysis methods described in Section 4.4 – 4.6 of this chapter. Other single event or continuous runoff models as described in Chapter 2 of this Volume may be used to determine design flows.

##### **4.6.1.2 Conveyance Capacity**

Two methods of hydraulic analysis using Manning's Equation are required by the City of Tacoma for the analysis of pipe systems. First, the **Uniform Flow Analysis** method is used for preliminary design and analysis of pipe systems. Second, the **Backwater Analysis** method is used to analyze both proposed and existing pipe systems to verify

adequate capacity. See section 4.4 for the required design events for pipe systems.

*Note: When a project is proposed for the Tideflats in Tacoma, the site grades and storm drainage elevations shall be checked against tidal records to evaluate the ability of the system to carry the additional flow. Tides can be as much as 2 feet higher than predicted due to influence of low barometric pressure.*

### Uniform Flow Analysis

This method is typically used for preliminary sizing of new pipe systems to convey the design flow as calculated from the required design event from Section 4.4.

Assumptions:

- Flow is uniform in each pipe (i.e., depth and velocity remain constant throughout the pipe for a given flow).
- Friction head loss in the pipe barrel alone controls capacity. Other head losses (e.g., entrance, exit, junction, etc.) and any backwater effects or inlet control conditions are not specifically addressed.
- All pipes shall be designed for fully developed conditions. The fully developed conditions shall be derived from the percentages of impervious area provided in Table 4.1.
- All pipes shall be modeled as if no on-site detention is provided upstream.

Each pipe within the system shall be sized and sloped such that **its barrel capacity at normal full flow** is equal to or greater than the design flow calculated from the appropriate design storm as identified in Section 4.4. The nomographs in Figure 4-1 can be used for approximate sizing of the pipes or Manning's Equation can be solved for pipe size directly:

$$V = \frac{1.49}{n} R^{2/3} S^{1/2} \quad (4-7)$$

or use the continuity equation,  $Q = A \cdot V$ , such that

$$Q = \frac{1.49}{n} A R^{2/3} S^{1/2} \quad (4-8)$$

where

- Q = discharge (cfs)
- V = velocity (fps)
- A = area (sf)
- n = Manning's roughness coefficient; see Table 4.5 below
- R = hydraulic radius = area/wetted perimeter
- S = slope of the energy grade line (ft/ft)

For **pipes flowing partially full**, the actual velocity may be estimated from the hydraulic properties shown in Figure 4-2 by calculating  $Q_{full}$  and  $V_{full}$  and using the ratio of  $Q_{design}/Q_{full}$  to find  $V$  and  $d$  (depth of flow).

Table 4.5 provides the recommended Manning's "n" values for preliminary design for pipe systems. *NOTE: The "n" values for this method are 15% higher in order to account for entrance, exit, junction, and bend head losses.*

### **Backwater Analysis**

A backwater analysis shall be required when the design depth of flow is greater than 90% of the pipe inside diameter. The backwater analysis method described in this section is used to analyze the capacity of both proposed and existing pipe systems to convey the required design flow (i.e., either the 10-year or 25-year peak flow as required in section 4.4). The backwater analysis shall verify that the pipe system meets the following conditions:

- For the 25-year event, there shall be a minimum of 0.5 feet of freeboard between the water surface and the top of any manhole or catch basin.
- For the 100-year event, overtopping of the pipe conveyance system may occur, however, the additional flow shall not extend beyond half the lane width of the outside lane of the traveled way and shall not exceed 4 inches in depth at its deepest point. Off-channel storage on private property is allowed with recording of the proper easements. When this occurs, the additional flow over the ground surface is analyzed using the methods for open channels described in Sections 4.4 and 4.6.3 and added to the flow capacity of the pipe system.

This method is used to compute a simple backwater profile (hydraulic grade line) through a proposed or existing pipe system for the purposes of verifying adequate capacity. It incorporates a re-arranged form of Manning's equation expressed in terms of friction slope (slope of the energy grade line in ft/ft). The friction slope is used to determine the head loss in each pipe segment due to barrel friction, which can then be combined with other head losses to obtain water surface elevation at all structures along the pipe system.

The backwater analysis begins at the downstream end of the pipe system and is computed back through each pipe segment and structure upstream. The friction, entrance, and exit head losses computed for each pipe segment are added to that segment's tailwater elevation (the water surface elevation at the pipes' outlet) to obtain its outlet control headwater elevation. This elevation is then compared with the inlet control headwater elevation, computed assuming the pipe's inlet alone is controlling capacity using the methods for inlet control presented in Section 4.6.2. The condition that creates the highest headwater elevation

determines the pipe's capacity. The approach velocity head is then subtracted from controlling headwater elevation, and the junction and bend head losses are added to compute the total headwater elevation, which is then used as the tailwater elevation for the upstream pipe segment.

The Backwater Calculation Sheet in Figure 4-3 can be used to compile the head losses and headwater elevations for each pipe segment. The numbered columns on this sheet are described in Figure 4-4. An example calculation is performed in Figure 4-5.

*Note: This method should not be used to compute stage/discharge curves for level pool routing purposes. See Chapter 2 of this Volume.*

### **Inlet Grate Capacity**

The *Washington State Department of Transportation (WSDOT) Hydraulics Manual* can be used in determining the capacity of inlet grates when capacity is of concern. When verifying capacity, assume:

- Grate areas on slopes are 80 percent free of debris, and “vaned” grates are 95 percent free.
- Grate areas in sags or low spots are 50 percent free of debris, and “vaned” grates, 75 percent free.

### **Computer Applications**

There are several different computer programs capable of computing Backwater profiles through a proposed or existing pipe system. The project engineer is responsible for providing information describing how the program was used, assumptions the program makes and descriptions of all variables, columns, rows, summary tables, and graphs. The most current version of any software program shall be used for analysis. Tacoma may find specific programs not acceptable for use in design. Please check with Environmental Services, Science and Engineering Division, to confirm the applicability of a particular program prior to starting design.

#### **4.6.1.3 Pipe Specifications**

All pipe material, joints, and protective treatment shall be in accordance with Section 9.05 of the latest version of the WSDOT/APWA Standard Specifications and AASHTO and ASTM treatment standards as amended by the City of Tacoma. The Project Proponent is responsible for contacting the City to determine what the allowable pipe materials are for a specific project.

### **Pipe Materials**

All storm drainage pipe to be installed in public right-of-ways or as a connection to the municipal system shall be either:

- Rubber-gasketed concrete pipe (12-inch maximum diameter), or
- Rubber gasketed reinforced concrete pipe, minimum 10-inch diameter, or
- Polyvinyl chloride (PVC) sewer pipe (ASTM D3034 for PVC less than or equal to 15-inches or ASTM F679 for PVC greater than 15-inch), or
- High-density polyethylene pipe (HDPP). Pipe must comply with requirement of Type III C5P34 per ASTM D1248 and have the PPI recommended designation of PE3408 and have an ASTM D3350 cell classification of 345434C or 345534C. Pipe shall have a manufacturer's recommended hydrostatic design stress rating of 800 psi based on a material with a 1600 psi design basis determined in accordance with ASTM D2837-69. Pipe shall have a suggested design working pressure of 50 psi at 73.4 degrees F and SDR of 32.5.
- Ductile iron (class 50 or 52).

*Note: Designs utilizing HDP pipe shall include considerations of the material's thermal expansion/contraction properties for anchoring.*

Galvanized, aluminized, and/or corrugated iron or steel pipes are not allowed within the public right-of-way or as a connection to the Municipal system. **ADS N-12 plastic pipe is NOT currently accepted by the City of Tacoma within the public right-of-way.**

If other pipe materials are to be used in projects not within the public right-of-way or as a connection to the municipal system, they shall meet the minimum requirements of the following and shall have prior City approval:

- Galvanized corrugated iron or steel (with Treatment 1 through 6)
- Galvanized steel spiral rib pipe (with Treatment 1 through 6)
- Corrugated aluminum pipe
- Aluminum spiral rib pipe
- Aluminized Type 2 corrugated steel (meeting AASHTO treatment M274 and M 56)
- Corrugated high density polyethylene pipe (CPEP) - smooth interior (maximum 24-inch diameter) meeting AASHTO standard M-294
- Corrugated high density polyethylene pipe (CPEP) - single wall, fully corrugated meeting AASHTO standard M-252 (permitted only outside public right-of-way and for use in temporary storm sewer systems and as downspout/footing/yard drain collectors on private property)
- Polyvinyl chloride (PVC) sewer pipe (SDR 35, meeting requirements of ASTM D3034)

## Pipe Sizes

The following pipe sizes shall be used for pipe systems to be maintained by the City of Tacoma: 8-inch (only used for catch basin leads or in privately maintained systems), 10-inch, 12-inch, 15-inch, 18-inch, 21-inch, 24-inch, and 30-inch. For Pipes larger than 30-inch increasing increments of 6-inch intervals shall be used (36-inch, 42-inch, 48-inch, etc.).

Storm sewer pipe used for private roof/footing/yard drain systems can be less than 10 inches in diameter if sized for the appropriate design flows with no surcharging. Feasibility of maintenance should always be considered when designing smaller pipe diameters for private systems.

## Changes in Pipe Sizes

- Pipe direction changes or size increases or decreases are only allowed at manholes and catch basins.
- Downsizing of pipes is only allowed under special conditions (i.e. no hydraulic jump can occur; downstream pipe slope is significantly greater than the upstream slope; velocities remain in the 3 - 8 fps range, etc.).
- Where a minimal fall is necessary between inlet and outlet pipes in a structure, pipes must be aligned vertically by one of the following in order of preference:
  - a) Match pipe crowns
  - b) Match 80% diameters of pipes
  - c) Match pipe inverts or use City approved drop connection

## Pipe Alignment and Depth

- Pipes must be laid true to line and grade with no curves, bends, or deflections in any direction.

**Exception:** *Vertical deflections in HDPP and Ductile Iron pipe with flanged restrained mechanical joint bends (not greater than 30%) on steep slopes are allowed provided the pipe adequately drains.*
- A break in grade or alignment or changes in pipe material shall occur only at catch basins or manholes.
- For the standard main alignment contact the City's Construction Division.
- The standard depth for new mains measures six (6) feet from the center of the pipe to the main street surface.
- The project engineer shall consult with the City for the potential of a future extension of the storm system. In this case, the City may require modifications to the depth or alignment.

- Maximum spacing of catch basins and manholes for continuous storm sewer systems shall be 200 feet for pipe grades up to 0.3% (Minimum slope without prior approval is 0.5%). When pipe grades are 0.3% or greater, maximum spacing shall be 350 feet.
- Maximum surface runs between inlet structures on the paved roadway surface shall be 350 feet.

### **Pipe Slopes and Velocities**

- The slope of the pipe shall be set so that a minimum velocity of 2 feet per second can be maintained at full flow.
- A minimum slope for all pipes shall be 0.5%.
- Maximum slopes, velocities, and anchor spacings are shown in Table 4.6. If velocities exceed 15 feet per second for the conveyance system design event, provide anchors at bends and junctions.

### **Pipes on Steep Slopes**

- Steep slopes (greater than 25%) shall require all drainage to be piped from the top to the bottom in High Density Polyethylene (HDP) pipe (butt-fused) or ductile iron pipe welded or mechanically restrained. Additional anchoring design is required for these pipes.
- High Density Polyethylene pipe systems longer than 100 feet must be anchored at the upstream end if the slope exceeds 25% and the downstream end must be placed in a minimum 4 foot long section of the next larger pipe size. This sliding sleeve connection allows for the high thermal expansion/contraction coefficient of the pipe material.

*Note: The City may waive these minimums in cases where topography and existing drainage systems make it impractical to meet the standard.*

### **Structures**

For the purposes of this Manual, all catch basins and manholes shall meet WSDOT standards such as Type 1L, Type 1, and Type 2. Table 4.7 presents the structures and pipe sizes allowed by size of structure. The following criteria shall be used when designing a conveyance system that utilizes catch basins or manholes:

- Catch basin (or manhole) diameter shall be determined by pipe diameter and orientation at the junction structure. A plan view of the junction structure, drawn to scale, will be required when more than four pipes enter the structure on the same plane, or if angles of approach and clearance between pipes is of concern. The plan view (and sections if necessary) must insure a minimum distance (of solid concrete wall) between pipe openings of 8 inches for 48-inch and 54-inch diameter catch basins and 12 inches for 72-inch and 96-inch diameter catch basins

- Unless otherwise required by the City, Type 1 catch basins shall be used at the following locations or for the following situations:
  - When overall structure height does not exceed 8 feet or when invert depth does not exceed five (5) feet below rim.
  - When pipe sizes do not exceed 15 inches and connect at right angles to the long side of the structure; or 12 inches connecting to the short side.
  - When all pipes tying into the structure connect at or very near to right angles.
- Unless otherwise required by the City, Type 1L catch basins must be used at the following locations or for the following situations:
  - When overall structure height does not exceed 8 feet or when invert depth does not exceed five (5) feet below rim.
  - When any pipes tying into the structure exceed 21 inches connecting to the long side, or 18 inches connecting to the short side at or very near to right angles.
- Unless otherwise required by the City, Type 2 (48-inch minimum diameter) catch basins or manholes shall be used at the following locations or for the following situations:
  - When overall structure height does not exceed 15 feet.
  - When all pipes tying into the structure do not exceed the limits set forth by the manufacturers. Type 2 catch basins or manholes over 4 feet in height shall have standard ladders.
- The maximum slope of ground surface for a radius of 5 feet around a catch basin grate shall be 3:1. The preferred slope is 5:1 to facilitate maintenance access.
- Catch basin (or manhole) evaluation of structural integrity for H-20 loading will be required for multiple junction catch basins and other structures that exceed the recommendations of the manufacturers.
- Catch basins shall be provided within 50 feet of the entrance to a pipe system to provide for silt and debris removal.
- Catch basins should be located:
  - At the low point of any sag vertical curve or grade break where the grade of roadway transitions from a negative to a positive grade.
  - Such that a maximum of 350 linear feet of paved street is collected by a single catch basin.
  - Prior to any intersection such that a minimal amount of water flows across the intersection, through a curb ramp, or around a street return.
  - Prior to transitions from a typical crown to a full warp through a down hill grade.



- Catch basins should not be placed in areas of expected pedestrian traffic. The engineer should avoid placing a catch basin in crosswalks, adjacent to curb ramps, or in the gutter of a driveway. Care should be taken on the part of the engineer to assure that the catch basin will not be in conflict with any existing or proposed utilities.
- All catch basins, inlets, etc. shall be marked as shown in Appendix III-C.

### **Pipe Clearances**

Horizontal: A minimum of 5 feet horizontal separation should be maintained between the storm main and all water or sanitary sewer mains.

Vertical: Where crossing an existing or proposed utility or sanitary sewer main, the alignment of the storm system should be such that the two systems cross as close to perpendicular as possible. Where crossing a sanitary sewer main, provide a minimum 18 inches of vertical separation. For crossings of water mains refer to the Water Rates and Regulations for Supply and Use of Water (TMC). The minimum vertical separation for a storm main crossing any other utility shall be 6 inches. *Note: Where the vertical separation of two parallel systems exceeds the horizontal separation, additional horizontal separation may be required to provide future access to the deeper system.*

### **Pipe Cover**

- Suitable pipe cover over storm pipes in road rights-of-way shall be calculated for HS-20 loading by the Project Engineer. Pipe cover is measured from the finished grade elevation down to the top of the outside surface of the pipe. Pipe manufacturer's recommendations are acceptable if verified by the Project Engineer.
- PVC (ASTM D3034 - SDR 35) minimum cover shall be three feet in areas subject to vehicular traffic; maximum cover shall be 30 feet or per the manufacturer's recommendations and as verified with calculations from the Project Engineer.
- Pipe cover in areas not subject to vehicular loads, such as landscape planters and yards, may be reduced to a 1-foot minimum.
- Catch basin evaluation of structural integrity for H-20 loading will be required for multiple junction catch basins and other structures that exceed the recommendations of the manufacturers.

### **System Connections**

Connections to a pipe system shall be made only at catch basins or manholes. No wyes or tees are allowed except on private roof/footing/yard drain systems on pipes 8 inches in diameter, or less, with clean-outs upstream of each wye and tee.

Where a minimal fall is necessary between inlet and outlet pipes in a structure, pipes must be aligned vertically by one of the following in order of preference:

- a) Match pipe crowns
- b) Match 80% diameters of pipes
- c) Match pipe inverts or use City approved drop inlet connection

Where inlet pipes are higher than outlet pipes, drop manhole connections may be required or increased durability in the structure flow path may be required.

Private connections to the City storm system shall be at a drainage structure (i.e. catch basin or manhole) and only if sufficient capacity exists. Tee connections into the side of a pipe shall not be permitted. *Note: Roof downspouts may be discharged through the curb into the roadway gutter or connected into a drainage structure. Roof downspouts may **not** be connected directly into the side of a storm drainage pipe.*

### **Debris Barriers**

Access barriers are required on all pipes 12 inches and larger exiting a closed pipe system. Debris barriers (trash racks) are required on all pipes entering a pipe system. See Figure 4-10 for required debris barriers on pipe ends outside of roadways and for requirements on pipe ends (culverts) projecting from driveways or roadway side slopes.

## **4.6.2 Culverts**

Culverts are relatively short segments of pipe of circular, elliptical, rectangular, or arch cross section. They are usually open at both ends and are placed under road embankments or driveways to convey surface water flow safely under the embankment. They may be used to convey flow from constructed or natural channels including streams. The City's Critical Areas Preservation Ordinance contains the definitions of streams and requirements for crossing of streams. In addition to those requirements and the design criteria described below, other agencies such as the Washington State Department of Fish and Wildlife (WDFW) may have additional requirements, which will affect the design of proposed culverts.

### **4.6.2.1 Design Flows**

Design flows for sizing or assessing the capacity of culverts shall be determined using the hydrologic analysis methods described in Section 4.4 – 4.6 of this chapter. *Note: Culverts in stream corridors must meet any fish passage requirements of the Washington State Department of Fish and Wildlife.*

Other single event or continuous runoff models as described in Chapter 2 of this Volume may be used to determine design flows. In addition,

culverts shall not exceed the Headwater requirements as established below:

### Headwater

- For culverts 18-inch diameter or less, the maximum allowable headwater elevation for the 100-year, 24-hour design storm (measured from the inlet invert) shall not exceed 2 times the pipe diameter or arch-culvert-rise at design flow (See Section 4.4)
- For culverts larger than 18-inch diameter, the maximum allowable headwater elevation for the 100-year, 24-hour design storm (measured from the inlet invert) shall not exceed 1.5 times the pipe diameter or arch-culvert-rise at design flow.
- The maximum headwater elevation at the 100-year, 24-hour design flow shall be below any road or parking lot subgrade.

#### 4.6.2.2 Conveyance Capacity

The theoretical analysis of culvert capacity can be extremely complex because of the wide range of possible flow conditions that can occur due to various combinations of inlet and outlet submergence and flow regime within the culvert barrel. An exact analysis usually involves detailed backwater calculations, energy and momentum balance, and application of the results of hydraulic model studies.

However, simple procedures have been developed where the various flow conditions are classified and analyzed on the basis of a control section. A *control section* is a location where there is a unique relationship between the flow rate and the upstream water surface elevation. Many different flow conditions exist over time, but at any given time the flow is either governed by the culvert's inlet geometry (*inlet control*) or by a combination of inlet geometry, barrel characteristics, and tailwater elevation (*outlet control*). Figure 4-11 illustrates typical conditions of inlet and outlet control. The procedures presented in this section provide for the analysis of both inlet and outlet control conditions to determine which governs.

#### Inlet Control Analysis

Nomographs such as those provided in Figure 4-12 and Figure 4-13 can be used to determine the **inlet control headwater depth** at design flow for various types of culverts and inlet configurations. These nomographs were originally developed by the Bureau of Public Roads – now the Federal Highway Administration (FHWA) – based on their studies of culvert hydraulics. These and other nomographs can be found in the FHWA publication *Hydraulic Design of Highway Culverts, HDS No. #5 (Report No. FHWA-IP-85-15)*, September 1985; or the WSDOT *Hydraulic Manual*.

Also available in the FHWA publication are the design equations used to develop the inlet control nomographs. These equations are presented below.

For **unsubmerged** inlet conditions (defined by  $Q/AD^{0.5} \leq 3.5$ );

$$\text{Form 1*}: HW/D = H_c/D + K(Q/AD^{0.5})^M - 0.5S^{**} \quad (4-9)$$

$$\text{Form 2*}: HW/D = K(Q/AD^{0.5})^M \quad (4-10)$$

For **submerged** inlet conditions (defined by  $Q/AD^{0.5} \geq 4.0$ );

$$HW/D = c(Q/AD^{0.5})^2 + Y - 0.5S^{**} \quad (4-11)$$

where  $HW$  = headwater depth above inlet invert (ft)  
 $D$  = interior height of culvert barrel (ft)  
 $H_c$  = specific head (ft) at critical depth ( $d_c + V_c^2/2g$ )  
 $Q$  = flow (cfs)  
 $A$  = full cross-sectional area of culvert barrel (sf)  
 $S$  = culvert barrel slope (ft/ft)  
 $K, M, c, Y$  = constants from Table 4.8

The specified head  $H_c$  is determined by the following equation:

$$H_c = d_c + V_c^2/2g \quad (4-12)$$

where  $d_c$  = critical depth (ft); see Figure 4-16  
 $V_c$  = flow velocity at critical depth (fps)  
 $g$  = acceleration due to gravity (32.2 ft/sec<sup>2</sup>)

\* The appropriate equation form for various inlet types is specified in Table 4.8

\*\* For mitered inlets, use +0.7S instead of -0.5S.

*Note: Between the unsubmerged and submerged conditions, there is a transition zone ( $3.5 < Q/AD^{0.5} < 4.0$ ) for which there is only limited hydraulic study information. The transition zone is defined empirically by drawing a curve between and tangent to the curves defined by the unsubmerged and submerged equations. In most cases, the transition zone is short and the curve is easily constructed.*

### Outlet Control Analysis

Nomographs such as those provided in Figure 4-14 and Figure 4-15 can be used to determine the **outlet control headwater depth** at design flow for various types of culverts and inlets. Outlet control nomographs other than those provided can be found in *FHWA HDS No. 5* or the *WSDOT Hydraulic Manual*.

The outlet control headwater depth can also be determined using the simple Backwater Analysis method presented in Section 4.6 for analyzing pipe system capacity. This procedure is summarized as follows for culverts:

$$HW = H + TW - LS \quad (4-13)$$

where  $H = H_f + H_e + H_{ex}$   
 $H_f =$  friction loss (ft) =  $(V^2 n^2 L) / (2.22 R^{1.33})$   
*Note: If  $(H_f + TW - LS) < D$ , adjust  $H_f$  such that  $(H_f + TW - LS) = D$ . This will keep the analysis simple and still yield reasonable results (erring on the conservative side).*  
 $H_e =$  entrance head loss (ft) =  $K_e (V^2 / 2g)$   
 $H_{ex} =$  exit head loss (ft) =  $V^2 / 2g$   
 $TW =$  tailwater depth above invert of culvert outlet (ft)  
*Note: If  $TW < (D + d_c) / 2$ , set  $TW = (D + d_c) / 2$ . This will keep the analysis simple and still yield reasonable results.*  
 $L =$  length of culvert (ft)  
 $S =$  slope of culvert barrel (ft/ft)  
 $D =$  interior height of culvert barrel (ft)  
 $V =$  barrel velocity (fps)  
 $n =$  Manning's roughness coefficient from Table 4.5  
 $R =$  hydraulic radius (ft)  
 $K_e =$  entrance loss coefficient (from Table 4.9)  
 $G =$  acceleration due to gravity (32.2 ft/sec<sup>2</sup>)  
 $d_c =$  critical depth (ft); see Figure 4-16

*Note: The above procedure should not be used to develop stage/discharge curves for level pool routing purposes because its results are not precise for flow conditions where the hydraulic grade line falls significantly below the culvert crown (i.e., less than full flow conditions).*

### Inlets and Outlets

All inlets and outlets in or near roadway embankments must be flush with and conforming to the slope of the embankments.

- For culverts 18-inch diameter and larger, the embankment around the culvert inlet shall be protected from erosion by **rock lining or riprap** as specified in Chapter 4 of Volume 5., except the length shall extend at least 5 feet upstream of the culvert, and the height shall be at or above the design headwater elevation.

**Inlet structures**, such as concrete headwalls, may provide a more economical design by allowing the use of smaller entrance coefficients and, hence, smaller diameter culverts. When properly designed, they will also protect the embankment from erosion and eliminate the need for rock lining.

- In order to maintain the stability of roadway embankments, concrete headwalls, wingwalls, or tapered inlets and outlets may be required if **right-of-way or easement constraints** prohibit the culvert from extending to the toe of the embankment slopes. All inlet structures or headwalls installed in or near roadway embankments must be flush with and conforming to the slope of the embankment.
- **Debris barriers (trash racks)** are required on the inlets of all culverts that are over 60 feet in length and are 12 to 36 inches in diameter. This requirement also applies to the inlets of pipe systems. See Figures 4-10 for a debris barrier detail. Exceptions are culverts on Type 1 or 2 streams.
- For culverts 18-inch diameter and larger, the receiving channel of the outlet shall be protected from erosion by **rock lining** specified in Volume V – Table 4.5, except the height shall be one foot above maximum tailwater elevation or one foot above the crown, whichever is higher per Volume V - Figure 4.7.

*Note: Downsizing of downstream culverts within a closed system with culverts 18-inches in diameter or smaller will not be permitted.*

### 4.6.3 Open Channels

This section presents the methods, criteria, and details for hydraulic analysis and design of open channels. Open channels can be classified as either *natural* or *constructed*. Natural channels are generally referred to as streams, creeks, or swales, while constructed channels are most often called ditches, or simply channels. The City's Critical Areas Preservation Ordinance and Volume 1 of this manual should be reviewed for requirements related to streams.

#### Natural Channels

*Natural channels* are defined as those that have occurred naturally due to the flow of surface waters, or those that, although originally constructed by human activity, have taken on the appearance of a natural channel including a stable route and biological community. They may vary hydraulically along each channel reach and should be left in their natural condition, wherever feasible or required, in order to maintain natural hydrologic functions and wildlife habitat benefits from established vegetation.

#### Constructed Channels

*Constructed channels* are those constructed or maintained by human activity and include bank stabilization of natural channels. Constructed channels shall be either vegetation-lined, rock lined, or lined with appropriately bioengineered vegetation.

- **Vegetation-lined channels** are the most desirable of the constructed channels when properly designed and constructed. The vegetation

stabilizes the slopes of the channel, controls erosion of the channel surface, and removes pollutants. The channel storage, low velocities, water quality benefits, and greenbelt multiple-use benefits create significant advantages over other constructed channels. The presence of vegetation in channels creates turbulence, which results in loss of energy and increased flow retardation; therefore, the design engineer must consider sediment deposition and scour, as well as flow capacity, when designing the channel.

- **Rock-lined channels** are necessary where a vegetative lining will not provide adequate protection from erosive velocities they may be constructed with riprap, gabions, or slope mattress linings. The rock lining increases the turbulence, resulting in a loss of energy and increased flow retardation. Rock lining also permits a higher design velocity and therefore a steeper design slope than in grass-lined channels. Rock linings are also used for erosion control at culvert and storm drain outlets, sharp channel bends, channel confluences, and locally steepened channel sections.
- **Bioengineered vegetation lining** is a desirable alternative to the conventional methods of rock armoring. *Soil bioengineering* is a highly specialized science that uses living plants and plant parts to stabilize eroded or damaged land. Properly bioengineering systems are capable of providing a measure of immediate soil protection and mechanical reinforcement. As the plants grow they produce vegetative protective cover and a root reinforcing matrix in the soil mantle. This root reinforcement serves several purposes:
  - a. The developed anchor roots provide both shear and tensile strength to the soil, thereby providing protection from the frictional shear and tensile velocity components to the soil mantle during the time when flows are receding and pore pressure is high in the saturated bank.
  - b. The root mat provides a living filter in the soil mantle that allows for the natural release of water after the high flows have receded.
  - c. The combined root system exhibits active friction transfer along the length of the living roots. This consolidates soil particles in the bank and serves to protect the soil structure from collapsing and the stabilization measures from failing.

#### 4.6.3.1 Design Flows

Design flows for sizing or assessing the capacity of open channels shall be determined using the hydrologic analysis methods described in Section 4.4 – 4.6 of this chapter. Other single event or continuous runoff models as described in Chapter 2 of this Volume may be used to determine design flows. In addition, open channel shall meet the following:

- **Open channels** shall be designed to provide required conveyance capacity while minimizing erosion and allowing for aesthetics, habitat preservation, and enhancement.
- **An access easement for maintenance** is required along all constructed channels located on private property. Required easement widths and building setback lines vary with channel top width as shown in Table 4.12.
- **Channel cross-section geometry** shall be trapezoidal, triangular, parabolic, or segmental as shown in Figure 4-19 through Figure 4-21. Side slopes shall be no steeper than 3:1 for vegetation-lined channels and 2:1 for rock-lined channels.
- **Vegetation-lined channels** shall have bottom slope gradients of 6% or less and a maximum velocity at design flow of 5 fps (see Table 4.10).
- **Rock-lined channels or bank stabilization of natural channels** shall be used when design flow velocities exceed 5 feet per second. Rock stabilization shall be in accordance with Table 4.10 or stabilized with bioengineering methods as described above in “Constructed Channels.”

#### 4.6.3.2 Conveyance Capacity

There are three acceptable methods of analysis for sizing and analyzing the capacity of open channels:

- Manning’s equation for preliminary sizing
- Direct Step backwater method
- Standard Step backwater method

#### Manning’s Equation for Preliminary Sizing

Manning’s equation is used for preliminary sizing of open channel reaches of uniform cross section and slope (i.e., prismatic channels) and uniform roughness. This method assumes the flow depth (or normal depth) and flow velocity remain constant throughout the channel reach for a given flow.

The charts in Figure 4-19 and Figure 4-20 can be used to obtain graphic solutions of Manning’s equation for common ditch sections. For conditions outside the range of these charts or for more precise results, Manning’s equation can be solved directly from its classic forms shown in Equations (4-7) and (4-8).

Table 4-11 provides a reference for selecting the appropriate “*n*” values for open channels. A number of engineering reference books, such as *Open-Channel Hydraulics* by V.T. Chow, may also be used as guides to select “*n*” values. Figure 4-23 contains the geometric elements of



common channel sections useful in determining area  $A$ , wetted perimeter  $WP$ , and hydraulic radius ( $R=A/WP$ ).

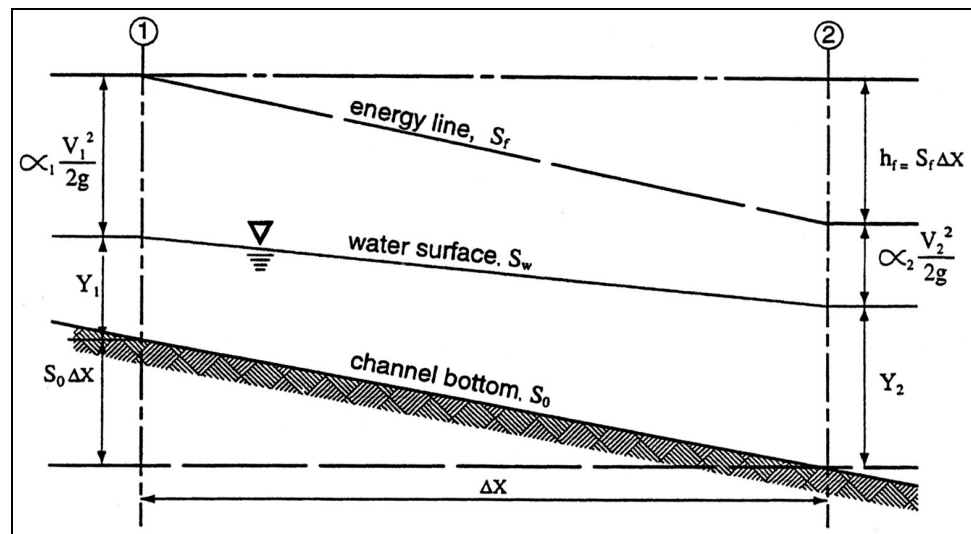
If flow restrictions occur which raise the water level above normal depth within a given channel reach, a *backwater condition* (or non-uniform flow) is said to exist. This condition can result from flow restrictions created by a downstream culvert, bridge, dam, pond, lake, etc., and even a downstream channel reach having a higher normal flow depth. If backwater conditions are found to exist for the design flow, a backwater profile must be computed to verify that the channel's capacity is still adequate as designed. The Direct Step or Standard Step backwater methods presented in this section can be used for this purpose.

**Direct Step Backwater Method**

The Direct Step Backwater Method can be used to compute backwater profiles on prismatic channel reaches (i.e. reaches having uniform cross section and slope) where a backwater condition or restriction to normal flow is known to exist. The method can be applied to a series of prismatic channel reaches in succession beginning at the downstream end of the channel and computing the profile upstream.

Calculating the coordinates of the water surface profile using the method is an iterative process achieved by choosing a range of flow depths, beginning at the downstream end, and proceeding incrementally up to the point of interest or to the point of normal flow depth. This is best accomplished by the use of a table (see Figure 4-22) or computer programs (as discussed in below).

To illustrate analysis of a single reach, consider the following:



Equating the total head at cross section 1 and 2, the following equation may be written:

$$S_0 \Delta x + y_1 + \alpha_1 \frac{V_1^2}{2g} = y_2 + \alpha_2 \frac{V_2^2}{2g} + S_f \Delta x \quad (4-14)$$

where,  $\Delta x$  = distance between cross sections (ft)  
 $y_1, y_2$  = depth of flow (ft at cross sections 1 and 2)  
 $V_1, V_2$  = velocity (fps) at cross sections 1 and 2  
 $\alpha_1, \alpha_2$  = energy coefficient at cross sections 1 and 2  
 $S_0$  = bottom slope (ft/ft)  
 $S_f$  = friction slope =  $(n_2 V_2) / 2.21 R^{1.33}$   
 $g$  = acceleration due to gravity, (32.2 ft/sec<sup>2</sup>)

If the specific energy  $E$  at any one cross section is defined as follows:

$$E = y + \alpha \frac{V^2}{2g} \quad (4-15)$$

and assuming  $\alpha = \alpha_1 = \alpha_2$  where  $\alpha$  is the energy coefficient which corrects for the non-uniform distribution of velocity over the channel cross section, Equations (4-14) and (4-15) can be combined and rearranged to solve for  $\Delta x$  as follows:

$$\Delta x = \frac{(E_2 - E_1)}{(S_0 - S_f)} = \frac{\Delta E}{(S_0 - S_f)} \quad (4-16)$$

Typically values of the energy coefficient  $\alpha$  are as follows:

Channels, regular section	1.15
Natural streams	1.3
Shallow vegetated flood fringes (includes channel)	1.75

For a given flow, channel slope, Manning's "n," and energy coefficient  $\alpha$ , together with a beginning water surface elevation  $y_2$ , the values of  $\Delta x$  may be calculated for arbitrarily chosen values of  $y_1$ . The coordinates defining the water surface profile are obtained from the cumulative sum of  $\Delta x$  and corresponding values of  $y$ .

The **normal flow depth**  $y_n$  should first be calculated from Manning's equation to establish the upper limit of the backwater effect.

### Standard Step Backwater Method

The Standard Step Backwater Method is a variation of the Direct Step Backwater Method and can be used to compute backwater profiles on both prismatic and non-prismatic channels. In this method, stations are established along the channel where cross section data is known or has

been determined through field survey. The computation is carried out in steps from station to station rather than throughout a given channel reach as is done in the Direct Step method. As a result, the analysis involves significantly more trial-and-error calculation in order to determine the flow depth at each station.

### Computer Applications

There are several different computer programs capable of the iterative calculations involved for these analyses. The project engineer is responsible for providing information describing how the program was used, assumptions the program makes and descriptions of all variables, columns, rows, summary tables, and graphs. The most current version of any software program shall be used for analysis. Tacoma may find specific programs not acceptable for use in design. Please check with Environmental Services, Science and Engineering Division, to confirm the applicability of a particular program prior to starting design.

### Riprap Design<sup>7</sup>

When riprap is set, stones are placed on the channel sides and bottom to protect the underlying material from being eroded. Proper riprap design requires the determination of the median size of stone, the thickness of the riprap layer, the gradation of stone sizes, and the selection of angular stones, which will interlock when placed. Research by the U.S. Army Corps of Engineers has provided criteria for selecting the **median stone weight,  $W_{50}$**  (Figure 4-17). If the riprap is to be used in a highly turbulent zone (such as at a culvert outfall, downstream of a stilling basin, at sharp changes in channel geometry, etc.), the median stone  $W_{50}$  should be increased from 200% to 600% depending on the severity of the locally high turbulence. The thickness of the riprap layer should generally be twice the **median stone diameter ( $D_{50}$ )** or at least that of the maximum stone. The riprap should have a reasonably well-graded assortment of stone sizes within the following gradation:

$$1.25 \leq D_{max}/D_{50} \leq 1.50$$

$$D_{15}/D_{50} = 0.50$$

$$D_{min}/D_{50} = 0.25$$

For a more detailed analysis and design procedure for riprap requiring water surface profiles and estimates of tractive force, refer to the paper by Maynard et al in *Journal of Hydraulic Engineering (A.S.C.E.)*, July 1989.

<sup>7</sup> From a paper prepared by M. Schaefer, Dam Safety Section, Washington State Department of Ecology.

## Riprap Filter Design

Riprap should be underlain by a sand and gravel filter (or filter fabric) to keep the fine materials in the underlying channel bed from being washed through the voids in the riprap. Likewise, the filter material must be selected so that it is not washed through the voids in the riprap. Adequate filters can usually be provided by a reasonably well graded sand and gravel material where:

$$D_{15} < 5d_{85}$$

The variable  $d_{85}$  refers to the sieve opening through which 85% of the material being protected will pass, and  $D_{15}$  has the same interpretation for the filter material. A filter material with a  $D_{50}$  of 0.5 mm will protect any finer material including clay. Where very large riprap is used, it is sometimes necessary to use two filter layers between the material being protected and the riprap.

### Example:

*What embedded riprap design should be used to protect a streambank at a level culvert outfall where the outfall velocities in the vicinity of the downstream toe are expected to be about 8 fps.*

From Figure 4-17,  $W_{50} = 6.5$  lbs, but since the downstream area below the outfall will be subjected to severe turbulence, increase  $W_{50}$  by 400% so that:

$$W_{50} = 26 \text{ lbs, } D_{50} = 8.0 \text{ inches}$$

The gradation of the riprap is shown in Figure 4-18, and the minimum thickness would be 1 foot (from Table 4.10); however, 16 inches to 24 inches of riprap thickness would provide some additional insurance that the riprap will function properly in this highly turbulent area.

Figure 4-18 shows that the gradation curve for ASTM C33, size number 57 coarse aggregate (used in concrete mixes), would meet the filter criteria. Applying the filter criteria to the coarse aggregate demonstrates that any underlying material whose gradation was coarser than that of a concrete sand would be protected.

For additional information and procedures for specifying filters for riprap, refer to *the Army Corps of Engineers Manual EM 1110-2-1601 (1970), Hydraulic Design of Flood Control Channels*, Paragraph 14, "Riprap Protection."

## **4.7 Outfalls and Pump Systems**

This section presents the methods, criteria and details for analysis and design of outfall systems and pump systems.

### **4.7.1 Outfall Systems**

Properly designed outfalls are critical to reducing the chance of adverse impacts as the result of concentrated discharges from pipe systems and culverts, both onsite and downstream. Outfall systems include rock splash pads, flow dispersal trenches, gabion or other energy dissipaters, and tightline systems. A tightline system is typically a continuous length of pipe used to convey flows down a steep or sensitive slope with appropriate energy dissipation at the discharge end.

General design criteria for both Outfall Features and Tightline Systems are presented in Volume V – Section 4.5.3

### **4.7.2 Pump Systems**

Pump systems are only allowed if applied for through the City's Exceptions process. Feasibility of all other methods of gravity conveyance, infiltration and dispersion shall first be investigated and demonstrated to be infeasible in the following order of preference:

1. Infiltration of surface water on-site (with City pre-approval)
2. Dispersion of surface water on site (with City pre-approval - meeting Volume I – Min. Req #4 and 5)
3. Gravity connection to the City storm drainage system.
4. Pumping to a gravity system

#### **Design Criteria**

If approved by the City Exceptions process (See Volume I, Section 3.7), the pump system must convey, at a minimum, the peak design flow for the 25-year 24-hour rainfall event. Pump capacity plus system storage or overflow, must convey or store the 100-year, 24-hour storm event.

#### **Pump Requirements**

If approved by the City Exemptions/Variance process, proposed pump systems must meet the following minimum requirements:

- The pump system shall be used to convey water from one location or elevation to another within the project site.
- The gravity-flow components of the drainage system to and from the pump system must be designed so that pump failure does not result in flooding of a building or emergency access or overflow to a location other than the natural discharge point for the project site.

- The pump system must have a dual pump (alternating) equipped with emergency back-up power OR a single pump may be provided without back-up power if the design provides the 100-year 24-hour storage volume.
- All pump systems must be equipped with an external pump failure and high water alarm system.
- The pump system will serve only one lot or business owner.
- The pump system must be privately owned and maintained.
- The pump system shall not be used to circumvent any other City of Tacoma drainage requirements. Construction and operation of the pump system shall not violate any City of Tacoma requirements.

### **Sump Pumps**

The above pump requirements do not apply to internal sump pumps. However, internal sump pumps **do require** a permit prior to connection to the City storm drainage system.

- Sump pumps should be sized to properly remove water from basements and crawl spaces.
- Sump pumps shall NOT be connected to the sanitary sewer system.
- Consult the pump manufacturer or an engineer for appropriate sizing of a sump pump.

## **4.8 Easements, Access, and Dedicated Tracts**

All publicly owned, manmade drainage facilities and conveyances and all natural channels on the project site used for conveyance of altered flows due to development (including swales, ditches, stream channels, lake shores, wetlands, potholes, estuaries, gullies, ravines, etc.) shall be located within easements or dedicated tracts as required by the City.

Easements shall contain the natural features and facilities and shall allow City access for purposes of inspection, maintenance, repair or replacement, flood control, water quality monitoring, and other activities permitted by law.

For easements dedicated to the City for the purpose of storm drainage, the following shall apply:

No permanent structures(s) shall be erected within the easement area(s) unless specifically approved in writing by the City of Tacoma Director of Public Works. Permanent structures shall mean any concrete foundation, concrete slab, wall, rockery, building, deck, overhanging structures, fill material, recreational sport courts, carports, portable sheds, private utilities, fences, or other site improvement that will unreasonably interfere with the

need to access or construct utilities in said easements(s). Permanent structures shall not mean improvements such as normal landscaping, asphalt paving, gravel, or other similar site improvements that do not prevent the access of men, materials, and machinery across, along, and within the said easement area. Land restoration by the City within the said easement area will be strictly limited to grass seed, grass sod, and/or asphalt replacement unless otherwise determined by the City of Tacoma.

*Note: Preliminary project planning should account for the potential loss of buildable area or the need to purchase more property as a result of drainage facilities and their required easements/tracts.*

#### **4.8.1 Stormwater Facilities**

##### **Public**

All drainage facilities such as detention ponds, infiltration systems, and water quality treatment vaults to be maintained by the City shall be located in separate tracts dedicated to the City. Stormwater facility tracts and easements shall include the setbacks required by Chapter 3 of the Volume and as indicated in Volume V.

##### **Private**

Privately owned facilities shall be located in separate tracts outside of dedicated public road right-of-way areas. **Private systems serving multiple lots require prior City approval.** For private systems serving multiple lots within residential developments or other developments, a separate covenant or other guarantee of proper maintenance and access shall be recorded on title and provided to the City.

#### **4.8.2 Conveyance Systems**

##### **Public**

All publicly and privately maintained conveyance systems shall be located in dedicated tracts, drainage easements, or public rights-of-way. **Public storm drainage easements shall be a minimum of 20 feet in width** Refer to Table 4.3 for minimum widths for public facilities. Consult Section 4.6 of this volume for pipe alignment requirements.

In addition, all pipes and channels must be located within the easement so that each pipe face or top edge of channel is no closer than 5 feet from its adjacent easement boundary. Pipes greater than 5 feet in diameter and channels with top widths greater than 5 feet shall be placed in easements adjusted accordingly, so as to meet the required dimensions from the easement boundaries.

*Note: The depth or proximity of steep slopes to the public system may necessitate a larger easement requirement for future excavation and maintenance purposes.*

**Easements as shown in Table 4.12 are minimums for public drainage facilities. Consult with Table 4.13 for appropriate widths based on depth of pipe.**

### **Private**

All privately maintained conveyance systems serving multiple lots/owners shall be located in dedicated tracts, drainage easements, or private roadways. Any new conveyance system located on private property designed to convey drainage from other private properties must be located in a private drainage easement granted to the contributors of stormwater to said systems. The easement shall permit access for maintenance or replacement in the case of failure.

Unless prohibited by topography or existing site conditions, new conveyance system alignments, on private property, must be located in drainage easements that are adjacent and parallel to property lines. **Private storm drainage easements shall be a minimum of 10 feet in width.** *Note: The depth or proximity to steep slopes of a private system may necessitate a larger easement for future excavation and maintenance purposes. Typically this requires a 1:1 slope from the bottom of the trench.*

**Exception:** Streams and natural drainage channels will not be relocated strictly to meet this requirement.

In addition, all pipes and channels must be located within the easement so that each pipe face or top edge of channel is no closer than 5 feet from its adjacent easement boundary. Pipes greater than 5 feet in diameter and channels with top widths greater than 5 feet shall be placed in easements adjusted accordingly, so as to meet the required dimensions from the easement boundaries.

**Easements as shown in Table 4.12 are minimums for drainage facilities. Consult with Table 4.13 for appropriate widths based on depth of pipe.**

### **Maintenance Access**

A minimum 15-foot wide access easement shall be provided to drainage facilities from a public street or right-of-way. Access easements shall be surfaced with a minimum 12-foot width of crushed rock, or other approved surface to allow year-round equipment access to the facility.

Maintenance access must be provided for all manholes, catch basins, vaults, or other underground drainage facilities operated by the City. Maintenance shall be through an access easement or dedicated tract. These must include a constructed access road per the requirements of Section 3.3.1 of this Volume.



**Table 4.1 – Percentage Impervious for Modeling Fully Developed Conditions**

Land Use Description*	% Impervious
Commercial/Industrial	85
Residential	65

\* For the land use descriptions, roads are included in the percentage impervious.

**Table 4.2 – Coefficients for the Rational Method**

Design Storm Frequency	$P_R$ (inches)	$a_R$	$b_R$
2 years	2.0	1.58	0.58
5 years	2.5	2.33	0.63
10 years	3.0	2.44	0.64
25 years	3.5	2.66	0.65
50 years	3.5	2.75	0.65
100 years	4.1	2.61	0.63

**Table 4.3**

**Runoff Coefficients - "C" Values for the Rational Method\***  
 \*(For use only in determining peak design flow for analyzing and sizing pipes, culverts or channels.)

GENERAL LAND COVERS			
LAND COVER	$\underline{C}$	LAND COVER	$\underline{C}$
Dense forest	0.10	Playgrounds	0.30
Light forest	0.15	Gravel areas	0.80
Pasture	0.20	Pavement and roofs	0.90
Lawns	0.25	Open water (pond, lakes, wetlands)	1.00
SINGLE FAMILY RESIDENTIAL AREAS [Density is in dwelling units per gross acreage (DU/GA)]			
LAND COVER DENSITY	$\underline{C}$	LAND COVER DENSITY	$\underline{C}$
0.20 DU/GA (1 unit per 5 ac.)	0.17	3.00 DU/GA	0.42
0.40 DU/GA (1 unit per 2.5 ac.)	0.20	3.50 DU/GA	0.45
0.80 DU/GA (1 unit per 1.25 ac.)	0.27	4.00 DU/GA	0.48
1.00 DU/GA	0.30	4.50 DU/GA	0.51
1.50 DU/GA	0.33	5.00 DU/GA	0.54
2.00 DU/GA	0.36	5.50 DU/GA	0.57
2.50 DU/GA	0.39	6.00 DU/GA	0.60

**Table 4.4 –  $k_R$  Values for Derivation of  $T_t$**

Land Cover Category	$k_R$
Forest with heavy ground litter and meadow	2.5
Fallow or minimum tillage cultivation	4.7
Short grass pasture and lawns	7.0
Nearly bare ground	10.1
Grasses waterway	15.0
Paved area (sheet flow) and shallow gutter flow	20.0

**Table 4.5 - Manning's "n" Values for Pipes**

Type of Pipe Material	Analysis Method	
	Backwater Flow	Manning's Equation Flow
A. Concrete pipe and CPEP-smooth interior pipe	0.012	0.014
B. Annular Corrugated Metal Pipe or Pipe Arch:		
1. 2-2/3" x 1/2" corrugation (riveted)		
a. plain or fully coated	0.024	0.028
b. paved invert (40% of circumference paved):		
(1) flow full depth	0.018	0.021
(2) flow 0.8 depth	0.016	0.018
(3) flow 0.6 depth	0.013	0.015
c. treatment	0.013	0.015
2. 3" x 1" corrugation	0.027	0.031
3.6" x 2" corrugation (field bolted)	0.030	0.035
C. Helical 2-2/3" x 1/2" corrugation and CPEP-single wall	0.024	0.028
D. Spiral rib metal pipe and PVC pipe	0.011	0.013
E. Ductile iron pipe cement lined	0.012	0.014
F. High density polyethylene pipe (butt fused only)	0.009	0.009

**Table 4.6 - Maximum Pipe Slopes, Velocities and Anchor Requirements**

Pipe Material	Pipe Slope Above Which Pipe Anchors Required and Minimum Anchor Spacing	Max. Slope Allowed	Max. Velocity @ Full Flow
*Spiral Rib, *PVC, CPEP-singlewall	20% (1 anchor per 100 L.F. of pipe)	30%***	30 fps
*Concrete or *CPEP-smooth interior	10% (1 anchor per 50 L.F. of pipe)	20%***	30 fps
Ductile Iron	40% (1 anchor per pipe section)	None	None
**HDPP	50% (1 anchor per 100 L.F. of pipe - cross slope installations only)	None	None
<p>* Not allowed in landslide hazard areas.  ** Butt-fused pipe joints required. Above-ground installation is required on slopes greater than 40% to minimize disturbance to steep slopes.  *** Maximum slope of 200% allowed for these pipe materials with no joints (one section) with structures at each end and property grouted.</p> <p>KEY: PVC = Polyvinyl chloride pipe  CPEP = Corrugated high density polyethylene pipe  HDPP = High density polyethylene pipe</p>			

**Table 4.7 - Allowable Structures and Pipe Sizes**

Catch Basin Type <sup>(1)</sup>	Maximum Inside Pipe Diameter	
	CMP, Spiral Rib, CPEP (single wall), HDPP, Ductile Iron, PVC <sup>(2)</sup> (Inches)	Concrete, CPEP (smooth interior), (Inches)
Inlet <sup>(4)</sup>	12	12
Type 1 <sup>(3)</sup>	15	12
Type IL <sup>(3)</sup>	21	18
Type 2 - 48-inch dia.	30	24
Type 2 - 54-inch dia.	36	30
Type 2 - 60-inch dia.	42	36
Type 2 - 72-inch dia.	54	42
Type 2 - 96-inch dia.	72	60
<p>(1) Catch basins (including manhole steps, ladder, and handholds) shall conform to the W.S.D.O.T. Standard Plans or an approved equal based upon submittal for approval.  (2) Maintain the minimum sidewall thickness per this Section.  (3) Maximum 5 vertical feet allowed between grate and invert elevation.  (4) Normally allowed only for use in privately maintained drainage systems and must discharge to a catch basin immediately downstream.</p>		

NOTE: The proponent shall check with the City to determine the allowable pipe materials.

**Table 4.8 – Constants for Inlet Control Equations\***

Shape and Material	Inlet Edge Description	Unsubmerged			Submerged	
		Equation Form	<i>K</i>	<i>M</i>	<i>c</i>	<i>Y</i>
Circular Concrete	Square edge with headwall	1	0.0098	2.0	0.0398	0.67
	Groove end with headwall		0.0078	2.0	0.0292	0.74
	Groove end projecting		0.0045	2.0	0.0317	0.69
Circular CMP	Headwall	1	0.0078	2.0	0.0379	0.69
	Mitered to slope		0.0210	1.33	0.0463	0.75
	Projecting		0.0340	1.50	0.0553	0.54
Rectangular Box	30° to 75° wingwall flares	1	0.026	1.0	0.0385	0.81
	90° and 15° wingwall flares		0.061	0.75	0.0400	0.80
	0° wingwall flares		0.061	0.75	0.0423	0.82
CM Boxes	90° headwall	1	0.0083	2.0	0.0379	0.69
	Thick wall projecting		0.0145	1.75	0.0419	0.64
	Thin wall projecting		0.0340	1.5	0.0496	0.57
Arch CMP	90° headwall	1	0.0083	2.0	0.0496	0.57
	Mitered to slope		0.0300	1.0	0.0463	0.75
	Projecting		0.0340	1.5	0.0496	0.53
Bottomless Arch CMP	90° headwall	1	0.0083	2.0	0.0379	0.69
	Mitered to slope		0.0300	2.0	0.0463	0.75
	Thin wall projecting		0.0340	1.5	0.0496	0.57
Circular with Tapered Inlet	Smooth tapered inlet throat	2	0.534	0.333	0.0196	0.89
	Rough tapered inlet throat		0.519	0.64	0.0289	0.90

\*Source: FHWA HDS No. 5

**Table 4.9 – Entrance Loss Coefficients**

Type of Structure and Design Entrance	Coefficient, K <sub>c</sub>
<u>Pipe, Concrete, PVC, Spiral Rib, DI, and LCPE</u>	
Projecting from fill, socket (bell) end	0.2
Projecting from fill, square cut end	0.5
Headwall, headwall and wingwalls	
Socket end of pipe (groove-end)	0.2
Square-edge	0.5
Rounded (radius = 1/12D)	0.2
Mitered to conform to fill slope	0.7
End section conforming to fill slope*	0.5
Beveled edges, 33.7° or 45° bevels	0.2
Side- or slope-tapered inlet	0.2
<u>Pipe, Pipe-Arch, Corrugated Metal and Other Non-Concrete or D.I.</u>	
Projecting from fill (no headwall)	0.9
Headwall, or headwall and wingwalls (square-edge)	0.5
Mitered to conform to fill slope (paved or unpaved slope)	0.7
End section conforming to fill slope*	0.5
Beveled edges, 33.7° or 45° bevels	0.2
Side- or slope-tapered inlet	0.2
<u>Box, Reinforced Concrete</u>	
Headwall parallel to embankment (no wingwalls)	
Square-edged on 3 edges	0.5
Rounded on 3 edges to radius of 1/12 barrel dimension or beveled edges on 3 sides	0.2
Wingwalls at 30° to 75° to barrel	
Square-edged at crown	0.4
Crown edge rounded to radius of 1/12 barrel dimension or beveled top edge	0.2
Wingwall at 10° to 25° to barrel	
Square-edged at crown	0.5
Wingwalls parallel (extension of sides)	
Square-edged at crown	0.7
Side- or slope-tapered inlet	0.2

Note: “End section conforming to fill slope” are the sections commonly available from manufacturers. From limited hydraulic tests they are equivalent in operation to a headwall in both **inlet and outlet control**. Some end sections incorporating a **closed taper** in their design have a superior hydraulic performance.

**Table 4.10 – Channel Protection**

Velocity at Design Flow (fps)		REQUIRED PROTECTION		
Greater than	Less than or equal to	Type of Protection	Thickness	Minimum Height Above Design Water Surface
0	5	Grass lining or bioengineered lining	N/A	0.5 foot
5	8	Rock lining <sup>(1)</sup> or bioengineered lining	1 foot	1 foot
8	12	Riprap <sup>(2)</sup>	2 feet	2 feet
12	20	Slope mattress gabion, etc.	Varies	2 feet
<p><sup>(1)</sup> Rock Lining shall be reasonable well graded as follows:  Maximum stone size: 12 inches  Median stone size: 8 inches  Minimum stone size: 2 inches</p> <p><sup>(2)</sup> Riprap shall be reasonably well graded as follows:  Maximum stone size: 24 inches  Median stone size: 16 inches  Minimum stone size: 4 inches</p> <p><i>Note: Riprap sizing is governed by side slopes on channel, assumed to be approximately 3:1.</i></p>				

**Table 4.11 – Values of the Roughness Coefficient, “n”**

Type of Channel and Description	Manning's "n"* (Normal)	Type of Channel and Description	Manning's "n"* (Normal)
<b>I. Constructed Channels</b>			
a. Earth, straight and uniform		7. Sluggish reaches, weedy deep pools	0.070
1. Clean, recently completed	0.018	6. Very weedy reaches, deep pools, or floodways with heavy stand of timber and underbrush	0.100
2. Gravel, uniform section, clean	0.025		
3. With short grass, few weeds	0.027		
b. Earth, winding and sluggish		b. Mountain streams, no vegetation in channel, banks usually steep, trees and brush along banks submerged at high stages	
1. No vegetation	0.025	1. Bottom: gravel, cobbles, and few boulders	0.040
2. Grass, some weeds	0.030	2. Bottom: cobbles with large boulders	0.050
3. Dense weeds or aquatic plants in deep channels	0.035		
4. Earth bottom and rubble sides	0.030		
5. Stony bottom and weedy banks	0.035	II-2 Floodplains	
6. Cobble bottom and clean sides	0.040	a. Pasture, no brush	
c. Rock lined		1. Short grass	0.030
1. Smooth and uniform	0.035	2. High grass	0.035
2. Jagged and irregular	0.040	b. Cultivated areas	
d. Channels not maintained, weeds and brush uncut		1. No crop	0.030
1. Dense weeds, high as flow depth	0.080	2. Mature row crops	0.035
2. Clean bottom, brush on sides	0.050	3. Mature field crops	0.040
3. Same as #2, highest stage of flow	0.070	c. Brush	
4. Dense brush, high stage	0.100	1. Scattered brush, heavy weeds	0.050
		2. Light brush and trees	0.060
		3. Medium to dense brush	0.070
		4. Heavy, dense brush	0.100
		d. Trees	0.150
		1. Dense willows, straight	0.040
		2. Cleared land with tree stumps, no sprouts	0.060
		3. Same as #2, but with heavy growth of sprouts	0.100
		4. Heavy strand of timber, a few down trees, little undergrowth, flood stage below branches	0.120
		5. Same as #4, but with flood stage reaching branches	
<b>II. Natural Streams</b>			
II-1 Minor streams (top width at flood stage < 100 ft.)			
a. Streams on plain			
1. Clean, straight, full stage no rifts or deep pools	0.030		
2. Same as #1, but more stones and weeds	0.035		
3. Clean, winding, some pools and shoals	0.040		
4. Same as #3, but some weeds	0.040		
5. Same as #4, but more stones	0.050		
* Note: These “n” values are “normal” values for use in analysis of channels. For conservative design for channel capacity, the maximum values listed in other references should be considered. For channel bank stability, the minimum values should be considered.			

**Table 4.12 – Minimum Easement Widths for Conveyance Systems  
For Access, Inspection and Maintenance**

<u>CONVEYANCE WIDTH</u>	<u>EASEMENT WIDTH</u>
Channels ≤ 30 feet wide	Channel Width + 15 feet from top, one side
Channels > 30 feet wide	Channel Width + 15 feet from top, both sides
Pipes/Outfalls ≤ 36 inches	20 feet centered on pipe
Pipes/Outfalls ≤ 60 inches	15 feet centered on pipe*
Pipes/Outfalls > 60 inches	30 feet centered on pipe*

\* May be greater, depending on depth and number of pipes in easement.

**Table 4.13 – Additional Storm Drain Easement Widths**

<u>INVERT DEPTH</u>	<u>WIDTH</u>
< 10'	20'
10' - 15'	25'
15' - 20'	30'
> 20'	40'

Greater width may be required for large diameter pipe or unfavorable site conditions.  
Pipe shall be installed in center of easement.

If two pipes are to be installed in an easement, add 10 feet to the easement widths listed above. Use the deeper of the two pipes in selecting the easement width from this table. Install pipes with 10 feet of horizontal clearance between them.



FIGURE 4-1 – NOMOGRAPH FOR SIZING CIRCULAR DRAINS FLOWING FULL

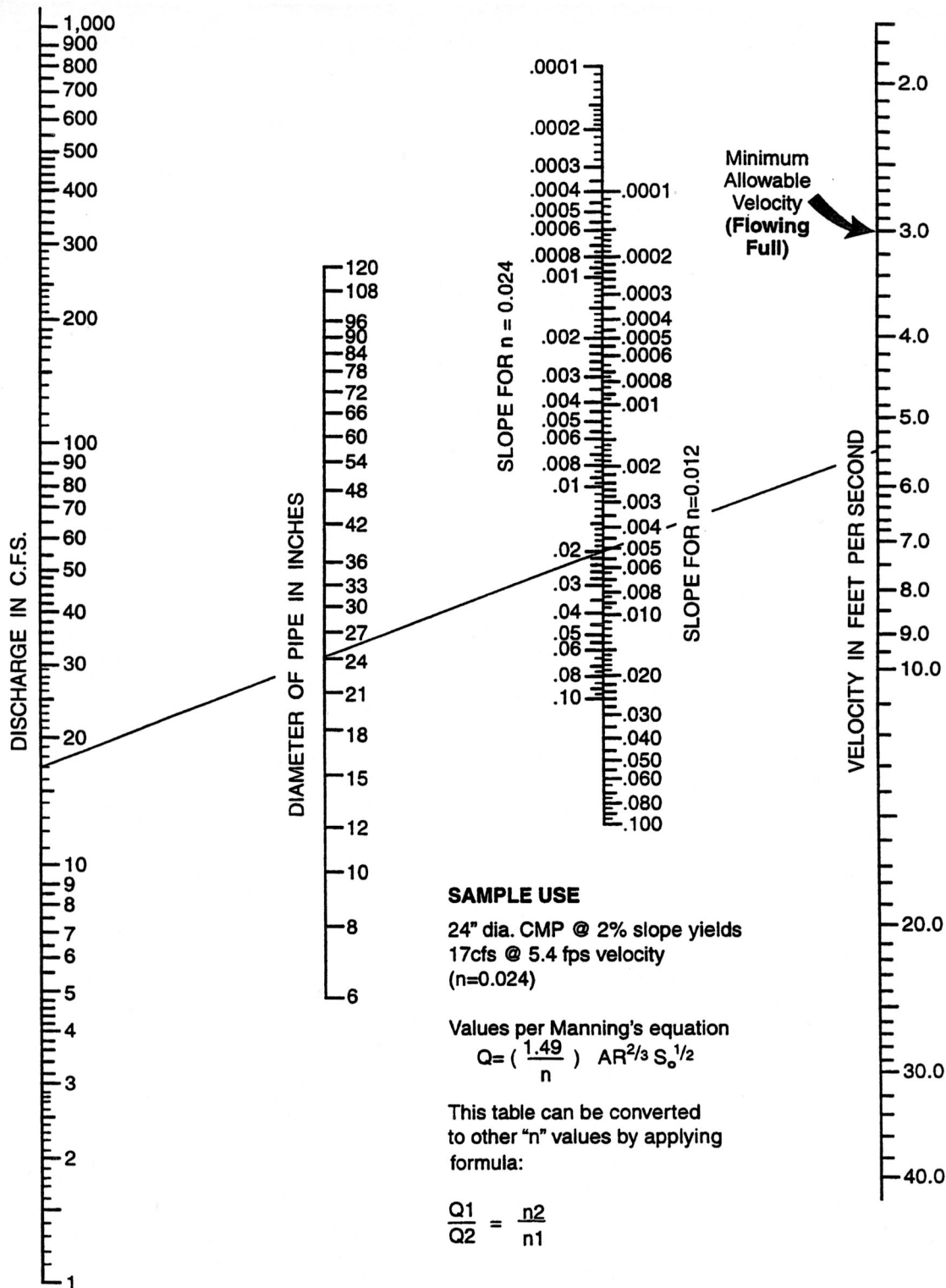


FIGURE 4-2 – CIRCULAR CHANNEL RATIOS

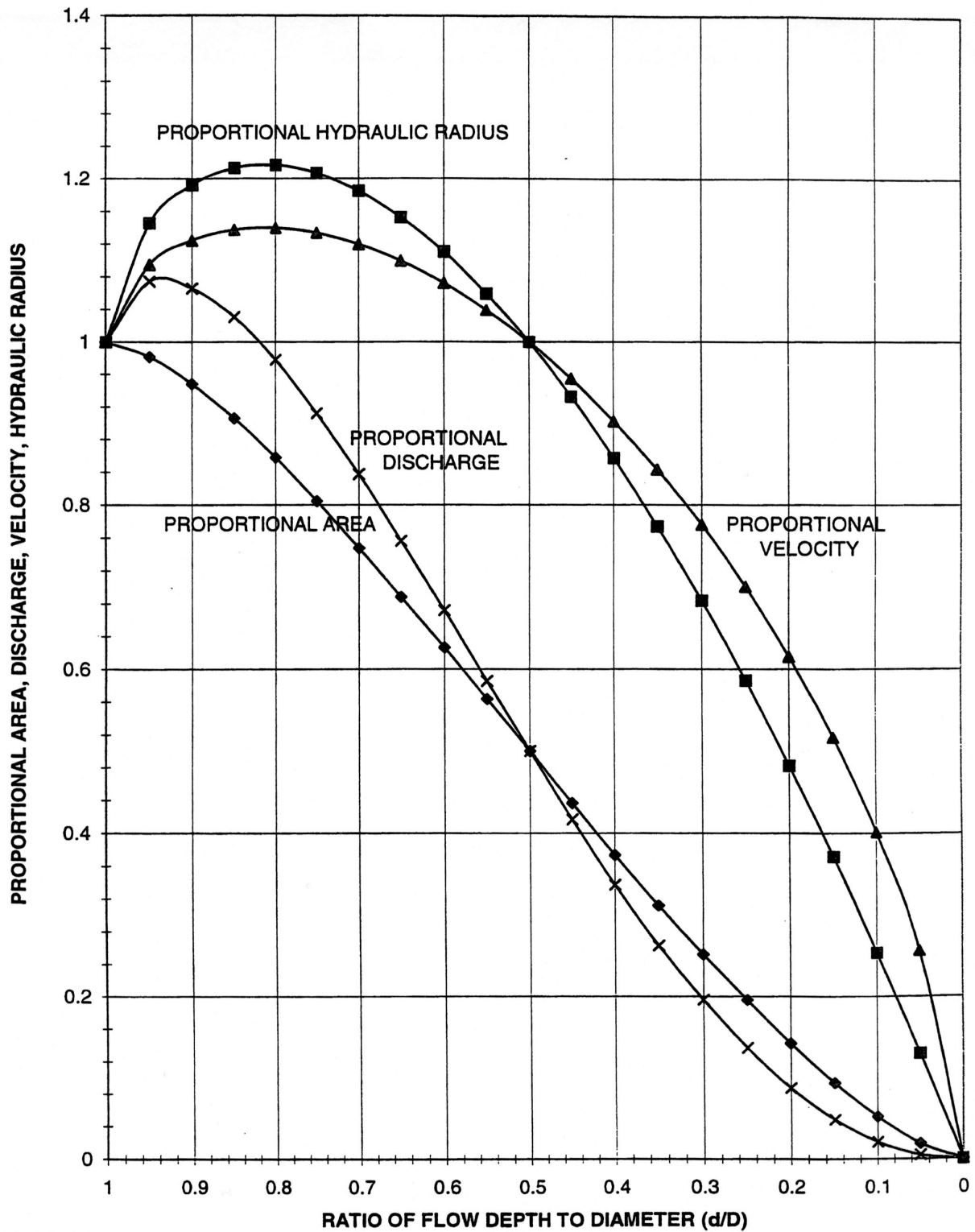


FIGURE 4-3 - BACKWATER CALCULATION SHEET

Pipe Segment CB to CB	(1) Q (cfs)	(2) Length (ft)	(3) Pipe Size	(4) "n" Value	(5) Outlet Elev (ft)	(6) Inlet Elev (ft)	(7) Barrel Area (sq. ft.)	(8) Barrel Vel (fps)	(9) Barrel Vel Head (ft)	(10) TW Elev (ft)	(11) Friction Loss (ft)	(12) Entr HGL Elev (ft)	(13) Entr Head Loss (ft)	(14) Exit Head Loss (ft)	(15) Outlet Cntrl Elev (ft)	(16) Inlet Cntrl Elev (ft)	(17) Appr Vel Head (ft)	(18) Bend Head Loss (ft)	(19) Junc Head Loss (ft)	(20) HW Elev (ft)		

## FIGURE 4-4 – BACKWATER CALCULATION SHEET NOTES

- Column (1) - Design flow to be conveyed by pipe segment.
- Column (2) - Length of pipe segment.
- Column (3) - Pipe Size; indicate pipe diameter or span x rise.
- Column (4) - Manning's "n" value.
- Column (5) - Outlet Elevation of pipe segment.
- Column (6) - Inlet Elevation of pipe segment.
- Column (7) - Barrel Area; this is the full cross-sectional area of the pipe.
- Column (8) - Barrel Velocity; this is the full velocity in the pipe as determined by:  

$$V = Q/A \text{ or } \text{Col.}(8) = \text{Col.}(1) / \text{Col.}(7)$$
- Column (9) - Barrel Velocity Head =  $V^2/2g$  or  $(\text{Col.}(8))^2/2g$   
 where  $g = 32.2 \text{ ft/sec}^2$  (acceleration due to gravity)
- Column (10) - Tailwater (TW) Elevation; this is the water surface elevation at the outlet of the pipe segment. If the pipe's outlet is not submerged by the TW and the TW depth is less than  $(D+d_c)/2$ , set TW equal to  $(D+d_c)/2$  to keep the analysis simple and still obtain reasonable results ( $D$  = pipe barrel height and  $d_c$  = critical depth, both in feet. See Figure 4.3.1.F (p. 4-47) for determination of  $d_c$ ).
- Column (11) - Friction Loss =  $S_f \times L$  [or  $S_f \times \text{Col.}(2)$ ]  
 where  $S_f$  is the friction slope or head loss per linear foot of pipe as determined by Manning's equation expressed in the form:  

$$S_f = (\pi V)^2/2.22 R^{1.33}$$
- Column (12) - Hydraulic Grade Line (HGL) Elevation just inside the entrance of the pipe barrel; this is determined by adding the friction loss to the TW elevation:  

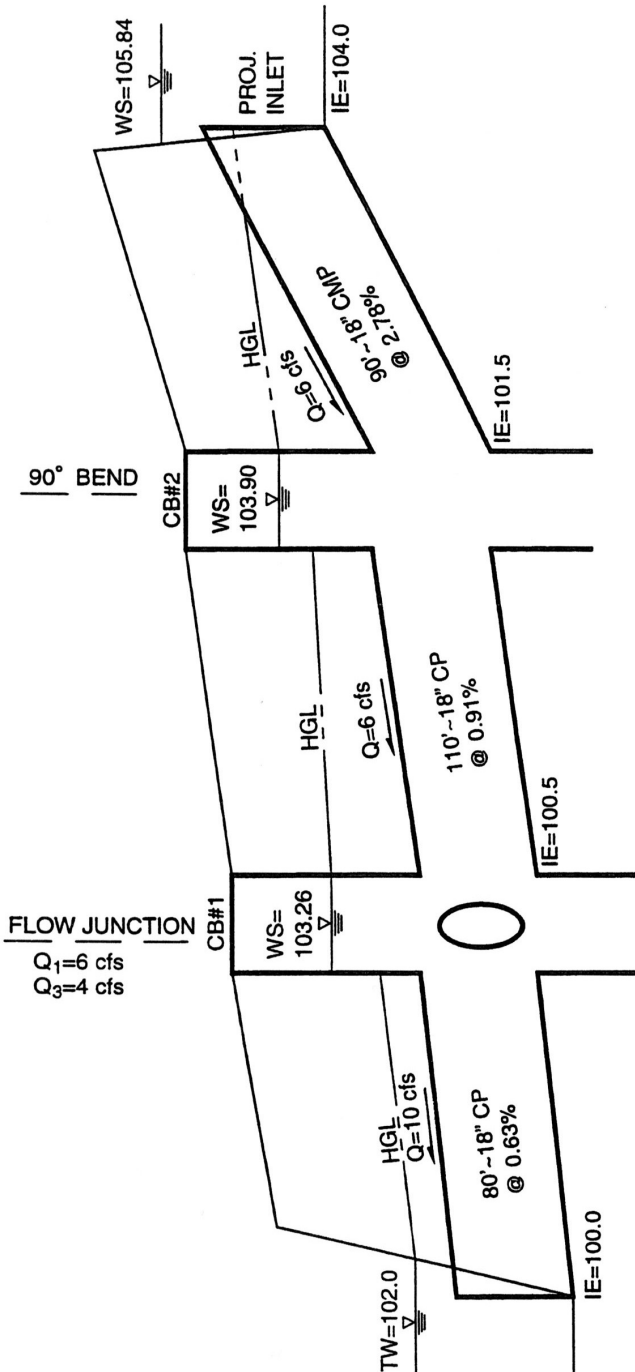
$$\text{Col.}(12) = \text{Col.}(11) + \text{Col.}(10)$$
  
 If this elevation falls below the pipe's inlet crown, it no longer represents the true HGL when computed in this manner. The true HGL will fall somewhere between the pipe's crown and either normal flow depth or critical flow depth, whichever is greater. To keep the analysis simple and still obtain reasonable results (i.e., erring on the conservative side), set the HGL elevation equal to the crown elevation.
- Column (13) - Entrance Head Loss =  $K_e \times V^2/2g$  [or  $K_e \times \text{Col.}(9)$ ]  
 where  $K_e$  = Entrance Loss Coefficient (from Table 4.3.1.B, p. 4-40). This is the head lost due to flow contractions at the pipe entrance.
- Column (14) - Exit Head Loss =  $1.0 \times V^2/2g$  or  $1.0 \times \text{Col.}(9)$   
 This is the velocity head lost or transferred downstream.
- Column (15) - Outlet Control Elevation =  $\text{Col.}(12) + \text{Col.}(13) + \text{Col.}(14)$   
 This is the maximum headwater elevation assuming the pipe's barrel and inlet/outlet characteristics are controlling capacity. It does not include structure losses or approach velocity considerations.
- Column (16) - Inlet Control Elevation (see Section 4.3.1.2, page 4-37, for computation of inlet control on culverts); this is the maximum headwater elevation assuming the pipe's inlet is controlling capacity. It does not include structure losses or approach velocity considerations.
- Column (17) - Approach Velocity Head; this is the amount of head/energy being supplied by the discharge from an upstream pipe or channel section, which serves to reduce the headwater elevation. If the discharge is from a pipe, the approach velocity head is equal to the barrel velocity head computed for the upstream pipe. If the upstream pipe outlet is significantly higher in elevation (as in a drop manhole) or lower in elevation such that its discharge energy would be dissipated, an approach velocity head of zero should be assumed.
- Column (18) - Bend Head Loss =  $K_b \times V^2/2g$  [or  $K_b \times \text{Col.}(17)$ ]  
 where  $K_b$  = Bend Loss Coefficient (from Figure 4.2.1.K, p. 4-25). This is the loss of head/energy required to change direction of flow in an access structure.
- Column (19) - Junction Head Loss. This is the loss in head/energy which results from the turbulence created when two or more streams are merged into one within the access structure. Figure 4.2.1.L (p. 4-26) can be used to determine this loss, or it can be computed using the following equations derived from Figure 4.2.1.L:  

$$\text{Junction Head Loss} = K_j \times V^2/2g \text{ [or } K_j \times \text{Col.}(17)]$$
  
 where  $K_j$  is the Junction Loss Coefficient determined by:  

$$K_j = (Q_2/Q_1)/(1.18 + 0.63(Q_2/Q_1))$$
- Column (20) - Headwater (HW) Elevation; this is determined by combining the energy heads in Columns 17, 18, and 19 with the highest control elevation in either Column 15 or 16, as follows:  

$$\text{Col.}(20) = \text{Col.}(15 \text{ or } 16) - \text{Col.}(17) + \text{Col.}(18) + \text{Col.}(19)$$

FIGURE 4-5 – BACKWATER PIPE CALCULATION EXAMPLE



**BACKWATER CALCULATION SHEET**

Pipe Segment CB to CB	(1) Q (cfs)	(2) Length (ft)	(3) Pipe Size	(4) "n" Value	(5) Outlet Elev (ft)	(6) Inlet Elev (ft)	(7) Barrel Area (sqft)	(8) Barrel Vel (fps)	(9) Barrel Head Vel (ft)	(10) TW Elev (ft)	(11) Fric- tion Loss (ft)	(12) Entr HGL Elev (ft)	(13) Entr Head Loss (ft)	(14) Exit Head Loss (ft)	Select the greater elevation				(20) HW Elev (ft)	
															(15) Outlet Elev (ft)	(16) Inlet Contr Elev (ft)	(17) Appr Head Loss (ft)	(18) Bend Head Loss (ft)		(19) Junc Head Loss (ft)
Outfall	10	80	18"	0.012	100.00	100.50	1.77	5.65	0.50	102.00	0.62	102.62	0.25	0.50	103.37	102.75	-0.18	0.002	0.07	103.26
1	6	110	18"	0.012	100.50	101.50	1.77	3.39	0.18	103.26	0.31	103.57	0.09	0.18	103.84	102.95	-0.18	0.24	0.0	103.90
2	6	90	18"	0.024	101.50	104.00	1.77	3.39	0.18	103.90	1.00	105.5	0.16	0.18	105.84	105.80	-0.0	0.0	0.0	105.84

FIGURE 4-6 – JUNCTION HEAD LOSS IN STRUCTURES

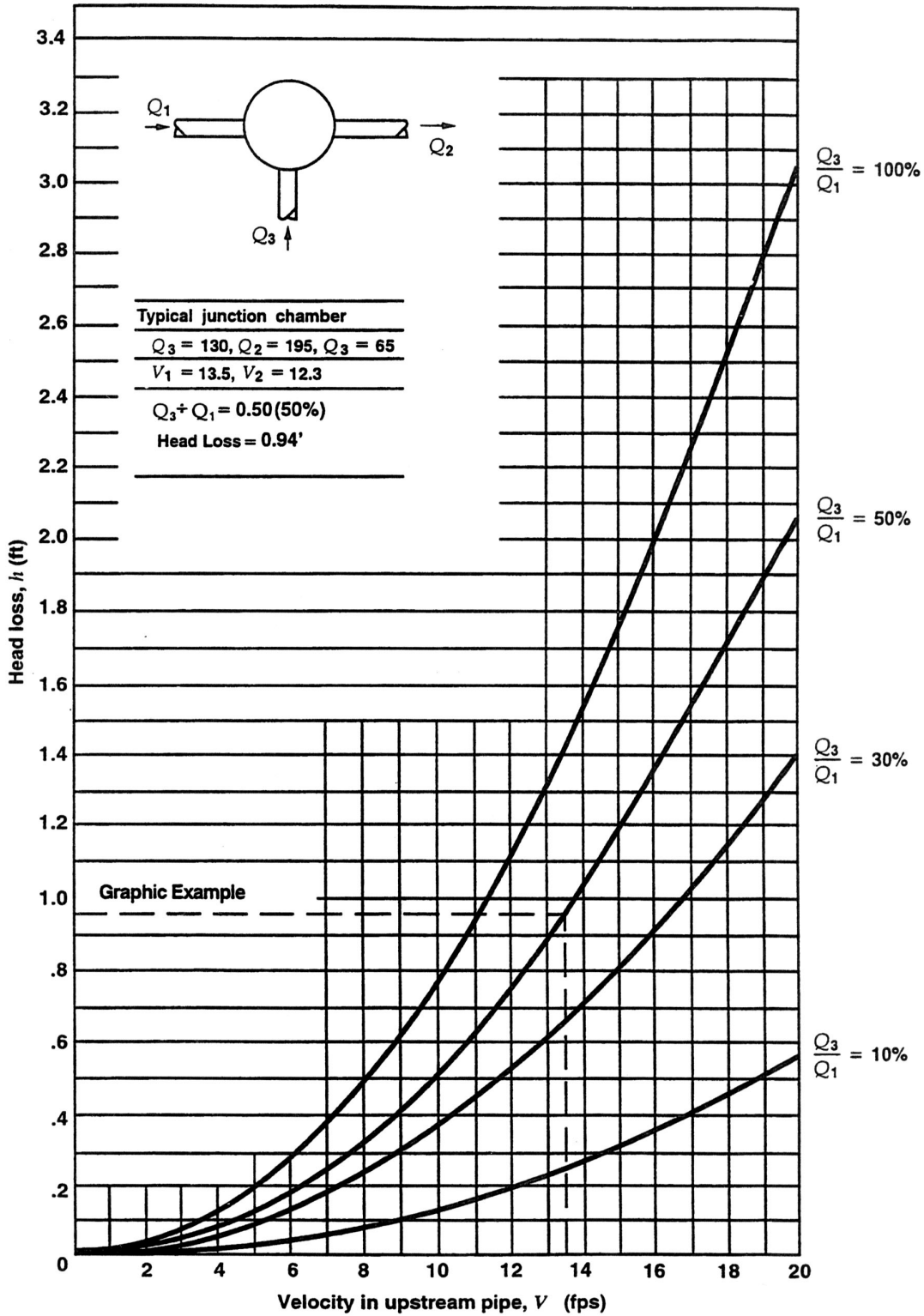
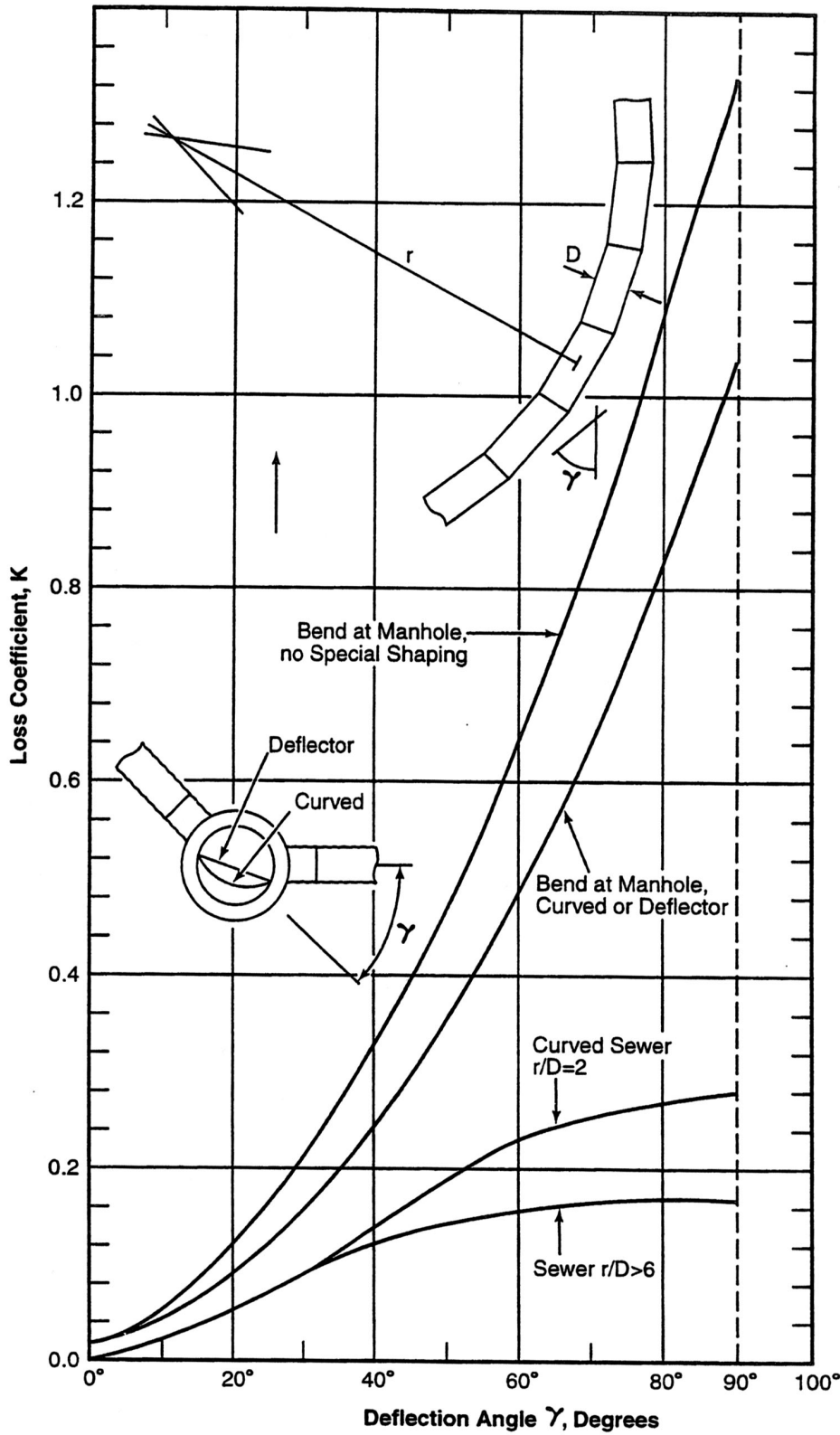


FIGURE 4-7 – BEND HEAD LOSSES IN STRUCTURES

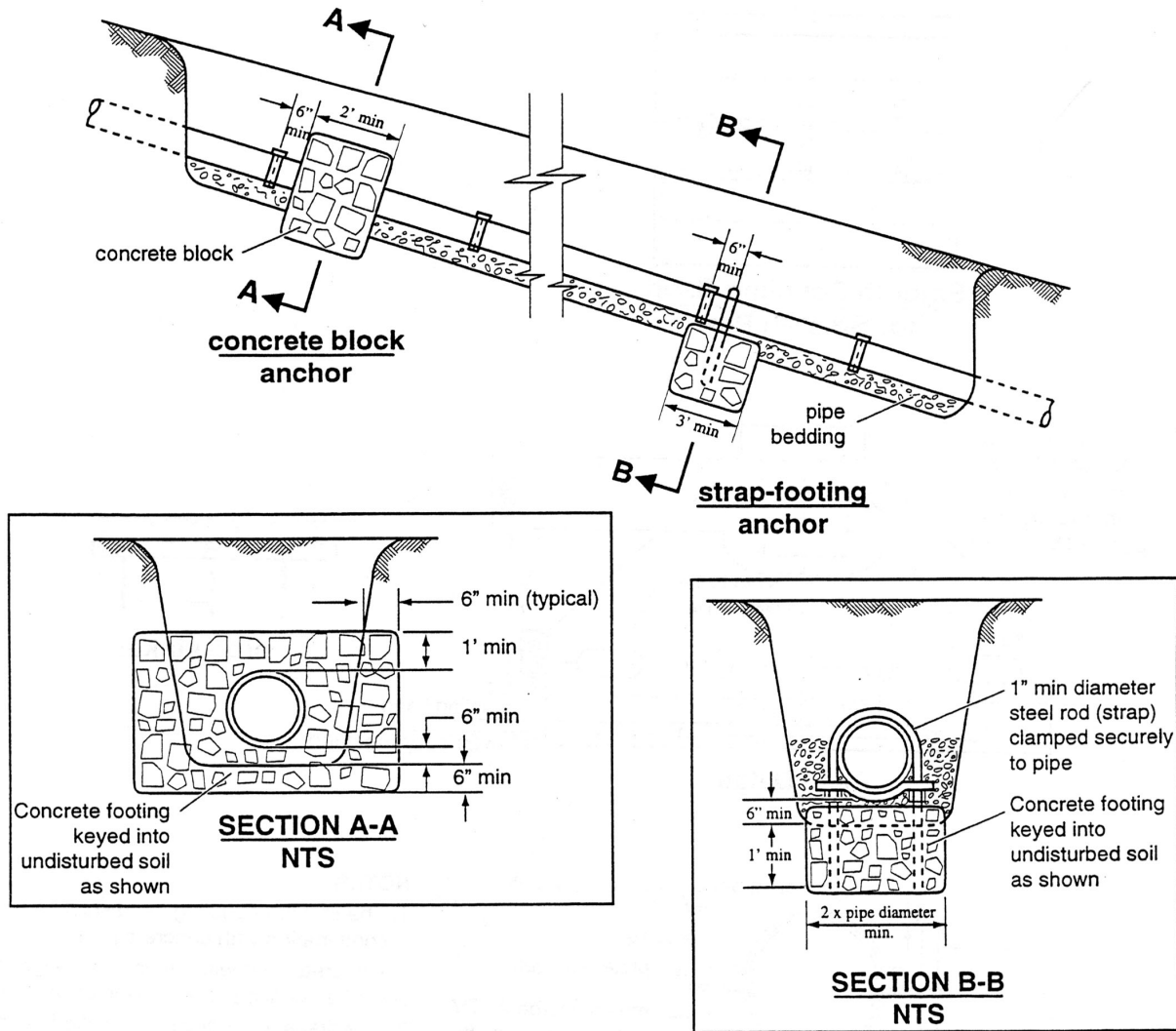


## **FIGURE 4-8 – PIPE COMPACTION DESIGNS AND BACKFILL**

This Figure is currently under development.



**FIGURE 4-9 – PIPE ANCHOR DETAIL**

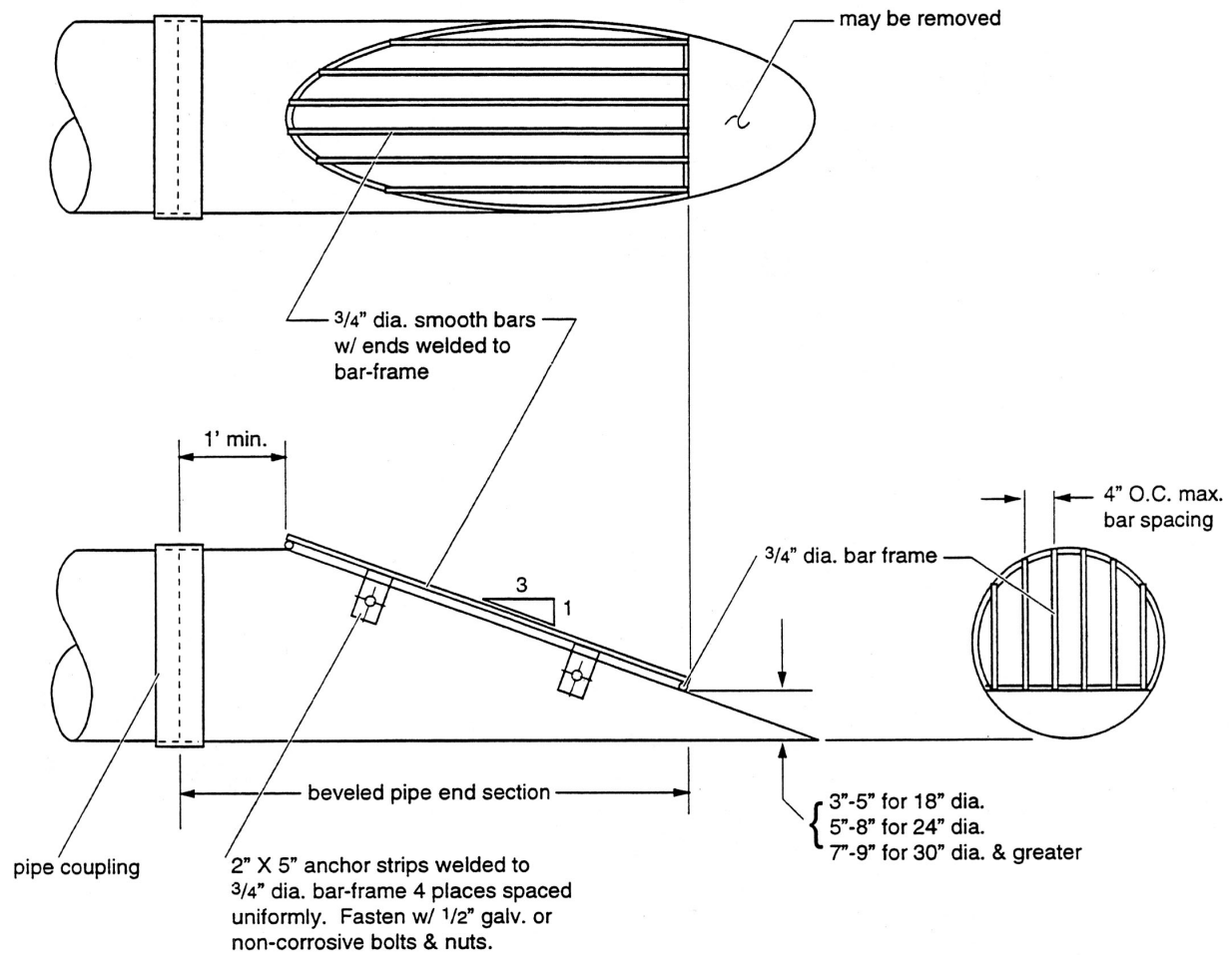


NOTE: For SWPE, pipe must be free to slide inside a 4' long section of pipe one size diameter larger.

## FIGURE 4-10 – DEBRIS BARRIER

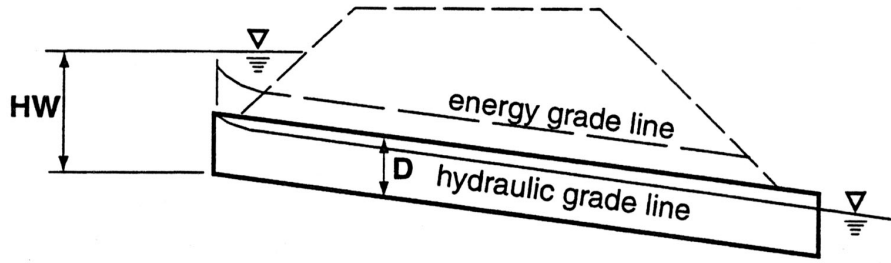
### NOTES:

1. CMP or LCPE pipe end-section shown; for concrete pipe beveled end section, see KCRS drawing No. 2-001.
2. All steel parts must be galvanized and asphalt coated (treatment 1 or better).

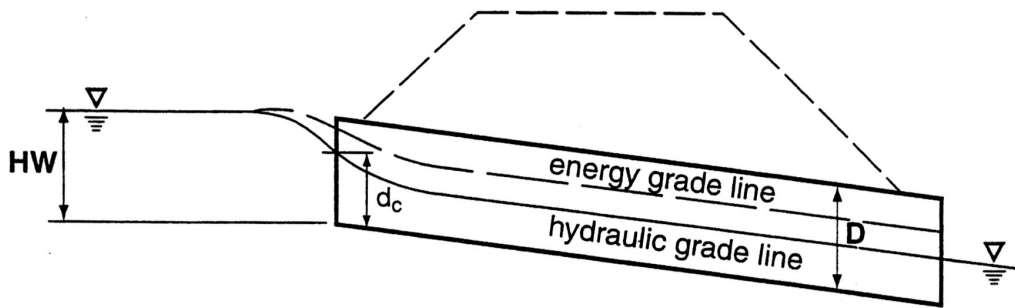


Note: Where debris barriers are required on the downstream end of a pipe, a maximum 6" bar spacing may be used.

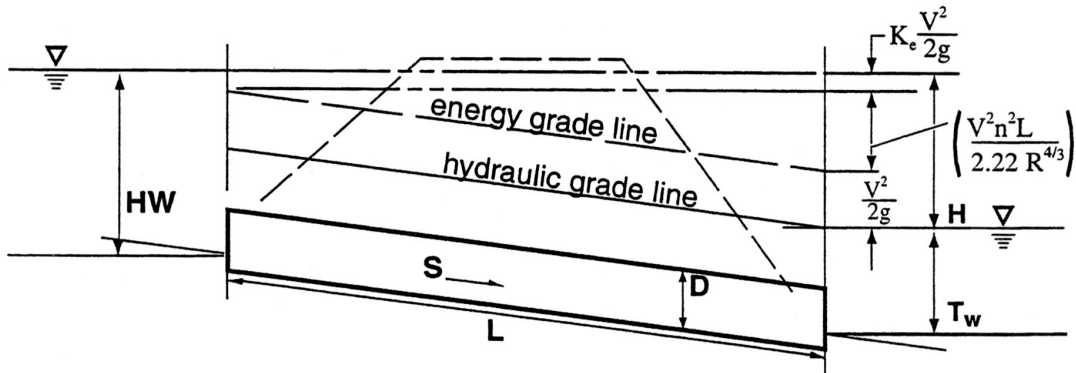
FIGURE 4-11 – INLET/OUTLET CONTROL CONDITIONS



**Inlet Control - Submerged Inlet**



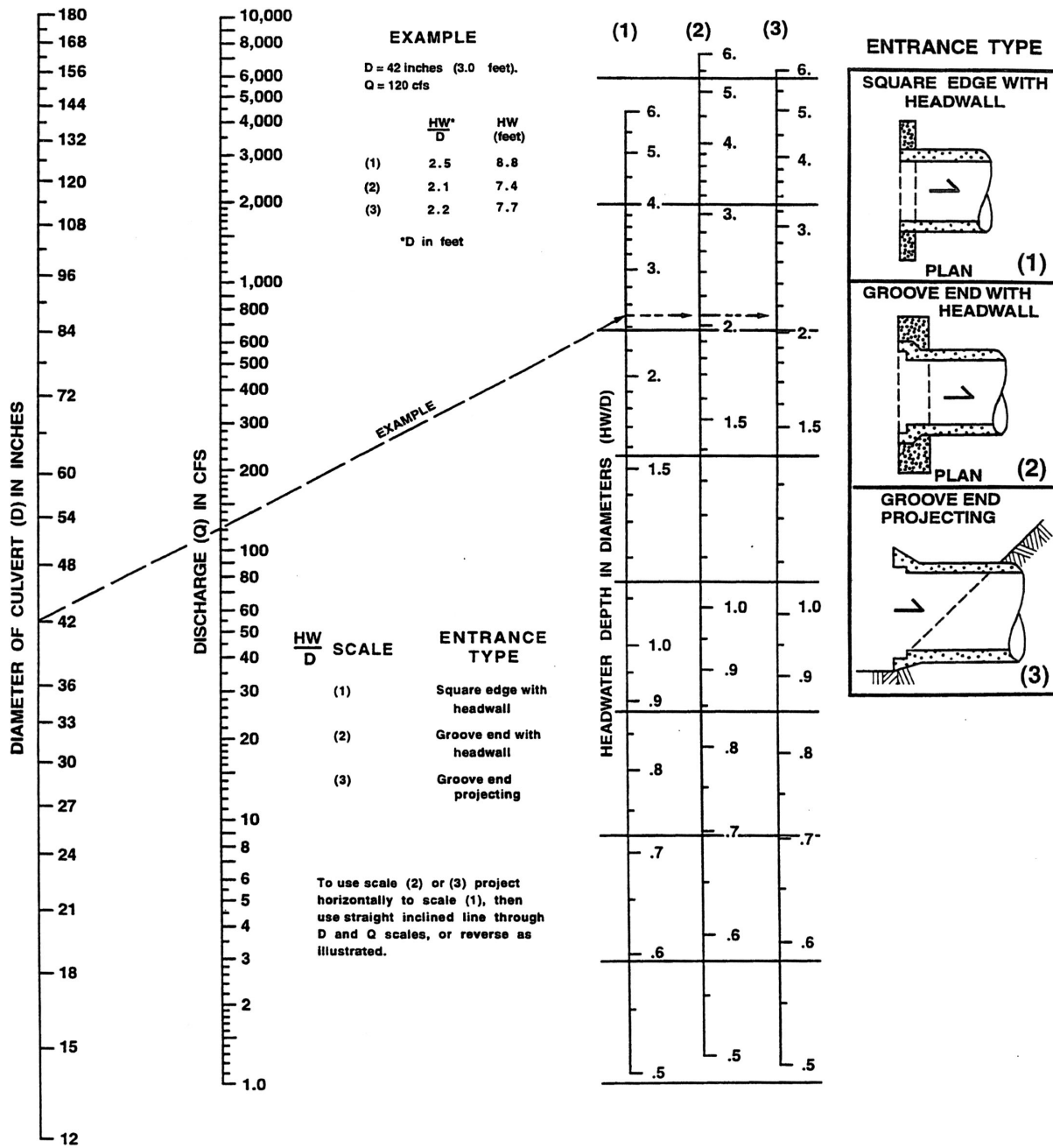
**Inlet Control - Unsubmerged Inlet**



**Outlet Control - Submerged Inlet and Outlet**

NOTE: See FHWA no. 5 for other possible conditions

**FIGURE 4-12 – HEADWATER DEPTH FOR SMOOTH INTERIOR PIPE CULVERTS WITH INLET CONTROL**



**FIGURE 4-13 – HEADWATER DEPTH FOR CORRUGATED PIPE CULVERTS WITH INLET CONTROL**

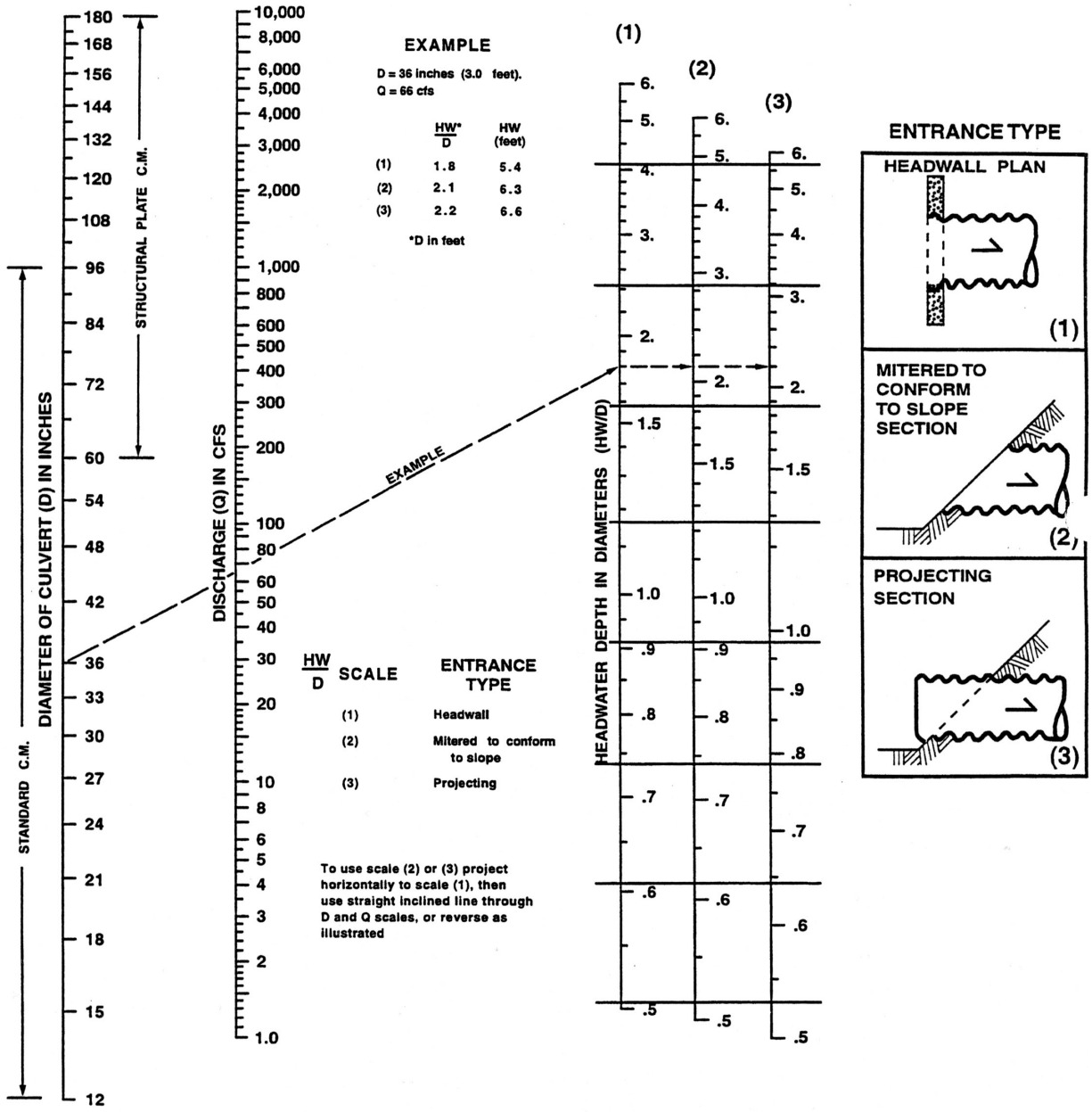


FIGURE 4-14 – HEAD FOR CULVERTS (PIPE W/”N” = 0.012) FLOWING FULL WITH OUTLET CONTROL

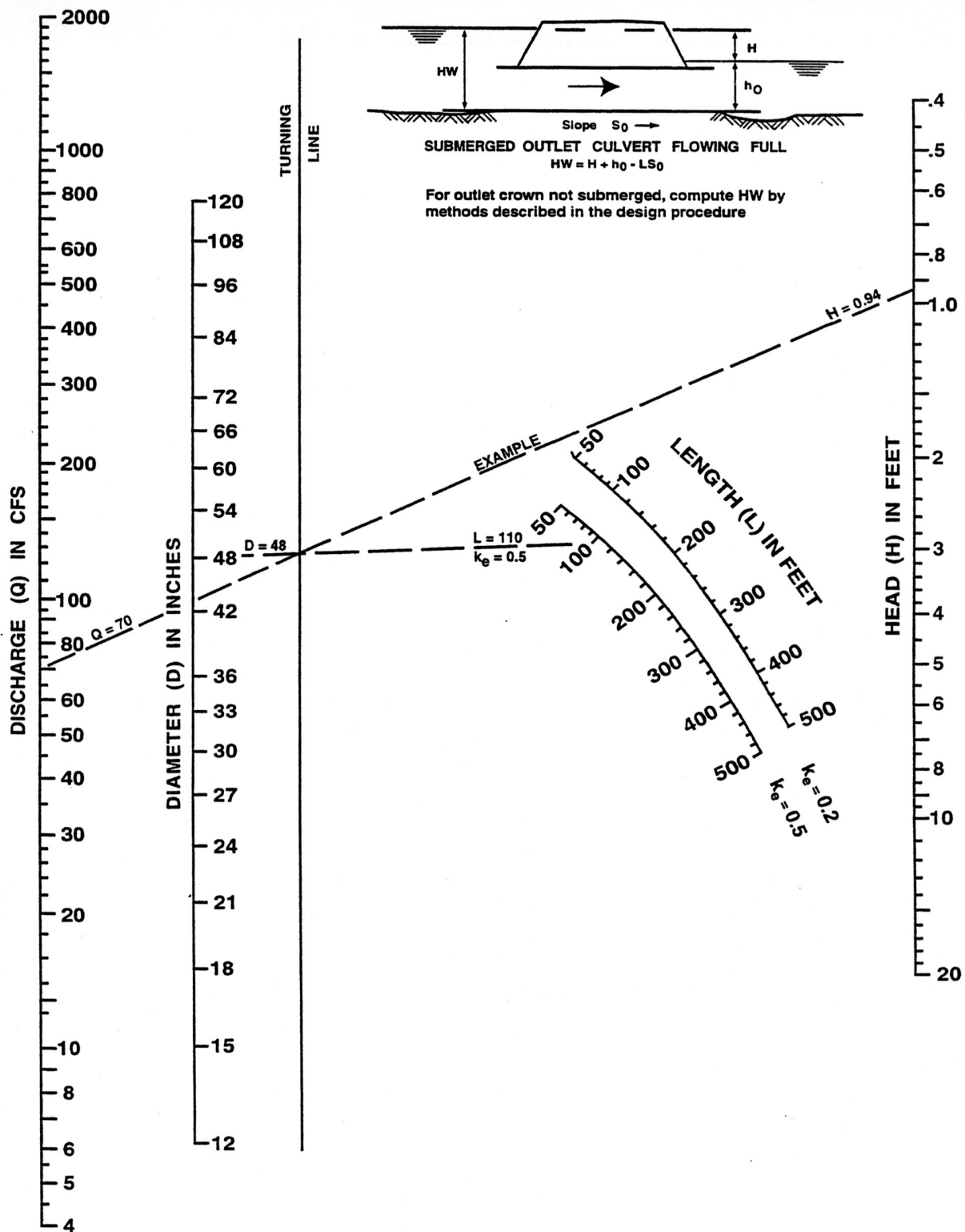
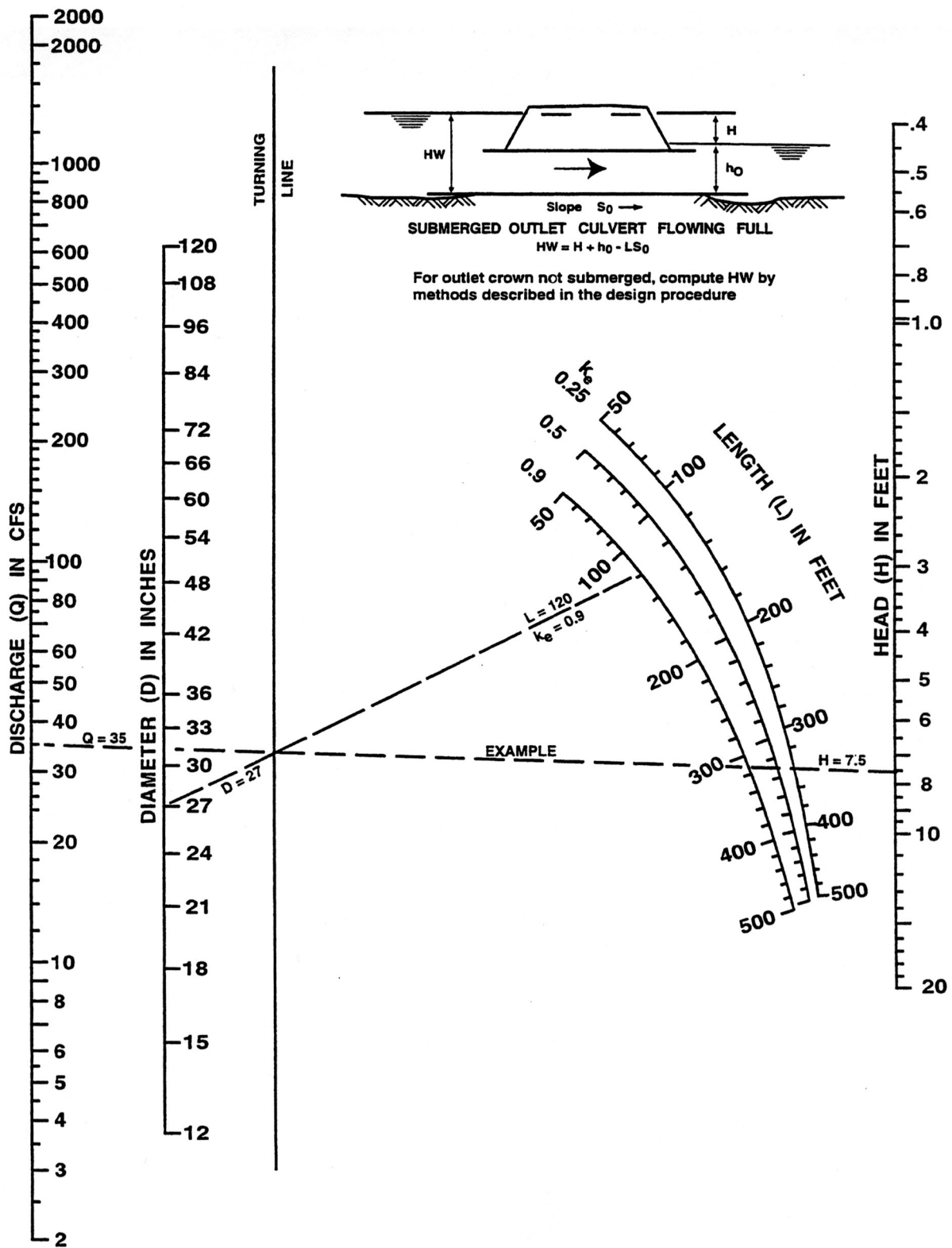
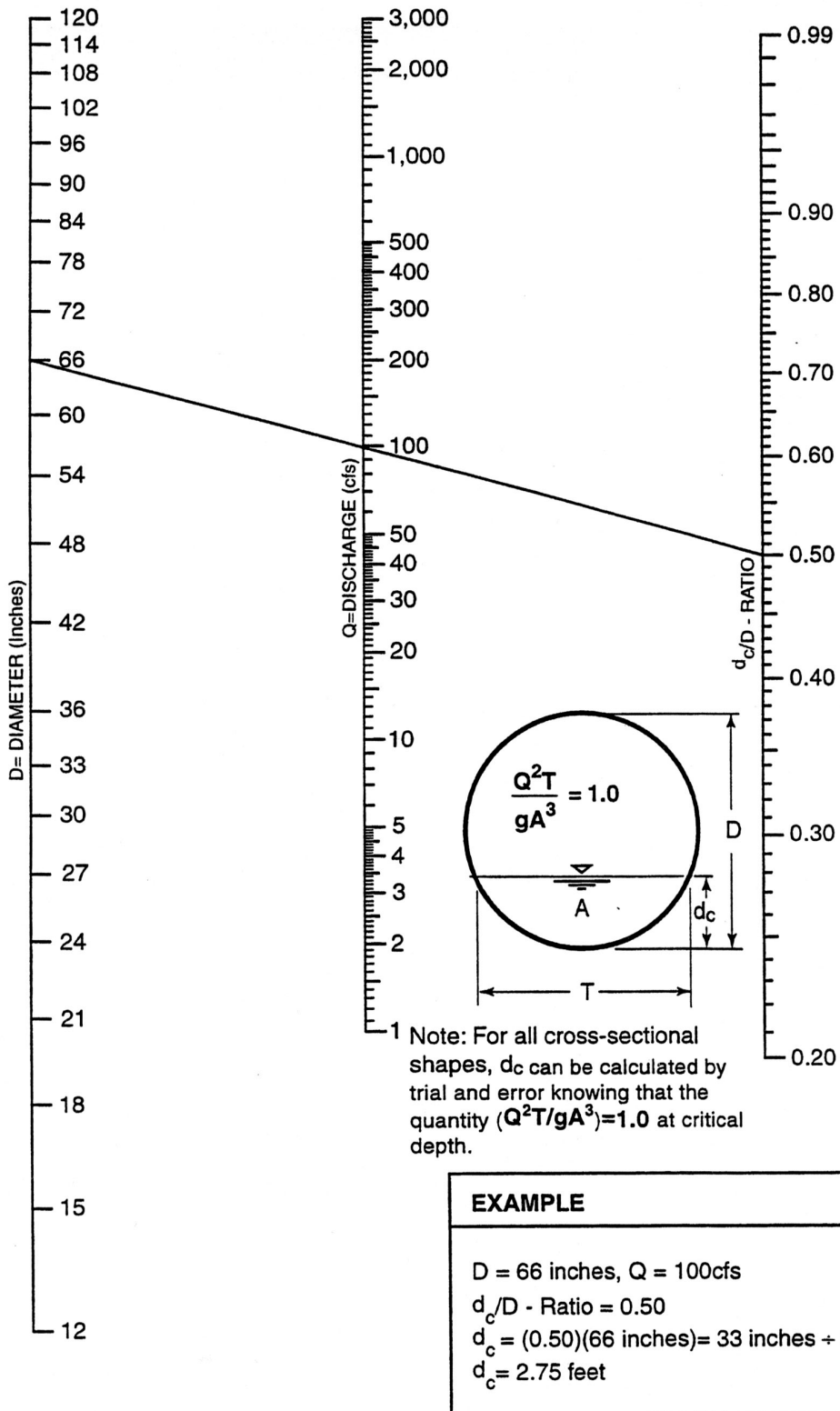


FIGURE 4-15 – HEAD FOR CULVERTS (PIPE W/”N” = 0.024) FLOWING FULL WITH OUTLET CONTROL



**FIGURE 4-16 – CRITICAL DEPTH OF FLOW FOR CIRCULAR CUVLERTS**





**FIGURE 4-17 – MEAN CHANNEL VELOCITY VS. MEDIUM STONE WEIGHT (W50) AND EQUIVALENT STONE DIAMETER**

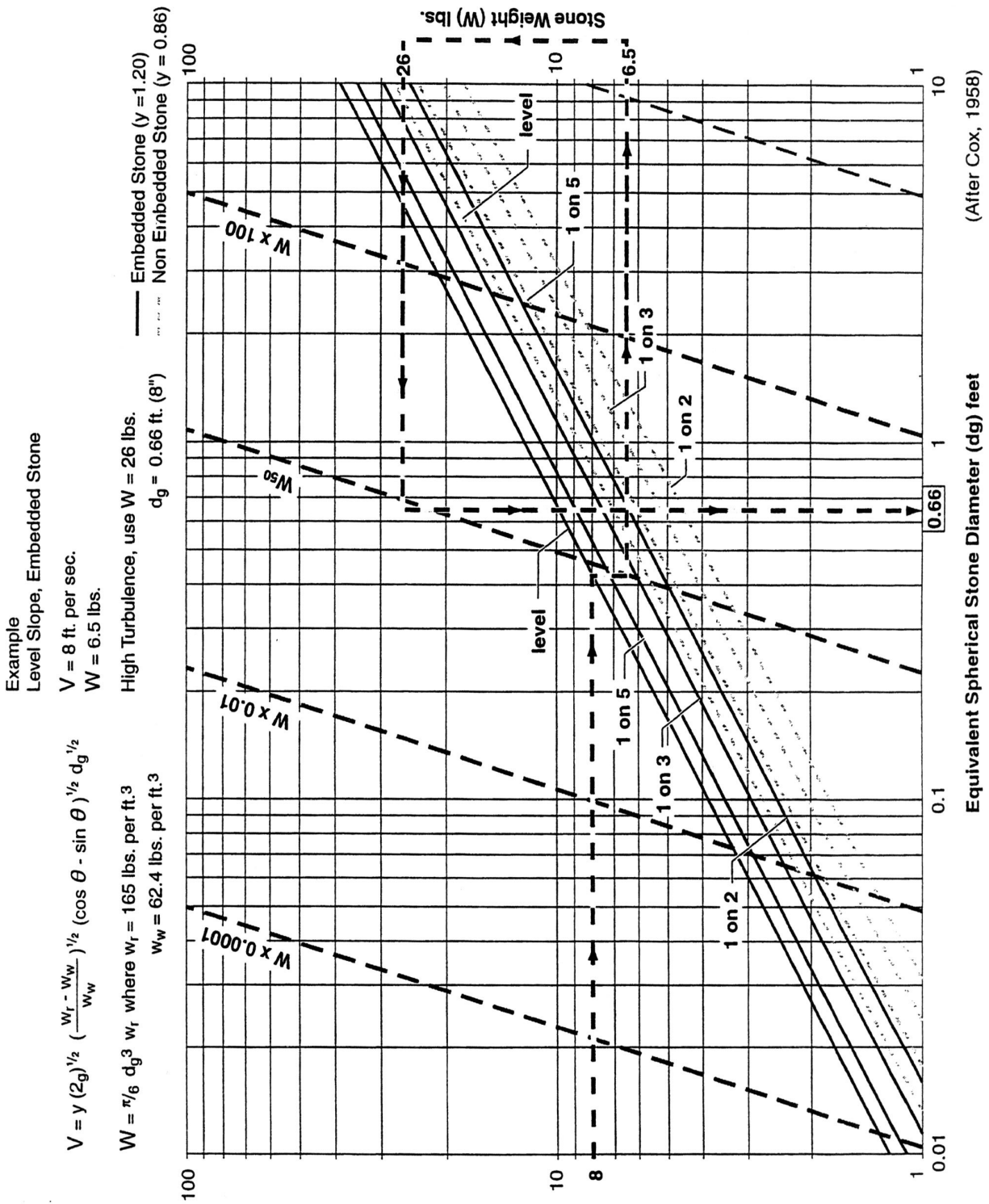


FIGURE 4-18 – RIPRAP GRADATION CURVE

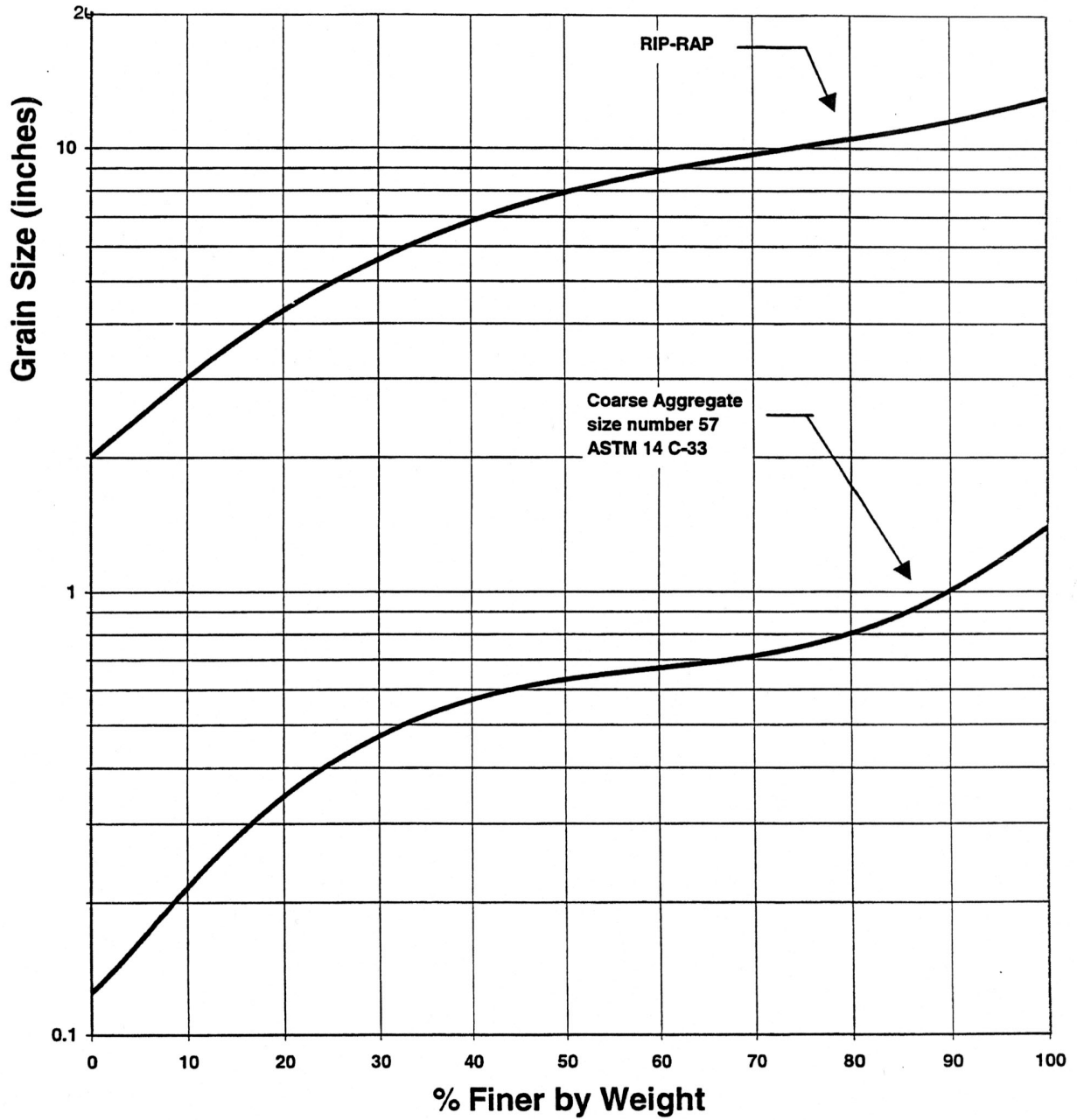
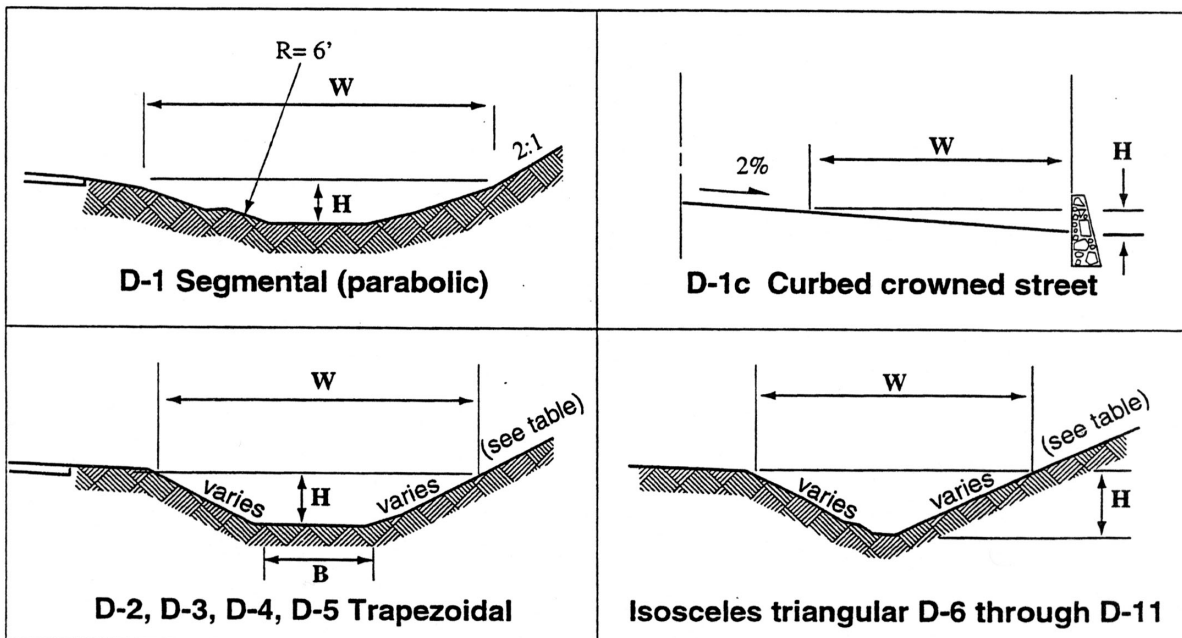


FIGURE 4-19 – DITCHES–COMMON SECTION

PROPERTIES OF DITCHES

NO.	DIMENSIONS				HYDRAULICS			
	Side Slopes	B	H	W	a	p	R	R <sup>(2/3)</sup>
D-1	--	--	6.5"	5'-0"	1.84	5.16	0.356	0.502
D-1C	--	--	6"	25'-0"	6.25	25.50	0.245	0.392
D-2A	1.5:1	2'-0"	1'-0"	5'-0"	3.50	5.61	0.624	0.731
B	2:1	2'-0"	1'-0"	6'-0"	4.00	6.47	0.618	0.726
C	3:1	2'-0"	1'-0"	8'-0"	5.00	8.32	0.601	0.712
D-3A	1.5:1	3'-0"	1'-6"	7'-6"	7.88	8.41	0.937	0.957
B	2:1	3'-0"	1'-6"	9'-0"	9.00	9.71	0.927	0.951
C	3:1	3'-0"	1'-6"	12'-0"	11.25	12.49	0.901	0.933
D-4A	1.5:1	3'-0"	2'-0"	9'-0"	12.00	10.21	1.175	1.114
B	2:1	3'-0"	2'-0"	11'-0"	14.00	11.94	1.172	1.112
C	3:1	3'-0"	2'-0"	15'-0"	18.00	15.65	1.150	1.098
D-5A	1.5:1	4'-0"	3'-0"	13'-0"	25.50	13.82	1.846	1.505
B	2:1	4'-0"	3'-0"	16'-0"	30.00	16.42	1.827	1.495
C	3:1	4'-0"	3'-0"	22'-0"	39.00	21.97	1.775	1.466
D-6A	2:1	--	1'-0"	4'-0"	2.00	4.47	0.447	0.585
B	3:1	--	1'-0"	6'-0"	3.00	6.32	0.474	0.608
D-7A	2:1	--	2'-0"	8'-0"	8.00	8.94	0.894	0.928
B	3:1	--	2'-0"	12'-0"	12.00	12.65	0.949	0.965
D-8A	2:1	--	3'-0"	12'-0"	18.00	13.42	1.342	1.216
B	3:1	--	3'-0"	18'-0"	27.00	18.97	1.423	1.265
D-9	7:1	--	1'-0"	14'-0"	7.00	14.14	0.495	0.626
D-10	7:1	--	2'-0"	28'-0"	28.00	28.28	0.990	0.993
D-11	7:1	--	3'-0"	42'-0"	63.00	42.43	1.485	1.302



**FIGURE 4-20 – DRAINAGE DITCHES—COMMON SECTIONS**

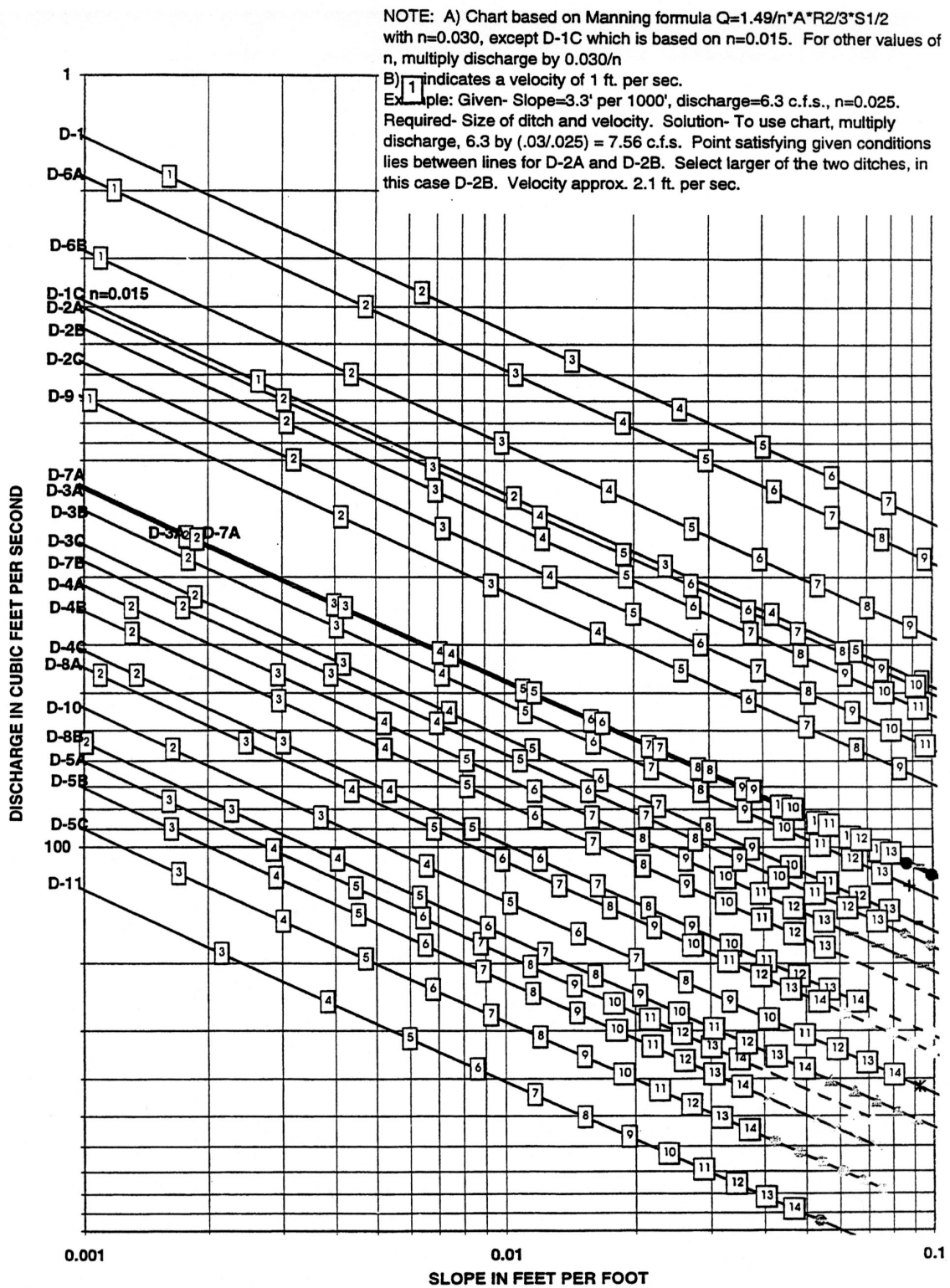
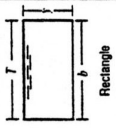
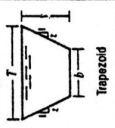
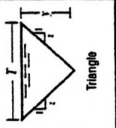
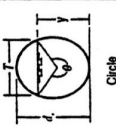
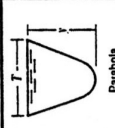
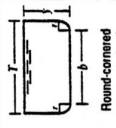
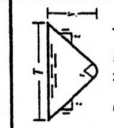


FIGURE 4-21 – GEOMETRIC ELEMENTS OF COMMON SECTIONS

Section	Area A	Wetted perimeter P	Hydraulic radius R	Top width W	Hydraulic depth D	Section factor Z
 Rectangle	$by$	$b + 2y$	$\frac{by}{b + 2y}$	$b$	$y$	$by^{1.5}$
 Trapezoid	$(b + zy)y$	$b + 2y\sqrt{1 + z^2}$	$\frac{(b + zy)y}{b + 2y\sqrt{1 + z^2}}$	$b + 2zy$	$\frac{(b + zy)y}{b + 2zy}$	$\frac{[(b + zy)y]^{1.5}}{\sqrt{b + 2zy}}$
 Triangle	$zy^2$	$2y\sqrt{1 + z^2}$	$\frac{zy}{2\sqrt{1 + z^2}}$	$2zy$	$1/2y$	$\frac{\sqrt{2}}{2}zy^{2.5}$
 Circle	$1/8(\theta - \sin\theta)d^2$	$1/2\theta d$	$1/4(1 - \frac{\sin\theta}{\theta})d$	$(\sin^2(1/2\theta)d)$ or $2\sqrt{y(d-y)}$	$1/8\left(\frac{\theta - \sin\theta}{\sin^2(1/2\theta)}\right)d$	$\frac{\sqrt{2}(\theta - \sin\theta)^{1.5}}{32(\sin^2(1/2\theta))^{0.5}}d^{2.5}$
 Parabola	$2/3Ty$	$T + \frac{8y^2}{3T}$ *	$\frac{2T^2y}{3T^2 + 8y^2}$ *	$\frac{3A}{2y}$	$2/3y$	$2/9\sqrt{6Ty}^{1.5}$
 Round-cornered Rectangle ( $b > r$ )	$(\frac{\pi}{2} - 2)r^2 + (b + 2r)y$	$(\pi - 2)r + b + 2y$	$\frac{(\frac{\pi}{2} - 2)r^2 + (b + 2r)y}{(\pi - 2)r + b + 2y}$	$b + 2r$	$\frac{(\frac{\pi}{2} - 2)r^2}{(b + 2r)} + y$	$\frac{[(\frac{\pi}{2} - 2)r^2 + (b + 2r)y]^{1.5}}{\sqrt{b + 2y}}$
 Round bottomed Triangle	$\frac{T^2}{4z} - \frac{r^2}{z}(1 - z\cot^{-1}z)$	$\frac{T}{z}\sqrt{1 + z^2} - \frac{2r}{z}(1 - z\cot^{-1}z)$	$\frac{A}{P}$	$2[z(y - r) + r\sqrt{1 + z^2}]$	$\frac{A}{T}$	$A\sqrt{\frac{A}{T}}$

\*Satisfactory approximation for the interval  $0 < x \leq 1$ , where  $x = 4y/T$ . When  $x > 1$ , use the exact expression  $P = (\pi/2) [\sqrt{1 + x^2} + 1/x \ln(x + \sqrt{1 + x^2})]$

**FIGURE 4-22 – OPEN CHANNEL FLOW PROFILE COMPUTATION**

$Q =$ _____ $n =$ _____ $S_o =$ _____ $\alpha =$ _____ $Y_n =$ _____												
y (1)	A (2)	R (3)	$R^{4/3}$ (4)	V (5)	$\alpha V^2 / 2g$ (6)	E (7)	$\Delta E$ (8)	$S_f$ (9)	$\bar{S}_f$ (10)	$S_o - \bar{S}_f$ (11)	$\Delta x$ (12)	x (13)

**FIGURE 4-23 – DIRECT STEP BACKWATER METHOD – EXAMPLE**

y (1)	A (2)	R (3)	$R^{4/3}$ (4)	V (5)	$\alpha V^2/2g$ (6)	E (7)	$\Delta E$ (8)	$S_f$ (9)	$\bar{S}_f$ (10)	$S_o - \bar{S}_f$ (11)	$\Delta x$ (12)	x (13)
6.0	72.0	2.68	3.72	0.42	0.0031	6.0031	-	0.00002	-	-	-	-
5.5	60.5	2.46	3.31	0.50	0.0040	5.5040	0.4990	0.00003	0.000025	0.00698	71.50	71.5
5.0	50.0	2.24	2.92	0.60	0.0064	5.0064	0.4976	0.00005	0.000040	0.00696	71.49	142.99
4.5	40.5	2.01	2.54	0.74	0.0098	4.5098	0.4966	0.00009	0.000070	0.00693	71.64	214.63
4.0	32.0	1.79	2.17	0.94	0.0157	4.0157	0.4941	0.00016	0.000127	0.00687	71.89	286.52
3.5	24.5	1.57	1.82	1.22	0.0268	3.5268	0.4889	0.00033	0.000246	0.00675	72.38	358.90
3.0	18.0	1.34	1.48	1.67	0.0496	3.0496	0.4772	0.00076	0.000547	0.00645	73.95	432.85
2.5	12.5	1.12	1.16	2.40	0.1029	2.6029	0.4467	0.00201	0.001387	0.00561	79.58	512.43
2.0	8.0	0.89	0.86	3.75	0.2511	2.2511	0.3518	0.00663	0.004320	0.00268	131.27	643.70

The step computations are carried out as shown in the above table. The values in each column of the table are explained as follows:

- Col. 1. Depth of flow (ft) assigned from 6 to 2 feet
- Col. 2. Water area (ft<sup>2</sup>) corresponding to depth y in Col. 1
- Col. 3. Hydraulic radius (ft) corresponding to y in Col. 1
- Col. 4. Four-thirds power of the hydraulic radius
- Col. 5. Mean velocity (fps) obtained by dividing Q (30 cfs) by the water area in Col. 2
- Col. 6. Velocity head (ft)
- Col. 7. Specific energy (ft) obtained by adding the velocity head in Col. 6 to depth of flow in Col. 1
- Col. 8. Change of specific energy (ft) equal to the difference between the E value in Col. 7 and that of the previous step.
- Col. 9. Friction slope  $S_f$ , computed from V as given in Col. 5 and  $R^{4/3}$  in Col. 4
- Col.10. Average friction slope between the steps, equal to the arithmetic mean of the friction slope just computed in Col. 9 and that of the previous step
- Col.11. Difference between the bottom slope,  $S_o$ , and the average friction slope,  $S_f$
- Col.12. Length of the reach (ft) between the consecutive steps;  
Computed by  $\Delta x = \Delta E / (S_o - S_f)$  or by dividing the value in Col. 8 by the value in Col. 11
- Col.13. Distance from the beginning point to the section under consideration. This is equal to the cumulative sum of the values in Col. 12 computed for previous steps.

There are a number of commercial software programs for use on personal computers that use variations of the Standard Step backwater method for determining water surface profiles. The most common and widely accepted program is called HEC-2, published and supported by the United States Army Corps of Engineers Hydraulic Engineering Center. It is the model required by FEMA for use in performing flood hazard studies for preparing flood insurance maps. Other programs include WSP-2, published by the SCS, and WSPRO or E-431, published by USGS.

## **Appendix III-A**

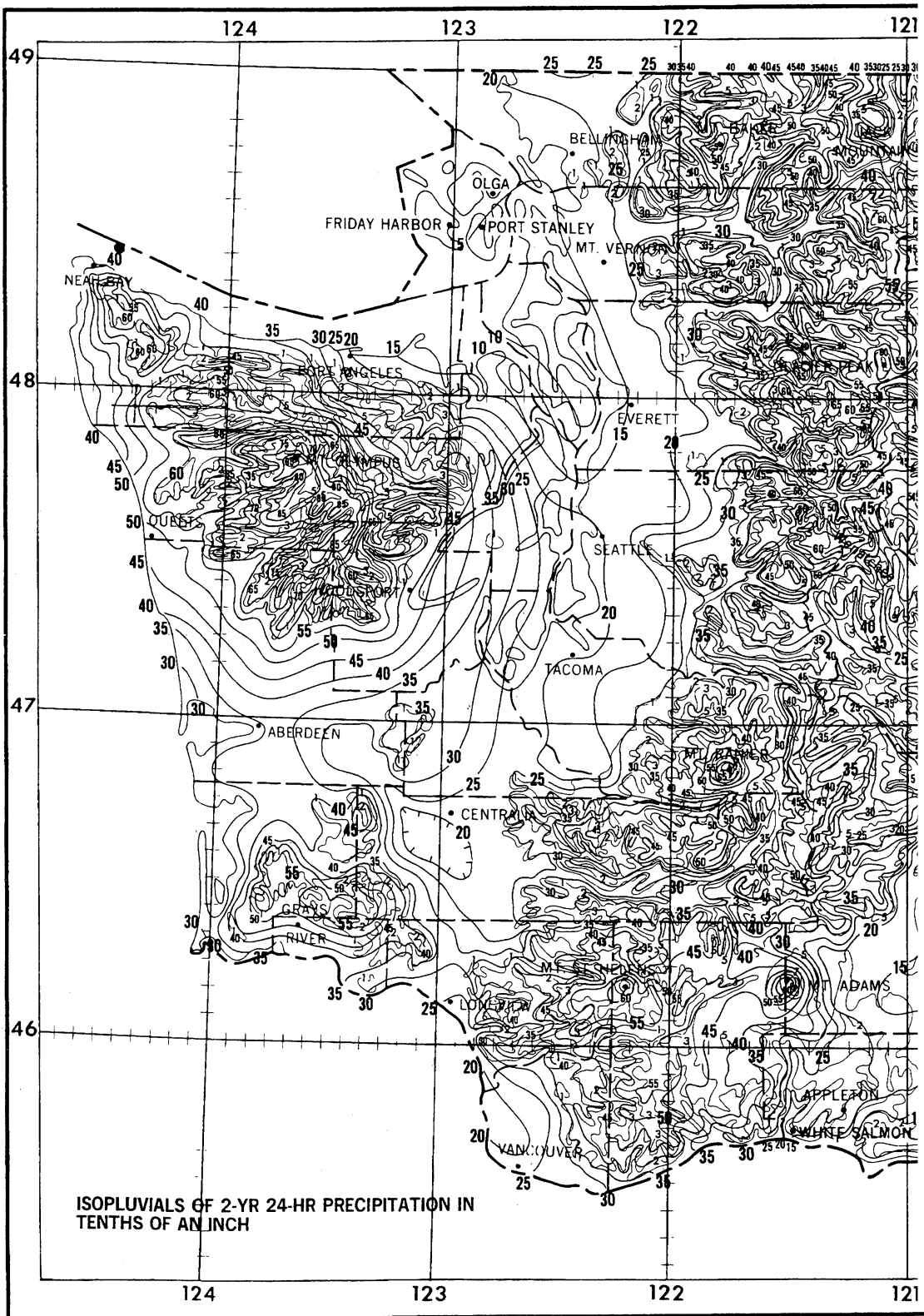
# **Isopluvial Maps for Design Storms**

---

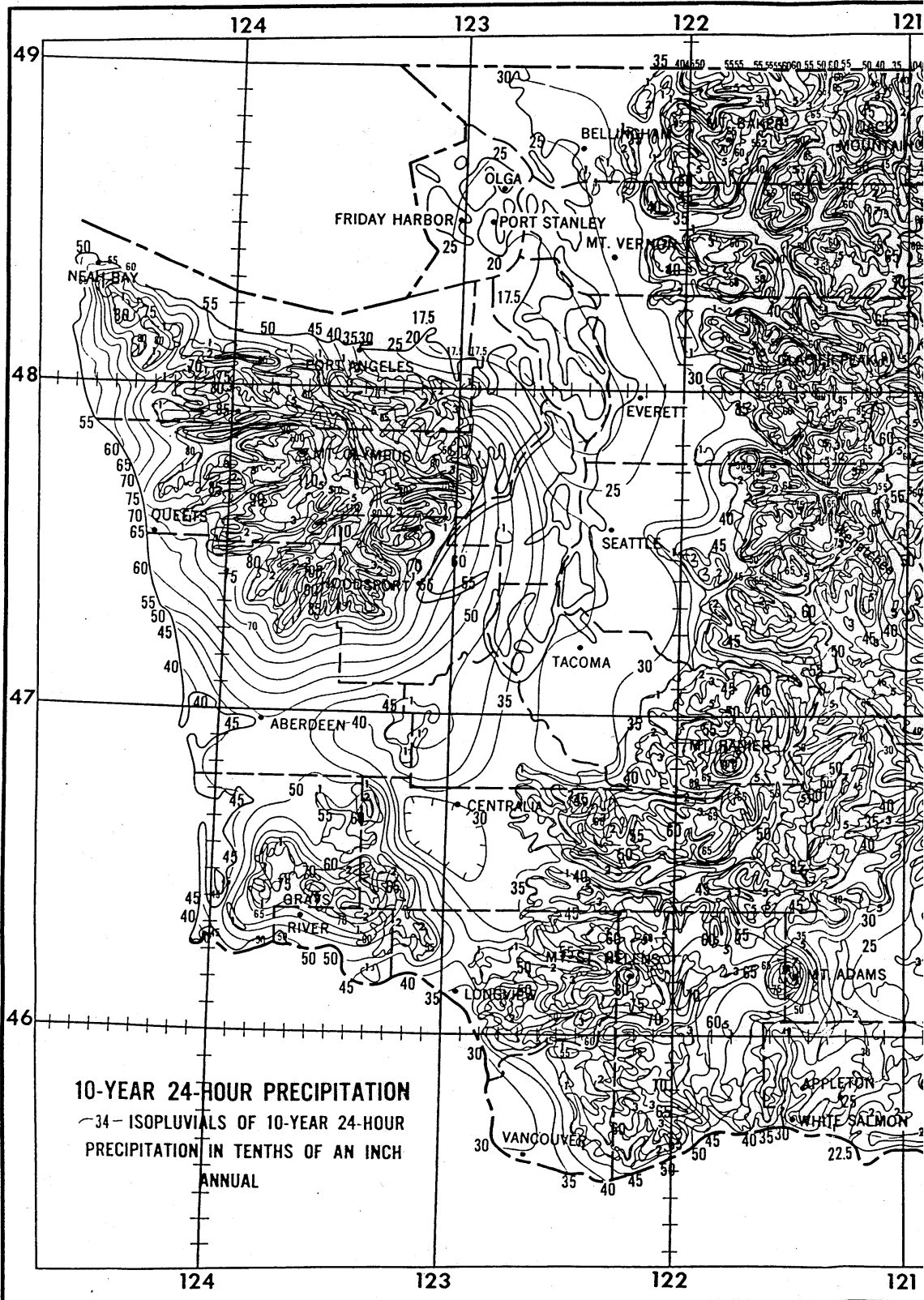
Included in this appendix are the 2, 10 and 100-year, 24-hour design storm and mean annual precipitation isopluvial maps for Western Washington. These have been taken from NOAA Atlas 2 "Precipitation - Frequency Atlas of the Western United States, Volume IX, Washington.



### Western Washington Isopluvial 2-year, 24 hour

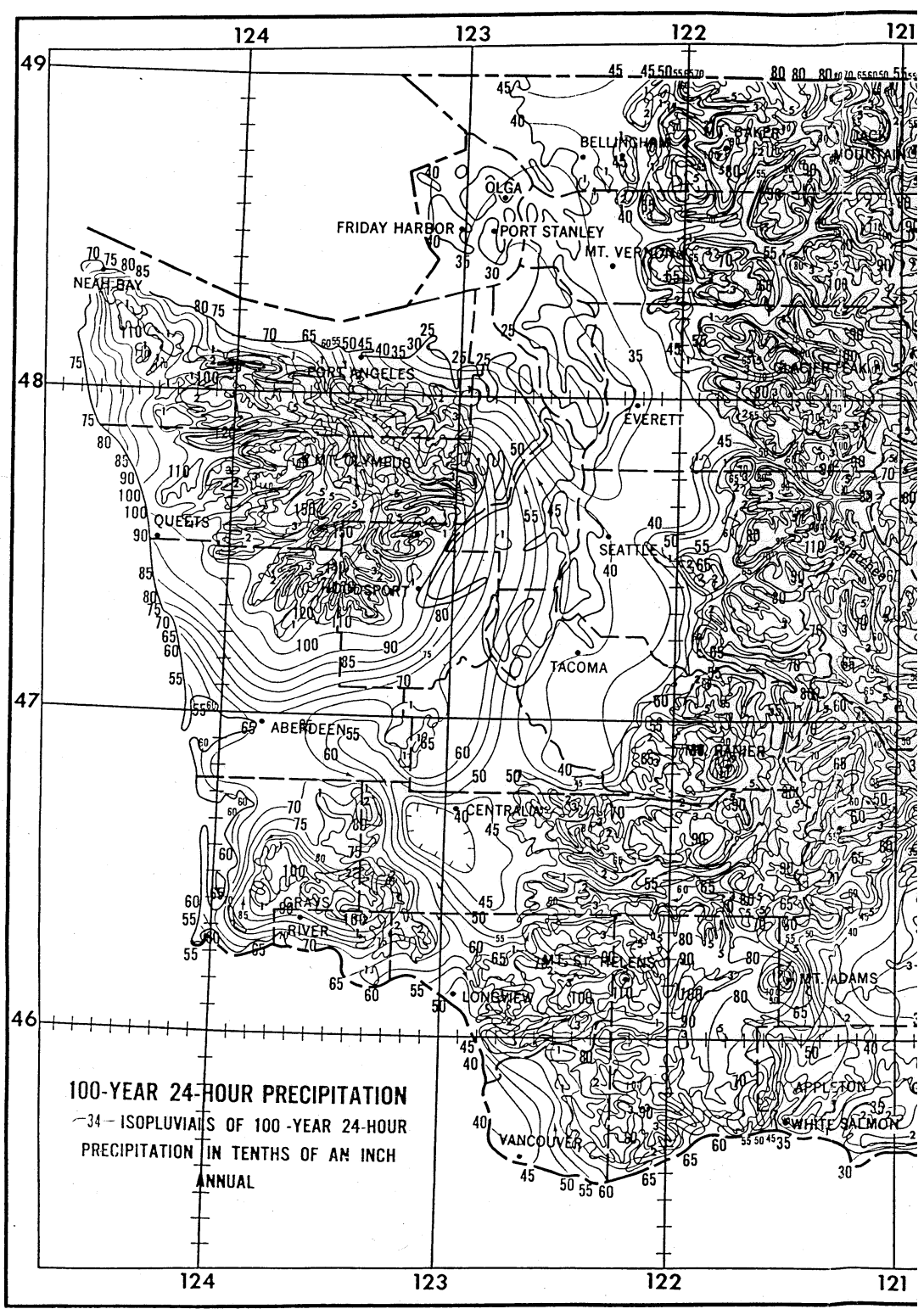


# Western Washington Isopluvial 10-year, 24 hour



USDA-SCS-NATIONAL CARTOGRAPHIC CENTER, FT. WORTH, TX-1986

## Western Washington Isopluvial 100-year, 24 hour



USDA-SCS NATIONAL CARTOGRAPHIC CENTER, FT. WORTH, TX. 1986

# Appendix III-B

## Western Washington Hydrology Model – Information, Assumptions, and Computation Steps

---

The information and assumptions used in the Western Washington Hydrology Model (WWHM) are described in this document.

### WWHM Limitations

The WWHM has been created for the specific purpose of sizing stormwater control facilities for new development and redevelopment projects in Western Washington. The WWHM can be used for a range of conditions and developments; however, certain limitations are inherent in this software. These limitations are described below.

The WWHM uses the EPA HSPF software program to do all of the rainfall-runoff and routing computations. Therefore, HSPF limitations are included in the WWHM. For example, backwater or tailwater control situations are not explicitly modeled by HSPF. This is also true in the WWHM.

In addition, the WWHM is limited in its routing capabilities. The user is allowed to input a single stormwater control facility and runoff is routed through this facility. If the proposed development site contains multiple facilities in series or involves routing through a natural lake, pond, or wetland in addition to a stormwater control facility then the user should use HSPF to do the routing computations and additional analysis.

Routing effects become more important as the drainage area increases. For this reason it is recommended that the WWHM not be used for drainage areas greater than one-half square mile (320 acres). The WWHM can be used for small drainage areas down to less than an acre in size.

### WWHM Information and Assumptions

#### 1. Precipitation data.

##### Length of Record

The WWHM uses long-term (43-50 years) precipitation data to simulate the potential impacts of land use development in western Washington. A minimum period of 20 years is required to simulate enough peak flow events to produce accurate flow frequency results. A 40 to 50-year record is preferred. The actual length of record of each precipitation station varies, but all exceed 43 years.

##### Rainfall Distribution

The precipitation data are representative of the different rainfall regimes found in western Washington. A total of 17 precipitation stations are used. These stations represent rainfall at elevations below 1500 feet. Snowfall and melt are not included in the WWHM.

The primary source for precipitation data is National Weather Service stations. The secondary source is precipitation data collected by local jurisdictions. During development of WWHM, county engineers at 19 western Washington counties were contacted to obtain local precipitation data. Only King County provided local data.

The following precipitation stations have been included in the WWHM:

Precipitation Station	Years of Data	County Coverage
Astoria, OR	1955-1998 = 43	Wahkiakum
Blaine	1948-1998 = 50	Whatcom, San Juan
Burlington	1948-1998 = 50	Skagit, Island
Clearwater	1948-1998 = 50	Jefferson (west)
Darrington	1948-1996 = 48	Snohomish (northeast)
Everett	1948-1996 = 48	Snohomish (excluding northeast)
Frances	1948-1998 = 50	Pacific
Landsburg	1948-1997 = 49	King (east)
Longview	1955-1998 = 43	Cowlitz, Lewis (south)
McMillian	1948-1998 = 50	Pierce
Montesano	1955-1998 = 43	Grays Harbor
Olympia	1955-1998 = 43	Thurston, Mason (south), Lewis (north)
Port Angeles	1948-1998 = 50	Clallam (east)
Portland, OR	1948-1998 = 50	Clark, Skamania
Quilcene	1948-1998 = 50	Jefferson (west), Mason (north), Kitsap
Sappho	1948-1998 = 50	Clallam (west)
SeaTac	1948-1997 = 49	King (west)

The records were reviewed for length, quality, and completeness of record. Annual totals were checked along with hourly maximum totals. Using these checks, data gaps and errors were corrected, where possible. A "Quality of Record" summary was produced for each precipitation record reviewed.

The reviewed and corrected data were placed in multiple WDM (Watershed Data Management) files. One WDM file was created per county and contains all of the precipitation data to be used by the WWHM for that particular county.

### Computational Time Step

The computational time step used in the WWHM is one hour. The one-hour time step was selected to better represent the temporal variability of actual precipitation than daily data.

## **2. Precipitation multiplication factors.**

Precipitation multiplication factors increase or decrease recorded precipitation data to better represent local rainfall conditions. This is particularly important when the precipitation gage is located some distance from the study area.

Precipitation multiplication factors were developed for western Washington. The factors are based on the ratio of the 24-hour, 25-year rainfall intensities for the representative precipitation gage and the surrounding area represented by that gage's record. The 24-hour, 25-year rainfall

intensities were determined from the NOAA Atlas 2 (*Precipitation-Frequency Atlas of the Western United States, Volume IX – Washington, 1973*).

These multiplication factors were created for the Puget Sound lowlands plus all western Washington valleys and hillside slopes below 1500 feet elevation. The factors were placed in the WWHM database and linked to each county's map. They are transparent to the general user. The advanced user will have the ability to change the precipitation multiplication factor for a specific site. However, such changes will be recorded in the WWHM output.

### **3. Pan evaporation data.**

Pan evaporation data are used to determine the potential evapotranspiration (PET) of a study area. Actual evapotranspiration (AET) is computed by the WWHM based on PET and available moisture supply. AET accounts for the precipitation that returns to the atmosphere without becoming runoff. Soil moisture conditions and runoff are directly influenced by PET and AET.

Evaporation is not highly variable like rainfall. Puyallup pan evaporation data are used for all of the 19 western Washington counties.

Pan evaporation data were assembled and checked for the same time period as the precipitation data and placed in the appropriate county WDM files.

Pan evaporation data are collected in the field, but PET is used by the WWHM. PET is equal to pan evaporation times a pan evaporation coefficient. Depending on climate, pan evaporation coefficients for western Washington range from 0.72 to 0.82.

NOAA Technical Report NWS 33, *Evaporation Atlas for the Contiguous 48 United States*, was used as the source for the pan evaporation coefficients. Pan evaporation coefficient values are shown on Map 4 of that publication.

As with the precipitation multiplication factors, the pan evaporation coefficients have been placed in the WWHM database and linked to each county's map. They will be transparent to the general user. The advanced user will have the ability to change the coefficient for a specific site. However, such changes will be recorded in the WWHM output.

### **4. Soil data.**

Soil type, along with vegetation type, greatly influences the rate and timing of the transformation of rainfall to runoff. Sandy soils with high infiltration rates produce little or no surface runoff; almost all runoff is from groundwater. Soils with a compressed till layer slowly infiltrate water and produce larger amounts of surface runoff during storm events.

The WWHM uses three predominate soil type to represent the soils of western Washington: till, outwash, and saturated

Till soils have been compacted by glacial action. Under a layer of newly formed soil lies a compressed soil layer commonly called "hardpan". This hardpan has very poor infiltration capacity. As a result, till soils produce a relatively large amount of surface runoff and interflow. A typical example of a till soil is an Alderwood soil (SCS class C).

Outwash soils have a high infiltration capacity due to their sand and gravel composition. Outwash soils have little or no surface runoff or interflow. Instead, almost of their runoff is in the form of groundwater. An Everett soil (SCS class A) is a typical outwash soil.

Outwash soils over high groundwater or an impervious soil layer have low infiltration rates and act like till soils. Where groundwater or an impervious soil layer is within 5 feet from the surface, outwash soils may be modeled as till soils in the WWHM.

Saturated soils are usually found in wetlands. They have a low infiltration rate and a high groundwater table. When dry, saturated soils have a high storage capacity and produce very little runoff. However, once they become saturated they produce surface runoff, interflow, and groundwater in large quantities. Mukilteo muck (SCS class D) is a typical saturated soil.

The user will be required to investigate actual local soil conditions for the specific development planned. The user will then input the number of acres of outwash (A/B), till (C), and saturated (D) soils for the site conditions.

Alluvial soils are found in valley bottoms. These are generally fine-grained and often have a high seasonal water table. There has been relatively little experience in calibrating the HSPF model to runoff from these soils, so in the absence of better information, these soils may be modeled as till soils.

Additional soils will be included in the WWHM if appropriate HSPF parameter values are found to represent other major soil groups.

The three predominate soil types are represented in the WWHM by specific HSPF parameter values that represent the hydrologic characteristics of these soils. More information on these parameter values is presented below.

## **5. Vegetation data.**

As with soil type, vegetation types greatly influence the rate and timing of the transformation of rainfall to runoff. Vegetation intercepts precipitation, increases its ability to percolate through the soil, and evaporates and transpires large volumes of water that would otherwise become runoff.

The WWHM will represent the vegetation of western Washington with three predominate vegetation categories: forest, pasture, and lawn (also known as grass).

Forest vegetation represents the typical second growth Douglas fir found in the Puget Sound lowlands. Forest has a large interception storage capacity. This means that a large amount of precipitation is caught in the forest canopy before reaching the ground and becoming available for runoff. Precipitation intercepted in this way is later evaporated back into the atmosphere. Forest also has the ability to transpire moisture from the soil via its root system. This leaves less water available for runoff.

Pasture vegetation is typically found in rural areas where the forest has been cleared and replaced with shrub or grass lots. Some pasture areas may be used to graze livestock. The interception storage and soil evapotranspiration capacity of pasture are less than forest. Soils may have also been compressed by mechanized equipment during clearing activities.

Livestock can also compact soil. Pasture areas typically produce more runoff (particularly surface runoff and interflow) than forest areas.

Lawn vegetation is representative of the suburban vegetation found in typical residential developments. Soils have been compacted by earth moving equipment, often with a layer of topsoil removed. Sod and ornamental bushes replace native vegetation. The interception storage and evapotranspiration of lawn vegetation is less than pasture. More runoff results.

Predevelopment default land conditions are forest, although the user has the option of specifying pasture if there is documented evidence that pasture vegetation was native to the predevelopment site. If this option is used, the change will be recorded in the WWHM output.

Forest vegetation is represented by specific HSPF parameter values that represent the forest hydrologic characteristics. As described above, the existing regional HSPF parameter values for forest are based on undisturbed second-growth Douglas fir forest found today in western Washington lowland watersheds.

Postdevelopment vegetation will reflect the new vegetation planned for the site. The user has the choice of forest, pasture, and landscaped vegetation. Forest and pasture are only appropriate for postdevelopment vegetation in parcels separate from standard residential or non-standard residential/commercial. Development areas must only be designated as forest or pasture where legal restrictions can be documented that protect these areas from future disturbances. The WWHM assumes the pervious land portion of the standard residential and non-standard residential/commercial is covered with lawn vegetation, as described above.

## **6. Development land use data.**

Development land use data are used to represent the type of development planned for the site and are used to determine the appropriate size of the required stormwater mitigation facility.

For the purposes of the WWHM in Western Washington developed land is divided into two major categories:

1. Standard residential, and
2. Non-standard residential/commercial.

### Standard Residential

Standard residential development makes specific assumptions about the amount of impervious area per lot and its division between driveways and rooftops. Streets and sidewalk areas are input separately. Ecology has selected a standard impervious area of 4200 square feet per residential lot, with 1000 square feet of that as driveway, walkways, and patio area, and the remainder as rooftop area.

Impervious, as the name implies, allows no infiltration of water into the pervious soil. All runoff is surface runoff. Impervious land typically consists of paved roads, sidewalks, driveways, and parking lots. Roofs are also impervious.

For the purposes of hydrologic modeling, only effective impervious area is categorized as impervious. Effective impervious area (EIA) is the area where there is no opportunity for surface runoff from an impervious site to infiltrate into the soil before it reaches a conveyance



system (pipe, ditch, stream, etc.). An example of an EIA is a shopping center parking lot where the water runs off the pavement and directly goes into a catch basin where it then flows into a pipe and eventually to a stream. In contrast, some homes with impervious roofs collect the roof runoff into roof gutters and send the water down downspouts. When the water reaches the base of the downspout it can be directed either into a pipe or dumped on a splash block. Roof water dumped on a splash block then has the opportunity to spread out into the yard and soak into the soil. Such roofs are not considered to be effective impervious area. For hydrologic modeling purposes, runoff credits are given to developments that contain houses that have roof runoff systems that disperse roof runoff and allow it to drain into the soil. A runoff credit is given by assuming in the modeling that the roof area behaves hydrologically as lawn rather than EIA.

The non-effective impervious area uses the adjacent or underlying soil and vegetation properties. Vegetation often varies by the type of land use. Standard residential and non-standard residential/commercial are both assumed to have lawn as their typical pervious area vegetation.

The assumption is made in the WWHM that the EIA equals the TIA (total impervious area). This is consistent with King County's determination of EIA acres for new developments. Where appropriate, the TIA can be reduced through the use of runoff credits (more on that below).

For standard residential developments the user will input the impervious area in the public right-of-way (streets and sidewalks). In addition, the user will input the number of residential lots and the number of acres associated directly with these residential lots (public right-of-way acreages and non-residential lot acreages excluded). The number of residential lots and the associated number of acres will be used to compute the average number of residential lots per acre. This value together with the number of residential lots and the impervious area in the public right-of-way will be used by the model to calculate the TIA for the proposed development.

Runoff credits will be given reducing runoff from standard residential lots. Runoff credits can be obtained using any or all of the three methods described below.

1. Infiltrate roof runoff
2. Disperse roof runoff
3. Use porous pavement for driveway areas

Credit is given for disconnecting the roof runoff from the development's stormwater conveyance system and infiltrating on the individual residential lots. The WWHM assumes that this infiltrated roof runoff does not contribute to the runoff flowing to the stormwater detention pond site. It disappears from the system and does not have to be mitigated.

Credit is also given for disconnecting the roof runoff from the development's stormwater conveyance system and dispersing it on the surface of individual lots. This runoff is assumed to be the equivalent of runoff from lawn vegetation.

The third option for runoff credit is the use of porous pavement for private driveway areas. Specific HSPF parameters for porous pavement have not been developed for the WWHM. Ecology has made the assumption that porous pavement runoff is the equivalent to the conversion of 147 square feet ( $1000 \times 0.147$ ) of impervious area to lawn vegetation. This assumption is used in the WWHM calculations.

Forest and pasture vegetation areas are only appropriate for separate undeveloped parcels dedicated as open space, wetland buffer, or park within the total area of the standard residential development. ***Development areas must only be designated as forest or pasture where legal restrictions can be documented that protect these areas from future disturbances.***

#### Non-Standard Residential/Commercial

Non-standard residential/commercial development includes residential developments for which the standard residential developments assumptions are inappropriate, plus commercial, industrial, schools, roads, multi-family residential (apartments, condos), and other non-single family residential developments. For this type of development the user will input the roof area, landscape area, street/sidewalk/parking areas, and any appropriate non-developed forest and pasture areas. Developed runoff will be calculated based on these categories and their areas. The only explicit runoff credit available to the user is porous pavement for streets, sidewalks, and parking lots. The credit works the same way as for standard residential. It is specified as 14.7% of the total street/sidewalk/ parking impervious area. The user can also implicitly obtain other runoff credits by decreasing or eliminating roof area where roof runoff is infiltrated or by modeling roof area as lawn where roof runoff is dispersed in accordance with the infiltration and dispersion requirements in Chapter 3. This will decrease surface runoff.

Forest and pasture vegetation areas are only appropriate for separate undeveloped parcels dedicated as open space, wetland buffer, or park within the total area of the development. ***Development areas must only be designated as forest or pasture where legal restrictions can be documented that protect these areas from future disturbances.***

#### Other Development Options and Model Features

The WWHM allows the flexibility of bypassing a portion of the development area around a flow control facility and/or having offsite inflow that is entering the development area pass through the flow control facility. Three options are available to the user:

- A. Design Basin: usual development situation with no offsite inflow and no flow bypass.
- B. Bypass: a portion of the development does not drain to a stormwater detention facility. Onsite runoff from a proposed development project may bypass the flow control facility provided that all of the following conditions are met.
  - 1. Runoff from both the bypass area and the flow control facility converges within a quarter-mile downstream of the project site discharge point, and
  - 2. The flow control facility is designed to compensate for the uncontrolled bypass area such that the net effect at the point of convergence downstream is the same with or without bypass, and
  - 3. The 100-year peak discharge from the bypass area will not exceed 0.4 cfs, and
  - 4. Runoff from the bypass area will not create a significant adverse impact to downstream drainage systems or properties, and
  - 5. Water quality requirements applicable to the bypass area are met.
- C. Offsite Inflow: an upslope area outside the development drains to the flow control facility in the development. If the existing 100-year peak flow rate from any upstream offsite area is greater than 50% of the 100-year developed peak flow rate (undetained) for the project site,

then the runoff from the offsite area must not flow to the onsite flow control facility. The bypass of offsite runoff must be designed so as to achieve the following:

1. Any existing contribution of flows to an onsite wetland must be maintained, and
2. Offsite flows that are naturally attenuated by the project site under predeveloped conditions must remain attenuated, either by natural means or by providing additional onsite detention so that peak flows do not increase.

For each of these options the user inputs the number of acres in the different categories for the predevelopment and postdevelopment land use. The WWHM computes the runoff from each separately and adds them together, as appropriate, to check to see if the stormwater standards have been satisfied. The following

WWHM uses this information to compute the corresponding number of acres of pervious and impervious land and assign these acres to specific PERLNDs and IMPLNDs. These terms are HSPF-speak for pervious land categories and impervious land categories. WWHM uses the PERLNDs and IMPLNDs to compute postdevelopment runoff.

#### Application of WWHM in Re-developments Projects

WWHM allows only forest or pasture as the predevelopment land condition in the Design Basin screen. This screen does not allow other types of land uses such as impervious and landscaped areas to be entered for existing condition. However, WWHM can be used for redevelopment projects by modeling the existing developed areas that are not subject to the flow control requirements of Volume I as offsite areas. For the purposes of predicting runoff from such an existing developed area, enter the existing area in the Offsite Inflow screen. This screen is designed to predict runoff from impervious and landscaped areas in addition to the forest and pasture areas. If the existing 100-year peak flow rate from the existing developed areas that are not subject to flow control is greater than 50% of the 100-year developed peak flow rate (undetained but subject to the flow control requirements of Volume I), then the runoff from the offsite area must not be allowed to flow to the onsite flow control facility.

#### **7. PERLND and IMPLND parameter values.**

In WWHM (and HSPF) pervious land categories are represented by PERLNDs; impervious land categories (EIA) by IMPLNDs. An example of a PERLND is a till soil covered with forest vegetation. This PERLND has a unique set of HSPF parameter values. For each PERLND there are 16 parameters that describe various hydrologic factors that influence runoff. These range from interception storage to infiltration to active groundwater evapotranspiration. Only four parameters are required to represent IMPLND.

The PERLND and IMPLND parameter values to be used in the WWHM are listed below. These values are based on regional parameter values developed by the U.S. Geological Survey for watersheds in western Washington (Dinicola, 1990) plus additional HSPF modeling work conducted by AQUA TERRA Consultants.

## PERLND Parameters

	TF	TP	TL	OF	OP	OL	SF	SP	SL
Name									
LZSN	4.5	4.5	4.5	5.0	5.0	5.0	4.0	4.0	4.0
INFILT	0.08	0.06	0.03	2.0	1.6	0.80	2.0	1.8	1.0
LSUR	400	400	400	400	400	400	100	100	100
SLSUR	0.10	0.10	0.10	0.10	0.10	0.10	0.001	0.001	0.001
KVARY	0.5	0.5	0.5	0.3	0.3	0.3	0.5	0.5	0.5
AGWRC	0.996	0.996	0.996	0.996	0.996	0.996	0.996	0.996	0.996
INFEXP	2.0	2.0	2.0	2.0	2.0	2.0	10.0	10.0	10.0
INFILD	2.0	2.0	2.0	2.0	2.0	2.0	2.0	2.0	2.0
BASETP	0.0	0.0	0.0	0.0	0.0	0.0	0.0	0.0	0.0
AGWETP	0.0	0.0	0.0	0.0	0.0	0.0	0.7	0.7	0.7
CEPSC	0.20	0.15	0.10	0.20	0.15	0.10	0.18	0.15	0.10
UZSN	0.5	0.4	0.25	0.5	0.5	0.5	3.0	3.0	3.0
NSUR	0.35	0.30	0.25	0.35	0.30	0.25	0.50	0.50	0.50
INTFW	6.0	6.0	6.0	0.0	0.0	0.0	1.0	1.0	1.0
IRC	0.5	0.5	0.5	0.7	0.7	0.7	0.7	0.7	0.7
LZETP	0.7	0.4	0.25	0.7	0.4	0.25	0.8	0.8	0.8

### PERLND types:

TF = Till Forest  
 TP = Till Pasture  
 TL = Till Lawn  
 OF = Outwash Forest

OP = Outwash Pasture  
 OL = Outwash Lawn  
 SF = Saturated Forest  
 SP = Saturated Pasture  
 SL = Saturated Lawn

### PERLND parameters:

LZSN = lower zone storage nominal (inches)  
 INFILT = infiltration capacity (inches/hour)  
 LSUR = length of surface overland flow plane (feet)  
 SLSUR = slope of surface overland flow plane (feet/feet)  
 KVARY = groundwater exponent variable (inch<sup>-1</sup>)  
 AGWRC = active groundwater recession constant (day<sup>-1</sup>)  
 INFEXP = infiltration exponent  
 INFILD = ratio of maximum to mean infiltration  
 BASETP = base flow evapotranspiration (fraction)  
 AGWETP = active groundwater evapotranspiration (fraction)  
 CEPSC = interception storage (inches)  
 UZSN = upper zone storage nominal (inches)  
 NSUR = roughness of surface overland flow plane (Manning's n)  
 INTFW = interflow index  
 IRC = interflow recession constant (day<sup>-1</sup>)  
 LZETP = lower zone evapotranspiration (fraction)

A more complete description of these PERLND parameters is found in the HSPF User Manual (Bicknell et al, 1997).

PERLND parameter values for other additional soil/vegetation categories will be investigated and added to the WWHM, as appropriate.

## IMPLND Parameters

	EIA
Name	
LSUR	400
SLSUR	0.01
NSUR	0.10
RETSC	0.10

IMPLND parameters:

LSUR = length of surface overland flow plane (feet)

SLSUR = slope of surface overland flow plane (feet/feet)

NSUR = roughness of surface overland flow plane (Manning's n)

RETSC = retention storage (inches)

A more complete description of these IMPLND parameters is found in the HSPF User Manual (Bicknell et al, 1997).

The PERLND and IMPLND parameter values will be transparent to the general user. The advanced user will have the ability to change the value of a particular parameter for that specific site. However, such changes will be recorded in the WWHM output.

Surface runoff and interflow will be computed based on the PERLND and IMPLND parameter values. Groundwater flow will not be computed, as it is assumed that there is no groundwater flow from small catchments that reaches the surface to become runoff. This is consistent with King County procedures (King County, 1998).

### **8. Guidance for flow control standards.**

Flow control standards are used to determine whether or not a proposed stormwater facility will provide a sufficient level of mitigation for the additional runoff from land development. Guidance is provided on the standards that must be met to comply with the Ecology Stormwater Management Manual.

There are two flow control standards stated in the Ecology Manual: Minimum Requirement #7 - Flow Control and Minimum Requirement #8 - Wetlands Protection (See Volume I).

Minimum Requirement #7 specifies flow frequency and flow duration ranges for which the postdevelopment runoff cannot exceed predevelopment runoff. Minimum Requirement #8 specifies that discharges to wetlands must maintain the hydrologic conditions, hydrophytic vegetation, and substrate characteristics necessary to support existing and designated beneficial uses.

Minimum Requirement #7 specifies that stormwater discharges to streams shall match developed discharge durations to predeveloped durations for the range of predeveloped discharge rates from 50% of the 2-year peak flow up to the full 50-year peak flow. In addition, the developed peak discharge rates should not exceed the predeveloped peak discharge rates for 2-, 10-, and 50-year return periods. In general, matching discharge durations between 50% of the 2-year and 50-year will result in matching the peak discharge rates in this range.

The WWHM uses the predevelopment peak flow value for each water year to compute the predevelopment 2- through 100-year flow frequency values. The postdevelopment runoff 2- through 100-year flow frequency values are computed from the outlet of the proposed stormwater facility. The user must enter the stage-surface area-storage-discharge table (HSPF FTABLE) for the stormwater facility. The model then routes the postdevelopment runoff through the stormwater facility. As with the predevelopment peak flow values, the maximum developed flow value for each water year will be selected by the model to compute the developed 2- through 100-year flow frequency.

The actual flow frequency calculations are made using the federal standard Log Pearson Type III distribution described in Bulletin 17B (United States Water Resources Council, 1981). This standard flow frequency distribution is provided in U.S. Geological Survey program J407, version 3.9A-P, revised 8/9/89. The Bulletin 17B algorithms in program J407 are included in the WWHM calculations.

The WWHM compares the postdevelopment 2-year flow frequency value with the predevelopment flood value. If the postdevelopment value is greater than the predevelopment value then flow frequency requirement has not been met. The same test is conducted for the 5-, 10-, 25-, 50-, and 100-year flow frequency values. The results are reported in the WWHM output.

The second half of the Minimum Requirement #7 is based on flow duration. The WWHM will use the entire predevelopment and postdevelopment runoff record to compute flow duration. The standard requires that postdevelopment runoff flows must not exceed the flow duration values of the predevelopment runoff between the predevelopment flow values of 50 percent of the 2-year flow and 100 percent of the 50-year flow.

Flow duration is computed by counting the number of flow values that exceed a specified flow level. The specified flow levels used by WWHM in the flow duration analysis are listed below.

1. 50% of the 2-year predevelopment peak flow.
2. 100% of the 2-year predevelopment peak flow.
3. 100% of the 50-year predevelopment peak flow.

In addition, flow durations are computed for 97 other incremental flow values between 50 percent of the 2-year predevelopment peak flow and 100 percent of the 50-year predevelopment peak flow.

There are three criteria by which flow duration values are compared:

1. If the postdevelopment flow duration values exceed any of the predevelopment flow levels between 50% and 100% of the 2-year predevelopment peak flow values (100 Percent Threshold) then the flow duration requirement has not been met.
2. If the postdevelopment flow duration values exceed any of the predevelopment flow levels between 100% of the 2-year and 100% of the 50-year predevelopment peak flow values more than 10 percent of the time (110 Percent Threshold) then the flow duration requirement has not been met.
3. If more than 50 percent of the flow duration levels exceed the 100 percent threshold then the flow duration requirement has not been met.

The results are provided in the WWHM report.

Minimum Requirement #8 specifies that discharges to wetlands must maintain the hydrologic conditions, hydrophytic vegetation, and substrate characteristics necessary to support existing and designated beneficial uses. Criteria for determining maximum allowed exceedences in alterations to wetland hydroperiods are provided in guidelines cited in Guide Sheet 2B of the Puget Sound Wetland Guidelines (Azous and Horner, 1997).

Because wetland hydroperiod computations are relatively complex and are site specific, they will not be included in the WWHM. HSPF is required for wetland hydroperiod analysis. Ecology intends to determine the appropriate steps in using HSPF to compute hydroperiod based on joint recommendations from wetland biologists and HSPF modelers.

## **WWHM Computation Steps**

### **STEP 1. Location project site.**

Drag flag to project site on map.  
Zoom in or out on map, as needed.  
Click on NEXT.

### **STEP 2. Input land area data.**

Type in Name of Development, Development Address, City/County, and Project Description.  
Select Standard Residential or Non-standard/Commercial.

For Standard Residential:

For Design Basin (project site) input number of acres of  
Predeveloped Soils

Outwash (A&B)

Till (C)

Saturated (D)

Select Predeveloped Vegetation (Forest or Pasture)

Residential Acres

Lot Acres (excluding public right-of-ways and non-residential parcels)

Streets/Sidewalks (public right-of-ways)

Forest (undeveloped parcels only)

Pasture (undeveloped parcels only)

Landscaped Area (parks, etc., excluding residential lots)

Each of the above must be separated into A/B soils and C soils.

(NOTE: Saturated (D) soil areas should not be included in the developed area acres as these are wetland areas.)

Number of Lots (corresponding to the total Lot Acres)

(NOTE: the user is allowed a maximum of 10 lots per acre.)

Roof Runoff Credits (if appropriate)

Infiltrate (percent of lots)

Disperse (percent of lots)

Pavement Credit (if appropriate)

Porous Pavement (private pavement areas only)

Repeat information (if necessary) for Bypass.

Repeat information (if necessary) for Offsite Inflow.

Click NEXT.

Compute Runoff now? Click Yes.

For Non-standard/Commercial:

For Design Basin (project site) input number of acres of

Predeveloped Soils

Outwash (A&B)

Till (C)

Saturated (D)

Select Predeveloped Vegetation (Forest or Pasture)

Non-standard Residential/Commercial

Impervious Area (Roof acres)

Landscaped Area (pervious acres)

Streets/Sidewalks/Parking

Forest (undeveloped parcels only)

Pasture (undeveloped parcels only)

Each of the above must be separated into A/B soils and C soils.

(NOTE: Saturated (D) soil areas should not be included in the developed area acres as these are wetland areas.)

Pavement Credit (if appropriate)

Porous Pavement (percent of total Streets/Sidewalks/Parking)

Repeat information (if necessary) for Bypass.

Repeat information (if necessary) for Offsite Inflow.

Click NEXT.

Compute Runoff now? Click Yes.

### **STEP 3. Compute runoff.**

HSPF executes for predevelopment and postdevelopment conditions.

Click NEXT.

### **STEP 4. Perform flow frequency analysis.**

Click PERFORM to compute flow frequency values for predevelopment (black), flow duration values for predevelopment (red), and flow frequency values for postdevelopment without stormwater detention facility (blue).

2-Year to 100-Year flow frequency results are reported for the predevelopment and postdevelopment without detention facility conditions. If the difference in the 100-year flow frequency values is less than 0.1 cfs then no facility is required.

If needed to size a stormwater facility, click EXPORT to export either predevelopment, postdevelopment (without routing through stormwater facility), or postdevelopment (with routing through stormwater facility) runoff time series to a separate file.

Click NEXT.

### **STEP 5. Check stormwater detention facility.**

Enter Facility Name/ID and Type of Facility.

Add Table from File or enter manually the following information:

Stage/depth (feet) starting zero

Area (acres) of surface corresponding to stage, starting at zero

Storage (acre-feet) of facility corresponding to stage, starting at zero



Discharge1 (cfs) from facility to surface flow, corresponding to stage, starting at zero  
If the stormwater facility is an infiltration facility then click on Infiltration and enter:  
Discharge2 (cfs) from facility to subsurface flow, corresponding to stage, starting at zero

NOTE:

- (1) the first row of values must be zero;
- (2) stage must increase from one row to next;
- (3) storage must increase from one row to next;
- (4) maximum number of total values cannot exceed 500.

Click NEXT.

Compute Runoff now? Click Yes.

Postdevelopment runoff is routed through the stormwater facility.

Click NEXT.

### **STEP 6. Perform flow frequency analysis for postdevelopment runoff with stormwater detention facility.**

Click NEXT.

### **STEP 7. Compare flow duration statistics for predevelopment and postdevelopment runoff with stormwater detention facility.**

Click lower PERFORM to compute flow frequency values for postdevelopment with stormwater detention facility (black) and flow duration values for postdevelopment with facility (red).

2-Year to 100-Year flow frequency results are reported for the postdevelopment with detention facility. Compare with predevelopment conditions.

Change 110 Percent Threshold (default value) if required by Ecology or local jurisdiction, otherwise use default value.

Click Perform Statistical Analysis to compare predevelopment and postdevelopment flow duration values.

Identify which values passed or failed the test.

Click NEXT.

### **STEP 8. Ecology Flow Control Standard Summary.**

Summary information shows whether the stormwater facility passes or fails the Ecology flow control standard.

To view a complete listing of the input and output information:

- (1) save the file (File, Save Project As, enter File name, Save)
- (2) click Generate Report
- (3) view and/or print Report

To exit the WWHM: File, Exit

## **References for Western Washington Hydrology Model**

Beyerlein, D.C. 1996. Effective Impervious Area: The Real Enemy. Presented at the Impervious Surface Reduction Research Symposium, The Evergreen State College. Olympia, WA.

Bicknell, B.R., J.C. Imhoff, J.L. Kittle Jr, A.S. Donigian Jr, and R.C. Johanson. 1997. Hydrological Simulation Program – Fortran User's Manual for Version 11. EPA/600/R-97/080. National Exposure Research Laboratory. Office of Research and Development. U.S. Environmental Protection Agency. Research Triangle Park, NC.

Dinicola, R.S. 1990. Characterization and Simulation of Rainfall-Runoff Relations for Headwater Basins in Western King and Snohomish Counties, Washington. Water-Resources Investigations Report 89-4052. U.S. Geological Survey. Tacoma, WA.

King County. 1998. Surface Water Design Manual. Department of Natural Resources. Seattle, WA.

United States Water Resources Council. 1981. Guidelines for Determining Flood Flow Frequency. Bulletin #17B of the Hydrology Committee. Washington, DC.

## **Appendix III-C Stormwater Details**

---

This Appendix is currently under development.

## Volume III References

---

- Chin, D.A., Water Resources Engineering, Prentice Hall, New Jersey, 2000
- Chow, V.T., Handbook of Applied Hydrology, McGraw Hill Book Co., New York, 1964.
- Department of Ecology, Stormwater Management Manual for the Puget Sound Basin, February, 1992.
- Dinacola, R.S., Characterization and Simulation of Rainfall-Runoff Relations for Headwater Basins in Western King and Snohomish Counties, Washington, USGS Water Resources Investigations Report 89-4052, 1989.
- Ferguson, Bruce K., Stormwater Infiltration, Lewis Publishers, 1994.
- Horner, Richard Fundamentals of Urban Runoff Management-Technical and Institutional Issues, 1994
- Huber, Wayne, and Robert Dickinson, Stormwater Management Model Version 4 Part A: User's Manual, Environmental Research Laboratory, Athens, GA, 1988.
- King County Runoff Time Series (KCRTS), King County Department of Natural Resources, Personal Communication, 1999.
- Massmann, Joel & Carolyn Butchart, U. of Washington Infiltration Characteristics, Performance, and Design of Storm Water Facilities, March 2000
- NOAA Atlas 2, Precipitation Frequency Atlas of the Western United States, Volume IX- Washington.
- Rawls, W. J., Brakensiek, D. L. and Saxton, K. E. Estimation of Soil Properties. Transactions of the American Society of Agricultural Engineers, Vol. 25, No. 5, pp. 1316-1320, 1982.
- Stubdaer, J.M., The Santa Barbara Urban Hydrograph Method, National Symposium on Urban Hydrology and Sediment Control, University of Kentucky, Lexington, KY, 1975.
- USDA-SCS, Technical Release No. 20 (TR-20) Model Project Formulation, 1982.
- USDA-SCS, Technical Release No. 55: Urban Hydrology for Small Watersheds, 1986.
- USEPA, Hydrological Simulation Program - Fortran HSPF Users Manual for Release 9., EPA 600/3-84-066, Environmental Research Laboratory, Athens, GA, June 1984.
- Wiltzie, Edward, Stormwater Facilities Performance Study, Infiltration Pond Testing and Data Evaluation, August 10, 1998

## **Resource Materials (not specifically referenced in text)**

- Barfield, B. J., and Warner, R. C., and Haan, C. T. Applied Hydrology and Sedimentology for Disturbed Areas. Oklahoma Technical Press, Stillwater, Oklahoma, 1983.
- Bentall, R., Methods of Collecting and Interpreting Ground Water Data, U.S. G. S. Water Supply Paper 1544-H., 1963, 97 p.
- Bianchi, W.C. and D.C. Muckel, Ground Water Recharge Hydrology, ARS 41-161, USDA, 1970. 62 p.
- Bouwer, Herman., Groundwater Hydrology, McGraw-Hill Book Company, Inc., N.Y., 1978.
- Camp Dresser & McKee, Larry Walker Associates, Uribe and Associates, and Resource Planning Associates. California Storm Water Best Management Practice Handbooks. March 1993
- Caraco, D., Claytor, R., Stormwater BMP Design Supplement for Cold Climates USEPA, December 1997
- Davis, S.N. and R.J. DeWiest, Hydrogeology. John Wiley and Sons, N.Y., 1966.
- Ferguson, Bruce K., Stormwater Infiltration, Lewis Publishers, 1994.
- Ferris, J.G., D.B. Knowles, R.H. Brown, and R.W. Stallman, Theory of Aquifer Tests, USGS, Water Supply Paper No. 1536-E.
- Gaus, Jennifer J., Soils of Stormwater Infiltration Basins in the Puget Sound Region: Trace Metal Form and Concentration and Comparison to Washington State Department of Ecology Guidelines, Master of Science, U. of Washington, 1993.
- Hannon, J. B., Underground Disposal of Storm Water Runoff, Design Guidelines Manual, California Department of Transportation, U.S. Department of Transportation, Washington, DC (FHWA-TS-80-218), February 1980.
- Harrington, Bruce W., Design and Construction of Infiltration Trenches, Seminar-Urban Watershed Management, How to Design Urban Stormwater Best Management Practices, ASCE, July, 1994.
- Hilding, Karen, A Survey of Infiltration Basins in the Puget Sound Regions, Masters Project, U. of California, 1993.
- Jacobson, Michael A., Summary and Conclusions from Applied Research on Infiltration Basins and Recommendations for Modifying the Washington Department of Ecology Stormwater Management Manual for the Puget Sound Basin. University of Washington, Center for Urban Water Resources Management. May 1993.
- King County, Washington, Surface Water Design Manual, September 1, 1998.
- Klochak, John R., An Investigation of the Effectiveness of Infiltration Systems in Treating Urban Runoff, Master of Science, U. of Washington, 1992.
- Konrad, C. P., Jensen, B. W., Burges, S. J, Reinelt, L. E. On-Site Residential Stormwater Management Alternatives. Center for Urban Water Resources, University of Washington. September 1995.
- Livingston, E. H., Infiltration Practices: The Good, the Bad, and the Ugly, National Conference on Urban Runoff Management, Chicago, Ill. 1993.
- Moore, John, Seepage: A System for Early Evaluation of the Pollution Potential of Agriculture Groundwater Environments, SCS, 1988.

- Pettyjohn, W.A., Introduction to Artificial Ground Water Recharge, USEPA, Ada, Oklahoma, National Waterwell Association, Worthington, Ohio, 1981, 44 p.
- Rawls, W. J., D. L. Brakensiek, and K. E. Saxton, Estimation of Soil Properties. Transactions of the American Society of Agricultural Engineers, Vol. 25, No. 5, pp. 1316-1320, 1982.
- Schueler, Thomas, et. al., A Current Assessment of Urban Best Management Practices, March, 1992
- Soil Conservation Service, SCS National Engineering Handbook Section 8, Engineering Geology , USDA., 1978.
- Soil Conservation Service, USDA, SCS National Engineering Handbook, Section 18 Ground Water, 1968.
- Soil Conservation Service, USDA, SCS Technical Release No. 36, Ground Water Recharge, Engineering Division, 1967, 22 p.
- Todd, D.K., Ground Water Hydrology, John Wiley and Sons, Inc., N.Y., 1959.
- Urbonas and Stahre, "Stormwater Best Management Practices", Prentiss-Hall, 1993
- WEF Manual of Practice #23 Urban Runoff Quality Management, Water Environment Federation & ASCE 1998.
- Wenzel, L.K., Methods of Determining Permeability of Water Bearing Materials, USGS Water Supply Paper 887, 1942.
- Wiltsie, Edward, Stormwater Facilities Performance Study, Infiltration Pond Testing and Data Evaluation, August 10, 1998
- Woodward-Clyde, BMP Design Recommendations, November 1995

# **City of Tacoma Surface Water Management Manual**

---

## **Volume IV Source Control BMPs**

Prepared by:

Tacoma Public Works  
Environmental Services

January 2003





# Table of Contents – Volume IV

---

<b>Chapter 1 – Introduction to Volume IV .....</b>	<b>1-1</b>
1.1    What is the Purpose of this Manual?.....	1-1
1.2    How Do I Know Whether Any of This Applies to Me?.....	1-1
1.3    What Type of Pollutants are we Targeting With This Manual? .....	1-1
1.4    What Are Best Management Practices (BMPs)? .....	1-4
1.4.1    Source Control BMPs .....	1-4
1.4.2    Treatment BMPs .....	1-4
1.5    Am I Exempted if I am Already Doing BMPs? .....	1-5
1.6    How Do I Get Started? .....	1-5
1.7    Some Important Requirements to Note .....	1-5
<b>Chapter 2 – Worksheets for Commercial and Industrial Activities.....</b>	<b>2-1</b>
Section A1 – Cleaning and Washing Activities.....	2-1
Section A2 – Transfers of Liquid or Solid Materials.....	2-1
Section A3 – Production and Application Activities .....	2-2
Section A4 – Storage Activities.....	2-3
Section A5 – Construction Activities .....	2-4
Section A6 – Dust Control and Soil and Sediment Control.....	2-4
Section A7 – Other Activities .....	2-4
<b>Chapter 3 – Best Management Practices for Single-Family Residences .....</b>	<b>3-1</b>
3.1    Automobile Washing .....	3-2
3.2    Automobile Maintenance.....	3-3
3.3    Storage of Solid Wastes and Food Wastes .....	3-4
3.4    Composting.....	3-5
3.5    Yard Maintenance and Gardening .....	3-6
3.6    Swimming Pool and Spa Cleaning and Maintenance .....	3-8
3.7    Household Hazardous Material Use, Storage and Disposal .....	3-8
<b>Chapter 4 – Best Management Practices for Commercial and Industrial Activities.....</b>	<b>4-1</b>
4.1    Begin with Chapter 2, Worksheet for Commercial and Industrial Activities .....	4-1
4.2    Explanation of Required BMPs .....	4-1
4.2.1    Stormwater Treatment.....	4-2
4.3    BMPs to Consider for All Activities .....	4-2

<b>Section A1 – Cleaning and Washing Activities .....</b>	<b>4-6</b>
A1.1 Cleaning or Washing of Tools, Engines and Manufacturing Equipment .	4-7
A1.2 Cleaning or Washing of Cooking Equipment.....	4-9
A1.3 Washing, Pressure Washing and Steam Cleaning of Vehicles/Equipment/Buildnig Structures.....	4-11
A1.4 Collection and Disposal of Wastewater in Mobile Interior Washing Operations .....	4-13
<b>Section A2 – Transfer of Liquid or Solid Materials .....</b>	<b>4-14</b>
A2.1 Loading and Unloading Areas for Liquid or Solid Material .....	4-15
A2.2 Fueling at Dedicated Stations .....	4-18
A2.3 Engine Repair and Maintenance.....	4-21
A2.4 Mobile Fueling of Vehicles and Heavy Equipment .....	4-23
<b>Section A3 – Production and Application Activities .....</b>	<b>4-26</b>
A3.1 Concrete and Asphalt Mixing and Production at Stationary Sites .....	4-27
A3.2 Concrete Pouring, Concrete Cutting, and Asphalt Appliation at Sites.....	4-29
A3.3 Manufacturing and Post-Processing of Metal Products .....	4-31
A3.4 Wood Treatment Areas.....	4-33
A3.5 Commercial Composting.....	4-35
A3.6 Landscaping and Lawn/Vegetation Management .....	4-37
A3.7 Painting, Finishing and Coating of Vehicles, Boats, Buildings and Equipment.....	4-43
A3.8 Commercial Printing Operations .....	4-45
A3.9 Manufacturing Operations – Outside.....	4-46
<b>Section A4 – Storage and Stockpiling Activites.....</b>	<b>4-52</b>
A4.1 BMPs for Storage or Transfer (Outside) of Solid Raw Materials, By- Products or Finished Products .....	4-48
A4.2 Storage and Treatment of Contaminated Soils .....	4-50
A4.3 Temporary Storage or Processing of Fruits or Vegetables.....	4-52
A4.4 Storage of Soild Wastes and Food Wastes.....	4-54
A4.5 Recyclers and Scrap Yards .....	4-56
A4.6 Treatment, Storage, or Disposal of Dangerous Wastes .....	4-57
A4.7 Storage of Liquid, Food Waste or Dangerous Waste Containers .....	4-58
A4.8 Storage of Liquids in Permanent Above-Ground Tanks .....	4-60
A4.9 Parking and Storage for Vehicles and Equipment.....	4-62
A4.10 Loading and Unloading Areas for Solid Material .....	4-63

<b>Section A5 – Construction and Demolition Activities.....</b>	<b>4-64</b>
A5.1 Clearing, Grading and Preparation of Construction Sites .....	4-65
A5.2 Demolition of Buildings .....	4-66
A5.3 Building Repair, Remodeling and Construction .....	4-67
<b>Section A6 – Dust Control and Soil and Sediment Control .....</b>	<b>4-69</b>
A6.1 BMPs for Dust Control at Disturbed Land Areas and Unpaved Roadways and Parking Lots .....	4-70
A6.2 Dust Control at Manufacturing Sites .....	4-72
A6.3 Soil Erosion and Sediment Control at Industrial Sites .....	4-73
<b>Section A7 – Other Activities.....</b>	<b>4-74</b>
A7.1 Commercial Animal Handling Areas .....	4-75
A7.2 Log Sorting and Handling .....	4-76
A7.3 Boat Building, Mooring, Maintenance and Repair .....	4-77
A7.4 Logging.....	4-79
A7.5 Mining and Quarrying of Sand, Gravel, Rock, Peat, Clay and Other Materials .....	4-81
A7.6 Swimming Pool and Spa Cleaning and Maintenance.....	4-82
A7.7 Deicing and Anti-Icing Operations for Airports and Streets .....	4-83
A7.8 Roof and Building Drains at Manufacturing and Commercial Building..	4-85
A7.9 Urban Streets .....	4-86
A7.10 Railroad Yards.....	4-88
A7.11 Maintenance of Public and Utility Corridors and Facilities .....	4-89
A7.12 Maintenance of Roadside Ditches .....	4-91
A7.13 Maintenance of Stormwater Drainage and Treatment Facilities .....	4-93
A7.14 Spills of Oil and Hazardous Substances .....	4-95
<b>Chapter 5 – Source Control Best Management Practices .....</b>	<b>5-1</b>
5.1 Index of BMP Descriptions.....	5-1
5.2 Source Control BMPs .....	5-2
BMP S.1 Eliminate Illicit Storm Drain Connections.....	5-2
BMP S.2 Dispose of Collected Runoff and Waste Materials Properly.....	5-4
BMP S.3 Connect Process Water Discharges to a Sanitary Sewer, Holding Tank, or Wastewater Treatment System .....	5-5
BMP S.4 Cover the Activity with a Roof or Awning.....	5-6
BMP S.5 Cover the Activity with an Anchored Tarp or Plastic Sheet.....	5-9
BMP S.6 Pave the Activity Area and Slope to a Sump or Holding Tank .....	5-10

BMP S.7 Surround the Activity Area with a Curb, Berm, or Dike, or Elevate the Activity.....	5-12
BMP S.8 Implement Integrated Pest Management Measures .....	5-14
BMP S.9 Cleaning Catch Basins.....	5-15
5.3 Treatment BMPs.....	5-16
<b>Chapter 6 – Regulations and Requirements .....</b>	<b>6-1</b>
6.1 City of Tacoma Codes and Ordinances.....	6-1
6.2 State, Federal, and Other Regulations and Requirements .....	6-1
R.1 Washington State Department of Ecology Requirements for the Discharge of Process Wastewaters Directly to Surface Waters.....	6-2
R.2 Washington State Department of Ecology Requirements for Dangerous Waste Generations .....	6-3
R.3 Washington State Department of Ecology Stormwater NPDES Permit Requirements .....	6-5
R.4 Ecology Requirements for Underground and Above Ground Storage Tanks .....	6-5
R.5 U.S. EPA and Washington State Department of Ecology Emergency Spill Cleanup Requirements.....	6-7
R.6 Washington State Department of Agriculture Pesticide Regulations .....	6-8
R.7 Puget Sound Air Pollution Control Agency Air Quality Regulations.....	6-9
R.8 Requirements of Native American Tribes .....	6-9
<b>Chapter 7 – Quick Reference Phone Numbers .....</b>	<b>7-1</b>
<b>References .....</b>	<b>Ref-1</b>
 <b>Appendices</b>	
Appendix IV-A	Recycling/Disposal of Vehicle Fluids/Other Wastes
Appendix IV-B	Example of an Integrated Pest Management Program
Appendix IV-C	Recommendations for Management of Street Wastes

## Figures

4.1	Uncovered Wash Area .....	4-97
4.2	Drip Pan .....	4-97
4.3	Drip Pan Within Rails.....	4-97
4.4	Loading Dock with Door Skirt .....	4-98
4.5	Loading Dock with Overhang.....	4-98
4.6	Covered Fuel Island .....	4-98
4.7	Enclose the Activity .....	4-98
4.8	Cover the Activity .....	4-98
4.9	Covered Storage Area for Bulk Solids (include berm if needed) .....	4-99
4.10	Material Covered with Plastic Sheeting.....	4-99
4.11	Secondary Containment System .....	4-99
4.12	Locking System for Drum Lid.....	4-100
4.13	Covered and Bermed Containment Area .....	4-100
4.14	Mounted Container .....	4-100
4.15	Above-Ground Tank Storage.....	4-101
5.1	Roofs & Awnings .....	5-14
5.2	Roofs & Awnings .....	5-15
5.3	Tarp Covering.....	5-16
5.4	Paved Area with Sump Drain.....	5-16
5.5	Containment Types .....	5-17

# Chapter 1 – Introduction to Volume IV

---

## 1.1 What is the Purpose of this Manual?

This manual was designed to help businesses, homeowners and public agencies in Tacoma implement source control best management practices (BMPs) to prevent pollutants from contaminating stormwater runoff and entering our rivers, lakes and streams. Human and ecosystem health, safety and welfare can be at risk from polluted stormwater. The implementation of BMPs is required by several programs, which are listed in 1.3 below. Every person/business in Tacoma is required to use BMPs. You need to select BMPs from this manual to prevent stormwater pollution. Refer to Section 1.4 below for additional information on BMPs. Information on stormwater treatment BMPs can be found in Volume I, Section 1.4 and Volume 5, particularly Chapter 2.

## 1.2 How Do I Know Whether Any of This Applies to Me?

Because of the provisions of the federal Clean Water Act and Coastal Zone Management Act, the National Pollutant Discharge Elimination System (NPDES) municipal stormwater permit, the Puget Sound Water Quality Authority Water Quality Management Plan, and Chapter 12.08 of the City Code of Tacoma, Sewage Disposal and Drainage Regulations and Rates, Including the Industrial Wastewater Pretreatment Program, the implementation of BMPs applies to all businesses, residences and public agencies in Tacoma. It includes all permanent and temporary activities at public facilities, commercial and industrial facilities, agriculture and livestock farms, and residential dwellings. Anyone involved in a particular activity, whether as an employee, supervisor, manager, landlord, tenant, or homeowner, must take part in implementing appropriate BMPs. BMPs need to be selected from this manual.

The City of Tacoma adopted the Regional Road Maintenance Endangered Species Act – Program Guidelines in 2002. This document was developed by the Tri-County Road Maintenance ESA Technical Working Group and contains guidelines for roadway maintenance operations, utility maintenance, maintenance of stormwater facilities, and other right-of-way (ROW) structure maintenance within the ROW. The goal of the Program Guidelines is to provide a consistent, regional program that can be used by any agency wishing to limit, reduce or eliminate the prohibition on take of threatened species under the 4(d) rule of the Federal Endangered Species Act. There is some overlap between this document, Volume IV of the Surface Water Management Manual, Source Control BMPs, and the above mentioned Program Guidelines. The Surface Water Management Manual, Volume IV Source Control BMPs are required as the minimum standard for source controls. The Regional Road Maintenance Manual may contain additional requirements above the Surface Water Management Manual minimum standards.

## 1.3 What Type of Pollutants are we Targeting With This Manual?

Under the NPDES permit mentioned above, the City is required to show progress in eliminating virtually all non-stormwater discharges to the storm drainage system. In other words, nothing but uncontaminated stormwater may be discharged to the City of Tacoma storm drainage system. There are severe state and federal penalties for anyone violating the terms of these permits. Illicit discharges may be intentional or unintentional, but either way are not allowed. **You must keep pollutants from leaving your property and entering the City storm drainage system.**

Pollutants can be placed into several broad categories. The descriptions provided below are quite brief, but further information on a particular pollutant can be obtained by calling one of the information numbers listed in Chapter 7.

### **pH**

The pH value of a substance gives you a relative measure of whether it is acidic or basic. The pH value of a body of water is vitally important, since most aquatic life can operate within a relatively narrow band of pH values (6 to 8). Some sources that can contribute to a change in pH of stormwater and waterbodies are cement in concrete pouring, paving and recycling operations, solutions from metal plating, chemicals from printing businesses and other industrial processes, and household cleaners such as bleaches and deck washes.

### **Total Suspended Solids**

This represents particulate solids such as eroded soil, heavy metal precipitates, and biological solids (all considered as conventional pollutants), which can cause sedimentation in streams and turbidity in receiving surface waters. These sediments can destroy the desired habitat for fish and can impact drinking water supplies. The sediment may be carried to streams, lakes, or Puget Sound where they may be toxic to aquatic life and make dredging necessary.

### **Oils and Greases**

Oils and greases can be either petroleum-based or food-related sources. Petroleum-based compounds can be immediately toxic to fish and wildlife, and if they reach our drinking water aquifers, will make us sick too. Food-based oils and greases may not be toxic to us, but they can coat fish gills and insects, and suffocate them.

### **Oxygen-demanding Substances**

Degradable organic matter, such as yard, food and pet wastes, and some chemical wastes, can have a drastic effect on water quality if they are allowed to enter stormwater. As these substances are broken down by bacteria, the oxygen in the water is consumed. This stresses and can eventually kill fish and other creatures in the water.

### **Metals**

Metals are utilized in many products important to our daily lives. Certain metals, known as heavy metals, wear off of our car brakes and tires, and come from the paint and moss-killing roof strips and herbicides we use at our homes. These metals can cause severe health and reproductive problems in fish and animals that live in water and sediments that become contaminated by runoff.

### **Bacteria and Viruses**

Bacteria and viruses from pet wastes, failing septic systems and agricultural areas can contaminate drinking water and close down swimming and shellfish areas. A group of bacteria called **fecal coliform bacteria** are typically used as the indicators for pollution by more serious disease-causing microorganisms. The Washington State Department of Ecology is proposing changes to the State Water Quality Standards that will become effective in 2003. The changes include the use of new bacterial indicators; E. Coli for fresh water and enterococci for marine water will replace fecal coliform bacteria, except that fecal coliform will still be used in marine waters that contain shellfish beds.

### **Nutrients**

In the context of water quality, nutrients are mainly compounds of nitrogen and phosphorus. When nutrients are allowed to enter waterbodies, undesirable effects such as algae overgrowth, oxygen depletion, channel clogging due to overgrowth of vegetation, and fish and animal death can occur. Sources of nutrients can include fertilizers, failing septic systems, and yard and animal wastes.

### **Toxic Organic Compounds**

A number of organic chemicals are just plain toxic when they get into the aquatic environment. Many pesticides, herbicides, rodenticides, and fungicides are deadly to aquatic life. The same is true of compounds such as antifreeze, wood preservatives, cleansers and a host of other, more exotic organics derived from industries or past practices (such as polychlorinated biphenyls (PCBs), DDT and chlordane).

### **Other Chemicals and Substances**

There are a host of other chemicals that can cause problems if allowed to enter the aquatic environment. Common household bleach can be deadly to fish and other critters if drained directly to waterbodies. Diatomaceous earth backwash from swimming pool filters can clog gills and suffocate fish. Arsenic has been used in rat and mole killing compounds. Even those compounds classified as **biodegradable or environmentally friendly** can have devastating **immediate** effects on aquatic life.



## 1.4 What Are Best Management Practices (BMPs)?

BMPs are a series of actions that are designed to reduce stormwater pollution. BMPs are separated into two broad categories, namely source control BMPs and treatment BMPs.

### 1.4.1 Source Control BMPs

As the name implies, source control BMPs prevent contamination from entering stormwater runoff by controlling them at the source. There are two categories of source control BMPs: operational and structural.

1. Operational source control BMPs are non-structural practices that prevent or reduce pollutants from entering stormwater. Examples include:
  - formation of a pollution prevention team,
  - good housekeeping practices,
  - preventive maintenance procedures,
  - spill prevention and cleanup,
  - employee training,
  - inspections of pollutant sources, and
  - record keeping.
  - They can also include process changes such as raw material/product changes and recycling wastes.

Operational source control BMPs are considered to be the most cost effective pollutant minimization practices.

2. Structural source control BMPs are physical, structural or mechanical devices or facilities that are intended to prevent pollutants from entering stormwater. Examples of structural source control BMPs typically include:
  - enclosing and/or covering the pollutant source, i.e., within a building or other enclosure, a roof over storage and working areas, a temporary tarp, etc.,
  - physically segregating the pollutant source to prevent run-on of uncontaminated stormwater,
  - devices that direct only contaminated stormwater to appropriate treatment BMPs, i.e., discharge to a sanitary sewer if allowed by the local sewer utility.

Structural BMPs typically cost more to construct, operate and maintain.

### 1.4.2 Treatment BMPs

Treatment BMPs are utilized to treat stormwater that is already contaminated. Most treatment BMPs require planning, designing, permitting and construction, and none can remove 100% of the contaminants in stormwater. These factors, added to the typical expense of treatment BMPs, makes source control BMPs the preferred choice.

There may, however, be some instances where treatment BMPs may be required. This volume identifies specific treatment BMPs that apply to particular pollutant sources, such as fueling stations, railroad yards, storage and transfer of materials, etc. After identifying the required treatment BMPs, the reader can refer to Volume I, Section 1.4 and Volume V of this manual for additional information about treatment BMPs.

## **1.5 Am I Exempted if I am Already Doing BMPs?**

Businesses already implementing BMPs in accordance with other federal, state, or local programs usually do not have to implement additional BMPs. Persons or businesses qualifying for exemptions include:

- Businesses required to obtain a general or individual National Pollutant Discharge Elimination System (NPDES) permit for stormwater discharges must comply with the requirements of that permit. See regulatory requirement R.2 in Chapter 6 of this manual for details.

If you are on the above list, the City assumes that you are implementing the appropriate BMPs. If the City finds that you have not implemented your BMPs, or that the BMPs that you have implemented are not effectively addressing the discharge of contaminants, then you may be required to enact additional BMPs to meet requirements. *Everyone* must do BMPs, but how each business goes about it, and through which government program, may differ from business to business.

## **1.6 How Do I Get Started?**

If you are a landlord, tenant or owner of a single-family residence, proceed to Chapter 3 for BMPs that are recommended for you.

If you own a business or industry, complete the worksheet in Chapter 2. If you checked off any of the activities as being performed outdoors, use the activity code on the worksheet to find the BMPs recommended for you in Chapter 4.

If you have questions, please contact the City's Stormwater Source Control Unit at (253) 591-5588. They can provide assistance over the phone and also at your business site.

## **1.7 Some Important Requirements to Note**

Under current state and local law, if you own commercial property and lease or rent it, you can be held responsible for water quality problems caused by your tenants. Make sure your tenants are informed of their responsibilities under the auspices of this manual.

Another important requirement is the need for an accidental spill plan if your business has the potential for a spill. If you are currently under a

Pretreatment permit for discharge to sewers, it will probably require a minor amount of effort to amend it to include stormwater. Please contact the City of Tacoma Source Control Unit at 253-591-5588 for information on developing these plans.

You are responsible for obtaining prior approval for your stormwater discharge to the City system. This means obtaining proper building and environmental permits from the City and State. Please contact the City of Tacoma Building and Land Use Services Division at 253-591-5030 or the Source Control Unit at 253-591-5588 for permit information. For State Department of Ecology permits, call 360-407-6400.

# Chapter 2 – Worksheets for Commercial and Industrial Activities

This worksheet is designed for use by business and industry operators. Complete the entire worksheet by checking the appropriate boxes for all activities that take place at your work place. If you checked off any of the activities as being performed outdoors, use the activity code on the worksheet to find the BMPs recommended for you in Chapter 4.

Activity Code	TYPE OF ACTIVITY	Are you involved in this? If so, check if it occurs:	
		INDOORS <sup>1</sup>	OUTDOORS <sup>2</sup>

SECTION A1 – CLEANING AND WASHING ACTIVITIES			
A1.1	Cleaning or washing of tools, engines and manufacturing equipment <ul style="list-style-type: none"> <li>This includes parts washers, and all types of manufactured equipment components.</li> </ul>		
A1.2	Cleaning or washing of cooking equipment <ul style="list-style-type: none"> <li>This includes vents, filters, pots and pans, grills, and related items.</li> </ul>		
A1.3	Washing, Pressure Washing and Steam Cleaning of Vehicles/Equipment/Building Structures <ul style="list-style-type: none"> <li>This covers cleaning and washing at all types of establishments, including fleet vehicle yards, car dealerships, car washes, and maintenance facilities.</li> </ul>		
A1.4	Collection and disposal of wastewater from mobile interior washing operations <ul style="list-style-type: none"> <li>This includes carpet cleaners, upholstery cleaners, and drapery cleaners.</li> </ul>		

SECTION A2 – TRANSFERS OF LIQUID OR SOLID MATERIALS			
A2.1	Loading and Unloading Areas for Liquid or Solid Material <ul style="list-style-type: none"> <li>Loading and unloading of materials at industrial and commercial facilities</li> </ul>		
A2.2	Fueling at dedicated stations <ul style="list-style-type: none"> <li>This includes gas stations, pumps at fleet vehicle yards or shops, and other privately owned pumps.</li> </ul>		
A2.3	Engine repair and maintenance <ul style="list-style-type: none"> <li>This covers oil changes and other engine fluids.</li> </ul>		
A2.4	Mobile fueling of vehicles and heavy equipment <ul style="list-style-type: none"> <li>Fleet fueling, wet fueling and wet hosing</li> </ul>		

Activity Code	TYPE OF ACTIVITY	Are you involved in this? If so, check if it occurs:	
		INDOORS <sup>1</sup>	OUTDOORS <sup>2</sup>

<b>SECTION A3 – PRODUCTION AND APPLICATION ACTIVITIES</b>			
A3.1	Concrete and asphalt mixing and production at stationary sites. <ul style="list-style-type: none"> <li>Applies to mixing of raw materials on-site to produce concrete or asphalt.</li> </ul>		
A3.2	Concrete pouring, concrete cutting, and asphalt application at temporary sites <ul style="list-style-type: none"> <li>This includes construction sites, and driveway and parking lot resurfacing.</li> </ul>		
A3.3	Manufacturing and post-processing of metal products <ul style="list-style-type: none"> <li>This includes machining, grinding, soldering, cutting, welding, quenching, rinsing, etc.</li> </ul>		
A3.4	Wood treatment areas <ul style="list-style-type: none"> <li>This includes wood treatment using pressure processes or by dipping or spraying.</li> </ul>		
A3.5	Commercial composting <ul style="list-style-type: none"> <li>Includes commercial composting facilities operating outside.</li> </ul>		
A3.6	Landscaping and vegetation management activities, including vegetation removal, herbicide and insecticide application, fertilizer application, irrigation, watering, gardening, and lawn care. <ul style="list-style-type: none"> <li>Includes businesses involved in landscaping, applying pesticides and in managing vegetation.</li> </ul>		
A3.7	Painting, finishing and coating of vehicles, boats, buildings and equipment. <ul style="list-style-type: none"> <li>Includes surface preparation and the applications of paints, finishes and/or coatings.</li> </ul>		
A3.8	Commercial printing operations <ul style="list-style-type: none"> <li>Includes materials used in the printing process.</li> </ul>		
A3.9	Manufacturing Activities – Outside <ul style="list-style-type: none"> <li>Includes outdoor manufacturing areas.</li> </ul>		

Activity Code	TYPE OF ACTIVITY	Are you involved in this? If so, check if it occurs:	
		INDOORS <sup>1</sup>	OUTDOORS <sup>2</sup>

SECTION A4 – STORAGE ACTIVITIES			
A4.1	Storage or transfer (outside) of solid raw materials, by-products or finished products		
A4.2	Storage and treatment of contaminated soils <ul style="list-style-type: none"> <li>This applies to contaminated soils that are excavated and left on-site.</li> </ul>		
A4.3	Temporary storage or processing of fruits or vegetables <ul style="list-style-type: none"> <li>This includes processing activities at wineries, fresh and frozen juice makers, and other food and beverage processing operations.</li> </ul>		
A4.4	Storage of solid wastes and food wastes <ul style="list-style-type: none"> <li>This includes regular garbage and all other discarded non-liquid items.</li> </ul>		
A4.5	Recyclers and scrap yards <ul style="list-style-type: none"> <li>This includes scrapped equipment, vehicles, empty metal drums, and assorted recyclables.</li> </ul>		
A4.6	Treatment, storage, or disposal of dangerous wastes. <ul style="list-style-type: none"> <li>Refer to Ecology and the Tacoma-Pierce County Health Department for more information, see Chapter 6.</li> </ul>		
A4.7	Storage of liquid, food waste or dangerous waste containers <ul style="list-style-type: none"> <li>This includes containers located outside a building and used for temporary storage</li> </ul>		
A4.8	Storage of liquids in permanent above-ground tanks <ul style="list-style-type: none"> <li>Includes all liquids in above-ground tanks</li> </ul>		
A4.9	Parking and storage for vehicles and equipment <ul style="list-style-type: none"> <li>Includes public and commercial parking lots</li> </ul>		
A4.10	Loading and unloading areas for solid materials <ul style="list-style-type: none"> <li>(Refer to A2.1 Loading and unloading areas for liquid and solid materials.</li> </ul>		

Activity Code	TYPE OF ACTIVITY	Are you involved in this? If so, check if it occurs:	
		INDOORS <sup>1</sup>	OUTDOORS <sup>2</sup>

<b>SECTION A5 – CONSTRUCTION ACTIVITIES</b>			
A5.1	Clearing, grading, and preparation of construction sites. <ul style="list-style-type: none"> <li>Applies to land developing activities and to residential yard clearing and grading projects.</li> </ul>		
A5.2	Demolition of buildings. <ul style="list-style-type: none"> <li>Applies to removal of existing buildings and subsequent clearing of the rubble.</li> </ul>		
A5.3	Building repair, remodeling and construction. <ul style="list-style-type: none"> <li>Applies to construction of buildings, general exterior building repair work and remodeling of buildings.</li> </ul>		

<b>SECTION A6 – DUST CONTROL AND SOIL AND SEDIMENT CONTROL</b>			
A6.1	Dust control at disturbed land areas and unpaved roadways and parking lots		
A6.2	Dust control at manufacturing sites <ul style="list-style-type: none"> <li>Includes grain dust, sawdust, coal, gravel, crushed rock, cement and boiler fly ash.</li> </ul>		
A6.3	Soil erosion and sediment control at industrial sites <ul style="list-style-type: none"> <li>Includes industrial activities that take place on soil.</li> </ul>		

<b>SECTION A7 – OTHER ACTIVITIES</b>			
A7.1	Commercial animal handling areas <ul style="list-style-type: none"> <li>This includes kennels, fenced pens, veterinarians and businesses that board animals</li> </ul>		
A7.2	Log sorting and handling <ul style="list-style-type: none"> <li>Applies to log yards typically located at sawmills, ports and pulp mills.</li> </ul>		
A7.3	Boat building, mooring, maintenance, and repair <ul style="list-style-type: none"> <li>This includes all types of maintenance, repair, and building operations.</li> </ul>		
A7.4	Logging <ul style="list-style-type: none"> <li>Applies to logging activities that fall under Class IV general forest practices.</li> </ul>		

Activity Code	TYPE OF ACTIVITY	Are you involved in this? If so, check if it occurs:	
		INDOORS <sup>1</sup>	OUTDOORS <sup>2</sup>
A7.5	Mining and quarrying of sand, gravel, minerals, peat, clay, rock, and other materials <ul style="list-style-type: none"> <li>This does not include excavation at construction sites.</li> </ul>		
A7.6	Swimming pool and spa cleaning and maintenance <ul style="list-style-type: none"> <li>This includes every swimming pool and spa not at a single family residence. Commercial pool cleaners are included here for all pools.</li> </ul>		
A7.7	Deicing and anti-icing operations for airports and streets <ul style="list-style-type: none"> <li>Includes aircraft, runways/taxiways, streets and highways.</li> </ul>		
A7.8	Roof and building drains at manufacturing and commercial buildings <ul style="list-style-type: none"> <li>These sites will be referred to the Puget Sound Clean Air Agency.</li> </ul>		
A7.9	Urban streets <ul style="list-style-type: none"> <li>Includes recommended BMPs.</li> </ul>		
A7.10	Railroad yards		
A7.11	Maintenance of public and private utility corridors and facilities <ul style="list-style-type: none"> <li>Includes public and private utility maintenance activities.</li> </ul>		
A7.12	Maintenance of roadside ditches		
A7.13	Maintenance of stormwater drainage and treatment facilities		
A7.14	Spills of oil and hazardous substances		

<sup>1</sup>If you checked off any of these activities as occurring **indoors** at your business, then you are exempt from implementing BMPs, provided no indoor drains or processes can ultimately contact stormwater or be transported to surface waters such as rivers, lakes and streams. You must ensure that liquids, powders, dusts and fine granular materials stay confined indoors, otherwise you will be subject to all of the BMP requirements.

<sup>2</sup>If you checked off any of these activities as occurring **outdoors** at your business, then use the activity code to find the appropriate BMPs described in Chapter 4.



## Chapter 3 – Best Management Practices for Single-Family Residences

---

The actions we take each day in and around our homes have a profound effect on surface water quality and fish habitat in this region. Stormwater goes directly to our lakes, streams and to Puget Sound. It does not go to the wastewater treatment plant. Any pollutants that get into the stormwater go directly to surface water. Small amounts of pollution from many different sources can significantly affect our waterways. Yard maintenance, waste storage, car washing and maintenance, and pool cleaning are some of the activities that can adversely impact water quality. The best management practices (BMPs) discussed in this section are practical ways to keep stormwater from becoming polluted in the first place. It is recommended that all residents in Tacoma use these BMPs. **Please note that some of these procedures are required by various state, or city laws, and are noted as required BMPs.**

Here's a general list of best management practices (BMPs) for citizens. The list includes brief information on applicability. For more information on the following BMPs, refer to the information in Sections 3.1 through 3.7 of this chapter.

### **Automobile Washing (3.1)**

**At Home:** Wash your car on grass or gravel. Use a nozzle on your hose. Use soaps and detergents that are biodegradable and that don't contain phosphates. Pour the bucket of dirty water down your sink so it goes to the wastewater treatment plant.

**Away from Home:** Use a commercial car wash or go to a fund raising car wash that uses a City of Tacoma Clean Bay Car Wash loaner kit. Reserve your own Clean Bay Car Wash loaner kit for your fundraising car wash.

### **Automobile Maintenance (3.2)**

Fix leaks. Recycle all oils, antifreeze, solvents, contaminated gasoline, and batteries. Don't mix wastes. Don't dump anything on the ground or down a storm drain!

### **Storage of Solid Wastes and Food Wastes (3.3)**

Recycle as much as you can. Purchase products which have the least amount of packaging material. Keep your waste area clean.

### **Composting (3.4)**

Locate compost piles on unpaved areas and away from wetlands, streams and drainage paths. Cover the compost pile.

### **Yard Maintenance and Gardening (3.5)**

Follow the exact directions when using pesticides, herbicides and fertilizers. Don't apply in the wind or when rain is expected. Don't apply within 100 feet of streams, lakes and wetlands. Use the City's curbside yard waste recycling program.

Consider “Green Gardening” practices such as using a mulching mower and mowing higher which helps improve soil/grass health and reduces the need for fertilizers and pesticides. Consider planting vegetation suited to the Northwest climate.

### **Swimming Pool and Spa Cleaning and Maintenance (3.6)**

Pool and spa water must be dechlorinated before the pool or spa is emptied, or else it must go to the sanitary sewer. Hire a professional pool service company for help if you need it. Store all hazardous materials out of the reach of children, and in a manner that prevents chemical reactions.

### **Household Hazardous Material, Use, Storage and Disposal (3.7)**

Recycle! Use the City’s Household Hazardous Waste facility located at the landfill. Store all hazardous materials out of the reach of children. Follow the manufactures’ directions for use of all materials.

## **3.1 Automobile Washing**

Most residents wash their cars in the driveway or on the street. Washwaters typically flow to a storm drain or ditch, which discharges stormwater directly to the nearest stream, lake or to Puget Sound. Soaps and detergents, even the biodegradable ones, can have immediate and long-term effects on critters living in waterbodies. The grime washed off the car also contains a variety of pollutants that can harm fish and wildlife.

### **Suggested BMPs**

#### **At Home:**

- Wash your car directly over your lawn or make sure the wash water drains to a vegetated area. This allows the water and soap to soak into the ground instead of running off into a local waterbody.
- Ideally, no soaps or detergents should be used, but if you do use one, select one without phosphates.
- Sweep driveways and street gutters **before** washing vehicle to clean up dirt, leaves, trash and other materials that may flow to the storm drain along with your wash water. This helps reduce storm drain maintenance costs as well as protect water quality.
- Commercial products are available that allow you to clean a vehicle without water. These were developed for areas where water is scarce, so a water saving benefit is realized as well as reduced pollution.
- Use a hose nozzle with a shut-off valve to save water.
- Do not wash your car if rain is expected.

- Pour the bucket of soapy, dirty washwater down your sink. This way the water doesn't pollute surface water. Instead, it's treated at the wastewater treatment plant.

**Away from Home:**

- Consider not washing your car at home. Take it to a commercial car wash that has a recycle system and discharges wastewater to the sanitary sewer for treatment.
- Go to fundraising car washes where sponsors use Tacoma's Clean Bay Car Wash loaner kits. Look for the Clean Bay Car Wash logo. Use a Clean Bay Car Wash loaner kit. If your group is planning a car wash in Tacoma, call 253-502-2120 to reserve a Clean Bay Car Wash loaner kit.

### **3.2 Automobile Maintenance**

Many of us are "weekend mechanics". We enjoy the cost savings of changing our own oil and antifreeze, topping off the battery with water, and generally making our car perform its' best. There is a lot of potential for stormwater pollution associated with these activities; however, the following BMPs will help you minimize pollution while servicing your car.

**Required BMPs**

- **Recycle all oils, antifreeze, solvents and batteries. Many local car parts dealers and gas stations accept used oil. The Household Hazardous Waste facility at the Tacoma Landfill accepts oil, oil filters, antifreeze and solvents. Old batteries can actually be worth money. Call shops listed under Batteries in the Yellow Pages of the phone book to find out if they are paying for used batteries. Use the numbers listed in Chapter 7 to call for more information.**
- **Never dump new or used automotive fluids or solvents on the ground, in a storm drain or street gutter, or in a waterbody. Eventually, it will make its way to local surface waters or groundwater, including the water we drink.**
- **Do not mix wastes. The chlorinated solvents in some carburetor cleaners can contaminate a huge tank of used oil, rendering it unsuitable for recycling. Always keep your wastes in separate containers which are properly labeled and store them out of the weather.**

**Suggested BMPs**

- Fix all leaks, to keep the leaky material off the streets and out of the surface water.

- To dispose of oil filters, punch a hole in the top and let drain for 24 hours. This is where a large funnel in the top of your oil storage container will come in handy. After draining, wrap in 2 layers of plastic and dispose of in your regular garbage or recycle by taking it to the Tacoma Landfill, Household Hazardous Waste facility. Pending State law may make disposal in your home garbage illegal, so please call the Hazardous Waste line at 1-800-287-6429 for up-to-date information.
- Use care in draining and collecting antifreeze to prevent accidental spills. Spilled antifreeze can be deadly to cats and dogs that ingest it.
- Perform your service activities on concrete or asphalt or over a plastic tarp to make spill clean-up easier. Keep a bag of kitty litter on hand to absorb spills. Sprinkle a good layer on the spill, let it absorb for a little while and then sweep it up. Place the contaminated litter in a plastic bag, tie it up, and dispose of it in your regular garbage. Take care not to leave kitty litter out in the rain; it will form a sticky goo that is hard to clean up.
- If you are doing body work outside, be sure to use a tarp to catch material resulting from grinding, sanding and painting. Dispose of this waste by double bagging in plastic and placing in your garbage.

### **3.3 Storage of Solid Wastes and Food Wastes**

Improper storage of food and solid waste at residences can lead not only to water pollution problems, but problems with neighborhood pets and vermin as well. Following the BMPs listed below can help keep your property a clean and healthy place to live.

#### **Suggested BMPs**

- All waste containers kept outside should have lids. If your lid is damaged, please call Tacoma Solid Waste Management at 591-5543 to get the lid repaired or replaced.
- Leaking waste containers should be replaced. If your container is damaged, please call Tacoma Solid Waste Management at 253-591-5543.
- Store waste containers under cover if possible, or on grassy areas.
- Use the Tacoma Call-2-Haul program to pick up bulky materials and excess waste material. Call 253-573-2468 for more information and details, or to set up an appointment for waste pickup.
- Inspect the storage area regularly to pick up loose scraps of material and dispose of them properly.

- Recycle as much as you can. Tacoma offers curbside recycling. Also, look under "Recycling" in the phone book for firms which take other recyclables.
- Purchase products which have the least amount of packaging materials.
- Compost biodegradable materials such as grass clippings and vegetable scraps instead of throwing them away. Your flowerbeds will love the finished compost, and we won't fill up our landfills so quickly. Call Tacoma Solid Waste Utility Recycling and Composting at 253-565-5955 for more information on composting. See the section on Composting for BMPs relating to that activity.
- A fun alternative to traditional composting is worm composting. You can let worms do all the work for you by keeping a small vermiculture box just outside your kitchen. For more information on getting started with worms, call the number listed above.

### **3.4 Composting**

Composting is an earth-friendly activity as long as some common sense rules outlined below are followed. If you choose to compost, the following BMPs should be utilized.

#### **Suggested BMPs**

- Compost piles must be located on an unpaved area where runoff can soak into the ground or be filtered by grass and other vegetation. Compost piles should be located in an area of your yard not prone to water ponding during storms, and should be kept well away from wetlands, streams, lakes and other drainage paths.
- Compost piles must be maintained and turned over regularly to work properly. Large piles of unattended compost may create odor and vermin problems.
- Avoid putting hazardous or non-decomposable waste in the pile.
- Cover the compost pile for two reasons:
  1. To keep stormwater from washing nutrients into waterways.
  2. To keep excess water from cooling down the pile, which will slow down the rate of decomposition.
- Build bins of wood, chicken wire or fencing material to contain compost so it can't be washed away. Call Tacoma Solid Waste Utility Recycling and Composting at 565-5955 to get free composter designs and materials lists.

- Building a small earthen dike around your compost pile is an effective means of preventing nutrient-rich compost drainage from reaching stormwater paths.

### 3.5 Yard Maintenance and Gardening

This section deals with the normal yard maintenance activities we all perform at our homes. Overwatering, overfertilizing, improper herbicide application and improper disposal of trimmings and clippings can all contribute to serious water pollution problems. Following the BMPs listed below will help alleviate pollutant runoff.

#### Required BMPs

- **Follow the manufacturer's directions exactly for mixing and applying herbicides, fungicides and pesticides, and use them sparingly. Never apply when it is windy or when rain is expected. Never apply over water, within 100 feet of a well-head, or adjacent to streams, wetlands, or other waterbodies. Triple-rinse empty containers, using the rinsate for mixing your next batch of spray, and then double-bag and dispose of the empty container in your regular garbage. Never dispose of grass clippings or other vegetation in or near storm drains, streams, lakes or Puget Sound.**

#### Suggested BMPs

- Use natural, organic soil amendments like Tacoma's TAGRO Mix. TAGRO Mix is a 100% recycled blend of de-watered, Class A, "Exceptional Quality" biosolids, mixed with sawdust and sand. The excellent soil conditioning properties of the organic matter aid water retention in lighter soils and help to break up and aerate heavier soils, so roots can grow better and less watering is needed. It contains both readily available and long term nitrogen and other nutrients commonly lacking in Northwest soils. The slow release of nitrogen better matches the needs of plants. Thus, there is much less potential for nitrates to leach into surface or ground water due both to less "excess nitrogen" and also less water use. Better vegetative growth can also reduce erosion and runoff.
- Use an integrated pest management program (IPM), which is a natural, long-term, ecologically based approach to controlling pest populations. See Chapter 4, Activity A3.6 Landscaping and Lawn/Vegetation Management and Appendix IV-B Example of an Integrated Best Management Program.
- Follow manufacturer's directions when applying fertilizers. More is not better, either for your lawn or for local waterbodies. Never apply fertilizers over water or adjacent to ditches, streams or other water

bodies. Remember that organic fertilizers have a slow release of nitrogen, and less potential to pollute than synthetic fertilizers.

- Save water and prevent pollution problems by watering your lawn sensibly. Lawns and gardens typically need the equivalent of 1" of rainfall per week. You can check on how you're doing by putting a wide mouth jar out where you're sprinkling, and measure the water with a small plastic ruler. Overwatering to the point of runoff can carry polluting nutrients to the nearest waterbody.
- Consider planting a vegetated buffer zone adjacent to streams or other water bodies on your property. Call the Pierce County Conservation District at 253-845-2973 for advice and assistance in developing a planting plan. The Stream Team at the Conservation District may even be able to help you plant it!
- Reduce the need for pesticides and fertilizers on lawns by improving the health of the soil. Aeration, thatching and topdressing with compost will improve soil health and help wanted grasses compete with weeds and moss.
- Make sure all fertilizers and pesticides are stored in a covered location. Rain can wash the labels off of bottles and convert 50 lbs. of fertilizer into either a solid lump or a river of nutrients.
- Use a mulching mower and mow higher to improve soil/grass health and to reduce or eliminate pesticide use.
- Compost all yard clippings, or use them as mulch to save water and keep down weeds in your garden. See Composting section for more information.
- Practice organic gardening and virtually eliminate the need to use pesticides and fertilizers. Contact Pierce County Cooperative Extension at 591-7180 or the Ask-A-Master Gardener program at 591-7170 for information and classes on earth-friendly gardening.
- Pull weeds instead of spraying and get some healthy exercise, too. If you must spray, use the least toxic formulations that will get the job done. The Master Gardener program listed above can help advise you on which spray to use.
- Work fertilizers into the soil instead of letting them lie on the ground surface exposed to the next rain storm.
- Plant vegetation suited to Northwest conditions because they require less water and fewer to no fertilizers and pesticides.
- Tacoma has a curbside yard waste recycling program. Call 253-565-5955 for more information.

### **3.6 Swimming Pool and Spa Cleaning and Maintenance**

Despite the fact that we immerse ourselves in it, the water from pools and spas is far from chemically clean. Nutrients, pH, and chlorine can adversely affect fish and wildlife in waterbodies. Following these BMPs will ensure the cleanliness of your pool and the environment.

#### **Required BMPs**

- **Pool and spa water must be dechlorinated if it is to be emptied into a ditch, on the ground, or a lawn or to the storm drainage system. Contact your pool chemical supplier to obtain the neutralizing chemicals you will need. The rate of flow into the ditch or drainage system must be regulated so that it does not cause problems such as erosion, surcharging or flooding. Water discharged to the ground or a lawn must not cross property lines and must not produce runoff.**
- **If pool and spa water cannot be dechlorinated, it must be discharged to the sanitary sewer. Prior to draining, your local wastewater treatment plant must be notified to ensure they are aware of the volume of discharge and the potential effects of chlorine levels. A pool service company can help you determine the frequency of cleaning and backwash of filters.**
- **Diatomaceous earth used in pool filters cannot be disposed of in surface waters, on the ground, into storm drainage systems or septic systems. Dry it out as much as possible, bag it in plastic, and dispose of at the landfill.**

#### **Suggested BMPs**

- Hire a professional pool service company to collect all pool water for proper disposal. Make sure to ask them where they will dispose of it and the kind of permits they hold to do so.

### **3.7 Household Hazardous Material Use, Storage and Disposal**

Once we really start looking around our houses, the amount of hazardous materials we have on site is a real eye-opener. Oil-based paints and stains, paint thinner, gasoline, charcoal starter fluid, cleaners, waxes, pesticides, fingernail polish remover, and wood preservatives are just a few that most of us have around the house.

When products such as these are dumped on the ground or in a storm drain, they can be washed directly to receiving waters where they can harm fish and wildlife. They can also infiltrate into the ground and contaminate drinking water supplies. The same problem can occur if they



are disposed of with your regular garbage; the containers can leak at the landfill and contaminate groundwater. The same type of contamination can occur if hazardous products are poured down a sink or toilet into a septic system. Don't pour them down the drain if you're on municipal sewers, either. Many compounds will "pass through" the wastewater treatment plant without treatment and contaminate receiving waters, or they can harm the biological process used at the treatment plant, reducing overall treatment efficiency.

With such a diversity of hazardous products present in all homes in Tacoma, a large potential for serious environmental harm exists if improper methods of storage, usage and disposal are employed. Using the following BMPs will help keep these materials out of our soils, sediments and waters.

### **Required BMPs**

- **Hazardous materials must be stored out of the reach of children. Never transfer to or store these materials in food or beverage containers which could be misinterpreted by a child as something to eat or drink.**
- **Dispose of hazardous materials and their containers properly. Never dump products labeled as *poisonous, corrosive, caustic, flammable, inflammable, volatile, explosive danger, warning, caution or dangerous* outdoors, in a storm drain, or into sinks, toilets or drains. Call the Household Hazardous Waste Facility at (253) 591-5418 or the Hazardous Waste Line at 1-800-287-6429 for information on disposal methods, collection events, and alternative products. Household hazardous wastes from City of Tacoma residents are accepted at the Tacoma Landfill.**

### **Suggested BMPs**

- Check hazardous material containers frequently for signs of leakage. If a container is rusty and has the potential of leaking soon, place it in a secondary container before the leak occurs and prevent a clean-up problem.
- Store hazardous materials containers under cover and off the ground. Keep them out of the weather to avoid rusting, freezing, cracking, labels being washed off, etc.
- Keep appropriate spill cleanup materials on hand. Kitty litter is good for many oil-based spills.
- Ground cloths and drip pans must be used under any work outdoors which involves hazardous materials such as oil-based paints, stains, rust removers, masonry cleaners, and others bearing label warnings as outlined above.

- Latex paints are not a hazardous waste, but are not accepted in liquid form at the landfill. To dispose, leave uncovered in a protected place until dry, then place in the garbage. If you wish to dry waste paint quickly, just pour kitty litter in the can to absorb the paint. Once paint is dry, leave the lid off when you place it in the garbage so your garbage collector can see that it is no longer liquid.
- Use less toxic products whenever possible. The Hazardous Waste Line at 1-800-287-6429, and the Washington Toxics Coalition at 206-632-1545 have information detailing alternatives to toxic products.
- If an activity involving the use of a hazardous material can be moved indoors out of the weather, then do so. Make sure you can provide proper ventilation, however.
- Follow manufacturers' directions in the use of all materials. Over-application of yard chemicals, for instance, can result in the washing of these compounds into receiving waterbodies. Never apply pesticides when rain is expected.
- When hazardous materials are in use, place the container inside a tub or bucket to minimize spills.
- Purchase only the amount of product that's needed.

# Chapter 4 – Best Management Practices for Commercial and Industrial Activities

---

## 4.1 Begin with Chapter 2, Worksheet for Commercial and Industrial Activities

This chapter coordinates with the worksheet that you completed in Chapter 2. That worksheet and the BMPs are organized by the different activities that businesses perform. If you perform the listed activity indoors, controlling all discharges from the activity (e.g., process water, wash water, lubricants, solvents, fugitive dust, granular material, blowdown waste, etc.) such that no exposure to stormwater occurs, then you do not have to institute new BMPs for that activity. However, if you checked the column for activities performed outdoors, match the number from the worksheet to the activities listed in this section to find the suggested BMPs you should utilize.

If you have questions, please contact the City's Stormwater Source Control Unit at 253-591-5588. They can provide assistance over the phone and are also available for consultations at your business site.

## 4.2 Explanation of Required BMPs

**Every person/business in Tacoma is required to use BMPs.** You need to select BMPs from this manual. The required BMPs are in **bold** text. Please note that in some instances there are required BMPs that are mandated by various federal, state, or city laws. You are encouraged to utilize additional BMPs to further protect our water quality. For instance, if only one BMP is required, you may wish to couple it with another BMP to prevent pollution from ever getting into stormwater in the first place.

Some businesses are or will be required to obtain a National Pollutant Discharge Elimination System (NPDES) permit for stormwater discharges. These permits are issued and regulated by the Washington State Department of Ecology. Businesses that are regulated under the NPDES stormwater program are exempt from implementing the BMPs outlined in this manual, since they will be implementing BMPs required by the state. Refer to Volume I, Section 1.6.5 and Section 6.5 of this Volume for more information about NPDES permits for industries.

The BMPs outlined in this manual are focused on source control: that is, using methods to prevent pollution from ever getting into stormwater in the first place. Many of these BMPs are common sense and "housekeeping" issues. For instance, you can sweep an indoor or outdoor work area instead of hosing it into a storm drain or other drainage conveyance. The use of source control BMPs is always the first line of defense in stormwater pollution prevention efforts for several reasons:

- In the majority of cases, source control BMPs are all that is needed to correct stormwater pollution problems.
- Most source control BMPs are relatively inexpensive and easy to implement.
- Treatment BMPs are utilized after pollution has entered stormwater. These BMPs are expensive, and can never remove 100% of the pollution in stormwater. It is far better to use source control BMPs where possible and prevent the pollution in the first place. This volume identifies specific treatment BMPs that apply to particular pollutant sources, such as fueling stations, railroad yards, storage and transfer of materials, etc. Additional information about treatment BMPs are found in Volume V of this manual.

(NOTE: At times, the type of pollutants present or the condition of a site could mean treatment BMPs are required.)

The minimum requirements for stormwater source control are contained in Volume I, Minimum Technical Requirements and Site Planning, Chapter 3, Section 3.5.3 Minimum Requirement #3 Source Control of Pollution. In accordance with this minimum requirement, all known, available and reasonable source control BMPs shall be applied to all projects. Chapter 5 of this volume contains details on many source control BMPs, with references to appropriate documents for others.

#### **4.2.1 Stormwater Treatment**

Stormwater treatment may also be required for certain types of businesses, based on the information provided in this volume and in Volume I, Minimum Technical Requirements and Site Planning, Chapter 3, Minimum Requirements for New Development and Redevelopment, Section 3.5.6 Minimum Requirement #6 Runoff Treatment and in Volume 5, Runoff Treatment BMPs. Volume 5, Runoff Treatment BMPs, contains detailed information about stormwater treatment BMPs.

### **4.3 BMPs To Consider for all Activities**

Before we get to the list of activity specific BMPs, here is a summary of items that each business should consider. As stated before, most of these are common sense, housekeeping types of solutions, but if each business would take some action on each of these, the improvement in water quality would be substantial.

#### **1. Avoid the activity or reduce its occurrence**

If you can, avoid the activity or do it less frequently. Is there a substitute process or a different material you can use to get the job done? Can you do a larger run of a process at one time, thus reducing the number of times per week or month it needs to be repeated? For instance, raw

materials could be delivered close to the time of use instead of being stockpiled and exposed to the weather. Perhaps you could avoid one solvent-washing step altogether. The City's Source Control staff, the Department of Ecology or the Tacoma-Pierce County Health Department can provide pollution prevention assistance.

## **2. Move the activity indoors**

Sometimes it is fairly easy to move an activity indoors out of the weather. The benefits of this are twofold; you prevent runoff contamination, and you provide for easier, more controlled cleanup if a spill occurs. An example would be unloading and storing barrels of chemicals inside a garage area instead of doing it outside. Please be aware that moving storage areas indoors may require installation of fire suppression equipment or other building modifications as required by the Uniform Building Code, the Uniform Fire Code, or local ordinances.

## **3. Spills**

Promptly contain and clean up solid and liquid pollutant leaks and spills including oils, solvents, fuels, and dust from manufacturing operations on any exposed soil, vegetation, or paved area.

## **4. Use less material**

Don't buy or use more material than you really need. This not only helps keep potential disposal, storage and pollution problems to a minimum, but will probably save you money, too.

## **5. Use the least toxic materials available**

Investigate the use of materials that are less toxic than what you use now. Perhaps a caustic-type detergent or a solvent could be replaced with a more environmentally friendly product. Such a change might allow you to discharge process water to the sanitary sewer instead of paying for expensive disposal (contact the Tacoma Sanitary Source Control Unit at 253-591-5588 to find out about allowable sanitary discharges and pretreatment permits). Remember that even if you do switch to a biodegradable product, nothing but uncontaminated water is allowed to enter the storm drain system.

## **6. Create and maintain vegetated areas near activity locations**

Vegetation of various kinds can help filter pollutants out of stormwater, so it is advisable to route stormwater through vegetated areas located near your activity. For instance, many parking lots contain grassy islands, typically formed in a "hump". By creating those islands as depressions instead of humps, they can be used to treat runoff from the parking lot or roof. For high use sites, conveyance to an oil removal system may be required. For more information on high use sites, refer to Volume I,

Section 4.2, Step V, Step 2. Also, don't forget the erosion control benefits of vegetation at your site.

### **7. Locate activities as far as possible from surface drainage paths**

Activities located as far as possible from known drainage paths, ditches, streams, other waterbodies, and drains will be less likely to pollute, since it will take longer for material to reach the drainage feature. This gives you more time to react in the event of a spill, or if it is a "housekeeping" issue, may protect the local waters long enough for you to clean up the area around the activity. Don't forget that groundwater issues are always prominent, no matter where the activity is located, so the actions taken on your site on a day-to-day basis are always important, even in dry weather.

### **8. Keep storm drain systems clean**

Pollutants can concentrate over time in storm drainage structures such as catch basins, ditches and storm drains. When a large storm event occurs, it can mobilize these pollutants and carry them to receiving waters. Develop and implement maintenance practices, inspections, and schedules for treatment devices (e.g., detention ponds, oil/water separators, vegetated swales, etc.). Requirements for cleaning catch basins will be discussed later in the *specific BMP S.9*.

### **9. Reduce, reuse and recycle as much as possible**

Always look for ways to recycle instead of just disposing. This can save money as well as keep both hazardous and non-hazardous materials out of the landfills. You can learn more about other businesses that have made process changes allowing recycling of chemicals by calling the DOE at 1-800-RECYCLE and requesting publication #92-45 and 90-22. Another unique recycling opportunity for businesses is available through the Industrial Materials Exchange (IMEX). This free service acts as a waste or surplus "matchmaker", helping one company's waste become another company's asset. For instance, waste peach pits from a cannery become potpourri ingredients to another business. Call IMEX at 206-625-6232 to list your potentially usable solid or chemical waste in their publication.

### **10. Be an advocate for stormwater pollution prevention**

Help friends, partners and business associates find ways to reduce stormwater pollution in their activities. Most people want clean water, and do not pollute intentionally. Share your ideas and the BMPs in this manual to get them thinking about how their everyday activities affect water quality.

## **11. Report violators**

Allowing anyone to pollute our water resources is wrong. We all must do our part to protect water, fish, wildlife and our own health, by employing proper BMPs, and reporting those who are causing pollution. Call the City of Tacoma's Source Control Unit at 253-591-5588 to report incidents involving sewers or storm drains.

## **12. Oversight and Training**

Assign one or more individuals to be responsible for stormwater pollution control. Hold regular meetings to review the overall operation of the BMPs. Establish responsibilities for inspections, operation and maintenance, and availability for emergency situations. Train all team members in the operation, maintenance and inspections of BMPs, and reporting procedures.

## **13. Dust Control**

Sweep paved material handling and storage areas regularly as needed, for the collection and disposal of dust and debris that could contaminate stormwater. Do not hose down pollutants from any area to the ground, storm drain, conveyance ditch, or receiving water unless necessary for dust control purposes to meet air quality regulations and unless the pollutants are conveyed to a treatment system approved by the City.

## **14. Maintenance**

- Clean oils, debris, sludge, etc. from all BMP systems regularly, including catch basins, settling/detention basins, oil/water separators, boomed areas, and conveyance systems, to prevent the contamination of stormwater.
- Promptly repair or replace all substantially cracked or otherwise damaged paved secondary containment, high-intensity parking and any other drainage areas, which are subjected to pollutant material leaks or spills.
- Promptly repair or replace all leaking connections, pipes, hoses, valves, etc. which can contaminate stormwater.

Maintenance standards can be found in Volume 3, Chapter 3 and in Volume 5, Chapter 4 of this manual.

**SECTION A1**  
**CLEANING AND WASHING ACTIVITIES**



## **A1.1 CLEANING OR WASHING OF TOOLS, ENGINES AND MANUFACTURING EQUIPMENT**

**Description of Pollutant Sources:** This activity applies to businesses and public agencies that clean manufacturing equipment such as saws, grinders, screens, and other processing devices outside of buildings, and to businesses engaged in pressure washing of engines, equipment and portable objects.

Pollutants sources include toxic hydrocarbons, organic compounds, oils and greases, nutrients, heavy metals, pH, suspended solids, biochemical oxygen demand (BOD), and chemical oxygen demand (COD).

**Pollutant Control Approach:** The preferred approach is to cover and/or contain the cleaning activity, or conduct the activity inside a building, to separate the uncontaminated stormwater from the pollutant sources. Washwater must be conveyed to a sanitary sewer after approval by the City of Tacoma, temporarily stored before proper disposal, or recycled, with no discharge to the ground, to a storm drain, or to surface water. Washwater may be discharged to the ground after proper treatment in accordance with *Ecology guidance WQ-R-95-56, "Vehicle and Equipment Washwater Discharges," June 1995*. The quality of any discharge to the ground after proper treatment must comply with Ecology's Ground Water Quality Standards, Chapter 173-200 WAC. Contact the local Ecology Regional Office for an NPDES Permit application for discharge of washwater to surface water or to a storm drain after on-site treatment.

### **Required BMPs**

**The following BMPs, or equivalent measures, are required of all businesses and public agencies engaged in cleaning or washing of tools, engines, equipment and portable objects:**

- **Illicit connections to the storm drainage system must be eliminated. See BMP S.1 in Chapter 5 for detailed information.**
- **Employees should be educated to control washing operations to prevent stormwater contamination.**
- **All washwater must discharge to a holding tank, process treatment system, or sanitary sewer, never to the storm drain system. See BMP S.3 in Chapter 5 for detailed information on how this must be accomplished.**
- **Pressure washing must be done in a designated area (such as a wash pad) provided with a sump drain and stormwater run-on prevention. See BMPs S.6 and S.7 in Chapter 5 for information on sumps (or holding tanks) and run-on prevention. Contact the Tacoma Sanitary Source Control Unit at 591-5588 for washing operation policy.**

## Recommended BMPs

The following BMPs are not required, but they can provide additional pollution control:

- If soaps or detergents are used, use the least toxic cleaner capable of doing the job. Use non-phosphate detergent, if possible, to reduce loadings at your local wastewater treatment plant.
- Limit the amount of water used in washing activities to reduce the potential of runoff carrying pollutants beyond the designated wash pad or capture system.
- Recycle wash water for subsequent washings.
- Implement one or more of the following stormwater treatment BMPs in addition to the Required BMPs:
  - Oil/water separator (Do not use an oil/water separator for washwaters containing soaps or detergents.)
  - Wet vault for settling.
  - Infiltration basin.
  - Filtration with media designed for the pollutants present.
  - Catch basin with a filter insert for pressure washing to collect suspended solids.
- Catch basin filters and/or sorbent inserts should be selected based on the type of contaminants in the stormwater.

For discharging washwaters containing soaps and detergents, the use of infiltration, biofiltration, wet ponds and wetlands must not result in the violation of groundwater quality standards.

## **A1.2 CLEANING OR WASHING OF COOKING EQUIPMENT**

**Description of Pollutant Sources:** This activity applies to businesses that clean cooking equipment such as vent filters, grills and grease traps outside of buildings.

Pollutants of concern consist of oil and grease, nutrients, suspended solids, biochemical oxygen demand (BOD) and chemical oxygen demand (COD)

**Pollutant Control Approach:** Businesses engaged in this activity that cannot connect discharges to a sanitary sewer, holding tank, or process water treatment system must contact the Department of Ecology and obtain a National Pollutant Discharge Elimination System (NPDES) wastewater permit.

### **Required BMPs**

The following BMPs or equivalent measures are required of all businesses engaged in cleaning or washing of cooking equipment:

- **Illicit connections to the storm drainage system must be eliminated. See BMP S.1 in Chapter 5 for detailed requirements.**
- **Employees must be educated about the need to prevent stormwater contamination from washing operations.**
- **Washwater cannot be discharged to the storm drainage system.**
- **Paved washing areas must be swept daily to collect loose solid materials for proper disposal.**
- **Greasy buildup on cooking equipment must be removed and properly disposed of prior to washing to reduce the amount of material that can potentially contaminate runoff.**
- **Move the activity indoors, either in an existing building or in a newly constructed building or shed, with drainage to a sanitary sewer, holding tank, or process treatment system. See BMP S.3 in Chapter 5 for further information on drainage alternatives. Any connection to the sanitary sewer requires the approval of the Tacoma Sanitary Source Control Unit at 591-5588.**

**OR**

**Use a tub or similar device to contain washwater. This water must be recycled for subsequent washing, or disposed into a holding tank or sanitary sewer.**

**OR**

**If the washing activity cannot be moved indoors or contained in a tub, then the washing area must drain to a sanitary sewer, holding tank, or process treatment system, and provisions must be made to prevent stormwater run-on onto the washing area. See BMP S.3 in Chapter 5 for detailed drainage requirements, and BMP S.7 for**

**run-on prevention schemes. If discharging to a sanitary sewer, permits must be obtained from the Tacoma Sanitary Source Control Unit at (253) 591-5588.**

- **If a holding tank is used for storage of washwater, the contents must be pumped out before it is full and disposed of appropriately to a sanitary sewer or wastewater treatment system.**

### **Recommended BMPs**

The following BMPs are not required, but they can provide additional pollution protection:

- A cover should be placed over a designated wash area to keep rain from falling on dirty equipment and producing contaminated runoff.
- Implement one or more of the following treatment BMPs in addition to the required BMPs:
  - Oil/water separator.
  - Wet vault for settling.
  - Infiltration basin with pretreatment.
  - Filtration with media designed for the pollutants present.

For discharging washwaters containing soaps and detergents, the use of infiltration, biofiltration, wet ponds and wetlands must not result in the violation of groundwater quality standards.

### **A1.3 WASHING, PRESSURE WASHING AND STEAM CLEANING OF VEHICLES/EQUIPMENT/BUILDING STRUCTURES**

**Description of Pollutant Sources:** Vehicles, aircraft, vessels, carpet cleaning, and industrial equipment, and large buildings may be commercially cleaned with low or high pressure water or steam. This includes frequent “charity” car washes at gas stations and commercial parking lots. The cleaning can include hand washing, scrubbing, sanding, etc. Washwater from cleaning activities can contain oil and grease, suspended solids, heavy metals, soluble organics, soaps, and detergents that can contaminate stormwater.

**Pollutant Control Approach:** The preferred approach is to cover and/or contain the cleaning activity, or conduct the activity inside a building, to separate the uncontaminated stormwater from the pollutant sources. Washwater must be conveyed to a sanitary sewer after approval by the City of Tacoma, temporarily stored before proper disposal, or recycled, with no discharge to the ground, to a storm drain, or to surface water. Washwater may be discharged to the ground after proper treatment in accordance with *Ecology guidance WQ-R-95-56, “Vehicle and Equipment Washwater Discharges,” June 1995*. The quality of any discharge to the ground after proper treatment must comply with Ecology’s Ground Water Quality Standards, Chapter 173-200 WAC. Contact the local Ecology Regional Office for an NPDES Permit application for discharge of washwater to surface water or to a storm drain after on-site treatment.

#### **Required BMPs:**

**Conduct vehicle/equipment washing in one of the following locations:**

- **At a commercial washing facility in which the washing occurs in an enclosure and drains to the sanitary sewer, or**
- **In a building constructed specifically for washing of vehicles and equipment, which drains to a sanitary sewer.**

**Conduct outside washing operation in a designated wash area with the following features:**

- **In a paved area, constructed as a spill containment pad to prevent the run-on of stormwater from adjacent areas. Slope the spill containment area so that washwater is collected in a containment pad drain system with perimeter drains, trench drains or catchment drains. Size the containment pad to extend out a minimum of four feet on all sides of the vehicles and/or equipment being washed.**
- **Convey the washwater to a sump (like a grit separator) and then to a sanitary sewer (if allowed by the City of Tacoma), or other appropriate wastewater treatment or recycle system. An NPDES permit may be required for any washwater discharge to a storm drain or receiving water after treatment. Contact the Ecology regional office for NPDES Permit requirements.**
- **The containment sump must have a positive control outlet valve for spill control with live containment volume, and oil/water separation. Size the minimum live storage volume to contain the maximum expected daily washwater flow plus the sludge storage volume below the outlet pipe. The outlet valve will be shut**

*Note that the purpose of the valve is to convey only washwater and contaminated stormwater to a treatment system.*

during the washing cycle to collect the washwater in the sump. The valve should remain shut for at least two hours following the washing operation to allow the oil and solids to separate before discharge to a sanitary sewer. (See Ecology Publication WQ-R-95-56)

- The inlet valve in the discharge pipe should be closed when washing is not occurring, thereby preventing the entry of uncontaminated stormwater into the pretreatment/treatment system. The stormwater can then drain into the conveyance/discharge system outside of the wash pad (essentially bypasses the washwater treatment/conveyance system). Post signs to inform people of the operation and purpose of the valve. Clean the concrete pad thoroughly until there is no foam or visible sheen in the washwater prior to closing the inlet valve and allowing uncontaminated stormwater to overflow and drain off the pad (see Figure 4.1).
- Collect the washwater from building structures and convey it to appropriate treatment such as a sanitary sewer system if it contains oils, soaps, or detergents, where feasible. If the washwater does not contain oils, soaps, or detergents then it could drain to soils that have sufficient natural attenuation capacity for dust and sediment.

#### **Recommended Additional BMPs:**

- The wash area should be well marked at gas stations, multi-family residences and any other business where non-employees wash vehicles.
- For uncovered wash pads, the positive control outlet valve may be manually operated, but a pneumatic or electric valve system is preferable. The valve may be on a timer circuit where it is opened upon completion of a wash cycle. The timer would then close the valve after the sump or separator is drained (Figure 4.1).
- Use phosphate-free biodegradable detergents when practicable.
- Consider recycling the washwater.
- Because soluble/emulsifiable detergents can be used in the wash medium, the selection of soaps and detergents and treatment BMPs should be considered carefully. Oil/water separators are ineffective in removing emulsified or water soluble detergents.

#### **Exceptions**

- At commercial parking lots, where it is not possible to discharge the washwater to a sanitary sewer, a temporary plug or a temporary sump pump can be used at the storm drain to collect the washwater for off-site disposal such as to a nearby sanitary sewer.
- Charity car washes are not allowed to discharge dirty wash water to the storm drain. Prior to holding a charity car wash, contact the City of Tacoma for information about proper car washing procedures and to find out about utilizing a Clean Bay Car Wash loaner kit.
- New and used car dealerships may wash vehicles in the parking stalls as long as a temporary plug system is used to collect the washwater for disposal as stated above, or an approved treatment system for the washwater is in place.

At industrial sites contact the local Ecology Regional Office for NPDES Permit requirements even if soaps, detergents, and/or other chemical cleaners are not used in washing trucks.

## **A1.4 COLLECTION AND DISPOSAL OF WASTEWATER IN MOBILE INTERIOR WASHING OPERATIONS**

**Description of Pollutant Sources:** This activity applies to businesses that wash carpets and other interior items on a mobile site-to-site basis. The typical fleet washing process includes use of machines that spray the washwater solution onto the carpet or upholstery and then suck the dirty solution up into a portable tank with limited capacity.

Pollutants of concern consist of nutrients, suspended solids, organic compounds (such as pesticides and chemicals used for flea and odor control), biochemical oxygen demand (BOD), and chemical oxygen demand (COD).

**Pollutant Control Approach:** Common practice in the past was to discharge the dirty solution onto the ground or to a drain connected to the storm drainage system between site visits. ***These practices are now illegal. Wastewater must be poured into a sanitary sewer drain at the site of collection, the business office, or at another proper location. If sanitary sewer disposal is not available or not allowed, the collected wastewater must be returned to the business site for process treatment or transfer to a holding tank.***

### **Required BMPs**

**This BMP is required of all businesses doing mobile interior wash activities:**

- **Absolutely no wastewater from mobile interior wash activities can be disposed of outdoors, or to a drain connected to the storm drainage system. This point must be made clear to all employees. Wastewater from mobile washing operations may be permitted for sanitary sewer disposal if it does not contain high concentrations of toxic materials. Some of the chemicals used for flea and odor control are listed by EPA as toxics. The Tacoma Sanitary Source Control Unit at 591-5588 will need to know the type of chemicals and amount of water you intend to discharge. If the discharge is approved, they will then issue a permit for your activity. Wastewater must be poured into a sanitary sewer drain at the site of collection, the business office, or at another proper location.**

**If sanitary sewer disposal is not available or not allowed, the collected wastewater must be returned to the business site for process treatment or transfer to a holding tank. See BMP S.3 in Chapter 5 for details on these drainage/disposal alternatives.**

### **Recommended BMPs**

The following BMPs are not required, but can provide additional pollution protection:

- Use the least toxic detergents and cleaners that will get the job done. Select non-phosphate detergents when possible.
- Limit the amount of water used in interior washing operations. This will save you time, money and effort when it comes to proper disposal.
- Recycle washwater for more than one use.

**SECTION A2**  
**TRANSFER OF LIQUID OR SOLID MATERIALS**



## **A2.1 LOADING AND UNLOADING AREAS FOR LIQUID OR SOLID MATERIAL**

**Description of Pollutant Sources:** Loading/unloading of liquid and solid materials at industrial and commercial facilities are typically conducted at shipping and receiving, outside storage, fueling areas, etc. Materials transferred can include products, raw materials, intermediate products, waste materials, fuels, scrap metals, etc. Leaks and spills of fuels, oils, powders, organics, heavy metals, salts, acids, alkalis, etc. during transfer are potential causes of stormwater contamination. Spills from hydraulic line breaks are a common problem at loading docks.

**Pollutant Control Approach:** Cover and contain the loading/ unloading area where necessary to prevent run-on of stormwater and runoff of contaminated stormwater.

### **Required BMPs**

#### ***At All Loading/ Unloading Areas:***

- **A significant amount of debris can accumulate at outside, uncovered loading/unloading areas. Sweep these surfaces frequently to remove material that could otherwise be washed off by stormwater. Sweep outside areas that are covered for a period of time by containers, logs, or other material after the areas are cleared.**
- **Place drip pans, or other appropriate temporary containment device, at locations where leaks or spills may occur such as hose connections, hose reels and filler nozzles. Drip pans shall always be used when making and breaking connections (see Figure 4.2). Check loading/ unloading equipment such as valves, pumps, flanges, and connections regularly for leaks and repair as needed.**

#### **At Tanker Truck and Rail Transfer Areas to Above/Below-ground Storage Tanks:**

- **To minimize the risk of accidental spillage, prepare an "Operations Plan" that describes procedures for loading/unloading. Train the employees, especially fork lift operators, in its execution and post it or otherwise have it readily available to employees.**
- **Report spills of reportable quantities to Ecology (refer to Chapter 7 for telephone numbers of Ecology Regional Offices).**
- **Prepare and implement an Emergency Spill Cleanup Plan for the facility (BMP Spills of Oil and Hazardous Substances) which includes the following BMPs:**
  - **Ensure the clean up of liquid/solid spills in the loading/ unloading area immediately, if a significant spill occurs, and, upon completion of the loading/unloading activity, or, at the end of the working day.**
  - **Retain and maintain an appropriate oil spill cleanup kit on-site for rapid cleanup of material spills. (See BMP A7.14 Spills of Oil and Hazardous Substances).**
  - **Ensure that an employee trained in spill containment and cleanup is present during loading/unloading.**

#### **At Rail Transfer Areas to Above/below-ground Storage Tanks:**

- **Install a drip pan system as illustrated (see Figure 4.3) within the rails to collect spills/leaks from tank cars and hose connections, hose reels, and filler nozzles.**

#### **Loading/Unloading from/to Marine Vessels:**

- **Facilities and procedures for the loading or unloading of petroleum products must comply with Coast Guard requirements.**

#### **Transfer of Small Quantities from Tanks and Containers:**

- **Refer to BMPs A4.8 Storage of Liquids in Permanent Above-Ground Tanks, and A4.7 Storage of Liquid, Food Waste, or Dangerous Waste Containers, for requirements on the transfer of small quantities from tanks and containers, respectively.**

#### **At All Loading/ Unloading Areas:**

- **Consistent with Uniform Fire Code requirements and to the extent practicable, conduct unloading or loading of solids and liquids in a manufacturing building, under a roof, or lean-to, or other appropriate cover.**
- **Berm, dike, and/or slope the loading/unloading area to prevent run-on of stormwater and to prevent the runoff or loss of any spilled material from the area.**
- **Large loading areas frequently are not curbed along the shoreline. As a result, stormwater passes directly off the paved surface into surface water. Place curbs along the edge, or slope the edge such that the stormwater can flow to an internal storm drain system that leads to an approved treatment BMP.**
- **Pave and slope loading/unloading areas to prevent the pooling of water. The use of catch basins and drain lines within the interior of the paved area must be minimized as they will frequently be covered by material, or they should be placed in designated “alleyways” that are not covered by material, containers or equipment.**

#### **Recommended BMPs:**

- **For the transfer of pollutant liquids in areas that cannot contain a catastrophic spill, install an automatic shutoff system in case of unanticipated off-loading interruption (e.g. coupling break, hose rupture, overfill, etc.).**

#### **At Loading and Unloading Docks:**

- **Install/maintain overhangs, or door skirts that enclose the trailer end (see Figures 4.4 and 4.5) to prevent contact with rainwater.**
- **Design the loading/unloading area with berms, sloping, etc. to prevent the run-on of stormwater.**

- Retain on-site the necessary materials for rapid cleanup of spills.

**At Tanker Truck Transfer Areas to Above/Below-Ground Storage Tanks:**

- Pave the area on which the transfer takes place. If any transferred liquid, such as gasoline, is reactive with asphalt pave the area with Portland cement concrete.
- Slope, berm, or dike the transfer area to a dead-end sump, spill containment sump, a spill control (SC) oil/water separator, or other spill control device. The minimum spill retention time should be 15 minutes at the greater flow rate of the highest fuel dispenser nozzle through-put rate, or the peak flow rate of the 6-month, 24-hour storm event over the surface of the containment pad, whichever is greater. The volume of the spill containment sump should be a minimum of 50 gallons with an adequate grit sedimentation volume.

## **A2.2 FUELING AT DEDICATED STATIONS**

**Description of Pollutant Sources:** A fueling station is a facility dedicated to the transfer of fuels from a stationary pumping station to mobile vehicles or equipment. It includes above or underground fuel storage facilities. In addition to general service gas stations, fueling may also occur at 24-hour convenience stores, construction sites, warehouses, car washes, manufacturing establishments, port facilities, and businesses with fleet vehicles. Typically, stormwater contamination at fueling stations is caused by leaks/spills of fuels, lube oils, radiator coolants, and vehicle washwater.

**Pollutant Control Approach:** Fueling stations must be constructed on an impervious concrete pad under a roof to keep out rainfall and stormwater run-on. A treatment BMP must be used for contaminated stormwater and wastewaters in the fueling containment area.

**For new or substantially remodeled Fueling Stations:**

**Required BMPs:**

- **Prepare an emergency spill response and cleanup plan (per BMP A7.14 Spills of Oil and Hazardous Substances) and have designated trained person(s) available either on site or on call at all times to promptly and properly implement that plan and immediately cleanup all spills. Keep suitable cleanup materials, such as dry adsorbent materials, on site to allow prompt cleanup of a spill.**
- **Train employees on the proper use of fuel dispensers. Post signs in accordance with the Uniform Fire Code (UFC). Post “No Topping Off” signs (topping off gas tanks causes spillage and vents gas fumes to the air). Make sure that the automatic shutoff on the fuel nozzle is functioning properly.**
- **The person conducting the fuel transfer must be present at the fueling pump during fuel transfer, particularly at unattended or self-serve stations.**
- **Keep drained oil filters in a suitable container or drum.**
- **Design the fueling island to control spills (dead-end sump or spill control separator in compliance with the UFC), and to treat collected stormwater and/or wastewater to required levels. Slope the concrete containment pad around the fueling island toward drains; either trench drains, catch basins and/or a dead-end sump. The slope of the drains shall not be less than 1 percent (Section 7901.8 of the UFC). Drains to treatment shall have a shutoff valve, which must be closed in the event of a spill. The spill control sump must be sized in compliance with Section 7901.8 of the UFC; or**
- **Design the fueling island as a spill containment pad with a sill or berm raised to a minimum of four inches (Section 7901.8 of the UFC) to prevent the runoff of spilled liquids and to prevent run-on of stormwater from the surrounding area. Raised sills are not required at the open-grate trenches that connect to an approved drainage-control system.**
- **The fueling pad must be paved with Portland cement concrete, or equivalent. Asphalt is not considered an equivalent material.**

- The fueling island must have a roof or canopy to prevent the direct entry of precipitation onto the spill containment pad (see Figure 4.6). The roof or canopy should, at a minimum, cover the spill containment pad (within the grade break or fuel dispensing area) and preferably extend several additional feet to reduce the introduction of windblown rain. Convey all roof drains to storm drains outside the fueling containment area.
- Stormwater collected on the fuel island containment pad must be conveyed to a sanitary sewer system, if approved by the City of Tacoma; or to an approved treatment system such as an oil/water separator and a basic treatment BMP. (Basic treatment BMPs are listed in Volume V and include media filters and biofilters) Discharges from treatment systems to storm drains or surface water or to the ground must not display ongoing or recurring visible sheen and must not contain greater than a significant amount of oil and grease.
- Alternatively, stormwater collected on the fuel island containment pad may be collected and held for proper off site disposal.
- Conveyance of any fuel-contaminated stormwater to a sanitary sewer must be approved by the City of Tacoma and must comply with pretreatment regulations (WAC 173-216-060). These regulations prohibit discharges that could cause fire or explosion. An explosive or flammable mixture is defined under state and federal pretreatment regulations, based on a flash point determination of the mixture. If contaminated stormwater is determined not to be explosive, then it could be conveyed to a sanitary sewer system.
- Transfer the fuel from the delivery tank trucks to the fuel storage tank in impervious contained areas and ensure that appropriate overflow protection is used. Alternatively, cover nearby storm drains during the filling process and use drip pans under all hose connections.

**Additional BMP for Vehicles 10 feet in height or greater:**

A roof or canopy may not be practicable at fueling stations that regularly fuel vehicles that are 10 feet in height or greater, particularly at industrial or WSDOT sites. At those types of fueling facilities, the following BMPs apply, as well as all of the other required BMPs and fire prevention (UFC) requirements.

- If a roof or canopy is impractical the concrete fueling pad must be equipped with emergency spill control, which includes a shutoff valve for the drainage from the fueling area. The valve must be closed in the event of a spill. An electronically actuated valve is preferred to minimize the time lapse between spill and containment. Spills must be cleaned up and disposed off-site in accordance with BMP A7.14 Spills of Oil and Hazardous Substances.
- The valve may be opened to convey contaminated stormwater to a sanitary sewer, if approved by the City of Tacoma, or to oil removal treatment such as an API or CP oil/water separator, catch basin insert, or equivalent treatment, and then to a basic treatment BMP. Discharges from treatment systems to storm drains or surface water

**or to the ground must not display ongoing or recurring visible sheen and must not contain greater than a significant amount of oil and grease.**

**An explosive or flammable mixture is defined under state and federal pretreatment regulations, based on a flash point determination of the mixture. If contaminated stormwater is determined not to be explosive or flammable then it could be conveyed to a sanitary sewer system.**

## **A2.3 ENGINE REPAIR AND MAINTENANCE**

**Description of Pollutant Sources:** This activity applies to businesses and public agencies where fuel filters, engine oil and other fluids such as battery acid, coolants and transmission and brake fluids are removed and replaced in vehicles and equipment. It also applies to mobile vehicle maintenance operations, such as at construction sites. Related vehicle maintenance activities are covered under the following activity headings in this manual:

- A1.3 Washing, Pressure Washing and Steam Cleaning of Vehicles/Equipment/Building Structures**
- A2.2 Fueling at Dedicated Stations**
- A3.4 Painting, Finishing and Coating of Vehicles, Products and Equipment**
- A7.3 Vehicle and Equipment Parking and Storage**

Pollutants of concern include toxic hydrocarbons, toxic organic compounds, oils and greases, pH and heavy metals.

**Pollutant Control Approach:** Control of leaks and spills of fluids using good housekeeping and cover and containment BMPs.

### **Required BMPs**

The following BMPs or equivalent measures are required of all businesses and agencies engaged in engine and vehicle repair:

- **Employees must be educated about the need for careful handling of automotive fluids. Employees at businesses or agencies who routinely change or handle these fluids must be trained in spill response and cleanup procedures.**
- **Spill cleanup materials, such as rags and absorbent materials, must always be kept close at hand when changing oil and other fluids. You can comply more easily with sewer and stormwater requirements by running a 'dry shop', thereby reducing your consumption/discharge of liquids. Soiled rags and other cleanup material must be properly disposed of or cleaned and reused.**
- **No drains inside maintenance buildings may connect to either the sanitary sewer or the storm drainage system without prior approval.**
- **Do not hose down the maintenance/repair area. Instead, sweep the area weekly to collect dirt, and wipe up spills with rags and other absorbent materials.**
- **If the work is done at a mobile location, such as a construction site, a tarp, ground cloth or drip pans must be used beneath the vehicle or equipment to capture all spills and drips. The collected drips and spills must be recycled or disposed of properly. See BMP S.2 in Chapter 5 for disposal options.**
- **If this activity occurs at a stationary business location, the activity area must be moved indoors. An exception to this requirement would be equipment that is too large to fit under a roofed area. In this case, the outdoor area must be paved, provided with a sump drain and provision made for stormwater run-on prevention. See BMP S.6 and S.7 in Chapter 5 for more on paving, sump drains and holding tanks,**

**and run-on prevention. Contact the Tacoma Sanitary Source Control unit at 591-5588 for information on requirements for disposal to sewer. If you are on a septic tank, sump contents will need to be pumped and disposed of by an oil recycler or hazardous waste company.**

- **Recycle oil, antifreeze, batteries, and air conditioning coolant.**
- **Implement the following treatment BMP in addition to the Required BMPs:**
  - **An oil/water separator or other appropriate treatment, if soluble components are present, should be used to treat all runoff from the fluid changing area.**

### **Recommended BMPs**

The following BMPs are not required, but can provide additional pollution prevention.

- Drain all fluids, from wrecked vehicles and 'parts' cars/equipment upon arrival. Recover air conditioning gases.
- Use reusable cloth rags to clean up drips and small spills instead of disposables: these can be professionally laundered and reused. Do not attempt to launder these at home or at a coin-op laundry.
- Use absorbent pillows or booms in or around storm drains and catch basins to absorb oil and fuel.



## **A2.4 MOBILE FUELING OF VEHICLES AND HEAVY EQUIPMENT**

**Description of Pollutant Sources:** Mobile fueling, also known as fleet fueling, wet fueling, or wet hosing, is the practice of filling fuel tanks of vehicles by tank trucks that are driven to the yards or sites where the vehicles to be fueled are located. Mobile fueling is only conducted using diesel fuel, as mobile fueling of gasoline is prohibited. Diesel fuel is considered as a Class II Combustible Liquid, whereas gasoline is considered as a Flammable Liquid.

Historically mobile fueling has been conducted for off-road vehicles that are operated for extended periods of time in remote areas. This includes construction sites, logging operations, and farms. Mobile fueling of on-road vehicles is also conducted commercially in the State of Washington.

**Pollutant Control Approach:** Proper training of the fueling operator, and the use of spill/drip control and reliable fuel transfer equipment with backup shutoff valving are typically needed.

### **Required BMPs**

**Organizations and individuals conducting mobile fueling operations must implement the following BMPs.**

**The operating procedures for the driver/operator should be simple, clear, effective and their implementation verified by the organization that will potentially be liable for environmental and third party damage.**

- **Ensure that all mobile fueling operations are approved by the Tacoma Fire Department and comply with local and Washington State fire codes.**
- **In fueling locations that are in close proximity to sensitive aquifers, designated wetlands, wetland buffers, or other waters of the State, approval by the City of Tacoma is necessary to ensure compliance with additional local requirements.**
- **Ensure the compliance with all 49 CFR 178 requirements for DOT 406 cargo tanker. Documentation from a Department of Transportation (DOT) Registered Inspector shall be proof of compliance.**
- **Ensure the presence and the constant observation/monitoring of the driver/operator at the fuel transfer location at all times during fuel transfer and ensure that the following procedures are implemented at the fuel transfer locations:**
  - **Locating the point of fueling at least 25 feet from the nearest storm drain or inside an impervious containment with a volumetric holding capacity equal to or greater than 110 percent of the fueling tank volume, or covering the storm drain to ensure no inflow of spilled or leaked fuel. Storm drains that convey the inflow to a spill control separator approved by the City of Tacoma, including the Tacoma Fire Department need not be covered. Potential spill/leak conveyance surfaces must be impervious and in good repair.**

- Placement of a drip pan, or an absorbent pad under each fueling location prior to and during all dispensing operations. The pan (must be liquid tight) and the absorbent pad must have a capacity of 5 gallons. Spills retained in the drip pan or the pad need not be reported.
- The handling and operation of fuel transfer hoses and nozzle, drip pan(s), and absorbent pads as needed to prevent spills/leaks of fuel from reaching the ground, storm drains, and receiving waters.
- Not extending the fueling hoses across a traffic lane without fluorescent traffic cones, or equivalent devices, conspicuously placed so that all traffic is blocked from crossing the fuel hose.
- Removing the fill nozzle and cessation of filling when the automatic shut-off valve engages. Do not allow automatic shutoff fueling nozzles to be locked in the open position.
- Not “topping off” the fuel receiving equipment
- Provide the driver/operator of the fueling vehicle with:
  - Adequate flashlights or other mobile lighting to view fill openings with poor accessibility. Consult with the Tacoma Fire Department for additional lighting requirements.
  - Two-way communication with his/her home base.
- Train the driver/operator annually in spill prevention and cleanup measures and emergency procedures. Make all employees aware of the significant liability associated with fuel spills.
- The fueling operating procedures should be properly signed and dated by the responsible manager, distributed to the operators, retained in the organization files, and made available in the event an authorized government agency requests a review.
- Ensure that the Tacoma Fire Department (911) and the appropriate regional office of the Department of Ecology are immediately notified in the event of any spill entering the surface or ground waters. Establish a “call down list” to ensure the rapid and proper notification of management and government officials should any significant amount of product be lost off-site. Keep the list in a protected but readily accessible location in the mobile fueling truck. The “call down list” should also pre-identify spill response contractors available in the area to ensure the rapid removal of significant product spillage into the environment.
- Maintain a minimum of the following spill clean-up materials in all fueling vehicles, that are readily available for use:
  - Non-water absorbents capable of absorbing 15 gallons of diesel fuel;
  - A storm drain plug or cover kit;

- **A non-water absorbent containment boom of a minimum 10 feet in length with a 12-gallon absorbent capacity;**
- **A non-metallic shovel; and,**
- **Two, five-gallon buckets with lids.**
  
- **Use automatic shutoff nozzles for dispensing the fuel. Replace automatic shut-off nozzles as recommended by the manufacturer.**
- **Maintain and replace equipment on fueling vehicles, particularly hoses and nozzles, at established intervals to prevent failures.**
- **Automatic fuel transfer shut-off nozzles; and,**
- **An adequate lighting system at the filling point.**

**SECTION A3**  
**PRODUCTION AND APPLICATION ACTIVITIES**

### **A3.1 CONCRETE AND ASPHALT MIXING AND PRODUCTION AT STATIONARY SITES**

**Description of Pollutant Sources:** This activity applies to businesses and agencies that mix raw materials onsite to produce concrete or asphalt. It also applies to subsequent uses such as pouring concrete structures and making other concrete or asphalt products. Mobile concrete pouring and asphalt application are covered under **Activity A3.2** in this section. Requirements for stockpiling of raw materials are covered under **Activity A4.1 Storage or Transfer (outside) of solid raw materials, by-products or finished products.**

Pollutants of concern include toxic hydrocarbons, toxic organic compounds, oils and greases, heavy metals and pH.

**Pollutant Control Approach:** Cover and contain processes where possible and prevent stormwater run-on and contamination, where feasible.

Any facility categorized under SIC Code 2951 or SIC Code 3273 may need to comply with Ecology's Sand and Gravel General Permit. Contact Ecology at (360) 407-6400 for additional information.

#### **Required BMPs**

**The following BMPs or equivalent measures are required of all businesses and public agencies active in concrete and asphalt mixing and production:**

- **Eliminate all illicit connections to the storm drainage system. See BMP S.1 in Chapter 5 for a detailed discussion on identifying and eliminating these connections.**
- **All process water from production, pouring and equipment cleaning must be discharged to a dead-end sump, process water treatment system or sanitary sewer, or recycled. Never wash fresh concrete or concrete mixer washout into streets, storm drainage systems, streams or other water bodies.**
- **A BMP maintenance schedule must be established, and employees educated about the need to prevent stormwater contamination through the use and proper maintenance of BMPs.**
- **Production and pouring areas must be protected from stormwater run-on. See BMP S.7 in Chapter 5 for methods of run-on protection.**
- **Cover the production area for prevention of stormwater run-on. See BMP S.4 and S.7 for information on covers and run-on prevention.**
- **Use absorbent materials or catch basin filters in and around storm drains and catch basins to filter out contaminants. See Volume V of this Manual, Runoff Treatment BMPs for more information about absorbent materials and catch basin filters.**

## Recommended BMPs

The following BMPs are not required, but can provide additional pollution protection:

- The production and pouring area should be swept at the end of each work day to collect loose chunks of aggregate and raw materials for recycling or proper disposal. See BMP S.2 in Chapter 5 for disposal options.
- Sweep all driveways and gutters that show accumulation of materials to minimize the amount that could be carried offsite by rain and enter the storm drainage system.
- Asphalt plants should use an oil/water separator to treat stormwater runoff. See Volume V of this Manual, Runoff Treatment BMPs for more information.
- Pave the mixing, production and pouring areas. A sump drain in these areas is probably not advisable due to potential clogging problems, but could be used in a curing area. Sweep these areas to remove loose aggregate and recycle or dispose of properly.
- Use storm drain covers or similarly effective containment devices to prevent runoff from entering the storm drainage system. Accumulations of dirty runoff must be disposed of properly.

Contact the City Surface Water Source Control Unit at 253-591-5588 for information about water quality treatment BMPs for these types of operations. Contact the Department of Ecology's web page for accepted water quality treatment at <http://www.ecy.wa.gov/programs/wq/stormwater/index.html>.

The use of any treatment BMP must not result in the violation of groundwater, surface water, or drinking water standards.

### **A3.2 CONCRETE POURING, CONCRETE CUTTING, AND ASPHALT APPLICATION AT TEMPORARY SITES**

**Description of Pollutant Sources:** This activity applies to businesses and public agencies that apply asphalt or pour or cut concrete for building construction and remodeling, road construction, sidewalk, curb and gutter repairs and construction, sealing of driveways and roofs, and other applications. These activities are typically done on a temporary site-to-site basis where permanent BMP measures do not apply. Concrete pouring activities can not only severely alter the pH of receiving waters, but slurry from aggregate washing can harden in storm pipes, thus reducing capacity and creating flooding problems.

Pollutants of concern include toxic hydrocarbons, toxic organic compounds, oils and greases, heavy metals, suspended solids and pH.

**Pollutant Control Approach:** Train employees on proper procedures, sweep or shovel aggregate chunks, collect accumulated runoff and solids, and wash equipment in designated areas.

#### **Required BMPs**

**The following BMPs or equivalent measures are required of all businesses and agencies doing concrete pouring and asphalt application at temporary sites:**

- **Employees must be educated on the pollution hazards of concrete and asphalt application and cutting.**
- **Loose aggregate chunks and dust must be swept or shoveled and collected (not hosed down a storm drain) for recycling or proper disposal at the end of each work day, especially at work sites such as streets, driveways, parking lots, sidewalks, curbs and gutters where rain can readily pick up the loose material and carry it to the nearest stormwater conveyance. Small amounts of excess concrete, grout and mortar can be disposed of in the trash.**
- **Storm drain covers or similarly effective containment devices must be placed over all nearby drains at the beginning of each day. Shovel or vacuum slurry and remove from the site. All accumulated runoff and solids must be collected and properly disposed (see BMP S.2 in Chapter 5 for disposal options) at the end of each work day, or more often if necessary.**
- **Exposed aggregate washing, where the top layer of unhardened concrete is hosed or scraped off to leave a rough finish, must be done with a mechanism for containment and collection of the discarded concrete slurry (such as the storm drain covers mentioned above). The easiest way to contain the washwater will be to direct the washings to a hole in the ground where the water can percolate into the ground and the solids later covered with soil.**
- **If directed to a drain, a catch basin filter insert must be used to remove the solids. This is especially useful if the activity must proceed on rainy days. See Volume V of this Manual, Runoff Treatment BMPs for more information about catch basin filter inserts.**

- **Cleaning of concrete application and mixing equipment or concrete vehicles on the work site must be done in a designated area where the rinse water is controlled. The rinse water must either be collected for proper disposal or put into a hole in the ground where the water can percolate away and the solids later covered with soil or recovered and disposed or recycled.**

**The use of any treatment BMP must not result in the violation of groundwater, surface water, or drinking water quality standards.**

### **Recommended BMPs**

The following BMPs are not required but can provide additional pollution prevention:

- Avoid the activity when rain is occurring or expected.
- If possible, portable asphalt mixing equipment should be covered by an awning, a lean-to or other simple structure to avoid contact with rain. See BMP S.4 in Chapter 5 for further details on cover structures.
- Recycle broken concrete and asphalt. Look under Recycling Services in the Yellow pages of the phone book to find the recycler nearest you.



### **A3.3 MANUFACTURING AND POST-PROCESSING OF METAL PRODUCTS**

**Description of Pollutant Sources:** This activity applies to businesses such as mills, foundries, and fabricators that manufacture or post-process metal products. A variety of activities such as machining, grinding, soldering, cutting, welding, quenching, cooling and rinsing may take place. These businesses may be required to obtain a National Pollutant Discharge Elimination System (NPDES) permit from the Department of Ecology. See Chapter 6 for a discussion of NPDES requirements. Note: Painting, finishing and coating of metal products is covered under **A3.10 Painting, Finishing and Coating of Vehicles, Boats, Buildings and Equipment**.

Pollutants of concern include toxic organic compounds, heavy metals, oils and greases, pH, suspended solids, and chemical oxygen demand (COD).

**Pollutant Control Approach:** Cover and contain operations and apply good housekeeping and preventive maintenance practices to prevent the contamination of stormwater.

#### **Required BMPs**

The following BMPs or equivalent measures are required of all businesses engaged in metals manufacturing or post-processing:

- **Eliminate illicit connections to the storm drainage system. See BMP S.1 in Chapter 5 for detailed information on identifying and eliminating illicit connections.**
- **Process wastewater (including contact cooling water, filter backwash, cooling tower blowdown, etc.) from this activity, and stormwater runoff from activity areas, must discharge to a sanitary sewer, holding tank, or process treatment system that would need an Ecology NPDES Permit for discharge to surface water or storm drain. Contact the Tacoma Sanitary Source Control Unit at 591-5588 to obtain permits for discharge to the sewer. See BMP S.3 in Chapter 5 for detailed requirements.**
- **Employees must be educated to control their work with metal products to minimize pollution.**
- **The activity area must be swept at the end of each work day to collect and dispose of metal fragments and product residues properly. See BMP S.2 in Chapter 5 for disposal alternatives.**

#### **Recommended BMPs**

The following BMPs are not required but can provide additional pollution protection:

- **Limit the amount of water used in quenching and rinsing. Recycle used water where possible.**
- **Cover the activity area to prevent rain from contacting the process, and to reduce the amount of runoff that has to be detained or treated.**

- Use a catch basin filter insert to capture stray metal particles. A catch basin filter may help remove dissolved metals. See Volume V of this Manual, Runoff Treatment BMPs for more information on catch basin filter inserts.
- Implement a program to track purchase and consumption of lubricants, solvents, and additives. Check with operating managers for an explanation if consumption increases. Recommend action if significant equipment leaks or spills are identified.
- Refer to the BMPs under sections A2 Transfer of Liquid Materials and A4 Storage and Stockpiling Activities, and utilize those BMPs which are applicable for materials storage and maintenance activities in your shop.

### **A3.4 WOOD TREATMENT AREAS**

**Description of Pollutant Sources:** Wood treatment includes both anti-staining and wood preserving using pressure processes or by dipping or spraying. Wood preservatives include creosote, creosote/coal tar, pentachlorophenol, copper naphthenate, arsenic trioxide, malathion, or inorganic arsenicals such as chromated copper arsenate, acid copper chromate, chromate zinc chloride, and fluor-chrome-arsenate-phenol. Anti-staining chemical additives include iodo-propenyl-butyl carbamate, dimethyl sulfoxide, didecyl dimethyl ammonium chloride, sodium azide, 8-quinolinol; copper (II) chelate, sodium ortho-phenylphenate, 2-(thiocyanomethylthio)-benzothiazole (TCMTB) and methylene bis- (thiocyanate), and zinc naphthenate.

Pollutant sources include drips of condensate or preservative after pressurized treatment; product washwater (in the treatment or storage areas), spills and leaks from process equipment and preservative tanks, fugitive emissions from vapors in the process, blowouts and emergency pressure releases, and kick-back from lumber (phenomenon where preservative leaks as it returns to normal pressure). Potential pollutants typically include the wood treating chemicals, BOD, suspended solids, oil and grease, benzene, toluene, ethylbenzene, phenol, chlorophenols, nitrophenols, heavy metals, and PAH depending on the chemical additive used.

**Pollutant Control Approach:** Cover and contain all wood treating areas and prevent all leaching of and stormwater contamination by wood treating chemicals. All wood treating facilities in Washington State are required to be covered under an Individual NPDES Permit.

#### **Required BMPs**

The individual NPDES Permit will require at a minimum the following BMPs:

- **Dedicate equipment that is used for treatment activities to prevent the tracking of treatment chemicals to other areas on the site.**
- **Eliminate non-process traffic on the drip pad. Scrub down non-dedicated lift trucks on the drip pad.**
- **Immediately remove and properly dispose of soils with visible surface contamination (green soil) to prevent the spread of chemicals to ground water and/or surface water via stormwater runoff.**
- **If any wood is observed to be contributing chemicals to the environment in the treated wood storage area, relocate it on a concrete chemical containment structure until the surface is clean and until it is drip free and surface dry.**
- **Cover and/or enclose, and contain with impervious surfaces, all wood treatment areas. Slope and drain areas around dip tanks, spray booths, retorts, and any other process equipment in a manner that allows return of treatment chemicals to the wood treatment process.**
- **Cover storage areas for freshly treated wood to prevent contact of treated wood products with stormwater. Segregate clean stormwater from process water. Ensure that all process water is conveyed to an approved treatment system.**

- Seal any holes or cracks in the asphalt areas that are subject to wood treatment chemical contamination.
- Elevate stored, treated wood products to prevent contact with stormwater run-on and runoff.
- Place dipped lumber over the dip tank, or on an inclined ramp for a minimum of 30 minutes to allow excess chemical to drip back to the dip tank.
- Place treated lumber either from dip tanks or retorts in a covered paved storage area for at least 24 hours before placement in outside storage. Use a longer storage period during cold weather unless the temporary storage building is heated. The wood shall be drip free and surface dry before it is moved outside.

#### **Recommended BMP**

- Consider using preservative chemicals that do not adversely impact receiving surface water and groundwater.

### A3.5 COMMERCIAL COMPOSTING

**Description of Pollutant Sources:** Commercial compost facilities, operating outside without cover, require large areas to decompose wastes and other feedstocks. These facilities should be designed to separate stormwater from leachate (i.e., industrial wastewater) to the greatest extent possible. When stormwater is allowed to contact any active composting areas, including waste receiving and processing areas, it becomes leachate. Pollutants in leachate include nutrients, biochemical oxygen demand (BOD), organics, coliform bacteria, acidic pH, color, and suspended solids. Stormwater at a compost facility consists of runoff from areas at the facility that are not associated with active processing and curing, such as product storage areas, vehicle maintenance areas, and access roads.

**NPDES Permit Requirements:** Discharge of leachate from a compost facility will require a State or NPDES permit from Ecology, depending on the disposal method chosen for managing leachate at the facility. (See Chapter 2 in “Compost Facility Resource Handbook, Guidance for Washington State”, November 1998, Publication # 97-502.) An additional alternative, zero discharge, is possible by containing all leachate from the facility (in tanks or ponds) or preventing production of leachate (by composting under a roof or in an enclosed building).

**Pollutant Control Approach:** Consider the leachate control specified in publication #97-502 or zero leachate discharge.

#### Required BMPs

- **Ensure that the compost feedstocks do not contain dangerous wastes, regulated under Chapter 173-303 WAC or hazardous products of a similar nature, or solid wastes that are not beneficial to the composting process. Employees must be trained to screen these materials in incoming wastes.**
- **Contact other federal and state agencies and the City of Tacoma regarding environmental or zoning authority for applicable permit and regulatory information. The Tacoma-Pierce County Health Department is responsible for issuing solid waste handling permits for commercial compost facilities.**
- **Apply for coverage under the General Permit to Discharge Stormwater Associated with Industrial Activities, if the facility discharges stormwater to surface water or a municipal stormwater system. If all stormwater from the facility infiltrates into the surrounding area, the General Permit is not required.**
- **Develop a plan of operations as outlined in the Compost Facility Resource Handbook, Publication #97-502.**
- **Store finished compost in a manner to prevent contamination of stormwater.**
- **Compost pads are required for all uncovered facilities in areas of the state with wet climates (per water quality regulations).**
- **Provide curbing for all compost pads to prevent stormwater run-on and leachate run-off.**

*Refer to “Compost Facility Resource Handbook, Guidance for Washington State,” November 1998, Publication # 97-502, for additional design criteria and information.*

- **Slope all compost pads sufficiently to direct leachate to the collection device.**
- **Provide one or more sumps or catch basins capable of collecting all leachate generated by the design storm and conveying it to the leachate holding structure for all compost pads.**
- **Convey all leachate from composting operations to a sanitary sewer, holding tank, or on-site treatment systems designed to treat the leachate and total suspended solids (TSS).**
- **Ponds used to collect, store, or treat leachate and other contaminated waters associated with the composting process must be lined to prevent ground water contamination. Apply “AKART” or All Known Available and Reasonable Methods of Prevention and Treatment to all pond liners, regardless of the construction materials.**

#### **Recommended BMPs**

- Clean up debris from yard areas regularly.
- Locate stored residues in areas designed to collect leachate.
- Limit storage times of residues to prevent degradation and generation of leachate.
- Consider using leachate as make-up water in early stages of the composting process. Since leachate can contain pathogenic bacteria, care should be taken to avoid contaminating finished product or nearly finished product with leachate.

### **A3.6 LANDSCAPING AND LAWN/VEGETATION MANAGEMENT**

**Description of Pollutant Sources:** Landscaping can include grading, soil transfer, vegetation removal, pesticide and fertilizer applications, and watering. Stormwater contaminants include toxic organic compounds, heavy metals, oils, total suspended solids, coliform bacteria, fertilizers, and pesticides.

Lawn and vegetation management can include control of objectionable weeds, insects, mold, bacteria and other pests with chemical pesticides and is conducted commercially at commercial, industrial, and residential sites. Examples include weed control on golf course lawns, access roads, and utility corridors and during landscaping; sap stain and insect control on lumber and logs; rooftop moss removal; killing nuisance rodents; fungicide application to patio decks, and residential lawn/plant care. Toxic pesticides such as pentachlorophenol, carbamates, and organometallics can be released to the environment by leaching and dripping from treated parts, container leaks, product misuse, and outside storage of pesticide contaminated materials and equipment. Poor management of the vegetation and poor application of pesticides or fertilizers can cause appreciable stormwater contamination.

**Pollutant Control Approach:** Control of fertilizer and pesticide applications, soil erosion, and site debris to prevent contamination of stormwater.

Develop and implement an Integrated Pest Management Plan (IPM) and use pesticides only as a last resort. Refer to Appendix IV-B Example of an Integrated Best Management Program for more information. If pesticides/herbicides are used they must be carefully applied in accordance with label instructions on U.S. Environmental Protection Agency (EPA) registered materials. Maintain appropriate vegetation, with proper fertilizer application where practicable, to control erosion and the discharge of stormwater pollutants. Where practicable grow plant species appropriate for the site, or adjust the soil properties of the subject site to grow desired plant species.

#### **Required BMPs for Landscaping**

- **Install engineered soil/landscape systems to improve the infiltration and regulation of stormwater in landscaped areas.**
- **Do not dispose of collected vegetation into waterways or storm drainage systems.**

#### **Recommended BMPs for Landscaping**

- Conduct mulch-mowing whenever practicable
- Dispose of grass clippings, leaves, sticks, or other collected vegetation, by composting, if feasible.
- Use mulch or other erosion control measures when soils are exposed for more than one week during the dry season or two days during the rainy season.
- If oil or other chemicals are handled, store and maintain appropriate oil and chemical spill cleanup materials in readily accessible locations. Ensure that employees are familiar with proper spill cleanup procedures.

- Till fertilizers into the soil rather than dumping or broadcasting onto the surface. Determine the proper fertilizer application for the types of soil and vegetation encountered.
- Till a topsoil mix or composted organic material into the soil to create a well-mixed transition layer that encourages deeper root systems and drought-resistant plants.
- Use manual and/or mechanical methods of vegetation removal rather than applying herbicides, where practical.

#### **Required BMPs for the Use of Pesticides**

- **Develop and implement an integrated pest management system (IPM) (See section on IPM at end of BMP) and use pesticides only as a last resort.**
- **Implement a pesticide-use plan and include at a minimum: a list of selected pesticides and their specific uses; brands, formulations, application methods and quantities to be used; equipment use and maintenance procedures; safety, storage, and disposal methods; and monitoring, record keeping, and public notice procedures. All procedures shall conform to the requirements of Chapter 17.21 RCW and Chapter 16-228 WAC (Appendix IV-D R.7).**
- **Choose the least toxic pesticide available that is capable of reducing the infestation to acceptable levels. The pesticide should readily degrade in the environment and/or have properties that strongly bind it to the soil. Any pest control used should be conducted at the life stage when the pest is most vulnerable. For example, if it is necessary to use a *Bacillus thuringiensis* application to control tent caterpillars, it must be applied before the caterpillars cocoon or it will be ineffective. Any method used should be site-specific and not used wholesale over a wide area.**
- **Apply the pesticide according to label directions. Under no conditions shall pesticides be applied in quantities that exceed manufacturer's instructions.**
- **Mix the pesticides and clean the application equipment in an area where accidental spills will not enter surface or ground waters, and will not contaminate the soil.**
- **Store pesticides in enclosed areas or in covered impervious containment. Ensure that pesticide contaminated stormwater or spills/leaks of pesticides are not discharged to storm drains. Do not hose down the paved areas to a storm drain or conveyance ditch. Store and maintain appropriate spill cleanup materials in a location known to all near the storage area.**
- **Clean up any spilled pesticides and ensure that the pesticide contaminated waste materials are kept in designated covered and contained areas.**
- **The pesticide application equipment must be capable of immediate shutoff in the event of an emergency.**



- **Do not spray pesticides within 100 feet of open waters including wetlands, ponds, and streams, sloughs and any drainage ditch or channel that leads to open water except when approved by Ecology or by the City of Tacoma. All sensitive areas including wells, creeks and wetlands must be flagged prior to spraying.**
- **As required by the City of Tacoma or by Ecology, complete public posting of the area to be sprayed prior to the application.**
- **Spray applications should only be conducted during weather conditions as specified in the label direction and applicable local and state regulations. Do not apply during rain or immediately before expected rain.**

### **Recommended BMPs for the use of Pesticides**

- Consider alternatives to the use of pesticides such as covering or harvesting weeds, substitute vegetative growth, and manual weed control/moss removal.
- Consider the use of soil amendments, such as compost, that are known to control some common diseases in plants, such as Pythium root rot, ashy stem blight, and parasitic nematodes. The following are three possible mechanisms for disease control by compost addition (USEPA Publication 530-F-9-044):
  1. Successful competition for nutrients by antibiotic production;
  2. Successful predation against pathogens by beneficial microorganism; and
  3. Activation of disease-resistant genes in plants by composts.

*Installing an amended soil/landscape system can preserve both the plant system and the soil system more effectively. This type of approach provides a soil/landscape system with adequate depth, permeability, and organic matter to sustain itself and continue working as an effective stormwater infiltration system and a sustainable nutrient cycle.*

- Once a pesticide is applied, its effectiveness should be evaluated for possible improvement. Records should be kept showing the applicability and inapplicability of the pesticides considered.
- An annual evaluation procedure should be developed including a review of the effectiveness of pesticide applications, impact on buffers and sensitive areas (including potable wells), public concerns, and recent toxicological information on pesticides used/proposed for use. If individual or public potable wells are located in the proximity of commercial pesticide applications contact the regional Ecology hydrogeologist to determine if additional pesticide application control measures are necessary.
- Rinsate from equipment cleaning and/or triple-rinsing of pesticide containers should be used as product or recycled into product.
- The application equipment used should be capable of immediate shutoff in the event of an emergency.

*For more information, contact the WSU Extension Home-Assist Program, (253) 445-4556, or Bio-Integral Resource Center (BIRC), P.O. Box 7414, Berkeley, CA.94707, or the Washington Department of Ecology to obtain "Hazardous Waste Pesticides" (Publication #89-41); and/or EPA to obtain a publication entitled "Suspended, Canceled and Restricted Pesticides" which lists all restricted pesticides and the specific uses that are allowed. Valuable information from these sources may also be available on the internet.*

## **Required BMPs for Vegetation Management**

- **Use at least an eight-inch "topsoil" layer with at least 8 percent organic matter to provide a sufficient vegetation-growing medium. Amending existing landscapes and turf systems by increasing the percent organic matter and depth of topsoil can substantially improve the permeability of the soil, the disease and drought resistance of the vegetation, and reduce fertilizer demand. This reduces the demand for fertilizers, herbicides, and pesticides. Organic matter is the least water-soluble form of nutrients that can be added to the soil. Composted organic matter generally releases only between 2 and 10 percent of its total nitrogen annually, and this release corresponds closely to the plant growth cycle. If natural plant debris and mulch are returned to the soil, this system can continue recycling nutrients indefinitely.**
- **Select the appropriate turfgrass mixture for your climate and soil type. Certain tall fescues and rye grasses resist insect attack because the symbiotic endophytic fungi found naturally in their tissues repel or kill common leaf and stem-eating lawn insects. They do not, however, repel root-feeding lawn pests such as Crane Fly larvae, and are toxic to ruminants such as cattle and sheep. The fungus causes no known adverse effects to the host plant or to humans. Endophytic grasses are commercially available and can be used in areas such as parks or golf courses where grazing does not occur. The local Cooperative Extension office can offer advice on which types of grass are best suited to the area and soil type.**
- **Use the following seeding and planting BMPs, or equivalent BMPs to obtain information on grass mixtures, temporary and permanent seeding procedures, maintenance of a recently planted area, and fertilizer application rates: Temporary Seeding, Mulching and Matting, Clear Plastic Covering, Permanent Seeding and Planting, and Sodding as described in Volume II, Construction Stormwater Pollution Prevention).**
- **Selection of desired plant species can be made by adjusting the soil properties of the subject site. For example, a constructed wetland can be designed to resist the invasion of reed canary grass by layering specific strata of organic matters (e.g., compost forest product residuals) and creating a mildly acidic pH and carbon-rich soil medium. Consult a soil restoration specialist for site-specific conditions.**
- **Aerate lawns regularly in areas of heavy use where the soil tends to become compacted. Aeration should be conducted while the grasses in the lawn are growing most vigorously. Remove layers of thatch greater than ¾-inch deep.**

- **Mowing is a stress-creating activity for turfgrass. When grass is mowed too short its productivity is decreased and there is less growth of roots and rhizomes. The turf becomes less tolerant of environmental stresses, more disease prone and more reliant on outside means such as pesticides, fertilizers and irrigation to remain healthy. Set the mowing height at the highest acceptable level and mow at times and intervals designed to minimize stress on the turf. Generally mowing only 1/3 of the grass blade height will prevent stressing the turf.**

***Irrigation:***

- **The depth from which a plant normally extracts water depends on the rooting depth of the plant. Appropriately irrigated lawn grasses normally root in the top 6 to 12 inches of soil; lawns irrigated on a daily basis often root only in the top 1 inch of soil. Improper irrigation can encourage pest problems, leach nutrients, and make a lawn completely dependent on artificial watering. The amount of water applied depends on the normal rooting depth of the turfgrass species used, the available water holding capacity of the soil, and the efficiency of the irrigation system. Consult with Tacoma Water, the Pierce Conservation District, or Cooperative Extension office to help determine optimum irrigation practices.**

***Fertilizer Management:***

- **Turfgrass is most responsive to nitrogen fertilization, followed by potassium and phosphorus. Fertilization needs vary by site depending on plant, soil and climatic conditions. Evaluation of soil nutrient levels through regular testing ensures the best possible efficiency and economy of fertilization. For details on soils testing, contact the Pierce Conservation District or Cooperative Extension Service.**
- **Fertilizers should be applied in amounts appropriate for the target vegetation and at the time of year that minimizes losses to surface and ground waters. Do not fertilize during a drought or when the soil is dry. Alternatively, do not apply fertilizers within three days prior to predicted rainfall. The longer the period between fertilizer application and either rainfall or irrigation, the less fertilizer runoff occurs.**

***Use slow release fertilizers such as methylene urea, IDBU, or resin coated fertilizers when appropriate, generally in the spring. Use of slow release fertilizers is especially important in areas with sandy or gravelly soils.***

- **Time the fertilizer application to periods of maximum plant uptake. Generally fall and spring applications are recommended, although WSU turf specialists recommend four fertilizer applications per year.**
- **Properly trained persons should apply all fertilizers. At commercial and industrial facilities fertilizers should not be applied to grass swales, filter strips, or buffer areas that drain to sensitive water bodies unless approved by the local jurisdiction.**

## ***Integrated Pest Management***

### **An IPM program might consist of the following steps:**

- Step 1: Correctly identify problem pests and understand their life cycle**
- Step 2: Establish tolerance thresholds for pests.**
- Step 3: Monitor to detect and prevent pest problems.**
- Step 4: Modify the maintenance program to promote healthy plants and discourage pests.**
- Step 5: Use cultural, physical, mechanical, or biological controls first if pests exceed the tolerance thresholds.**
- Step 6: Evaluate and record the effectiveness of the control and modify maintenance practices to support lawn or landscape recovery and prevent recurrence.**

**For an elaboration of these steps refer to Appendix IV-B, Example of an Integrated Best Management Program.**

### **A3.7 PAINTING, FINISHING AND COATING OF VEHICLES, BOATS, BUILDINGS AND EQUIPMENT**

**Description of Pollutant Sources:** Surface preparation and the application of paints, finishes and/or coatings to vehicles, boats, buildings, and/or equipment outdoors can be sources of pollutants. Potential pollutants include organic compounds, oils and greases, heavy metals, and suspended solids.

**Pollutant Control Approach:** Cover and contain painting and sanding operations and apply good housekeeping and preventive maintenance practices to prevent the contamination of stormwater with painting oversprays and grit from sanding.

#### **Required BMPs**

- **Train employees in the careful application of paints, finishes, and coatings to reduce misuse and over spray. Use ground or drop cloths underneath outdoor painting, scraping, sandblasting work, and properly clean and temporarily store collected debris daily.**
- **Do not conduct spraying, blasting, or sanding activities over open water or where wind may blow paint into water.**
- **Wipe up spills with rags and other absorbent materials immediately. Do not hose down the area to a storm drain or receiving water or conveyance ditch to receiving water.**
- **On marine dock areas sweep rather than hose down debris. Collect any hose water generated and convey to appropriate treatment and disposal.**
- **Use a storm drain cover, filter fabric, or similarly effective runoff control device if dust, grit, washwater, or other pollutants may escape the work area and enter a catch basin. The containment device(s) must be in place at the beginning of the workday. Collect contaminated runoff and solids and properly dispose of such wastes before removing the containment device(s) at the end of the workday.**
- **Use a ground cloth, pail, drum, drip pan, tarpaulin, or other protective device for activities such as paint mixing and tool cleaning outside or where spills can contaminate stormwater.**
- **Properly dispose of all wastes and prevent all uncontrolled releases to the air, ground or water.**
- **Clean brushes and tools covered with non-water-based paints, finishes, or other materials in a manner that allows collection of used solvents (e.g., paint thinner, turpentine, xylol, etc.) for recycling or proper disposal.**
- **Store toxic materials under cover (tarp, etc.) during precipitation events and when not in use to prevent contact with stormwater.**

**Enclose and/or contain all work while using a spray gun or conducting sand blasting and in compliance with applicable air pollution control, OSHA, and WISHA requirements. Do not conduct outside spraying, grit blasting, or sanding activities during windy conditions which render containment ineffective.**

#### **Recommended BMPs**

- Clean paintbrushes and tools covered with water-based paints in sinks connected to sanitary sewers or in portable containers that can be dumped into a sanitary sewer drain.
- Recycle paint, paint thinner, solvents, pressure washwater, and any other recyclable materials.
- Use efficient spray equipment such as electrostatic, air-atomized, high volume/low pressure, or gravity feed spray equipment.
- Purchase recycled paints, paint thinner, solvents, and other products if feasible.

### **A3.8 COMMERCIAL PRINTING OPERATIONS**

**Description of Pollutant Sources:** Materials used in the printing process include inorganic and organic acids, resins, solvents, polyester film, developers, alcohol, vinyl lacquer, dyes, acetates, and polymers. Waste products may include waste inks and ink sludge, resins, photographic chemicals, solvents, acid and alkaline solutions, chlorides, chromium, zinc, lead, spent formaldehyde, silver, plasticizers, and used lubricating oils. As the printing operations are conducted indoors, the only likely points of potential contact with stormwater are the outside temporary storage of waste materials and offloading of chemicals at external unloading bays. Pollutants can include TSS, pH, heavy metals, oil and grease, and COD.

**Pollutant Control Approach:** Ensure appropriate disposal and NPDES permitting of process wastes. Cover and contain stored raw and waste materials.

#### **Required BMPs**

- **Discharge process wastewaters to a sanitary sewer, or to an approved process wastewater treatment system, if approved by the City of Tacoma.**
- **Do not discharge process wastes or wastewaters into storm drains or surface water.**
- **Determine whether any of these wastes qualify for regulation as dangerous wastes and dispose of them accordingly.**
- **Store raw materials or waste materials that could contaminate stormwater in covered and contained areas.**

#### **Recommended BMPs**

- Train all employees in pollution prevention, spill response, and environmentally acceptable materials handling procedures.
- Store materials in proper, appropriately labeled containers. Identify and label all chemical substances.
- All stormwater management devices should be inspected regularly and maintained as necessary.
- Try to use press washes without listed solvents, and with the lowest VOC content possible. Don't evaporate ink cleanup trays to the outside atmosphere.
- Place cleanup sludges into a container with a tight lid and dispose of as hazardous waste. Do not dispose of cleanup sludges in the garbage or in containers of soiled towels.

For additional information on pollution prevention the following Washington Department of Ecology publications are recommended: [A Guide for Screen Printers](#), Publication #94-137R and [A Guide for Lithographic Printers](#), Publication #94-139R.

### **A3.9 MANUFACTURING OPERATIONS – OUTSIDE**

**Description of Pollutant Sources:** Manufacturing pollutant sources include outside process areas, stack emissions, and areas where manufacturing activity has taken place in the past and significant pollutant materials remain and are exposed to stormwater.

**Pollution Control Approach:** Cover and contain outside manufacturing and prevent stormwater run-on and contamination, where feasible.

#### **Required BMPs**

- **Sweep paved areas regularly, as needed, to prevent contamination of stormwater.**
- **Alter the activity by eliminating or minimizing the contamination of stormwater.**
- **Enclose the activity (see Figure 4.7). If possible, enclose the manufacturing activity in a building.**
- **Cover the activity and connect floor drains to a sanitary sewer, if approved by the City of Tacoma. Berm or slope the floor as needed to prevent drainage of pollutants to outside areas (see Figure 4.8).**
- **Isolate and segregate pollutants as feasible. Convey the segregated pollutants to a sanitary sewer, process treatment or a dead-end sump depending on available methods and applicable permit requirements.**



**SECTION A4**  
**STORAGE AND STOCKPILING ACTIVITIES**

#### **A4.1 BMPs FOR STORAGE OR TRANSFER (OUTSIDE) OF SOLID RAW MATERIALS, BY-PRODUCTS OR FINISHED PRODUCTS**

**Description of Pollutant Sources:** Solid raw materials, by-products, or products such as gravel, sand, salts, topsoil, compost, logs, sawdust, wood chips, lumber and other building materials, concrete, and metal products sometimes are typically stored outside in large piles, stacks, etc. at commercial or industrial establishments. Contact of outside bulk materials with stormwater can cause leachate, and erosion of the stored materials. Contaminants include TSS, BOD, organics, and dissolved salts (sodium, calcium, and magnesium chloride, etc).

**Pollutant Control Approach:** Provide impervious containment with berms, dikes, etc. and/or cover to prevent run-on and discharge of leachate pollutant(s) and TSS.

##### **Required BMPs**

- **Do not hose down the contained stockpile area to a storm drain or a conveyance to a storm drain or to receiving water.**
- **Choose one or more of the source control BMP options listed below for stockpiles greater than 5 cubic yards of erodible or water soluble materials such as soil, road deicing salts, compost, unwashed sand and gravel, sawdust, etc. Also included are outside storage areas for solid materials such as logs, bark, lumber, metal products, etc.**
- **Store in a building or paved and bermed covered area as shown in Figure 4.9, or;**
- **Place temporary plastic sheeting (polyethylene, polypropylene, hypalon, or equivalent) over the material as illustrated (see Figure 4.10), or;**
- **Pave the area and install a stormwater drainage system. Place curbs or berms along the perimeter of the area to prevent the run-on of uncontaminated stormwater and to collect and convey runoff to treatment. Slope the paved area in a manner that minimizes the contact between stormwater (e.g., pooling) and leachable materials in compost, logs, bark, wood chips, etc.**
- **For large stockpiles that cannot be covered, implement containment practices at the perimeter of the site and at any catch basins as needed to prevent erosion and discharge of the stockpiled material offsite or to a storm drain. Ensure that contaminated stormwater is not discharged directly to catch basins without being conveyed through a treatment BMP.**
- **Convey contaminated stormwater from the stockpile area to a wet pond, wet vault, settling basin, media filter, or other appropriate treatment system depending on the contamination.**

**Recommended BMPs:**

- Maintain drainage areas in and around storage of solid materials with a minimum slope of 1.5 percent to prevent pooling and minimize leachate formation. Areas should be sloped to drain stormwater to the perimeter where it can be collected, or to internal drainage “alleyways” where material is not stockpiled.
- Sweep paved storage areas regularly for collection and disposal of loose solid materials.
- If and when feasible, collect and recycle water-soluble materials (leachates) to the stockpile
- Stock cleanup materials, such as brooms, dustpans, and vacuum sweepers near the storage area.

## **A4.2 STORAGE AND TREATMENT OF CONTAMINATED SOILS**

**Description of Pollutant Sources:** This activity applies to businesses and agencies that store and treat soils contaminated with toxic organic compounds, petroleum products, or heavy metals. Such contamination typically comes to light when an environmental audit is done, or old underground tanks are removed. The soils are usually excavated and taken off-site for treatment via aeration and perhaps chemical stabilization. Stormwater runoff that comes in contact with contaminated soil can carry those contaminants along with loose dirt into receiving waters.

Pollutants of concern include toxic organic compounds, oils and greases and heavy metals.

**Pollutant Control Approach:** The Tacoma-Pierce County Health Department Waste Management Section at (253) 798-6047 regulates and permits businesses treating contaminated soil. In addition, a permit from the Puget Sound Clean Air Agency is required if the treatment method for removing soil contaminants involves forcing air through, or sucking air from, the soil. Contact these agencies for additional information regarding the appropriate pollutant control approach.

### **Required BMPs**

**The BMPs included here are intended as a supplement to other regulations. The following BMPs or equivalent measures are required of all businesses engaged in storage and treatment of contaminated soils:**

- **The storage area for contaminated soils must be enclosed indoors, covered, or contained by a curb, dike, or berm constructed around the material storage area. If the contaminated soils are covered, stormwater run-on protection must also be provided. BMP S.7 in Chapter 5 provides further details on containment and run-on prevention.**
- **Employees must be educated on methods to prevent contamination from leaving the site.**
- **Cleanup materials must be stocked near the storage area.**
- **Gutters, storm drains, catch basins, and other drainage system features on the site must be cleaned following the completion of site work, or at least once per year, whichever comes first. Sediments from such cleaning must be disposed of properly. See BMP S.9 and S.2 for details on catch basin cleaning and disposal options.**

### **Recommended BMPs**

The following BMPs are not required but can provide additional pollution protection:

- **If feasible, the storage area should be swept weekly for collection of stray soil, which can be added back to the piles, or properly disposed. See BMP S.2 in Chapter 5 for information on disposal options.**

- Implement one of the following treatment BMPs in conjunction with a runoff containment plan:
  - Vegetated biofilter.
  - Catch basin insert for the targeted pollutants or wet vault.
  - Or equivalent BMP, see Volume V.

The use of any treatment BMP must not result in the violation of groundwater, surface water, or drinking water quality standards.

### **A4.3 TEMPORARY STORAGE OR PROCESSING OF FRUITS OR VEGETABLES**

**Description of Pollutant Sources:** This activity applies to businesses that temporarily store fruits and vegetables outdoors prior to processing or sale, or that crush, cut, or shred fruits or vegetables for wines, frozen juices, and other food and beverage products. Nutrients and soil washing off of fruit can have a detrimental effect on receiving waters.

Pollutants of concern include nutrients, suspended solids, biochemical oxygen demand (BOD) and color.

**Pollutant Control Approach:** Store and process fruits and vegetables indoors or under cover whenever possible. Educate employees about proper procedures. Eliminate illicit connections to the storm drainage system. Cover and contain operations and apply good housekeeping and preventive maintenance practices to prevent the contamination of stormwater.

#### **Required BMPs**

The following BMPs or equivalent measures are required of all businesses engaged in *storage* of fruits or vegetables:

- **Employees must be educated on benefits of keeping a clean storage area.**
- **Eliminate illicit connections to the storm drainage system. See BMP S.1 in Chapter 5 for details on detecting and eliminating these connections.**
- **No untreated water used to clean produce can enter the storm drainage system. Minimize the use of water when cleaning produce to avoid excess runoff.**
- **Cleanup materials, such as brooms and dustpans, must be kept near the storage area.**
- **Gutters, storm drains and catch basins on the property must be cleaned as needed. See BMP S.9 in Chapter 5 for details on catch basin cleaning requirements.**

The following BMPs or equivalent measures are required of all businesses that *process* fruits or vegetables:

- **Eliminate illicit connections to the storm drainage system. See BMP S.1 in Chapter 5 for details on detecting and eliminating these connections.**
- **Employees must be educated on benefits of keeping a clean processing area.**
- **Cleanup materials, such as brooms, dustpans and shovels, must be kept near the storage area.**
- **The processing area must be swept or shoveled daily to collect dirt, fruit and vegetable fragments for proper disposal.**

- **The processing area must be enclosed in a building or shed, or covered with provisions for stormwater run-on prevention. See BMP S.4, S.5, and S.7 in Chapter 5 for more on covering and run-on prevention.**

**OR**

**The processing area must be paved and sloped to a sanitary sewer drain, holding tank, or process treatment system collection drain, and stormwater run-on prevention must be provided for the processing area. Call the Tacoma Sanitary Source Control Unit at 591-5588 for information on discharging to the sanitary sewer. See BMP S.6 and S.3 in Chapter 5 for details on paving and drainage.**

### **Recommended BMPs**

The following BMPs are not required but can provide additional pollution protection:

- Cover storage areas for fruits and vegetables. See BMP S.4 and S.5 in Chapter 5 for more details on coverings.
- A containment curb, dike, or berm can be used to prevent offsite runoff from storage or processing areas and also to prevent stormwater run-on. See BMP S.7 in Chapter 5 for more information. Note that run-on prevention is required for processing areas, but not for storage areas.
- The storage area should be swept or shoveled daily to collect dirt and fruit and vegetable fragments for proper disposal. Keep hosing to a minimum.
- Use one or a combination of the following treatment BMPs:
  - Wet pond or wet vault to treat storage area runoff.
  - Vegetated biofilter to treat storage area runoff.
  - Catch basin, with appropriate insert for the targeted pollutants, to treat storage area runoff. See S.9 in Chapter 5 for information on catch basin cleaning.
  - Or equivalent BMP, see Volume V.

#### **A4.4 STORAGE OF SOLID WASTES AND FOOD WASTES**

**Description of Pollutant Sources:** This activity applies to businesses and public agencies that store solid wastes and food wastes outdoors. This includes ordinary garbage. If improperly stored in our climate, these wastes can contribute a variety of different pollutants to stormwater. Requirements for handling and storing solid waste may require a permit from the Tacoma-Pierce County Health Department. For more information, call the Waste Management Section at 253-798-6047.

NOTE: Dangerous solid wastes must be stored and handled under special guidelines. Businesses and agencies that store dangerous wastes must follow specific regulations outlined by the Department of Ecology, and in some cases, the Tacoma-Pierce County Health Department (TPCHD). Ecology regulations are outlined in Chapter 6. Please contact the Department of Ecology at 360-407-6300 and the TPCHD at 253-798-6047 for the specific requirements and permitting information.

Pollutants of concern include toxic organic compounds, oils and greases, heavy metals, nutrients, suspended solids, chemical oxygen demand (COD) and biochemical oxygen demand (BOD).

**Pollutant Control Approach:** Store wastes in suitable containers with leak proof lids. Sweep or shovel loose solids. Educate employees about the need to check for and replace leaking containers.

#### **Required BMPs**

**The following BMPs are required of all businesses and public agencies engaged in storage of non-dangerous solid wastes or food wastes:**

- **All solid and food wastes must be stored in suitable containers. Piling of wastes without any cover is not acceptable.**
- **Storage containers must be checked for leaks and replaced if they are leaking, corroded, or otherwise deteriorating.**
- **Storage containers must have leak-proof lids, or else be covered by some other means. Lids must be kept closed at all times. This is especially important for dumpsters, as birds can pick out garbage and drop it, promoting rodent, health and stormwater problems.**

**OR**

**If lids cannot be provided for the waste containers, or they cannot otherwise be covered, there is another option: a designated waste storage area must be provided with a containment berm, dike or curb, and the designated area must drain to a sanitary sewer or holding tank for further treatment. See BMP S.7 and S.3 in Chapter 5 for more information.**

- **Employees must be trained to frequently check storage containers for leaks and to ensure that the lids are on tightly.**



- **The waste storage area must be swept or otherwise cleaned frequently to collect all loose solids for proper disposal in a storage container. Do not hose the area to collect or clean solids.**
- **If you clean your containers, all rinse water from cleaning must be disposed of in a sanitary sewer or septic system.**
- **Clean out catch basins on your property that receive drainage from your waste storage area. See BMP S.9 in Chapter 5 for details on catch basin cleaning.**

### **Recommended BMPs**

The following BMPs are not required, but can provide additional pollution protection:

- If the amount of waste accumulated appears to frequently exceed the capacity of the storage container, then another storage container should be obtained and utilized.
- Store containers such that wind will not be able to knock them over.
- Designate a storage area, pave the area, and slope the drainage to a holding tank or sanitary sewer drain. If a holding tank is used, the contents must be pumped out before the tank is full, and properly disposed. See BMP S.2 in Chapter 5 for more information on disposal options.
- Compost appropriate wastes. Contact Tacoma Solid Waste Utility Recycling and Composting at 253-565-5955 for more information on composting.
- Recycle your solid wastes. The Industrial Materials Exchange (IMEX) program facilitates the transfer of excess materials and wastes to those who can use them. IMEX can be reached at 206-296-4899, or use the IMEX computer bulletin board modem access number at 1-800-858-6625.

#### **A4.5 RECYCLERS AND SCRAP YARDS**

**Description of Pollutant Sources:** Includes businesses that reclaim various materials for resale or for scrap, such as vehicles and vehicle/ equipment parts, construction materials, metals, beverage containers, and papers.

Potential sources of pollutants include paper, plastic, metal scrap debris, engines, transmissions, radiators, batteries, and other materials that contain fluids or are contaminated with fluids. Other pollutant sources include leachate from metal components, contaminated soil, and the erosion of soil. Activities that can generate pollutants include the transfer, dismantling, and crushing of vehicles and scrap metal; the transfer and removal of fluids; maintenance and cleaning of vehicles, parts, and equipment; and storage of fluids, parts for resale, solid wastes, scrap parts, and materials, equipment and vehicles that contain fluids; generally in uncovered areas.

Potential pollutants typically found at vehicle recycle and scrap yards include oil and grease, ethylene and propylene glycol, total suspended solids, BOD, heavy metals, and acidic pH.

#### **Required BMPs**

**For facilities subject to Ecology's Industrial Stormwater General Permit refer to BMP Guidance Document #94-146, "Best Management Practices to Prevent Stormwater Pollution at Vehicle Recycler Facilities," Washington Department of Ecology, September 1994 for selection of BMPs. The BMPs in that guidance document can also be applied to scrap material recycling facilities depending on the pollutant sources existing at those facilities and to non-permitted facilities.**

#### **A4.6 TREATMENT, STORAGE, OR DISPOSAL OF DANGEROUS WASTES**

This activity applies to businesses and public agencies that are permitted by the Washington State Department of Ecology to treat, store, or dispose of dangerous wastes. DOE regulates these facilities with specific requirements, which include the need for a National Pollutant Discharge Elimination System (NPDES) permit. Detailed BMPs are not included in this manual since site requirements for these facilities are well beyond the level of typical BMP applications. See Chapter 6 for reference information.

The Tacoma-Pierce County Health Department also administers some aspects of dangerous waste treatment, storage and disposal. Call 253-798-6047 for more information.

## **A4.7 STORAGE OF LIQUID, FOOD WASTE OR DANGEROUS WASTE CONTAINERS**

**Description of Pollutant Sources:** Steel and plastic drums with volumetric capacities of 55 gallons or less are typically used at industrial facilities for container storage of liquids and powders. The BMPs specified below apply to container(s) located outside a building used for temporary storage of accumulated food wastes, vegetable or animal grease, used oil, liquid feedstock or cleaning chemical, or Dangerous Wastes (liquid or solid) unless the business is permitted by Ecology to store the wastes. Leaks and spills of pollutant materials during handling and storage are the primary sources of pollutants. Oil and grease, acid/alkali pH, BOD, and COD are potential pollutant constituents.

**Pollutant Control Approach:** Store containers in impervious containment under a roof or other appropriate cover, or in a building. For roll-containers (for example, dumpsters) that are picked up directly by the collection truck, a filet can be placed on both sides of the curb to facilitate moving the dumpster. If a storage area is to be used on-site for less than 30 days, a portable temporary secondary system like that shown in Figure 4.11 can be used in lieu of a permanent system as described above.

### **Required BMPs**

- **Place tight-fitting lids on all containers.**
- **Place drip pans beneath all mounted container taps and at all potential drip and spill locations during filling and unloading of containers.**
- **Inspect container storage areas regularly for corrosion, structural failure, spills, leaks, overfills, and failure of piping systems. Check containers daily for leaks/spills. Replace containers, and replace and tighten bungs in drums as needed.**
- **Businesses accumulating Dangerous Wastes that do not contain free liquids need only to store these wastes in a sloped designated area with the containers elevated or otherwise protected from stormwater run-on.**
- **Drums stored in an area where unauthorized persons may gain access must be secured in a manner that prevents accidental spillage, pilferage, or any unauthorized use (see Figure 4.12).**
- **If the material is a Dangerous Waste, the business owner must comply with any additional Ecology requirements as specified in Chapter 6, Section 6.2, R.2.**
- **Storage of reactive, ignitable, or flammable liquids must comply with the Uniform Fire Code.**
- **Cover dumpsters, or keep them under cover such as a lean-to, to prevent the entry of stormwater. Replace or repair leaking garbage dumpsters.**
- **Drain dumpsters and/or dumpster pads to sanitary sewer. Keep dumpster lids closed. Install waterproof liners.**

- **Keep containers with Dangerous Waste, food waste, or other potential pollutant liquids inside a building unless this is impracticable due to site constraints or Uniform Fire Code requirements.**
- **Store containers in a designated area, which is covered, bermed or diked, paved and impervious in order to contain leaks and spills (see Figure 4.13). The secondary containment shall be sloped to drain into a dead-end sump for the collection of leaks and small spills.**
- **For liquid wastes, surround the containers with a dike as illustrated in Figure 4.13. The dike must be of sufficient height to provide a volume of either 10 percent of the total enclosed container volume or 110 percent of the volume contained in the largest container, whichever is greater, or, if a single container, 110 percent of the volume of that container.**
- **Where material is temporarily stored in drums, a containment system can be used as illustrated, in lieu of the above system (see Figure 4.11).**
- **Place containers mounted for direct removal of a liquid chemical for use by employees inside a containment area as described above. Use a drip pan during liquid transfer (see Figure 4.14).**
- **For contaminated stormwater in the containment area, connect the sump outlet to a sanitary sewer, if approved by the City of Tacoma, or to appropriate treatment such as an API or CP oil/water separator, catch basin filter or other appropriate system (see Volume V). Equip the sump outlet with a normally closed valve to prevent the release of spilled or leaked liquids, especially flammables (compliance with Fire Codes), and dangerous liquids. This valve may be opened only for the conveyance of contaminated stormwater to treatment.**
- **Another option for discharge of contaminated stormwater is to pump it from a dead-end sump or catchment to a tank truck or other appropriate vehicle for off-site treatment and/or disposal.**

## A4.8 STORAGE OF LIQUIDS IN PERMANENT ABOVE-GROUND TANKS

**Description of Pollutant Sources:** Above-ground tanks containing liquids (excluding uncontaminated water) may be equipped with a valved drain, vent, pump, and bottom hose connection. They may be heated with steam heat exchangers equipped with steam traps. Leaks and spills can occur at connections and during liquid transfer. Oil and grease, organics, acids, alkalis, and heavy metals in tank water and condensate drainage can also cause stormwater contamination at storage tanks.

**Pollutant Control Approach:** Install secondary containment or a double-walled tank. Slope the containment area to a drain with a sump. Stormwater collected in the containment area may need to be discharged to treatment such as an API or CP oil/water separator, or equivalent BMP. Add safeguards against accidental releases including protective guards around tanks to protect against vehicle or forklift damage, and tagging valves to reduce human error. *Tank water and condensate discharges are process wastewater that may need an NPDES Permit.*

### Required BMPs

- **Inspect the tank containment areas regularly to identify problem components such as fittings, pipe connections, and valves, for leaks/spills, cracks, corrosion, etc.**
- **Place adequately sized drip pans beneath all mounted taps and drip/spill locations during filling/unloading of tanks. Valved drain tubing may be needed in mounted drip pans.**
- **Sweep and clean the tank storage area regularly, if paved.**
- **Replace or repair tanks that are leaking, corroded, or otherwise deteriorating.**
- **All installations shall comply with the Uniform Fire Code and the National Electric Code.**
- **Locate permanent tanks in impervious (Portland cement concrete or equivalent) secondary containment surrounded by dikes as illustrated in Figure 4.15, or UL Approved double-walled. The dike must be of sufficient height to provide a containment volume of either 10 percent of the total enclosed tank volume or 110 percent of the volume contained in the largest tank, whichever is greater, or, if a single tank, 110 percent of the volume of that tank.**
- **Slope the secondary containment to drain to a dead-end sump (optional), or equivalent, for the collection of small spills.**
- **Include a tank overfill protection system to minimize the risk of spillage during loading.**
- **If the tank containment area is uncovered, equip the outlet from the spill-containment sump with a shutoff valve, which is normally closed and may be opened, manually or automatically, only to convey contaminated stormwater to approved treatment or disposal, or to convey uncontaminated stormwater to a storm drain. Evidence of contamination can include the presence of visible sheen, color, or turbidity in the**

**runoff, or existing or historical operational problems at the facility. Simple pH measurements with litmus or pH paper can be used for areas subject to acid or alkaline contamination.**

- **At petroleum tank farms, convey stormwater contaminated with floating oil or debris in the contained area through an API or CP-type oil/water separator (Volume V, Treatment BMPs), or other approved treatment prior to discharge to storm drain or surface water.**

#### **A4.9 PARKING AND STORAGE FOR VEHICLES AND EQUIPMENT**

**Description of Pollutant Sources:** Public and commercial parking lots such as retail store, fleet vehicle (including rent-a-car lots and car dealerships), equipment sale and rental parking lots, and parking lot driveways, can be sources of toxic hydrocarbons and other organic compounds, oils and greases, metals, and suspended solids caused by the parked vehicles.

##### **Required BMPs**

- **If washing of a parking lot is conducted, discharge the washwater to a sanitary sewer, or other approved wastewater treatment system, if allowed by the City of Tacoma, or collect it for off-site disposal.**
- **Do not hose down the area to a storm drain or to a receiving water. Sweep parking lots, storage areas, and driveways, regularly to collect dirt, waste, and debris.**
- **An oil removal system such as an API or CP oil and water separator, catch basin filter, or equivalent BMP (see Volume V), approved by the City of Tacoma, is applicable for parking lots meeting the threshold vehicle traffic intensity level of a high-use site. For more information on high use sites, refer to Volume I, Section 4.2, Step V, Step 2.**



**A4.10 LOADING AND UNLOADING AREAS FOR SOLID MATERIAL**

**(Please refer to A2.1, Loading and Unloading Areas for Liquid and Solid Material.)**

**SECTION A5**  
**CONSTRUCTION AND DEMOLITION ACTIVITIES**

## **A5.1 CLEARING, GRADING AND PREPARATION OF CONSTRUCTION SITES**

This activity applies to businesses and municipal agencies that develop lands for construction. It also applies to residences that undertake large yard clearing and grading projects. Stormwater runoff from bare ground can be loaded with dirt and other pollutants. This material can clog ditches and stream channels, thus reducing carrying capacity and increasing flooding, as well as smothering spawning beds for fish. Simply controlling runoff and not allowing it to leave the site will prevent these harmful effects. Clearing, grading and preparation activities are covered in detail in Volume II of this Manual, Construction Stormwater Pollution Prevention. Grading activities are also regulated in the City of Tacoma by the Grading and Excavation Code, Section 2.02.330 of the official code of the City of Tacoma.

An NPDES permit is needed from the Washington state Department of Ecology (Ecology) where five (5) or more acres of land is disturbed. Beginning in 2003, coverage under Ecology's General Permit will be required for construction sites that result in the disturbance of one acre or more of land. Compliance with the Construction Stormwater Pollution Prevention requirements in Ecology's manual is required, as applicable.

## **A5.2 DEMOLITION OF BUILDINGS**

**Description of Pollutant Sources:** This activity applies to removal of existing buildings by controlled explosions, wrecking balls, or manual methods, and subsequent clearing of the rubble. The loose debris can contaminate stormwater.

Pollutants of concern include toxic organic compounds, heavy metals and suspended solids.

**Pollutant Control Approach:** Regularly clean up debris that can contaminate stormwater. Protect the storm drainage system from dirty runoff and loose particles. Sweep paved surfaces daily.

### **Required BMPs**

**The following BMPs or equivalent measures are required of all businesses and public agencies engaged in building demolition:**

- **1. Storm drain covers or a similarly effective containment device must be placed on all nearby drains to prevent dirty runoff and loose particles from entering the storm drainage system. Covers shall be placed at the beginning of the work day and the accumulated materials collected and disposed before removing the covers at the end of the work day. If storm drains are not present, dikes, berms or other methods must be used to protect overland discharge paths from runoff. See BMP S.2 and S.7 in Chapter 5 for more information on runoff control and disposal options.**
- **2. Street gutters, sidewalks, driveways, and other paved surfaces in the immediate area of the demolition must be swept at the end of each work day to collect and properly dispose of loose debris and garbage.**

### **Recommended BMPs**

The following BMPs are not required but can provide additional pollution protection:

- Water should be sprayed throughout the site to help control wind blowing of fine materials such as soil, concrete dust, and paint chips. The amount of water must be controlled so that runoff from the site does not occur, yet dust control is achieved. Oils must never be used for dust control.
- If possible, a wall should be constructed to prevent stray building materials and dust from escaping the area during demolition.
- Install catch basin filter inserts to treat site runoff. Additional information about catch basin filter inserts can be found in Volume V of this Manual, Runoff Treatment BMPs.
- Schedule demolition to take place at a dry time of the year.

### **A5.3 BUILDING REPAIR, REMODELING AND CONSTRUCTION**

**Description of Pollutant Sources:** This activity refers to activities associated with construction of buildings and other structures, remodeling of existing buildings and houses, and general exterior building repair work. Painting of buildings is covered under **A3.10 Painting, Finishing and Coating of Vehicles, Boats, Buildings and Equipment**. Concrete pouring is covered under **A3.2 Concrete Pouring and Asphalt Application at Temporary Sites**.

Pollutants of concern include toxic hydrocarbons, toxic organics, suspended solids, heavy metals, pH, oils and greases.

**Pollutant Control Approach:** Employees must be educated about the need to control site activities. Control leaks, spills and loose material. Utilize good housekeeping practices.

#### **Required BMPs**

The following BMPs or equivalent measures are required of all businesses engaged in building repair, remodeling and construction:

- **Employees must be educated about the need to control site activities to prevent stormwater pollution, and also trained in spill cleanup procedures.**
- **Spill cleanup materials, appropriate to the chemicals being used on site, must be available at the work site at all times.**
- **The work site must be cleaned up at the end of each work day, with materials such as solvents put away indoors or covered and secured so that vandals will not have access to them.**
- **The area must be swept daily to collect loose litter, paint chips, grit, and dirt.**
- **Absolutely no substance can be dumped on pavement, on the ground, in or toward storm drains, regardless of its content, unless it is water only.**
- **Ground or drop cloths must be used underneath scraping and sandblasting work. Groundcloths, buckets, or tubs must also be used anywhere that work materials are laid down.**
- **Tools covered with non-water-based finishes, or other materials must be cleaned in a manner that enables collection of used solvents for recycling or proper disposal. See BMP S.2 in Chapter 5 for disposal options.**
- **Storm drain covers or similarly effective devices must be used if dust, grit, washwater, or other pollutants may escape the work area. This is particularly necessary on rainy days. The cover or containment device shall be placed over the storm drain at the beginning of the work day, and accumulated dirty runoff and solids must be collected and disposed of before removing the cover at the end of the day.**

## **Recommended BMPs**

The following BMPs are not required but can provide additional pollution protection:

- Recycle materials whenever possible.
- Light spraying of water on the work site can control some of the dust and grit that can blow away. Oils must never be used for dust control. Never spray to the point of runoff from the site.
- Activities such as tool cleaning should occur over a ground cloth or within a containment device such as a tub.
- Catch basin filter inserts should be considered if work will be ongoing for an extended period of time or if significant amounts of hydrocarbons, oils and greases, heavy metals, or suspended solids are expected in site runoff. Additional information about catch basin filter inserts can be found in Volume V of this Manual, Runoff Treatment BMPs.

**SECTION A6**

**DUST CONTROL AND SOIL AND SEDIMENT CONTROL**

## **A6.1 BMPs FOR DUST CONTROL AT DISTURBED LAND AREAS AND UNPAVED ROADWAYS AND PARKING LOTS**

**Description of Pollutant Sources:** Dust can cause air and water pollution problems particularly at demolition sites, disturbed land areas, and unpaved roadways and parking lots.

**Pollutant Control Approach:** Minimize dust generation and apply environmentally friendly and government approved dust suppressant chemicals, if necessary.

### **Required BMPs**

- **Sprinkle or wet down soil or dust with water as long as it does not result in a wastewater discharge.**
- **Use only local and/or state government approved dust suppressant chemicals such as those listed in Ecology Publication #96-433, "Techniques for Dust Prevention and Suppression."**
- **Avoid excessive and repeated applications of dust suppressant chemicals. Time the application of dust suppressants to avoid or minimize their wash-off by rainfall or human activity such as irrigation.**
- **Apply stormwater containment to prevent the conveyance of stormwater TSS into storm drains or receiving waters.**
- **The use of motor oil or other oils for dust control is prohibited. Care should be taken when using lignin derivatives and other high BOD chemicals in excavations or areas easily accessible to surface water or ground water.**
- **Consult with the Ecology Regional Office in your area on discharge permit requirements if the dust suppression process results in a wastewater discharge to the ground, ground water, storm drain, or surface water.**

### **Recommended BMPs for Roadways and Other Trafficked Areas:**

- Consider limiting use of off-road recreational vehicles on dust generating land.
- Consider paving unpaved permanent roads and other trafficked areas at municipal, commercial, and industrial areas.
- Consider paving or stabilizing shoulders of paved roads with gravel, vegetation, or local government approved chemicals.
- Encourage use of alternate paved routes, if available.
- Vacuum or wet sweep fine dirt and skid control materials from paved roads soon after winter weather ends or when needed.
- Consider using traction sand that is pre-washed to reduce dust emissions.



**Recommended BMPs for Dust Generating Areas:**

- Prepare a dust control plan. Helpful references include: Control of Open Fugitive Dust Sources (EPA-450/3-88-088), and Fugitive Dust Background Document and Technical Information Document for Best Available Control Measures (EPA-450/2-92-004)
- Limit exposure of soil (dust source) as much as feasible.
- Stabilize dust-generating soil by growing and maintaining vegetation, mulching, topsoiling, and/or applying stone, sand, or gravel.
- Apply windbreaks in the soil such as trees, board fences, tarp curtains, bales of hay, etc.
- Cover dust-generating piles with wind-impervious fabric, or equivalent material.

## **A6.2 DUST CONTROL AT MANUFACTURING SITES**

**Description of Pollutant Sources:** Industrial material handling activities can generate considerable amounts of dust that is typically removed using exhaust systems. This can generate air emissions that can contaminate stormwater. Dusts can be generated at cement and concrete products mixing, and wherever powdered materials are handled. Particulate materials that are of concern to air pollution control agencies include grain dust, sawdust, coal, gravel, crushed rock, cement, and boiler fly ash. The objective of this BMP is to reduce the stormwater pollutants caused by dust generation and control.

**Pollutant Control Approach:** Prevent dust generation and emissions where feasible, regularly clean-up dust that can contaminate stormwater, and convey dust contaminated stormwater to proper treatment.

### **Required BMPs**

- **Clean, as needed, powder material handling equipment and vehicles that can be sources of stormwater pollutants, to remove accumulated dust and residue.**
- **Regularly sweep dust accumulation areas that can contaminate stormwater. Sweeping should be conducted using vacuum filter equipment to minimize dust generation and to ensure optimal dust removal.**

### **Recommended BMPs**

- In manufacturing operations, train employees to carefully handle powders to prevent generation of dust.
- Use dust filtration/collection systems such as bag house filters, cyclone separators, etc. to control vented dust emissions that could contaminate stormwater. Control of zinc dusts in rubber production is one example.
- Use water spray to flush dust accumulations to sanitary sewers where allowed by the City of Tacoma or to other appropriate treatment system.
- Use approved dust suppressants such as those listed in Ecology Publication "Techniques for Dust Prevention and Suppression," #96-433. (Ecology, 1996). Application of some products may not be appropriate in close proximity to receiving waters or conveyances close to receiving waters. For more information check with the Ecology Regional Office or the local jurisdiction.
- For removal of TSS in stormwater use sedimentation basins, wet ponds, wet vaults, catch basin filters, vegetated filter strips, or equivalent sediment removal BMPs. Refer to Volume V Runoff Treatment BMPs for more information about these BMPs.

### **A6.3 SOIL EROSION AND SEDIMENT CONTROL AT INDUSTRIAL SITES**

**Description of Pollutant Sources:** Industrial activities on soil areas; exposed and disturbed soils; steep grading; etc. can be sources of sediments that can contaminate stormwater runoff.

**Pollutant Control Approach:** Limit the exposure of erodible soil, stabilize or cover erodible soil where necessary to prevent erosion, and/or provide treatment for stormwater contaminated with TSS caused by eroded soil.

#### **Required BMPs**

- **Vegetative cover such as grass, trees, shrubs, on erodible soil areas; or,**
- **Covering with mats such as clear plastic, jute, synthetic fiber; and/or,**
- **Preservation of natural vegetation including grass, trees, shrubs, and vines, vegetated swale, dike, silt fence, check dam, gravel filter berm, sedimentation basin, and proper grading. (For design information refer to Volume II, “Standards and Specifications for BMPs”).**

**SECTION A7  
OTHER ACTIVITIES**

## **A7.1 COMMERCIAL ANIMAL HANDLING AREAS**

**Description of Pollutant Sources:** Animals at racetracks, kennels, fenced pens, veterinarians, and businesses that provide boarding services for horses, dogs, cats, etc., can generate pollutants from the following activities: manure deposits, animal washing, grazing and any other animal handling activity that could contaminate stormwater. Pollutants can include coliform bacteria, nutrients, and total suspended solids.

**Pollutant Control Approach:** To prevent, to the maximum extent practicable, the discharge of contaminated stormwater from animal handling and keeping areas.

### **Required BMPs**

- **Regularly sweep and clean animal keeping areas to collect and properly dispose of droppings, uneaten food, and other potential stormwater contaminants.**
- **Do not hose down to storm drains or to receiving water those areas that contain potential stormwater contaminants.**
- **Do not allow any washwaters to be discharged to storm drains or to receiving water without proper treatment.**
- **If animals are kept in unpaved and uncovered areas, the ground must either have vegetative cover or some other type of ground cover such as mulch.**
- **If animals are not leashed or in cages, the area where animals are kept must be surrounded by a fence or other means that prevents animals from moving away from the controlled area where BMPs are used.**

## **A7.2 LOG SORTING AND HANDLING**

**Description of Pollutant Sources:** Log yards are paved or unpaved areas where logs are transferred, sorted, debarked, cut, and stored to prepare them for shipment or for the production of dimensional lumber, plywood, chips, poles, or other products. Log yards are generally maintained at sawmills, shipping ports, and pulp mills. Typical pollutants include oil and grease, BOD, settleable solids, total suspended solids (including soil), high and low pH, heavy metals, pesticides, wood-based debris, and leachate.

The following are pollutant sources:

1. Log storage, rollout, sorting, scaling, and cutting areas
2. Log and liquid loading areas
3. Log sprinkling
4. Debarking, bark bin and conveyor areas
5. Bark, ash, sawdust and wood debris piles, and other solid wastes
6. Metal salvage areas
7. Truck, rail, ship, stacker, and loader access areas
8. Log trucks, stackers, loaders, forklifts, and other heavy equipment
9. Maintenance shops and parking areas
10. Cleaning areas for vehicles, parts, and equipment
11. Storage and handling areas for hydraulic oils, lubricants, fuels, paints, liquid wastes, and other liquid materials
12. Pesticide usage for log preservation and surface protection
13. Application of herbicides for weed control
14. Contaminated soil resulting from leaks or spills of fluids

### **Ecology's Baseline General Permit Requirements:**

Industries with log yards are required to obtain coverage under the baseline general permit for discharges of stormwater associated with industrial activities to surface water. The permit requires preparation and on-site retention of Stormwater Pollution Prevention Plans (SWPPP). The SWPPP must identify operational, source control, erosion and sediment control and, if necessary, treatment BMPs. Required and recommended operational, source control, and treatment BMPs are presented in detail in Ecology's Guidance Document: Best Management Practices to Prevent Stormwater Pollution at Log Yards, Publication # 95-53, May 1995. It is recommended that all log yard facilities obtain a copy of this document. Ecology is revising this manual. The revised BMP Manual for Log Yards should be available January 31, 2003.

### **A7.3 BOAT BUILDING, MOORING, MAINTENANCE AND REPAIR**

**Description of Pollutant Sources:** Sources of pollutants at boat and shipbuilding, repair, and maintenance at boatyards, shipyards, ports, and marinas include pressure washing, surface preparation, paint removal, sanding, painting, engine maintenance and repairs, and material handling and storage, if conducted outdoors. Potential pollutants include spent abrasive grits, solvents, oils, ethylene glycol, washwater, paint over-spray, cleaners/ detergents, anti-corrosive compounds, paint chips, scrap metal, welding rods, resins, glass fibers, dust, and miscellaneous trash. Pollutant constituents include TSS, oil and grease, organics, copper, lead, tin, and zinc.

**Pollutant Control Approach:** Apply good housekeeping, preventive maintenance and cover and contain BMPs in and around work areas.

#### **Required BMPs**

The following BMPs or equivalent measures are required of all businesses, public agencies and private boat owners engaged in boat building, mooring, maintenance and repair that are not covered by the NPDES permit for boatyards:

- **Maintenance and repair activities that can be moved on-shore must be moved accordingly. This action reduces some of the potential for direct pollution impact on waterbodies.**
- **Blasting and spray painting activities must be sheltered by hanging tarps to block the wind and prevent dust and overspray from escaping. Move the activity indoors if possible. See Chapter 6 for details on Puget Sound Clean Air Agency limitations.**
- **Ground cloths must be used for collection of drips and spills in painting and finishing operations, and paint chips and used blasting sand from sand blasting.**
- **Bilge water must be collected for proper disposal rather than discharged on land or water. See BMP S.2 in Chapter 5 for detail on disposal options. Several companies are available for bilge pumpout services. The problem can be avoided if oil-absorbent pads are used to capture the oil in the bilge water before or during pumping. If pads are used, they must be recycled or properly disposed.**
- **Ballast water that has an oily sheen on the surface must be collected for proper disposal rather than discharged on land or water. See BMP S.2 in Chapter 5 for details on disposal options.**
- **Maintenance yard areas must be swept and cleaned, without hosing down the area, at least once per week or as needed. This prevents sandblasting materials, scrapings, paint chips, oils, and other loose debris from being carried away with stormwater. The collected materials must be disposed of properly. See BMP S.2 in Chapter 5 for disposal options.**
- **Docks and boat ramps must be swept at least once per week or as needed, and the collected materials must be disposed of properly. Dry docks must be swept before flooding.**

- **Paint and solvent mixing, fuel mixing and similar handling of liquids shall be performed on shore, or such that no spillage can occur directly into surface waterbodies.**
- **Routine cleanup materials such as oil-absorbent pads, brooms, dustpans, mops, buckets, and sponges must be stocked near docks.**
- **When washing your boat in the water, use no soaps or detergents. Brush the hull with water only.**
- **Comply with BMP A2.3 and A4.2 if engine repair and maintenance are conducted.**

### **Recommended BMPs**

The following BMPs are not required but can provide additional pollution protection:

- Boat construction and structural repair activities should be covered.
- Materials such as paints, tools, and ground cloths should be stored indoors or in a covered area when not in use.
- Select the least toxic anti-fouling paint available.
- Boat interiors should be routinely cleaned, with proper disposal of collected materials, so that accumulations of water drained from them are not contaminated.
- Use sanders that have dust containment bags and avoid sanding in windy conditions.
- All used oil should be recycled if feasible. Most marinas now offer used oil recycling services. To dispose of filters, let drain 24 hours, then double wrap in plastic and dispose in the regular garbage, or take them to the Tacoma Landfill Household Hazardous Waste facility for recycling. Pending state legislation may make disposal in the garbage illegal, so call the Hazardous Waste Line at 1-800-287-6429 for current information.
- Citizens for a Healthy Bay, a local environmental group, provides “Clean Bay Boating Kits.” Call them at 253-383-2429 to obtain a free kit.
- Check with marinas for other BMPs they have developed.
- Use one of the following treatment BMPs when paint chips or blasting grit are prevalent in the work area
  - Catch basin filter insert.
  - Infiltration basin.
  - Wet pond or vault.
  - Constructed wetland.
  - Vegetated biofilter.
  - Filtration with media designed for the pollutants that are present.
  - Or equivalent BMP, see Volume V.



## A7.4 LOGGING

**Description of Pollutant Sources:** This activity covers logging activities that fall under the Washington State Forest Practices Act category of Class IV general forest practices. These are situations where timber harvesting is done in the process of converting forest lands into other land uses, such as home and business construction. Stormwater runoff from bare ground can be loaded with dirt and other pollutants. This material can clog ditches and stream channels, thus reducing carrying capacity and increasing flooding, as well as smothering spawning beds for fish. Simply controlling runoff and not allowing it to leave the site will prevent these harmful effects. Clearing and grading activities are covered in detail in Volume II of this Manual, Construction Stormwater Pollution Prevention. Grading activities are also regulated in the City of Tacoma by the Grading and Excavation Code, Section 2.02.330 of the official code of the City of Tacoma.

An NPDES permit is needed from the Washington state Department of Ecology (Ecology) where five (5) or more acres of land is disturbed. Beginning in 2003, coverage under Ecology's General Permit will be required for construction sites that result in the disturbance of one acre or more of land. Compliance with the Construction Stormwater Pollution Prevention requirements in Ecology's manual is required, as applicable. Virtually all logging operations will require a permit from the Washington State Department of Natural Resources. Sensitive/critical areas and wetlands ordinances for Tacoma also contain requirements for logging activities in the vicinity of waterbodies.

Pollutants of concern include suspended solids, oils and greases, biochemical oxygen demand (BOD), nutrients, toxic organic compounds and heavy metals.

**Pollutant Control Approach:** Maintain required buffers adjacent to critical areas, including streams and wetlands. Keep sediments out of waterbodies and off paved areas.

### Required BMPs

- **Vegetation along stream corridors, and adjacent to other waterbodies and wetlands, must be preserved. Maintenance of a vegetated buffer enables filtration of most of the pollutants of concern for this activity. The above-mentioned ordinances contain specific requirements for buffer setbacks.**
- **Logging access roads must have a crushed rock or spall apron construction entrance where they join the pavement to prevent sediments from being tracked onto the pavement.**
- **On-site fueling and maintenance operations must follow the required BMPs as outlined in A2.4 Mobile Fueling, A2.3 Engine Repair and Maintenance and A.4.2 Storage of Liquid Chemicals, Waste Oils, Solvents or Petroleum Products in Portable Containers.**

## **Recommended BMPs**

The following BMPs are not required but can provide additional pollution protection:

- Erosion potential can be reduced by avoiding logging on steep slopes.
- If access roads are constructed for logging, they should be provided with drainage ditches that divert runoff into vegetated areas or stormwater treatment systems.
- Plant vegetated buffers in areas where they are already lost downslope of proposed logging areas, with sufficient lead time to allow for effective growth.

## **A7.5 MINING AND QUARRYING OF SAND, GRAVEL, ROCK, PEAT, CLAY AND OTHER MATERIALS**

**Description of Pollutant Sources:** This activity applies to surface excavation and on-site storage of sand, gravel and other materials that are mined. All mining operations that have stormwater runoff from the site are required to apply for a National Pollutant Discharge Elimination System (NPDES) permit with the Department of Ecology. Ecology has specific BMPs required by the permit. Some additional BMPs to help meet Ecology's discharge performance standards are listed below.

Pollutants of concern are suspended solids, nutrients, pH and metals.

**Pollutant Control Approach:** Provide containment and or cover for any on-site storage areas to prevent run-on and discharge of suspended solids and other pollutants.

### **Recommended BMPs**

The following BMPs are not required, but can be used to provide pollution protection in addition to other requirements:

- If the material is appropriate, use excavated spoil material to form compacted berms along downslope sides of the site to contain runoff. Berms should be seeded to promote growth of grass or other vegetation to limit erosion from the berms. Safety considerations must be examined to prevent flooding due to berm failure.
- Semi-permanent stockpiles should be seeded to promote vegetation growth to limit erosion from the stockpiles.
- Use detention ponds to promote settling of suspended solids, or infiltration basins to filter suspended solids, to clean up runoff before it leaves the site. Refer to Volume V for more information.
- Use anchored tarps to cover stockpiles at small-scale mining operations, if there is a potential for contaminated stormwater to leave the site.

## **A7.6 SWIMMING POOL AND SPA CLEANING AND MAINTENANCE**

**Description of Pollutant Sources:** This activity applies to all municipal and commercial swimming pools and spas, including Tacoma-Pierce County Health Department (TPCHD) regulated facilities. Pools and spas at hotels, motels, apartment and condominium complexes are covered here. Pools at single-family residences are covered in Chapter 3 of this BMP manual. Commercial pool and spa cleaning services must follow these required BMPs for all pools they service.

Pollutants of concern include nutrients, suspended solids, chlorine, pH and chemical oxygen demand (COD).

**Pollutant Control Approach:** Dispose of pool or spa water to the sanitary sewer.

### **Required BMPs**

- **The preferred method of pool or spa water disposal is to the sanitary sewer. If a sanitary sewer is available, all TPCHD regulated facilities are required to connect for draining and backwash. Contact the Tacoma Sanitary Source Control Unit at 253-591-5588 for specific instructions on allowable flow rates and timing before starting to drain the pool. Never discharge pool water to a septic system, as it will cause the system to fail.**
- **If discharge to the sanitary sewer is not possible, pool and spa water may be discharged to a ditch or storm drainage system provided that the water has been dechlorinated first. You are required to contact Tacoma Stormwater Source Control Unit at 253-591-5588 prior to discharge for instructions on allowable flow rates for the system or ditch that is being discharged to. Neutralizing chemicals are available for dechlorinating water. Letting the pool or spa "sit" may also reduce chlorine levels. Use a test kit to determine if the concentration has reached zero.**
- **State law allows discharges of pool water to the ground, not to a water body or storm drainage system, with a chlorine level of up to 3 parts per million. However, the water must not cross property lines or impact neighboring properties, and a satisfactory means for distributing the water to the ground must be used so there is no runoff.**
- **Diatomaceous earth used in pool filters cannot be discharged to surface waters, storm drainage systems, septic systems, or on the ground.**

### **Recommended BMPs**

The following BMPs are not required, but can provide additional pollution protection:

- Hire a professional pool-draining service to collect all pool water for offsite disposal.

## A7.7 DEICING AND ANTI-ICING OPERATIONS FOR AIRPORTS AND STREETS

**Description of Pollutant Sources:** Deicing and/or anti-icing compounds are used on highways, streets, airport runways, and on aircraft to control ice and snow. Typically ethylene glycol and propylene glycol are deicers used on aircraft. Deicers commonly used on highways and streets include calcium magnesium acetate (CMA), calcium chloride, magnesium chloride, sodium chloride, urea, and potassium acetate. The deicing and anti-icing compounds become pollutants when they are conveyed to storm drains or to surface water after application. Leaks and spills of these chemicals can also occur during their handling and storage.

### ***BMPs for Airport De/anti-icing Operations***

**Pollutant Control Approach for Aircraft:** Spent glycol discharges in aircraft application areas are process wastewaters that are regulated under Ecology's industrial stormwater general permit. (Contact the Ecology Regional Office for details.) BMPs for aircraft de/anti-icers must be consistent with aviation safety and the operational needs of the aircraft operator.

*EPA is currently studying airport deicing as part of the pretreatment regulations (40 CFR 403). These regulations are not expected to be promulgated for several years.*

### **Required BMPs for Aircraft:**

- **Conduct aircraft deicing or anti-icing applications in impervious containment areas. Collect aircraft deicer or anti-icer spent chemicals, such as glycol, draining from aircraft in deicing or anti-icing application areas and convey to a sanitary sewer, treatment, or other approved disposal or recovery method. Divert deicing runoff from paved gate areas to appropriate collection areas or conveyances for proper treatment or disposal.**
- **Do not allow spent deicer or anti-icer chemicals or stormwater contaminated with aircraft deicer or anti-icer chemicals to be discharged from application areas including gate areas, to surface water, or ground water, directly or indirectly.**
- **Transfer deicing and anti-icing chemicals on an impervious containment pad, or equivalent spill/leak containment area, and store in secondary containment areas. (See Storage of Liquids in Above-Ground Tanks)**

### **Recommended BMPs for Aircraft:**

- Establish a centralized aircraft de/anti-icing facility, if feasible and practicable, or in designated areas of the tarmac equipped with separate collection drains for the spent deicer liquids.
- Consider installing an aircraft de/anti-icing chemical recovery system, or contract with a chemical recycler, if practicable.

*Note the applicable containment BMP of aircraft de/anti-icing applications, and applicable treatment BMPs for de/anti-icer spent chemicals such as glycols.*

### **Required BMPs for Airport Runways/Taxiways:**

- **Avoid excessive application of all de/anti-icing chemicals, which could contaminate stormwater.**
- **Store and transfer de/anti-icing materials on an impervious containment pad or an equivalent containment area and/or under cover in accordance with BMP Storage or Transfer (Outside) of Solid Raw Materials, By-Products, or Finished Products in this volume. Other material storage and transfer approaches may be considered if it can be demonstrated that stormwater will not be contaminated with or that the de/anti-icer material cannot reach surface or ground waters.**

### **Recommended BMPs for Airport Runways/Taxiways:**

- Include limits on toxic materials and phosphorous in the specifications for de/anti-icers, where applicable.
- Consider using anti-icing materials rather than deicers if it will result in less adverse environmental impact.
- Select cost-effective de/anti-icers that cause the least adverse environmental impact.

### ***BMPs for Streets/Highways***

#### **Required BMPs for Streets/Highways**

- **Select de and anti-icers that cause the least adverse environmental impact. Apply only as needed using minimum quantities.**
- **Where feasible and practicable use roadway deicers, such as calcium magnesium acetate, potassium acetate, or similar materials, that cause less adverse environmental impact than urea, and sodium chloride.**
- **Store and transfer de/anti-icing materials on an impervious containment pad in accordance with BMP Storage or Transfer (Outside) of Solid Raw Materials, By-Products, or Finished Products in this volume.**
- **Sweep/clean up accumulated de/anti-icing materials and grit from roads as soon as possible after the road surface clears.**

#### **Recommended BMPs for Streets/Highways**

- Intensify roadway cleaning in early spring to help remove particulates from road surfaces.
- Include limits on toxic metals in the specifications for de/anti-icers.

## **A7.8 ROOF AND BUILDING DRAINS AT MANUFACTURING AND COMMERCIAL BUILDINGS**

**Description of Pollutant Sources:** Stormwater runoff from roofs and sides of manufacturing and commercial buildings can be sources of pollutants caused by leaching of roofing materials, building vents, and other air emission sources. Vapors and entrained liquid and solid droplets/particles have been identified as potential pollutants in roof/building runoff. Metals, solvents, acidic/alkaline pH, BOD, and organics, are some of the pollutant constituents identified.

**Pollutant Control Approach:** Evaluate the potential sources of stormwater pollutants and refer the business to the Puget Sound Clean Air Agency for the application of source control BMPs.

### **Required BMPs**

**These required source control BMPs will be addressed by the Puget Sound Clean Air Agency.**

- **If leachates and/or emissions from buildings are suspected sources of stormwater pollutants, then sample and analyze the stormwater draining from the building.**
- **If a roof/building stormwater pollutant source is identified, implement appropriate source control measures such as air pollution control equipment, selection of materials, operational changes, material recycle, process changes, etc.**

## A7.9 URBAN STREETS

**Description of Pollutant Sources:** Streets can be the sources of vegetative debris, paper, fine dust, vehicle liquids, tire wear residues, heavy metals (lead and zinc), soil particles, ice control salts, domestic wastes, lawn chemicals, and vehicle combustion products. Street surface contaminants have been found to contain significant concentrations of particle sizes less than 250 microns. (Sartor and Boyd, 1972)

**Pollutant Control Approach:** Conduct efficient street sweeping where and when appropriate to minimize the contamination of stormwater. Do not wash street debris into storm drains.

### Recommended BMPs

- For maximum stormwater pollutant reductions on curbed streets and high volume parking lots use efficient vacuum sweepers (refer to Volume V, Ch. 12 of this manual, for information about an emerging high-efficiency vacuum sweeper technology).

*Note: High-efficiency street sweepers utilize strong vacuums and the mechanical action of main and gutter brooms combined with an air filtration system that only returns clean air to the atmosphere (i.e., filters very fine particulates). They sweep dry and use no water since they do not emit any dust.*

*It has been reported that high-efficiency vacuum sweepers have the capability of removing, from pavements under good condition, 80 percent or more of the accumulated street dirt particles whose diameters are less than 250 microns. (Sutherland, 1998) This assumes pavements under good condition and reasonably expected accumulation conditions.*

- For moderate stormwater pollutant reductions on curbed streets use regenerative air sweepers or tandem sweeping operations.

*Note: A tandem sweeping operation involves a single pass of a mechanical sweeper followed immediately by a single pass of a vacuum sweeper or regenerative air sweeper.*

- *A regenerative air sweeper blows air down on the pavement to entrain particles and uses a return vacuum to transport the material to the hopper.*
- *These operations usually use water to control dust. This reduces their ability to pick up fine particulates.*

*It has been reported that these types of sweepers have the capability of removing approximately 25 to 50 percent of the accumulated street dirt particles whose diameters are less than 250 microns. (Sutherland, 1998) This assumes pavements under good conditions and typical accumulation conditions.*

- For minimal stormwater pollutant reductions on curbed streets use mechanical sweepers.
  - *Note: Mechanical sweepers are referred to as broom sweepers and use the mechanical action of main and gutter brooms to throw material on a conveyor belt that transports it to the hopper.*
  - *These sweepers usually use water to control dust. This reduces their ability to pick up fine particulates.*



*It has been reported that mechanical sweepers have the capability of removing only 10 to 20 percent of the accumulated street dirt particles whose diameters are less than 250 microns. (Sutherland, 1998) This assumes pavements under good condition and the most favorable accumulation conditions.*

- Conduct sweeping at optimal frequencies. Optimal frequencies are those scheduled sweeping intervals that produce the most cost-effective annual reduction of pollutants normally found in stormwater and can vary depending on land use, traffic volume and rainfall patterns.
- Train operators in those factors that result in optimal pollutant removal. These factors include sweeper speed, brush adjustment and rotation rate, sweeping pattern, maneuvering around parked vehicles, and interim storage and disposal methods.
- Consider the use of periodic parking restrictions in low to medium density single-family residential areas to ensure the sweeper's ability to sweep along the curb.
- Establish programs for prompt sweeping, removal, and disposal of debris from special events that will generate higher than normal loadings.
- Disposal of street sweeping solids must comply with "Recommendations for Management of Street Wastes" described in Appendix IV-C of this volume.
- Inform citizens about the importance of NOT putting yard debris, oil and other wastes in street gutters in order to reduce street pollutant sources.

## **A7.10 RAILROAD YARDS**

**Description of Pollutant Sources:** Pollutant sources can include drips/leaks of vehicle fluids onto the railroad bed, human waste disposal, litter, locomotive/railcar/equipment cleaning areas, fueling areas, outside material storage areas, the erosion and loss of soil particles from the railroad bed, maintenance and repair activities at railroad terminals, switching yards, and maintenance yards, and herbicides used for vegetation management. Waste materials can include waste oil, solvents, degreasers, antifreeze solutions, radiator flush, acids, brake fluids, soiled rags, oil filters, sulfuric acid and battery sludges, and machine chips with residual machining oil and toxic fluids/solids lost during transit. Potential pollutants include oil and grease, TSS, BOD, organics, pesticides, and metals.

**Pollutant Control Approach:** Apply good housekeeping and preventive maintenance practices to control leaks and spills of liquids in railroad yard areas.

### **Required BMPs**

- **Implement the applicable BMPs in this chapter depending on the pollutant generating activities/sources at a railroad yard facility.**
- **Do not allow discharge to outside areas from toilets while a train is in transit. Pumpout facilities should be used to service these units.**
- **Use drip pans at hose/pipe connections during liquid transfer and other leak-prone areas.**
- **During maintenance do not discard debris or waste liquids along the tracks or in railroad yards.**

**In areas subjected to leaks/spills of oils or other chemicals convey the contaminated stormwater to appropriate treatment such as a sanitary sewer, if approved by the City of Tacoma, or, to a CP or API oil/water separator for floating oils, or other appropriate treatment BMP. See Volume V.**

## **A7.11 MAINTENANCE OF PUBLIC AND UTILITY CORRIDORS AND FACILITIES**

**Description of Pollutant Sources:** Passageways and equipment at petroleum product, natural gas, and water pipelines, and electrical power transmission corridors and rights-of-way can be sources of pollutants such as herbicides used for vegetation management, and eroded soil particles from unpaved access roads. At pump stations waste materials generated during maintenance activities may be temporarily stored outside. Additional potential pollutant sources include the leaching of preservatives from wood utility poles, PCBs in older transformers, water that is removed from underground transformer vaults, and leaks/spills from petroleum pipelines. The following are potential pollutants: oil and grease, TSS, BOD, organics, PCB, pesticides, and heavy metals.

**Pollutant Control Approach:** Control of fertilizer and pesticide applications, soil erosion, and site debris that can contaminate stormwater.

### **Required BMPs**

- **Implement BMPs included in Chapter 4, A.9 Landscaping and Lawn/Vegetation Management and in Chapter 6, Section 6.2, R.6, Pesticide Regulations.**
- **When water or sediments are removed from electric transformer vaults, determine whether contaminants might be present before disposing of the water and sediments. This includes inspecting for the presence of oil or sheen, and determining from records or testing if the transformers contain PCBs. If records or tests indicate that the sediment or water are contaminated above applicable levels, manage these media in accordance with applicable federal and state regulations, including the federal PCB rules (40 CFR 761) and the state MTCA cleanup regulations (Chapter 173-340 WAC). Water removed from the vaults can be discharged in accordance with the federal 40 CFR 761.79, and state regulations (Chapter 173-201A WAC and Chapter 173-200 WAC), or via the sanitary sewer if the requirements, including applicable permits, for such a discharge are met. (See also Chapter 6, Section 6.2-R2).**
- **Within utility corridors, consider preparing maintenance procedures and an implementation schedule that provides for vegetative, gravel, or equivalent cover that minimizes bare or thinly vegetated ground surfaces within the corridor, to prevent the erosion of soil.**
- **Provide maintenance practices to prevent stormwater from accumulating and draining across and/or onto roadways. Stormwater should be conveyed through roadside ditches and culverts. The road should be crowned, outsloped, water barred or otherwise left in a condition not conducive to erosion. Appropriately maintaining grassy roadside ditches discharging to surface waters is an effective way of removing some pollutants associated with sediments carried by stormwater.**
- **Maintain ditches and culverts at an appropriate frequency to ensure that plugging and flooding across the roadbed, with resulting overflow erosion, does not occur.**
- **Apply the appropriate BMPs from Section A4 of this Volume, Storage Activities, for the storage of waste materials that can contaminate stormwater.**

## **Recommended BMPs**

- When selecting utility poles for a specific location, consideration should be given to the potential environmental effects of the pole or poles during storage, handling, and end-use, as well as its cost, safety, efficacy and expected life. If a wood product treated with chemical preservatives is used, it should be made in accordance with generally accepted industry standards such as the American Wood Preservers Association Standards. If the pole or poles will be placed in or near an environmentally sensitive area, such as a wetland or a drinking water well, alternative materials or technologies should be considered. These include poles constructed with material(s) other than wood such as fiberglass composites, metal, or concrete. Other technologies and materials, such as sleeves or caissons for wood poles, may also be considered when they are determined to be practicable and available.
- As soon as practicable remove all litter from wire cutting/replacing operations, etc.
- Implement temporary erosion and sediment control in areas where clear-cuts are conducted and new roads are constructed.

## **A7.12 MAINTENANCE OF ROADSIDE DITCHES**

**Description of Pollutant Sources:** Common road debris including eroded soil, oils, vegetative particles, and heavy metals can be sources of stormwater pollutants.

**Pollutant Control Approach:** Roadside ditches should be maintained to preserve the condition and capacity for which they were originally constructed, and to minimize bare or thinly vegetated ground surfaces. Maintenance practices should provide for erosion and sediment control (Refer to Activity A3.6 Landscaping and Lawn/Vegetation Management).

### **Required BMPs**

- **Inspect roadside ditches regularly, as needed, to identify sediment accumulations and localized erosion.**
- **Clean ditches on a regular basis, as needed. Ditches should be kept free of rubbish and debris.**
- **Vegetation in ditches often prevents erosion and cleanses runoff waters. Remove vegetation only when flow is blocked or excess sediments have accumulated. Conduct ditch maintenance (seeding, fertilizer application, harvesting) in late spring and/or early fall, where possible. This allows vegetative cover to be re-established by the next wet season thereby minimizing erosion of the ditch as well as making the ditch effective as a biofilter.**
- **In the area between the edge of the pavement and the bottom of the ditch, commonly known as the “bare earth zone,” use grass vegetation, wherever possible. Vegetation should be established from the edge of the pavement if possible, or at least from the top of the slope of the ditch.**
- **Diversion ditches on top of cut slopes, that are constructed to prevent slope erosion by intercepting surface drainage, must be maintained to retain their diversion shape and capability.**
- **Ditch cleanings are not to be left on the roadway surfaces. Sweep dirt and debris remaining on the pavement at the completion of ditch cleaning operations.**
- **Roadside ditch cleanings, not contaminated by spills or other releases and not associated with a stormwater treatment system such as a bioswale, may be screened to remove litter and separated into soil and vegetative matter (leaves, grass, needles, branches, etc.). The soil fraction may be handled as ‘clean soils’ and the vegetative matter can be composted or disposed of in a municipal waste landfill. For more information, please see “Recommendations for Management of Street Wastes,” in Appendix IV-C of this volume.**
- **Roadside ditch cleanings contaminated by spills or other releases known or suspected to contain dangerous waste must be handled following the Dangerous Waste Regulations (Chapter 173-303 WAC) unless testing determines it is not dangerous waste.**

- **Inspect culverts on a regular basis for scour or sedimentation at the inlet and outlet, and repair as necessary. Give priority to those culverts conveying perennial and/or salmon-bearing streams and culverts near streams in areas of high sediment load, such as those near subdivisions during construction.**

#### **Recommended BMPs**

- Install biofiltration swales and filter strips to treat roadside runoff wherever practicable and use engineered topsoils wherever necessary to maintain adequate vegetation (CH2M Hill, 2000). These systems can improve infiltration and stormwater pollutant control upstream of roadside ditches. Refer to Volume 5 of this manual, Runoff Treatment BMPs for additional information about biofiltration swales and filter strips.

## **A7.13 MAINTENANCE OF STORMWATER DRAINAGE AND TREATMENT FACILITIES**

**Description of Pollutant Sources:** Facilities include roadside catch basins on arterials and within residential areas, conveyance systems, detention facilities such as ponds and vaults, oil and water separators, biofilters, settling basins, infiltration systems, and all other types of stormwater treatment systems presented in Volume V. Roadside catch basins can remove from 5 to 15 percent of the pollutants present in stormwater. When catch basins are about 60 percent full of sediment, they cease removing sediments. Oil and grease, hydrocarbons, debris, heavy metals, sediments and contaminated water are found in catch basins, oil and water separators, settling basins, etc.

**Pollutant Control Approach:** Provide maintenance and cleaning of debris, sediments, and oil from stormwater collection, conveyance, and treatment systems to obtain proper operation.

### **Required BMPs**

**Maintain stormwater treatment facilities according to the O & M procedures presented in Section 4.6 of Volume V of this manual, in addition to the following BMPs:**

- **Inspect and clean treatment BMPs, conveyance systems, and catch basins as needed, and determine whether improvements in O & M are needed.**
- **Promptly repair any deterioration threatening the structural integrity of the facilities. These include replacement of clean-out gates, catch basin lids, and rock in emergency spillways.**
- **Ensure that storm sewer capacities are not exceeded and that heavy sediment discharges to the sewer system are prevented.**
- **Regularly remove debris and sludge from BMPs used for peak-rate control, treatment, etc. and discharge to a sanitary sewer if approved by the City of Tacoma, or truck to a local or state government approved disposal site.**
- **Clean catch basins in accordance with the information provided in Volume V, Runoff Treatment BMPs, Section 4.6, number 5. Additional information is also included in Chapter 5 of this volume, BMP S.9 Cleaning Catch Basins.**
- **Clean woody debris in a catch basin as frequently as needed to ensure proper operation of the catchbasin.**
- **Post warning signs; “Dump No Waste - Drains to Ground Water,” “Streams,” “Lakes,” or emboss on or adjacent to all storm drain inlets *where practical*.**
- **Disposal of sediments and liquids from the catch basins must comply with “Recommendations for Management of Street Wastes” described in Appendix IV-C of this volume.**

- **Select additional applicable BMPs from this chapter depending on the pollutant sources and activities conducted at the facility. Those BMPs include:**
  - **A4.7 - BMPs for Storage of Liquid, Food Waste, or Dangerous Waste Containers**
  - **A6.3 - BMPs for Soil Erosion and Sediment Control at Industrial Sites**
  - **A7.9 - BMPs for Urban Streets**
  - **A7.14 - BMPs for Spills of Oil and Hazardous Substances**
  - **S1 - BMPs for Illicit Connections to Storm Drains**



## **A7.14 SPILLS OF OIL AND HAZARDOUS SUBSTANCES**

**Description of Pollutant Sources:** Owners or operators of facilities engaged in drilling, producing, gathering, storing, processing, transferring, distributing, refining or consuming oil and/or oil products are required by Federal Law to have a Spill Prevention and Control Plan if the storage capacity of the facility, which is not buried, is 1,320 gallons or more of oil, or any single container with a capacity in excess of 660 gallons and which, due to their location, could reasonably be expected to discharge oil in harmful quantities, as defined in 40 CFR Part 110, into or upon the navigable waters of the United States or adjoining shorelines {40 CFR 112.1 (b)}. Onshore and offshore facilities, which, due to their location, could not reasonably be expected to discharge oil into or upon the navigable waters of the United States or adjoining shorelines are exempt from these regulations {40 CFR 112.1(1)(i)}. Owners of businesses that produce Dangerous Wastes are also required by State Law to have a spill control plan. These businesses should refer to Chapter 6, Section 6.2, R-2. The federal definition of oil is oil of any kind or any form, including, but not limited to petroleum, fuel oil, sludge, oil refuse, and oil mixed with wastes other than dredged spoil.

**Pollutant Control Approach:** Maintain, update, and implement an oil spill prevention/cleanup plan.

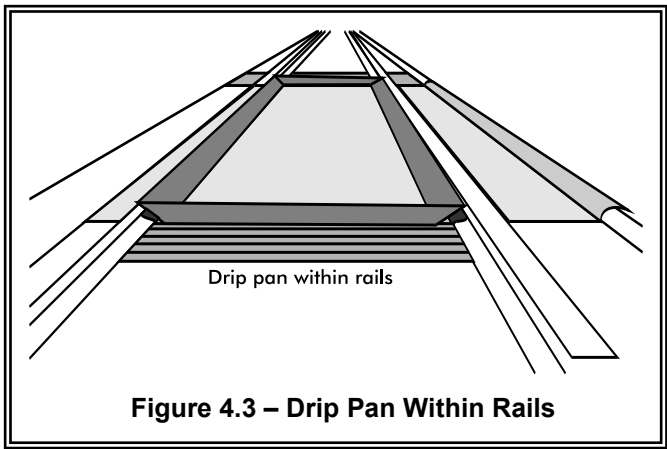
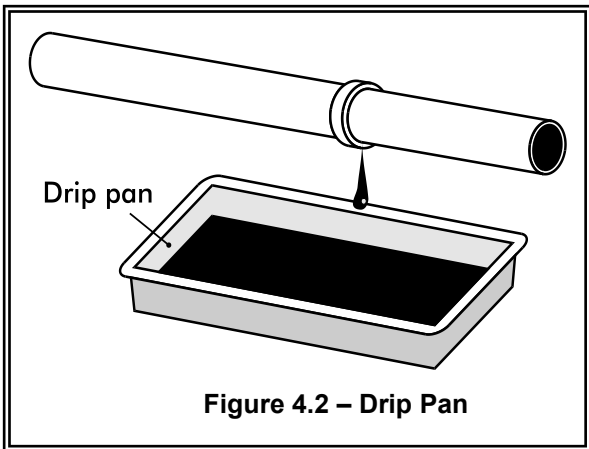
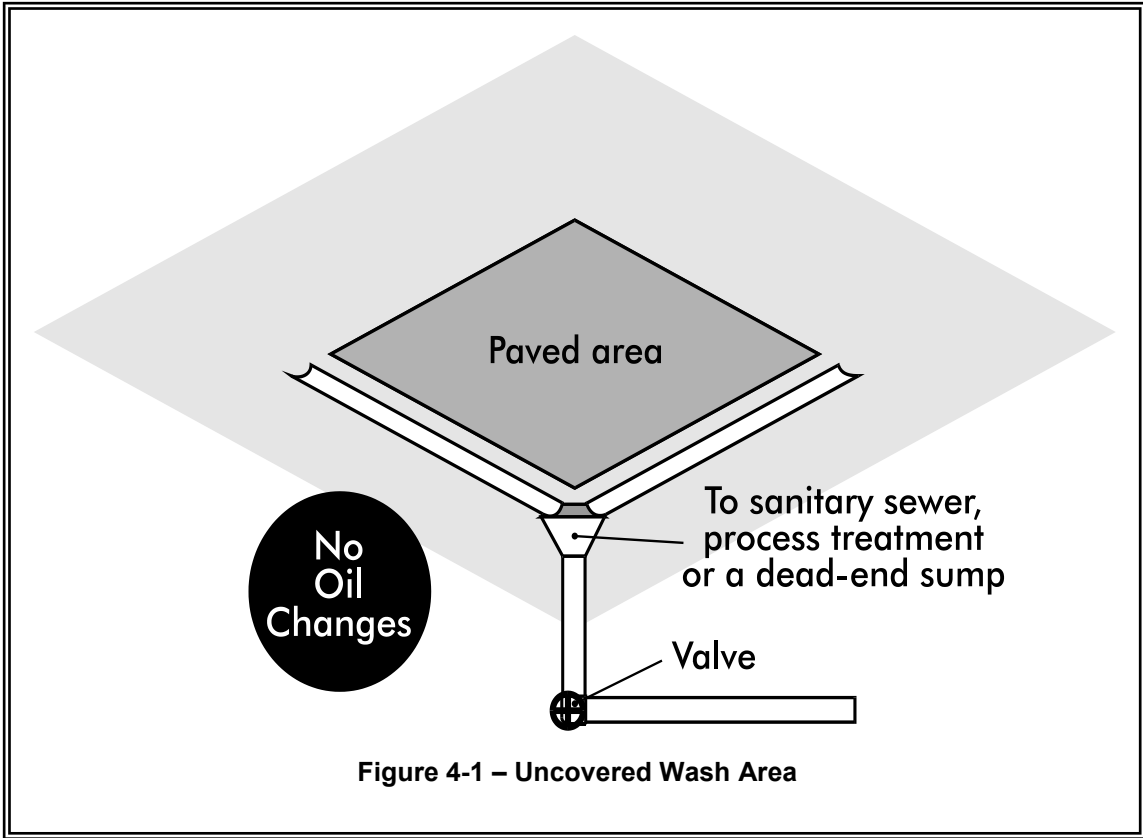
### **Required BMPs**

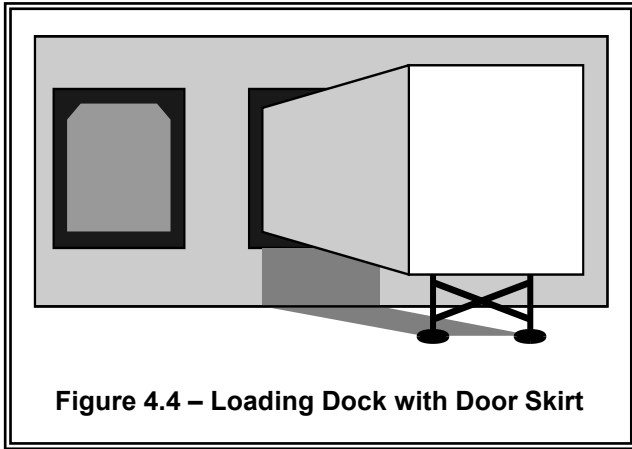
- **Prepare an Emergency Spill Control Plan (SCP), which includes:**
  - **A description of the facility including the owner's name and address;**
  - **The nature of the activity at the facility;**
  - **The general types of chemicals used or stored at the facility;**
  - **A site plan showing the location of storage areas for chemicals, the locations of storm drains, the areas draining to them, and the location and description of any devices to stop spills from leaving the site such as positive control valves;**
  - **Cleanup procedures;**
  - **Notification procedures to be used in the event of a spill, such as notifying key personnel. Agencies such as Ecology, Tacoma Fire Department, Washington State Patrol, City of Tacoma, U.S. Coast Guard and the U.S. Environmental Protection Agency shall be notified;**
  - **The name of the designated person with overall spill cleanup and notification responsibility;**
  
- **Train key personnel in the implementation of the Emergency SCP. Prepare a summary of the plan and post it at appropriate points in the building, identifying the spill cleanup coordinators, location of cleanup kits, and phone numbers of regulatory agencies to be contacted in the event of a spill;**
  
- **Update the SCP regularly;**
  
- **Immediately notify Ecology and the City of Tacoma if a spill may reach sanitary or storm sewers, ground water, or surface water, in accordance with federal and Ecology spill reporting requirements;**
  
- **Immediately clean up spills. Do not use emulsifiers for cleanup unless an appropriate disposal method for the resulting oily wastewater is implemented. Absorbent material shall not be washed down a floor drain or storm sewer; and,**

- **Locate emergency spill containment and cleanup kit(s) in high potential spill areas. The contents of the kit shall be appropriate for the type and quantities of chemical liquids stored at the facility.**

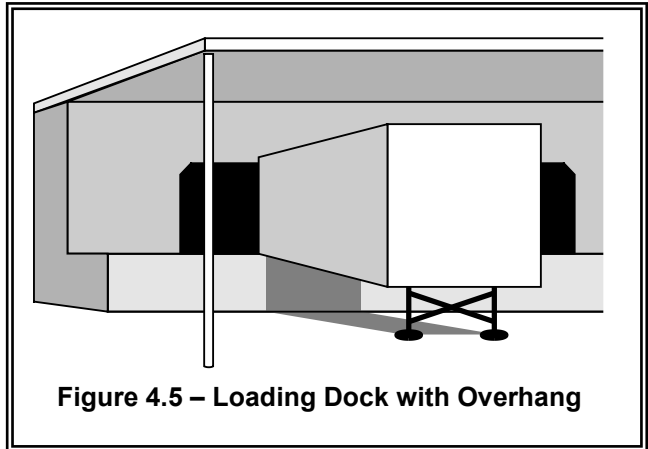
#### **Recommended BMP**

- Spill kits should include appropriately lined drums, absorbent pads, and granular or powdered materials for neutralizing acids or alkaline liquids where applicable. In fueling areas: absorbent should be packaged in small bags for easy use and small drums should be available for storage of absorbent and/or used absorbent. Spill kits should be deployed in a manner that allows rapid access and use by employees.

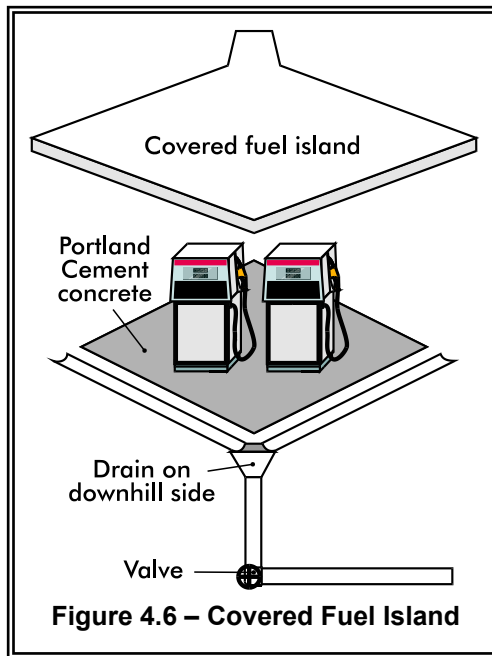




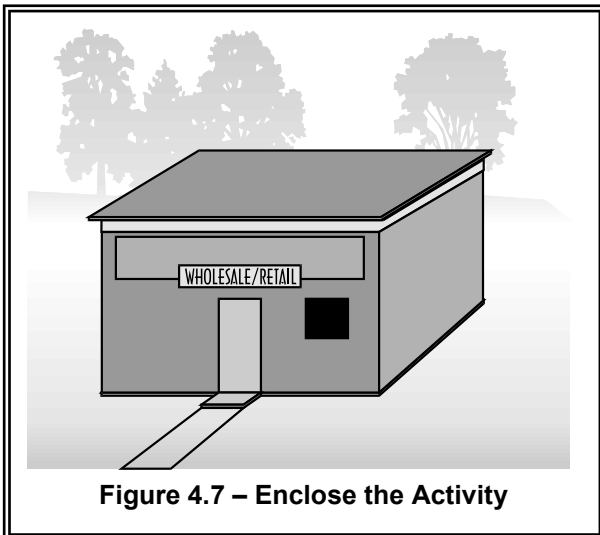
**Figure 4.4 – Loading Dock with Door Skirt**



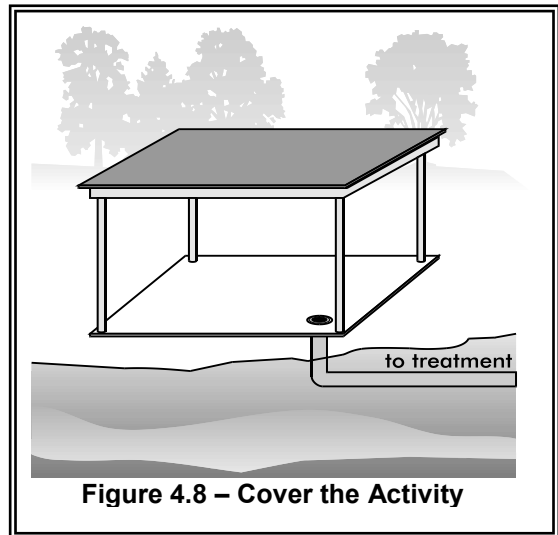
**Figure 4.5 – Loading Dock with Overhang**



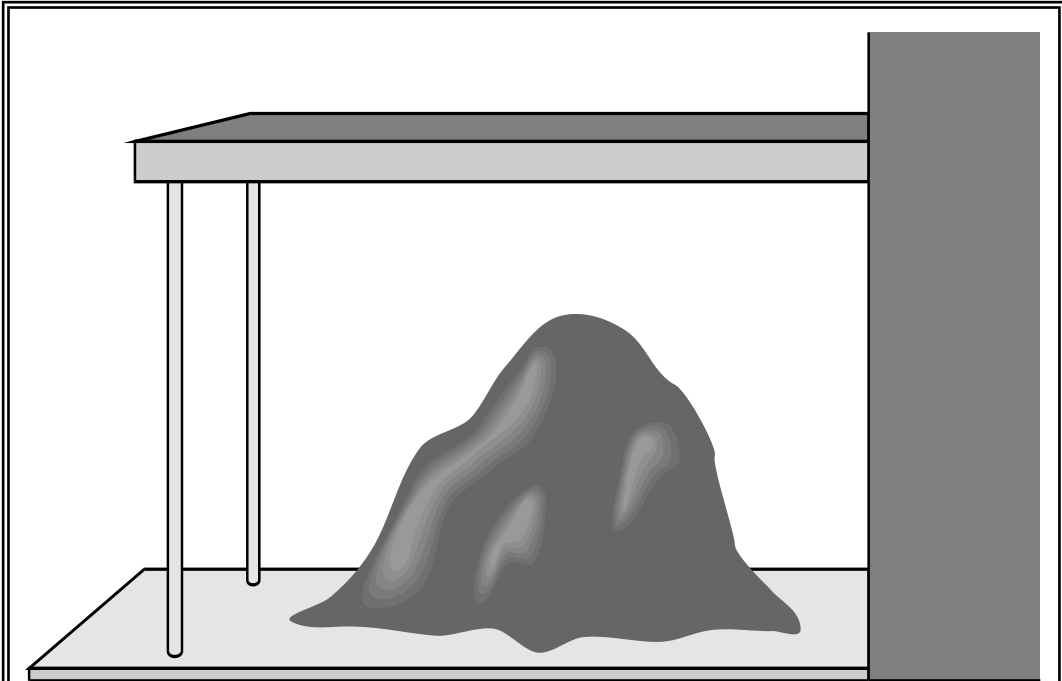
**Figure 4.6 – Covered Fuel Island**



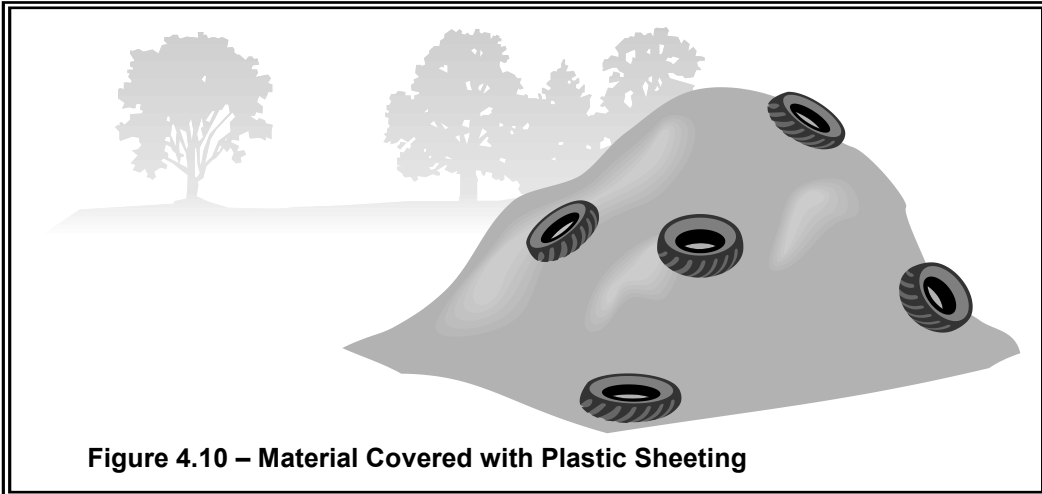
**Figure 4.7 – Enclose the Activity**



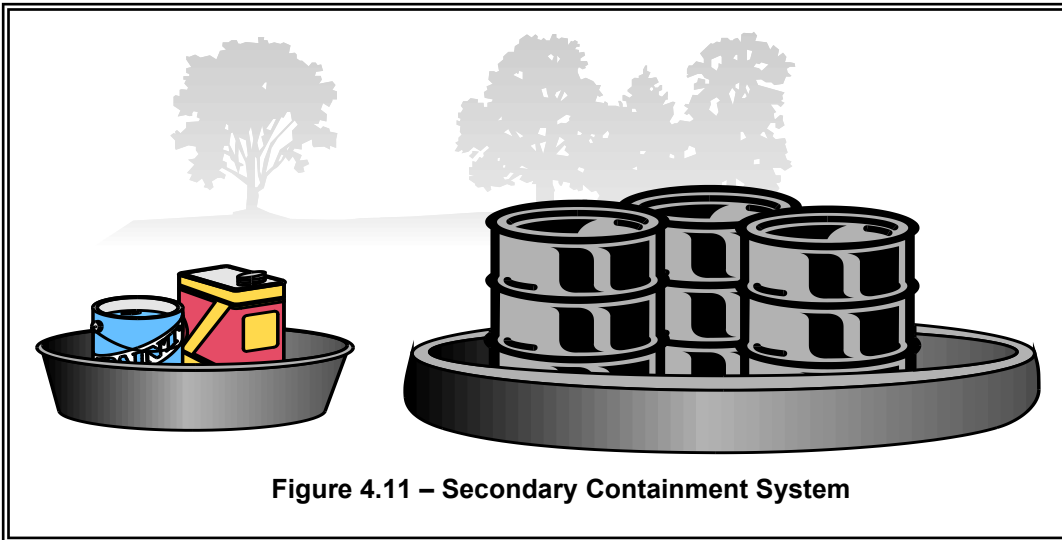
**Figure 4.8 – Cover the Activity**



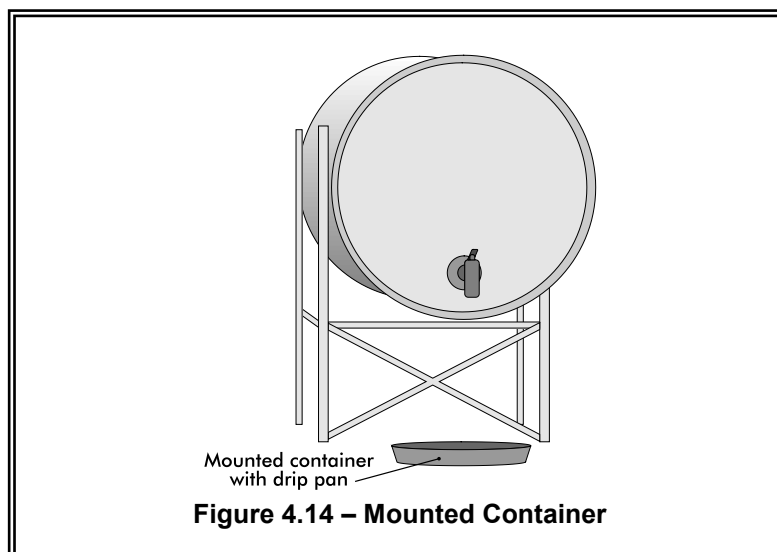
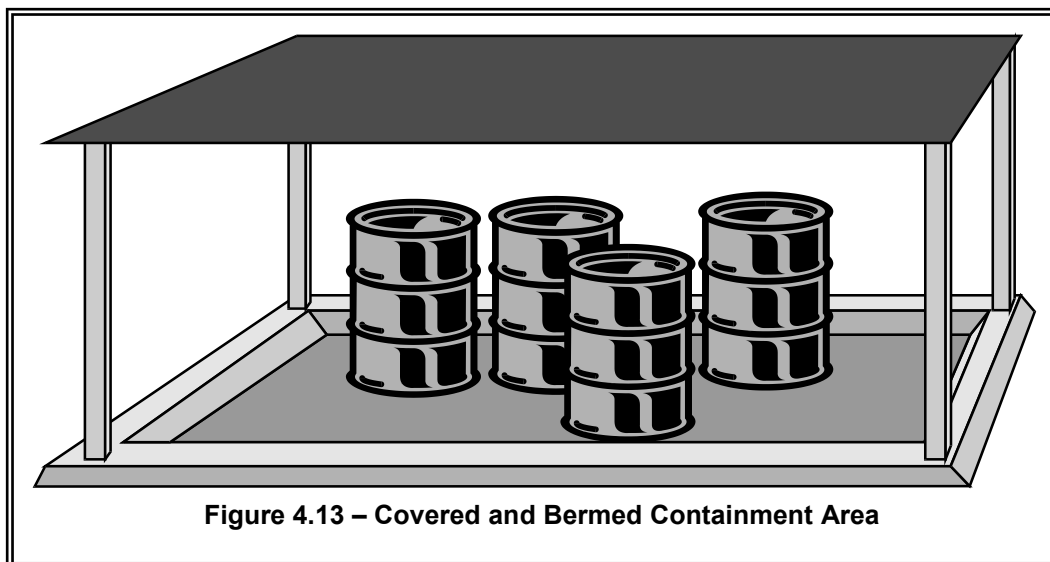
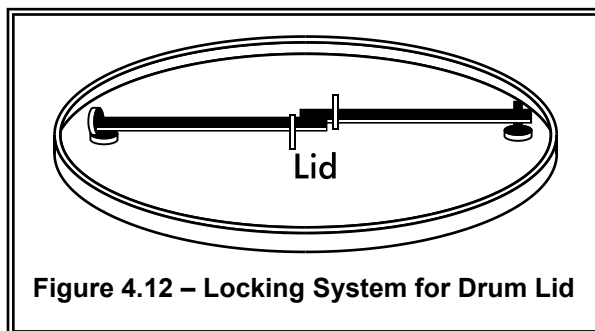
**Figure 4.9 – Covered Storage Area for Bulk Solids (include berm if needed)**

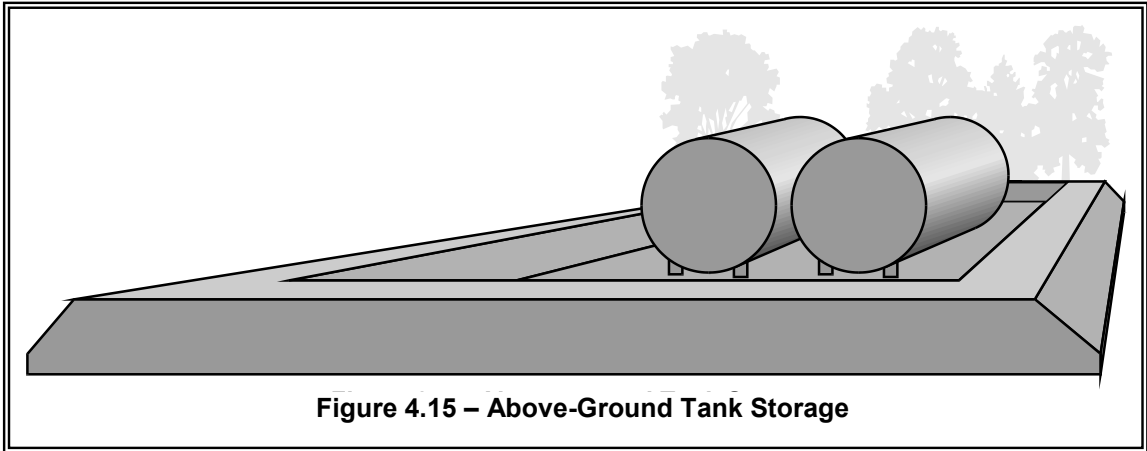


**Figure 4.10 – Material Covered with Plastic Sheeting**



**Figure 4.11 – Secondary Containment System**





# Chapter 5 – Source Control Best Management Practices

---

In the previous chapter, different commercial activities were described and BMPs for pollution prevention were listed. This chapter provides the detailed descriptions of those source control BMPs.

Section 4.3, BMPs to Consider for All Activities, provides a list of general BMPs that each business should consider. Most of these are common sense, housekeeping types of activities, such as spill cleanup, moving activities indoors, and using the least toxic materials available. The implementation of these types of BMPs will help improve water quality.

## 5.1 Index of BMP Descriptions

<b>BMP</b>	<b>DESCRIPTION TITLE</b>
<b>S.1</b>	Eliminate illicit storm drainage system connections
<b>S.2</b>	Dispose of collected runoff and waste materials properly
<b>S.3</b>	Connect process water discharges to a sanitary sewer, holding tank, or water treatment system
<b>S.4</b>	Cover the activity with a roof or awning
<b>S.5</b>	Cover the activity with an anchored tarp or plastic sheet
<b>S.6</b>	Pave the activity area and slope to a sump or holding tank
<b>S.7</b>	Surround the activity area with a curb, dike or berm, or elevate the activity
<b>S.8</b>	Implement integrated pest management measures
<b>S.9</b>	Clean catch basin



## 5.2 Source Control BMPs

### BMP S.1 ELIMINATE ILLICIT STORM DRAIN CONNECTIONS

A common problem with the storm drain system for Tacoma is the existence of illegal hook-ups to the system. Many businesses and residences hooked internal building drains, sump overflows, process wastewater discharges and even sanitary sewer and septic system pipes to the storm drain in the past as a matter of course. These connections allow a variety of pollutants to flow directly to receiving waters instead of to the sanitary sewer or septic system. Frequently, these connections are unknown to the current owner, and do not appear on any plans for the site. Because of the potential to pollute that these connections represent, the Environmental Protection Agency, under the mandate of the National Pollutant Discharge Elimination System (NPDES) stormwater permits, has made the elimination of such illicit connections a top priority.

All businesses and residences in Tacoma must examine their plumbing systems to determine if illicit connections exist. A good place to start would be with site plans. This will help the current owner understand what piping systems were installed initially, making piping that does not appear on the plan a priority for investigation. Any time it is found that toilets, sinks, appliances, showers and bathtubs, floor drains, industrial process waters and all other indoor activities are connected to the storm drainage system, these connections must either be immediately rerouted to the sanitary or septic system, holding tanks, or process treatment system. Exceptions to this requirement would be those industries and businesses that have been issued an NPDES Baseline General Permit by Ecology, and are allowed specific discharges under that permit. Please refer to R.4 in Chapter 6 to determine if your type of business is required to have a NPDES permit.

If it is found that sanitary facilities, such as toilets, are hooked to the storm drain system, you must have permits from your local sewer utility (Tacoma 253-591-5588) to reroute them to the sanitary sewer. If sanitary service is not available, contact the City of Tacoma for a septic permit.

Dye testing with a non-toxic dye is one way of helping to determine where a pipe or structure drains to if it is not obvious by observations or on plans. The dye is put into the structure and flushed with some water. Observations are then made at ends-of-pipes, drainage ditches, catch basins and manholes to look for the color coming through. Contact the Tacoma Source Control Unit at 253-591-5588 if you need assistance in locating city structures adjacent to your property.

Smoke testing can also be used to detect illicit connections. It is typically best done by qualified personnel. All indoor discharges should be shut off before this test is conducted. A smoke bomb or other smoke-generating device is placed in a storm drain manhole, and air is forced in after it. Personnel should be stationed at each suspect drain location to observe if smoke is coming out. Smoking drains should be tagged for future rerouting.

Drains which are found to connect to the storm drainage system must either be permanently plugged or disconnected and rerouted as soon as possible. Drains that are no longer needed can be plugged with concrete or similarly effective permanent materials. If a drain pipe is to be rerouted and a sanitary sewer services the property, then the local sewer district must be contacted. Contact the number listed above for specific directions prior to rerouting. Restrictions on certain types of discharges, particularly industrial process waters, may require pretreatment of discharges before entering the sanitary sewer. It is the responsibility of the property owner or

business operator to follow through on rerouting illicit storm drainage connections to the sanitary sewer.

If the property is not served by a sanitary sewer, alternate measures will be necessary. If the discharge is simply domestic waste, a septic system may be feasible. If it is necessary to install a septic system, the proper permits will need to be obtained from the Tacoma-Pierce County Health Department at 253-798-6470. If the discharge is anything other than domestic waste, then a holding tank or on-site treatment will be necessary. Contact the Tacoma Sanitary Source Control unit at 253-591-5588 for specific directions for installation and disposal.

## **BMP S.2 DISPOSE OF COLLECTED RUNOFF AND WASTE MATERIALS PROPERLY**

Every business and residence in Tacoma must dispose of solid and liquid wastes and contaminated stormwater properly. There are generally four options for disposal depending on the type of materials. These options include:

- Sanitary sewer and septic systems
- Recycling facilities
- Municipal solid waste disposal facilities
- Hazardous waste treatment, storage, and disposal facilities

Many liquid wastes and contaminated stormwater (depending on the pollutants and associated concentrations present) can be put into the sanitary sewer, subject to approval by the local sanitary sewer district. Animal wastes can also be disposed of in a sanitary sewer, subject to loading capacity constraints.

If wastes cannot be legally discharged to a sanitary sewer or septic system, one of the other three disposal options must be used. Sumps or holding tanks may be useful for storing liquid wastes temporarily. The contents must be disposed of in the sanitary sewer or at a dangerous waste facility depending on the nature of the waste.

Recycling facilities are a recommended option for many commercial and household items, including used oils, used batteries, old equipment, glass, some plastics, metal scrap materials, solvents, paints, wood and land clearing wastes, and various other solid wastes. Solid wastes that cannot be recycled and that are not hazardous must be disposed of at a licensed municipal solid waste disposal facility. The list in Chapter 7 of this manual has the phone numbers and addresses of these facilities in Tacoma.

Dangerous and hazardous wastes must be properly transported to an appropriate hazardous waste disposal, treatment and storage facility. Included in Chapter 7 is a list of companies dealing in these activities.

Costs of disposal vary considerably from option to option. Especially in the case of dangerous wastes, the different types of wastes should be kept segregated. Disposal costs are usually determined by the most hazardous or difficult to dispose of waste present, so you can keep your costs down by not mixing wastes. The Tacoma-Pierce County Health Department Hazardous Waste section at 798-6047 can help you determine the best disposal options for your waste.

### **BMP S.3      CONNECT PROCESS WATER DISCHARGES TO A SANITARY SEWER, HOLDING TANK, OR WASTEWATER TREATMENT SYSTEM**

This BMP is a minimum requirement for all industrial and commercial activities that generate contaminated process wastewater, such as washing activities, composting activities, and production and processing activities. The water used in these activities cannot drain to surface waters or groundwater untreated. Process water must drain to a sanitary sewer, holding tank, or wastewater treatment system, or it can be recycled.

The first priority for these businesses is discharge of process water to a sanitary sewer via a new or existing plumbing connection. In order to connect to the sewer, you must contact Tacoma Building and Land Use Services at 591-5030 for information on permits for the connection. Pretreatment of industrial wastewaters will often be necessary before it is allowed to discharge to the sewer. Call Tacoma Sanitary Source Control Unit at 591-5588 for more information.

If a sanitary sewer is not available, or if it is determined that a discharge connection is not allowed, the only remaining options are holding tanks or an on-site wastewater treatment facility. Consideration should be given to using a holding tank for used process water if the volume of process water generated by the activity is not excessive. The contents of the holding tank must be pumped out or drained before the tank is full and disposed of properly (see BMP S.2 in this chapter for information on disposal options). If a sanitary sewer connection cannot be made and a holding tank is not used, a wastewater treatment facility must be constructed on the site. This treatment facility must be designed to receive and effectively treat all discharges of process water from the business. The Washington State Department of Ecology must be contacted for approval of such a facility, since discharges from the treatment facility will enter surface waters or be spread on land. See Chapter 6 for Ecology's requirements for discharges of process waters.

For all types of process water discharges the following measures are required if the activity is to remain uncovered. Define a designated area for the activity and provide a mechanism for prevention of stormwater run-on into the activity area. This can be a curb, dike or berm (see BMP S.7 in this chapter for more information) or similar effective means to prevent run-on. In this manner, only the precipitation that falls within the activity area is discharged and/or treated along with the activity process water. The designated area should be paved and sloped to a central collection drain. The collection drain must connect to the sanitary sewer (with pretreatment if required), the on-site holding tank, or the on-site treatment facility, whichever method is selected.

This process water BMP can be made more effective if the activity is covered, thus reducing the total amount of water to be treated.

#### **BMP S.4 COVER THE ACTIVITY WITH A ROOF OR AWNING**

Not every activity can or needs to be located inside a building. In many cases, a simple roof or awning will protect the activity from coming into contact with stormwater, and usually at a lower cost than a complete building. If you do decide to build one of these structures, you will need to obtain permits from the Tacoma Building and Land Use Services Division at 591-5030. They will also be able to help you with fire code requirements and zoning code provisions.

The roof structure can be designed in several ways. One option is a lean-to type of structure, where sheets of corrugated steel, fiberglass, aluminum or similar impermeable material are attached to the wall of a building and are supported by sturdy poles. Similarly, if there is no building to attach to, roofing materials can be sufficiently supported at all four corners as a stand alone cap, or a waterproof tent canopy can be used.

The area of the roof cover should be sufficient to prevent any precipitation from reaching the covered materials. Examples of these types of structures are shown in Figure 5.1.

Another option for covering an activity is to use an overhanging awning of sufficient size to prevent rain from reaching the materials. Many of the building permit, fire code and zoning requirements will also apply to these structures. An example of an awning cover is shown in Figure 5.2.

Activities such as fueling operations may be more conveniently covered by an island-type overhanging roof. This type of roof is supported by columns along the center of the structure rather than at the corners, enabling vehicles easy access underneath while still providing sufficient protection from rain. An example of this type of roof structure is shown in Figure 5.2.

Note that floating fuel stations (such as some used for refueling boats) cannot be covered, according to the fire code.

The particular roof cover option used at a given site is subject to the site layout and available space, affordability, and limitations imposed by other regulations. Structural cover options other than those given above can be used if they perform the same function. This BMP should usually be implemented in conjunction with sump or sanitary sewer drains and provisions for prevention of stormwater run-on into the covered area. BMPs S.6 and S.7 in this chapter present information on sump installation and run-on prevention.

## **BMP S.5      COVER THE ACTIVITY WITH AN ANCHORED TARP OR PLASTIC SHEET**

Some activities, such as stockpiling of raw materials, can be effectively covered with a sturdy tarp or heavy plastic sheet made of impermeable material. Weights such as bricks, tires, or sandbags should be used to anchor the cover in place. Care should be taken to ensure that the tarp or sheet covers the activity completely and that stormwater run-on does not penetrate significantly under the cover. If several sheets are used to form a cover, the sheets should be tethered together or laid in an overlapping manner. If necessary, pins or stakes should be used to anchor the tarp to the ground. The tarp must be inspected daily to ensure that no holes or gaps are present in the tarp coverage. An example of this type of cover is shown in Figure 5.3.

The tarp covering will be easier to keep in place and will last longer if some form of wind protection is possible. Attempts should be made to locate stockpiles adjacent to buildings where winds are reduced, but not in between buildings where a wind tunnel effect can occur

Tarps are an inexpensive and cost effective BMP for many activities. This BMP can be combined with runoff containment/run-on prevention curbs, dikes, and berms for better effectiveness (see BMP S.7 for more information).

## **BMP S.6      PAVE THE ACTIVITY AREA AND SLOPE TO A SUMP OR HOLDING TANK**

This BMP applies to several activities that cannot be covered effectively. It is particularly suited to activities with the potential for leaks and spills, but that otherwise do not generate excessive amounts of polluted runoff. Examples are storage of liquid chemicals, waste oils, and solvents in portable containers such as drums; loading and unloading of liquids from trucks; and painting, finishing and coating activities. A sump or holding tank serves to provide spill containment until the liquids can be pumped out and properly disposed. If the activity produces large amounts of runoff, this BMP will not be very effective because the stray contaminants will overflow the sump or pass through the sump before collection and disposal are possible. To prevent run-on, the area should be enclosed with a berm, curb, or dike as shown in Figure 5.5, Containment Types. The following implementation information is intended for situations where this BMP can be effective.

A designated activity area should be paved and sloped to drain to a central collection point. A sump, vault, or holding tank should be installed underneath this collection drain. Some materials, such as gasoline, can react with asphalt pavement and break it down, releasing additional pollutants. If the area is not yet paved and materials are present which may react with asphalt, the area must be paved with concrete. If the area is already paved with asphalt, an asphalt sealant can be applied which can aid in preventing pavement degradation. Whichever paving material is used, the paved surface must be free of gaps and cracks.

The sump or holding tank should have a capacity large enough to contain the entire volume of a potential spill. An example of a paved activity area with a sump drain is shown in Figure 5.4.

Wash pads may frequently need to use a sump arrangement like this. To keep disposal costs down, a drain cover, plug or shutoff valve upstream of the sump should be used at times when the activity is not occurring.

The cost of constructing a sump and the disposal of accumulated contents can be high, so businesses should consider whether other allowable alternative BMPs can be used.

Commercial services that pump sumps and holding tanks are listed in the Yellow Pages of the phone directory under Environmental and Ecological Services.

BMPs S.4, S.5 and S.7 in this chapter present information on covering activities and run-on prevention.

## **BMP S.7      SURROUND THE ACTIVITY AREA WITH A CURB, BERM, OR DIKE, OR ELEVATE THE ACTIVITY**

This set of BMP options can be an effective means for prevention of stormwater run-on to an activity area. In addition, a curb, berm or dike can be used for containment of spills in the activity area, or for containment of contaminated activity runoff. Generally, a containment BMP is most applicable to spill control situations; that is, sites where runoff is relatively clean, but occasional spills may occur. This BMP may be less expensive to implement than paving the activity area and providing proper drainage collection, but can also be more difficult to maintain if stormwater ponding occurs inside a containment dike.

If a curb, dike or berm is used to prevent stormwater run-on to a covered activity area, and the activity area is paved or otherwise impermeable, the berm should be placed underneath the covering so that rain will not pond inside it. Stormwater run-on can also be prevented by elevating the activity with a platform or other type of pedestal.

Containment may be achieved with concrete curbing, an earthen berm, a tub such as a plastic wading pool, or some other dike material, depending on the activity, its size, and resources available. Activities that require more space and therefore cannot be contained with a tub may need to be surrounded by a curb, dike, or berm. Aboveground storage tanks of liquids, storage of chemicals or wastes in numerous drums, and stockpiling of fertilizer are examples of activities that can be contained effectively in this manner. As the activity area gets larger, containment with an earthen berm can probably be provided less expensively than concrete curbing.

If a curb, berm or dike is used for runoff containment, and other containment sizing regulations (such as fire codes, Department of Ecology or Tacoma-Pierce County Health Department restrictions) do not apply, it should function so that all stormwater runoff from rain events up to the 6 month storm is contained in the immediate activity area until it infiltrates into the ground or is properly disposed of later. This approach is applicable for activities that involve liquid material storage, and that may consequently incur spills. It is also applicable to stockpile areas where runoff is typically polluted with suspended solids. If a stormwater treatment system is presently on-site, a valve should be installed in the containment dike so that excess stormwater can be drained out of the activity area and directed to the treatment system. This valve should always be kept closed unless excess stormwater is being discharged, so that any spills that occur within the activity area can be effectively contained.

Difficulties in maintenance may arise with disposal of the captured water on sites without stormwater treatment capability. The collected rainwater may need to be treated before discharge. If the activity is located on impermeable ground, then potentially contaminated water will accumulate within the containment area. If contaminated, this accumulated water cannot simply be drained from the area; it must be collected and disposed of at a licensed disposal facility. During the wet season, this course of action can lead to frequent draining that may prove costly. In addition, some type of monitoring would be needed to determine if ponded water is contaminated. Depending on the monitoring requirements, this can also be very costly.

For storage of small items, the simplest containment device is a tub or wading pool. A plastic child's wading pool may be sufficient for some activities that do not require a lot of space, such as storing painting materials, and temporary storage of wastes in drums. Make sure the material you are using does not react with the plastic. An example of this is shown in Figure 5.5.



For larger areas, a containment curb, dike, or berm may be necessary. If an earthen berm is used, it must be seeded with grass or other vegetation so that it does not erode. Sketches of a containment dike and a containment curb are shown in Figure 5.5.

The volume of the containment area should be equal to 110% of the volume of the largest tank.

It should be noted that neglect and poor maintenance can render the containment useless. Other BMPs should be considered before containment is. Commercial products are available that are a combination containment box/elevated pedestal. These effective devices prevent stormwater run-on by elevating containers off the ground, and allow for collection of spills and drips inside the pedestal box. Similar arrangements can be constructed by hand as well.

BMPs S.4, S.5 and S.6 in this chapter provide information on covering activities and sump installation.

## **BMP S.8      IMPLEMENT INTEGRATED PEST MANAGEMENT MEASURES**

Use of herbicides, fungicides, and rodenticides should always be done with extreme caution, not only because of the potential harm to humans and pets, but also because of the potential harm to fish, wildlife, and our water resources. In light of the toxic nature of these compounds, special attention should be given to pesticide usage in all applications. The discussion below applies more to large-scale pesticide users, but should be considered for backyard applications as well.

Commercial, agricultural, municipal, and other large scale pesticide users, such as golf courses and parks, should adhere to the principles of integrated pest management (IPM), a decision-making process for pest management that strives for intelligent, environmentally sound control of pests. It is a systems approach to pest management that combines agronomic, biological, chemical and genetic information for educated decisions on the type of control to use, the timing and extent of chemical application, and whether non-chemical means can attain an acceptable level of pest control.

IPM is a preventive measure aimed at knowing the exact pests being targeted for control, the locations and times when pests will pose problems, the level of pest-induced damage that can be tolerated without taking action, the most vulnerable life stage, and control actions that are least damaging to the environment. The major components of IPM are as follows:

- Monitoring and inventory of pest populations
- Determination of pest-induced injury and action levels
- Identification of priority pest problems
- Selection and timing of least toxic management tools
- Site-specific treatment with minimized chemical use
- Evaluation and adjustment of pesticide applications

Monitoring of pest populations is a key to successful IPM implementation. Pest problems are universally easier to control if the problem can be discovered early. With IPM, pesticides are used only as a last resort. Maximization of natural controls, including biological controls and removal of pests by hand, is always the first choice.

More information on IPM is available from the Washington State Department of Agriculture and from the Washington State University Extension Service, or in Appendix IV-B of this volume.

## **BMP S.9      CLEANING CATCH BASINS**

Cleaning catch basins regularly is one of the most important stormwater source control measures that a business can take.

Catch basins are typically located under low spots in parking lots, along curbs and road edges, and where storm drain pipes combine flows. Catch basins on the surface collect runoff for storm drains that are typically located directly underneath them. Most catch basins have some storage in the bottom that never drains to an outflow pipe. This permanent storage area is intended to trap sediments, debris, and other particles that can settle out of stormwater, thus preventing clogging of downstream pipes and washing of these solids into receiving waters.

For additional information on the maintenance of catch basins, refer to Volume V, Runoff Treatment BMPs, Section 4.6, number 5.

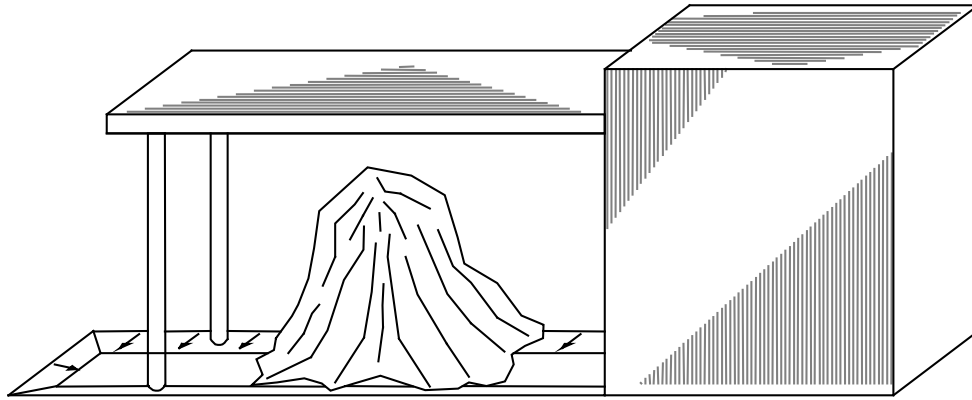
Several companies offer catch basin cleaning services. Pertinent equipment dealers and cleaning services can be found in the telephone Yellow Pages under headings like "Sewer Cleaning Equipment and Supplies" and "Sewer Contractors". All of the solids and stagnant water collected from catch basin sumps must be disposed of properly. None of the sump contents can be flushed into the catch basin outflow pipe. Depending on the nature of the pollutants in the sump, and the associated types of activities taking place on the site, the sump contents may need to be disposed of as hazardous waste. Contractors who perform catch basin cleanout services will be required to follow specified disposal requirements.

It should be apparent that use of other BMPs, such as frequent sweeping of activity areas, covering activity areas, reducing activity occurrence and containing runoff from activity areas will help reduce catch basin cleaning frequency, thus saving time and money. All businesses and agencies should set up maintenance schedules for all of their BMPs so that coordinated BMP maintenance efforts result in reduced catch basin cleaning frequencies.

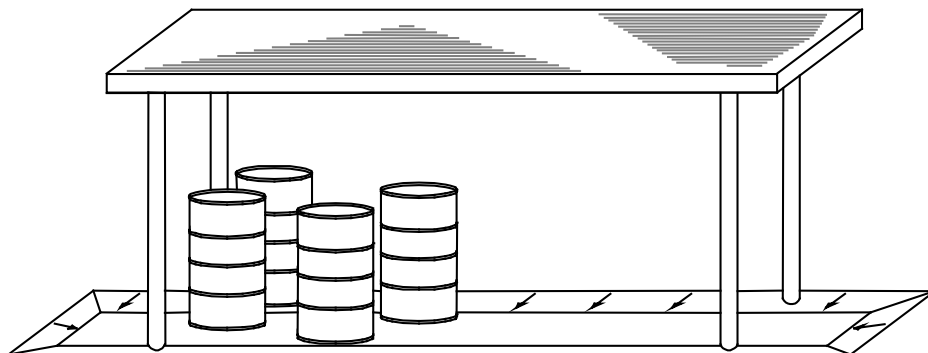
### **5.3 Treatment BMPs**

The previous section gave you source control BMPs -- in other words, how to prevent stormwater from becoming contaminated in the first place. Information on stormwater treatment BMPs can be found in Volume 1, Section 1.4 and Volume 5, particularly Chapter 2.

**FIGURE 5.1**  
**Roofs & Awnings**

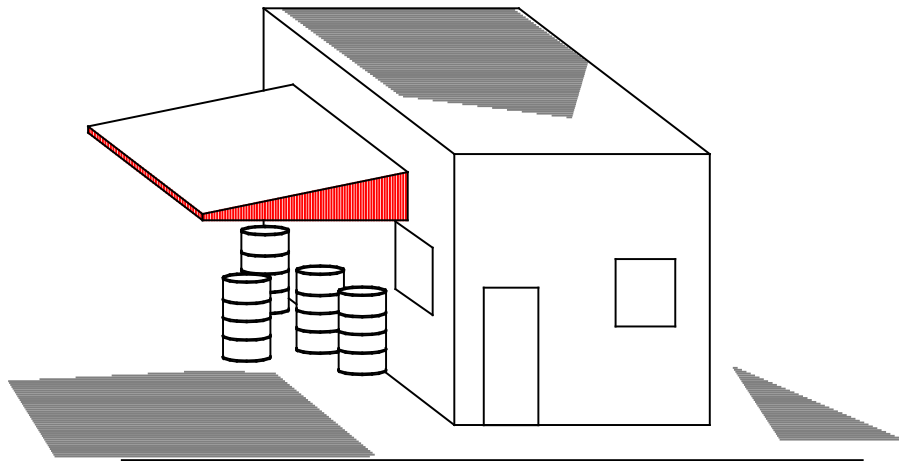


LEAN-TO STRUCTURE  
N.T.S.

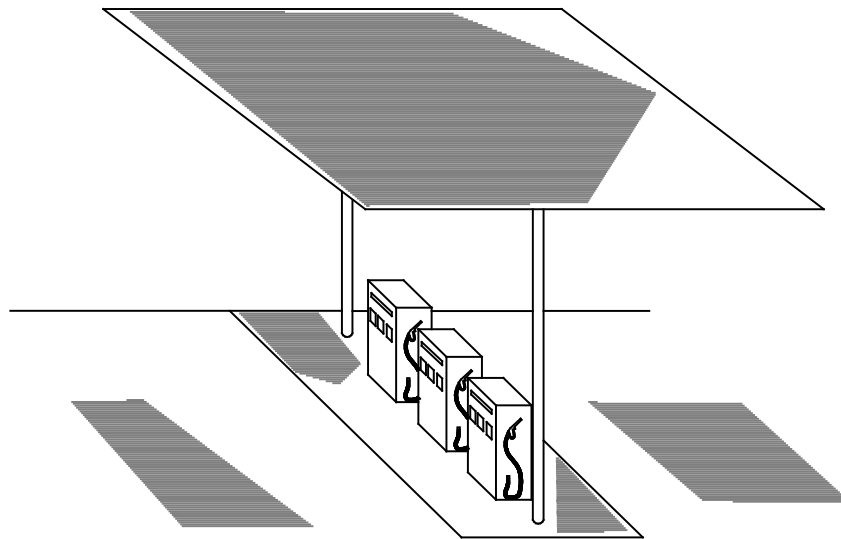


STAND-ALONE CANOPY  
N.T.S.

**FIGURE 5.2**  
**Roofs & Awnings**

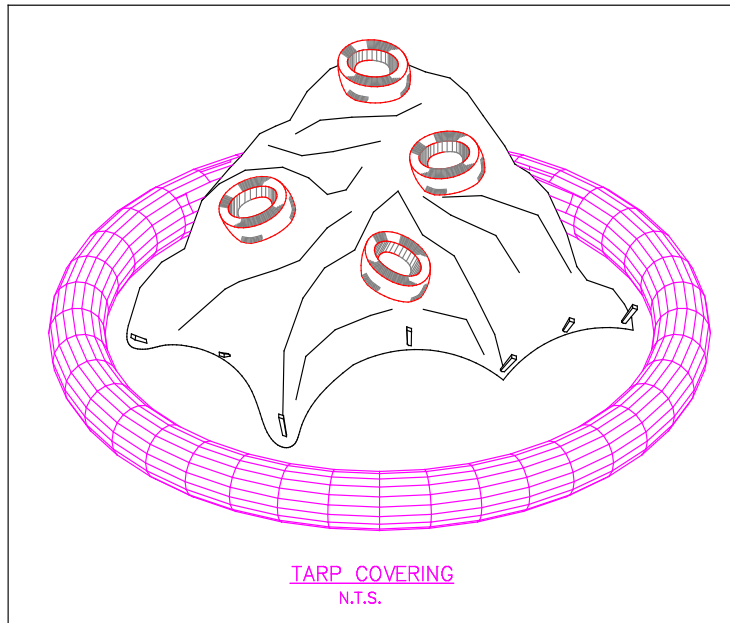


OVERHANGING AWNING  
N.T.S.

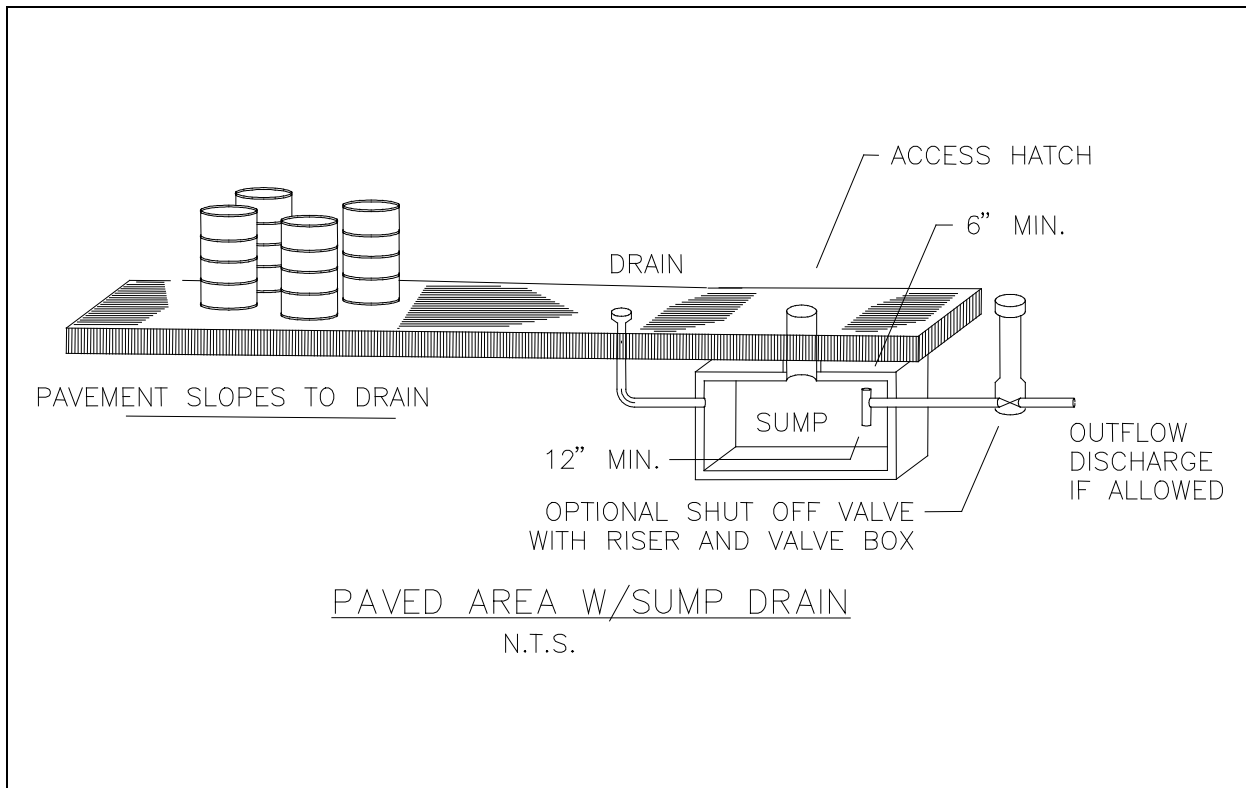


ISLAND-TYPE OVERHANGING ROOF  
N.T.S.

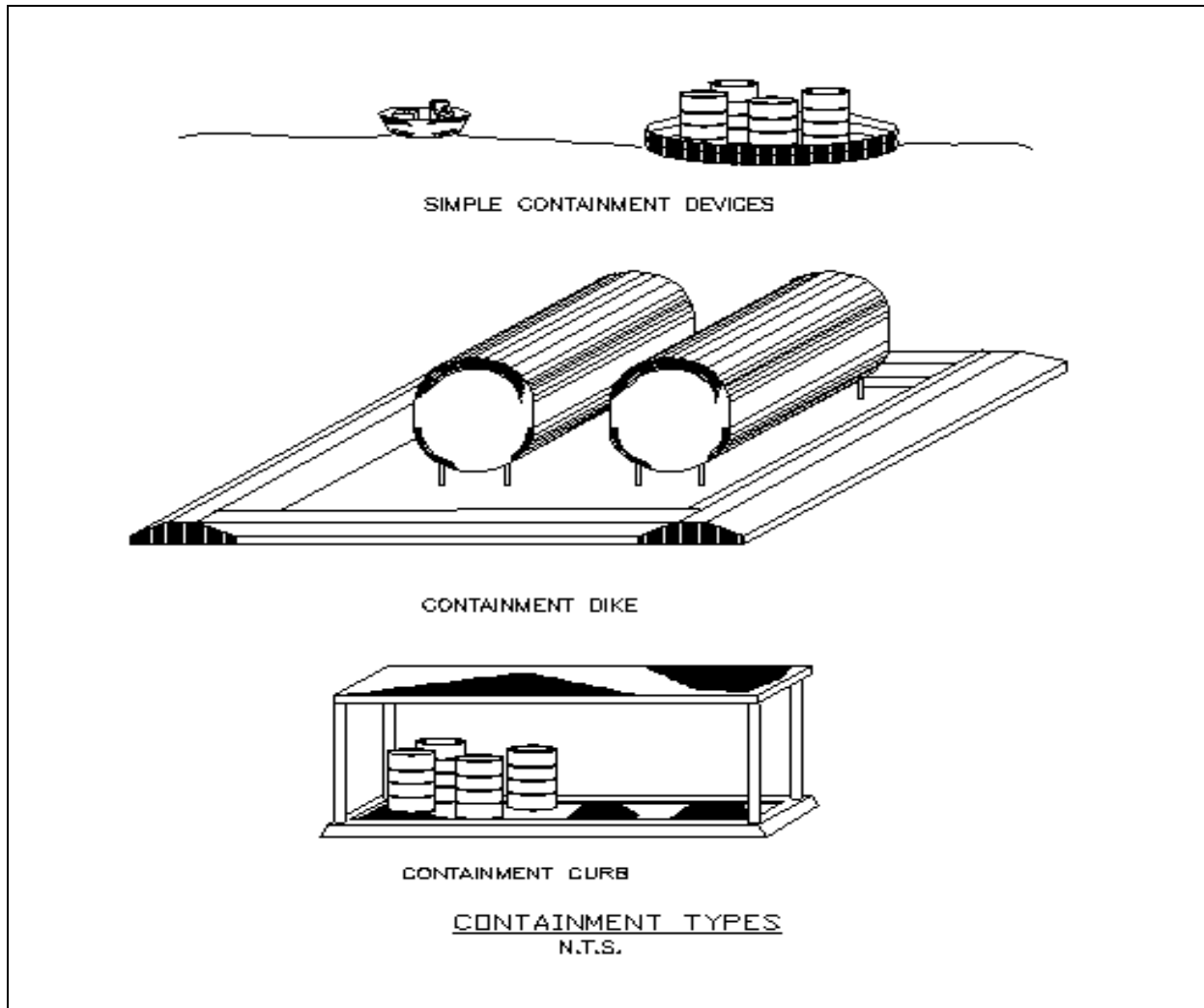
**FIGURE 5.3  
Tarp Covering**



**FIGURE 5.4  
Paved Area with Sump Drain**



**FIGURE 5.5**  
**Containment Types**





## Appendix IV-A

### Recycling/Disposal of Vehicle Fluids/Other Wastes\*

	RECOMMENDED MANAGEMENT
<b>Antifreeze</b>	Store separately for resale. Separate ethylene glycol from propylene glycol for off-site recycling. If not recyclable, send to Treatment, Storage, and Disposal Facility (TSDF) for disposal.
<b>Batteries</b>	INTACT: Accumulate under cover prior to sale, deliver to recycler or, return to manufacturer. BROKEN: Accumulate acid from broken batteries in resistant containers with secondary containment. Send to TSDF for disposal.
<b>Brake fluid</b>	Accumulate in separate, marked, closed container. Do not mix with waste oil. Recycle.
<b>Fuel</b>	Store gasoline, and diesel separately for use or resale. Mixtures of diesel, gasoline, oil, and other fluids may not be recyclable and may require expensive disposal.
<b>Fuel filters</b>	Drain fluids for use as product. With approval of local landfill operator, dispose to dumpster, if needed.
<b>Oil filters</b>	Puncture the filter dome and drain it for 24 hours. Put oil drained from filters into your "USED OIL ONLY" container. Keep drained filters in a separate container marked "USED OIL FILTERS ONLY." Locate a scrap metal dealer who will pick up and recycle your filters. With approval of local landfill operator, dispose of drained filters to dumpster.
<b>Paint</b>	Accumulate oil-based and water-based paints separately for use or resale. If not recyclable, send accumulations to TSDF for disposal.
<b>Power steering fluid</b>	Same as for used oils
<b>Shop towels/oily rags</b>	Use cloth towels that can be laundered and reused. Accumulate used shop towels in a closed container. Sign up with an industrial laundry service that can recycle your towels.
<b>Solvents</b>	Consider using less hazardous solvents or switching to a spray cabinet that doesn't use solvent. Accumulate solvents separately. Consider purchasing your own solvent still and recycling solvent on site. Do not mix with used oil. Do not evaporate as a means of disposal.
<b>Transmission oil, differential and rear end fluids</b>	Accumulate in your "USED OIL ONLY" container. Arrange for pickup for off-site recycling.
<b>Used oils; including, crankcase oil, transmission oil, power steering fluid and differential/rear end oil</b>	Keep used oil in a separate container marked "USED OIL ONLY." Do not mix with brake fluid, or used antifreeze. Do not mix with any other waste if you plan to burn it in your shop for heating. Arrange for pickup for off-site recycling.
<b>Windshield washer fluid</b>	Accumulate separately for use or resale. Discharge to on-site sewage disposal, or, if acceptable by the local sewer authority, discharge to sanitary sewer.

\* This information was obtained from Ecology's Hazardous Waste Program.

For a copy of "Hazardous Waste Services Directory," Publication #91-12s, Revised December 1994, listing facilities which recycle/dispose of wastes, solvents, paints, photographic wastes, refrigerants, oils, oil filters, and silver; provide spill assistance and oil/water separator cleanout service, and drum disposal/recycling; TSD facilities; and waste brokers; call Ecology's Hazardous Waste and Toxic Reduction Program at (360) 407-6721.

# Appendix IV-B

## Example of an Integrated Pest Management Program

---

Integrated Pest Management (IPM) is a natural, long-term, ecologically based systems approach to controlling pest populations. This system uses techniques either to reduce pest populations or maintain them at levels below those causing economic injury, or to so manipulate the populations that they are prevented from causing injury. The goals of IPM are to encourage optimal selective pesticide use (away from prophylactic, broad spectrum use), and to maximize natural controls to minimize the environmental side effects.

A step-by-step comprehensive Integrated Pest Management (IPM) Program is provided below as a guide:

### Introduction

This section provides a sound cultural approach to managing lawns and landscapes and minimizing runoff. Many homeowners or property managers will be able to implement most or all of this approach, others will wish to hire these services out. For the do-it yourselfer, an array of resources are available to assist in the effort. Landscaping businesses, agricultural extensions, local agencies, master gardener programs, local nurseries and even the library can all provide assistance. Landscaping professionals (businesses) are particularly encouraged to practice IPM.

### Definition

“Integrated pest management, or IPM, is an approach to pest control that uses regular monitoring to determine if and when treatments are needed, and employs physical, mechanical, cultural, and biological tactics to keep pest numbers low enough to prevent intolerable damage or annoyance. Least-toxic chemical controls are used as a last resort.”

True IPM is a powerful approach that anticipates and prevents most problems through proper cultural practices and careful observation. Knowledge of the life cycles of the host plants and both beneficial and pest organisms is also important. The IPM section of this study guide is adapted from Least Toxic Pest Management for Lawns by Sheila Daar. Following the IPM process gives you the information you need to minimize damage by weeds, diseases and pests and to treat those problems with the least toxic approaches.

### The Integrated Pest Management Process

#### **Step One: Correctly identify problem pests and understand their life cycle.**

Learn more about the pest. Observe it and pay attention to any damage that may be occurring. Learn about the life cycle. Many pests are only a problem during certain seasons, or can only be treated effectively in certain phases of the life cycle.

#### **Step Two: Establish tolerance thresholds for pests.**

Every landscape has a population of some pest insects, weeds, and diseases. This is good because it supports a population of beneficial species that keep pest numbers in check.

Beneficial organisms may compete with, eat, or parasitize disease or pest organisms. Decide on the level of infestation that must be exceeded before treatment needs to be considered. Pest populations under this threshold should be monitored but don't need treatment. For instance, European crane flies usually don't do serious damage to a lawn unless there are between 25-40 larvae per square foot feeding on the turf in February (in normal weather years). Also, most people consider a lawn healthy and well maintained even with up to 20% weed cover, so treatment, other than continuing good maintenance practices, is generally unnecessary.

### **Step Three: Monitor to detect and prevent pest problems.**

Regular monitoring is a key practice to anticipate and prevent major pest outbreaks. It begins with a visual evaluation of the lawn or landscape's condition. Take a few minutes before mowing to walk around and look for problems. Keep a notebook, record when and where a problem occurs, then monitor for it at about the same time in future years. Specific monitoring techniques can be used in the appropriate season for some potential problem pests, such as European crane fly.

### **Step Four: Modify the maintenance program to promote healthy plants and discourage pests.**

A healthy landscape is resistant to most pest problems. Lawn aeration and overseeding along with proper mowing height, fertilization, and irrigation will help the grass out-compete weeds. Correcting drainage problems and letting soil dry out between waterings in the summer may reduce the number of crane-fly larvae that survive.

### **Step Five: If pests exceed the tolerance thresholds**

Use cultural, physical, mechanical or biological controls first. If those prove insufficient, use the chemical controls described below that have the least non-target impact. When a pest outbreak strikes (or monitoring shows one is imminent), implement IPM then consider control options that are the least toxic, or have the least non-target impact. Here are two examples of an IPM approach:

1. **Red thread disease** is most likely under low nitrogen fertility conditions and most severe during slow growth conditions. Mow and bag the clippings to remove diseased blades. Fertilize lightly to help the grass recover, then begin grasscycling and change to fall fertilization with a slow-release or natural-organic fertilizer to provide an even supply of nutrients. Chemical fungicides are not recommended because red thread cannot kill the lawn.
2. **Crane fly damage** is most prevalent on lawns that stay wet in the winter and are irrigated in the summer. Correct the winter drainage and/or allow the soil to dry between irrigation cycles; larvae are susceptible to drying out so these changes can reduce their numbers. It may also be possible to reduce crane fly larvae numbers by using a power de-thatcher on a cool, cloudy day when feeding is occurring close to the surface. Studies are being conducted using beneficial nematodes that parasitize the crane fly larvae; this type of treatment may eventually be a reasonable alternative.

Only after trying suitable non-chemical control methods, or determining that the pest outbreak is causing too much serious damage, should chemical controls be considered. Study to determine

what products are available and choose a product that is the least toxic and has the least non-target impact. Refer to the Operational BMPs for the use of Pesticides below for guidelines on choosing, storing and using lawn and garden chemicals.

**Step Six: Evaluate and record the effectiveness of the control, and modify maintenance practices to support lawn or landscape recovery and prevent recurrence.**

Keep records! Note when, where, and what symptoms occurred, or when monitoring revealed a potential pest problem. Note what controls were applied and when, and the effectiveness of the control. Monitor next year for the same problems. Review your landscape maintenance and cultural practices to see if they can be modified to prevent or reduce the problem.

A comprehensive IPM Program should also include the proper use of pesticides as a last resort, and vegetation/fertilizer management to eliminate or minimize the contamination of stormwater.

# Appendix IV-C

## Recommendations for Management of Street Wastes

---

### Introduction

This appendix is a summary, taken from the June 1999 draft Ecology publication titled Recommendations for Management of Street Waste (Publication WQ 99-09). The guidance document addresses waste generated from stormwater maintenance activities such as street sweeping and the cleaning of catch basins, and to a limited extent, other stormwater conveyance and treatment facilities. Limited information is available on the characteristics of wastes from detention/retention ponds, bioswales, and similar stormwater treatment facilities. The recommendations provided here may be generally applicable to these facilities, with extra diligence given to waste characterization.

These recommendations do not constitute rules or regulations, but are suggestions for street waste handling, reuse, and disposal using current regulations and the present state of knowledge of street waste constituents. The recommendations are intended to address the liquid and solid wastes collected during routine maintenance of stormwater catch basins, detention/retention ponds and ditches and similar storm water treatment and conveyance structures, and street and parking lot sweeping. In addition to these recommendations, end users and other authorities may have their own requirements for street waste reuse and handling.

**"Street Wastes"** include liquid and solid wastes collected during maintenance of stormwater catch basins, detention/retention ponds and ditches and similar storm water treatment and conveyance structures, and solid wastes collected during street and parking lot sweeping.

**"Street Wastes," as defined here, does not include** solids and liquids from street washing using detergents, cleaning of electrical vaults, vehicle wash sediment traps, restaurant grease traps, industrial process waste, sanitary sewage, mixed process, or combined sewage/stormwater wastes. Wastes from oil/water separators at sites that load fuel are not included as street waste. Street waste also does not include flood debris, land slide debris, and chip seal gravel.

**Street waste does not ordinarily classify as dangerous waste.** The owner of the storm water facility and/or collector of street waste is considered the waste generator and is responsible for determining whether or not the waste designates as dangerous waste. Sampling to date has shown that material from routine maintenance of streets and stormwater facilities does not classify as dangerous waste (See Table D.6 below). However, it is possible that street waste from spill sites could classify as dangerous waste. Street waste from areas with exceptionally high average daily traffic counts may contain contaminants - such as heavy metals, total petroleum hydrocarbons (TPH), and carcinogenic polycyclic aromatic hydrocarbons (c-PAH) - at levels that limit reuse options.

### Street Waste Solids

**Street waste is solid waste.** While street waste from normal street and highway maintenance is not dangerous waste, it is solid waste, as defined under The Solid Waste Management Act (Chapter 70.95 RCW) and under Minimum Functional Standards for Solid Waste Handling (Chapter 173-304 WAC). Under the Solid Waste Management Act, local health departments have primary jurisdiction over solid waste management. Street waste solids may contain

contaminants at levels too high to allow unrestricted reuse. At the time this document is being prepared, the Minimum Functional Standards are being revised. Chapter 173-304 WAC will be replaced with Chapter 173-350 WAC. There are currently no specific references in the Minimum Functional Standards to facilities managing street waste solids. These facilities will typically fit under the section dealing with Piles Used for Storage and Treatment (Section 320 of the proposed revisions). There are no specific references for reuse and disposal options for street wastes in the Minimum Functional Standards, although the Minimum Functional Standards do not apply to clean soils. In the proposed rule, clean soils are defined as 'soils that do not contain contaminants at concentrations which could degrade the quality of air, waters of the state, soils, or sediments; or pose a threat to the health of humans or other living organisms' (WAC 173-350-100). Whether or not a soil is a clean soil depends primarily upon the level of contaminants and, to a lesser degree, on the background level of contaminants at a particular location and the exposure potential to humans or other living organisms. Therefore, both the soil and potential land application sites must be evaluated to determine if a soil is a clean soil. Local health departments should be contacted to determine if a street waste meets the definition of "clean soil" when it will be reused as a soil.

There is no simple regulatory mechanism available to classify street waste solids as "clean" for uncontrolled reuse or disposal. Local health districts have historically used the Model Toxics Control Act Cleanup Regulation (MTCA) Method A residential soil cleanup levels to approximate "clean" and to make decisions on land application proposals. These regulations were amended in February 2001. The MTCA regulation is not intended to be directly applied to setting contaminant concentration levels for land application proposals. However, they may provide human health and environmental threat information and a useful framework for such decisions, when used in conjunction with other health and environmental considerations. The local health department should be contacted to determine local requirements for making this determination.

Using the old MTCA regulations, many local health departments have set a criteria of 200 mg/Kg Total Petroleum Hydrocarbons (TPH) for diesel and heavy fuel oils as a threshold level for clean soil. Using the new MTCA terrestrial ecological evaluation procedures, allowable TPH levels for land application could range from 200 – 460, depending on site characteristics and intended land use. Street waste sampling has historically yielded TPH values higher than 200 mg/kg for hydrocarbons in the diesel and heavy oil range. These values typically reflect interference from natural organic material and, to a lesser extent, relatively immobile petroleum hydrocarbons. The mobile hydrocarbons that are of concern for ground water protection are generally not retained with street waste solids. Ecology's Manchester Lab has developed an analytical method to reduce the problem of natural organic material being included in the TPH analysis for diesel and heavier range hydrocarbons. This new method, called NWTPH-Dx, reduces the background interference associated with vegetative matter by as much as 85% to 95%. However, even with the new methodology, TPH test results for street waste may still be biased by the presence of natural vegetative material and may still exceed 200 mg/kg. . Where the laboratory results report no 'fingerprint' or chromatographic match to known petroleum hydrocarbons, the soils should not be considered to be petroleum contaminated soils.

Street waste solids frequently contain levels of carcinogenic PAHs (c-PAH) that make unrestricted use inappropriate. This is complicated further by analytical interference caused by organic matter that raises practical quantitation or reporting limits. To greatly reduce the level of interference, the use of US EPA Test Method 8270, incorporating the silica gel cleanup step, is recommended. The calculated c-PAH value can vary greatly depending upon how non-detect values are handled. The new MTCA Method A criterion for c-PAH is 0.1 mg/kg (the sum of all

seven c-PAH parameters multiplied by the appropriate toxicity equivalency factor)) for unrestricted land uses. The MTCA criteria for soil cleanup levels for industrial properties is 2.0 mg/kg. Following this guidance, most sites where street wastes could be reused as soil will be commercial or industrial sites, or sites where public exposure will be limited or prevented.

**Permitting of street waste treatment and storage facilities as solid waste handling facilities by the local health department is required.** Under the Solid Waste Management Act, local health departments have primary jurisdiction over solid waste management

Street waste handling facilities are subject to the requirements of the Minimal Functional Standards for Solid Waste Handling. The specific requirements will depend upon the manner in which the waste is managed. Most facilities will probably be permitted under the section dealing with Piles Used for Storage and Treatment (Section 320 of the proposed revisions)

For most facilities, permit requirements include a plan of operation, sampling, record keeping and reporting, inspections, and compliance with other state and local requirements. The plan of operation should include a procedure for characterization of the waste and appropriate reuse and disposal options, consistent with the recommendations in this document and applicable federal, state and local requirements.

**A street waste site evaluation (see sample at end of this appendix) is suggested for all street waste as a method to identify spill sites or locations that are more polluted than normal.** The disposal and reuse options listed below are based on characteristics of routine street waste and are not appropriate for more polluted wastes. The collector of street waste should evaluate it both for its potential to be classified as dangerous waste and to not meet end users requirements.

**Street waste that is suspected to be dangerous waste should not be collected with other street waste.** Material in catch basins with obvious contamination (unusual color, staining, corrosion, unusual odors, fumes, and oily sheen) should be left in place or segregated until tested. Testing should be based on probable contaminants. Street waste that is suspected to be dangerous waste should be collected and handled by someone experienced in handling dangerous waste. If potential dangerous waste must be collected because of emergency conditions, or if the waste becomes suspect after it is collected, it should be handled and stored separately until a determination as to proper disposal is made. Street waste treatment and storage facilities should have separate "hot load" storage areas for such waste. **Dangerous Waste** includes street waste known and suspected to be dangerous waste. This waste must be handled following the Dangerous Waste Regulations (Chapter 173-303 WAC) unless testing determines it is not dangerous waste.

**Spills should be handled by trained specialists.** Public works maintenance crews and private operators conducting street sweeping or cleaning catch basins should have written policies and procedures for dealing with spills or suspected spill materials. Emergency Spill Response telephone numbers should be immediately available as part of these operating policies and procedures.

**The end recipient of street waste must be informed of its source and may have additional requirements for its use or testing that are not listed here.** This document is based primarily on average street waste's chemical constituents and their potential affect on human health and the environment. There are physical constituents (for example, broken glass or hypodermic needles) or characteristics (for example, fine grain size) that could also limit reuse options.

Additional treatment such as drying, sorting, or screening may also be required, depending on the needs and requirements of the end user.

**Street waste treatment and storage facilities owned or operated by governmental agencies should be made available to private waste collectors and other governmental agencies on a cost recovery basis.** Proper street waste collection and disposal reduces the amount of waste released to the environment. The operators of street waste facilities should restrict the use of their facilities to certified and/or licensed waste collectors who meet their training and liability requirements.

**The use of street waste solids under this guidance should not lead to designation as a hazardous waste site, requiring cleanup under MTCA.** Exceeding MTCA Method A unrestricted land use cleanup levels in street waste and products made from street waste, does not automatically make the site where street waste is reused a cleanup site. A site is reportable only if "-a release poses a threat to human health or the environment-" (Model Toxic Control Act). The reuse options proposed below are designed to meet the condition of not posing a threat to human health or the environment.

**Testing of street waste solids will generally be required as part of a plan of operation that includes procedures for characterization of the waste.** Testing frequency, numbers of samples, parameters to be analyzed, and contaminant limit criteria should all be provided as part of an approved plan of operation. Tables D.4 and D.5 below provide some recommended parameters and sampling frequencies for piles of street waste solids from routine street maintenance. These are provided as guidance only, and are intended to assist the utility and the local health department in determining appropriate requirements. Sampling requirements may be modified, over time, based on accumulated data. When the material is from a street waste facility or an area that has never been characterized by testing, the test should be conducted on a representative sample before co-mingling with other material. Testing in these instances would be to demonstrate that the waste does not designate as dangerous waste and to characterize the waste for reuse. At a minimum, the parameters in Table D.4 are recommended for these cases. Note that it will generally not be necessary to conduct TCLP analyses when the observed values do not exceed the recommended values in Table D.4. Table D.6 illustrates some observed relationships between total metals and TCLP metals values.

For further information on testing methods and sampling plans, refer to:

- SW 846 (US EPA, Office of Solid Waste, Test Methods for Evaluating Solid Wastes, 3rd Ed.) and
- Standard Methods for the Examination of Water and Wastewater (American Public Health Association, et al., 18th Edition 1992)

**For street waste not exceeding the suggested maximum values in Table D.4, the following street waste solids reuse and disposal options are recommended:**

- Street sweepings that consist primarily of leaves, pine needles and branches, and grass cuttings from mowing grassy swales can be composted. Litter and other foreign material must be removed prior to composting or the composting facility must provide for such removal as part of the process. The screened trash is solid waste and must be disposed of at an appropriate solid waste handling facility.



- Coarse sand screened from street sweeping after recent road sanding, may be reused for street sanding, providing there is no obvious contamination from spills. The screened trash is solid waste and must be disposed of at an appropriate solid waste handling facility.
- Roadside ditch cleanings, not contaminated by a spill or other release and not associated with a stormwater treatment system such as a bioswale, may be screened to remove litter and separated into soil and vegetative matter (leaves, grass, needles, branches, etc.). The soils from these activities are not generally regulated as solid waste. Ditching material that may be contaminated must be stored, tested and handled in the same manner as other street waste solids. It is the generator's responsibility to visually inspect and otherwise determine whether the materials may be contaminated.
- Construction street wastes - solids collected from sweeping or in storm water treatment systems at active construction sites - may be placed back onto the site that generated it, or managed by one of the methods listed below, provided that it has not been contaminated as a result of a spill. For concrete handling at construction site, refer to BMP C151 in Volume II, Construction Stormwater Pollution Prevention.
- Screened street waste soils may be used as feedstock materials for topsoil operations. This option should be reserved for street waste soils with very low levels of contaminants. Diluting street waste soils with clean soils or composted material must not be used as a substitute for treatment or disposal. There may be physical contaminants (for example, glass, metal, nails, etc.) in street waste that cannot be entirely screened from the waste. Where present, these contaminants in street waste could preclude its use as feedstock material for topsoil operations.
- Fill in parks, play fields, golf courses and other recreational settings, where direct exposure by the public is limited or prevented. One way to accomplish is to cover the fill with sod, grass or other capping material to reduce the risk of soil being ingested. The level of contaminants in the street waste must be evaluated to ensure that the soils meet the definition of clean soils when used in this manner.
- Fill in commercial and industrial areas, including soil or top dressing for use at industrial sites, roadway medians, airport infields and similar sites, where there is limited direct human contact with the soil, and the soils will be stabilized with vegetation or other means. The level of contaminants in the street waste must be evaluated to ensure that the soils meet the definition of clean soils when used in this manner.
- Top dressing on roadway slopes, road or parking lot construction material and road subgrade, parking lot subgrade, or other road fill. The level of contaminants in the street waste must be evaluated to ensure that the soils meet the definition of clean soils when used in this manner.
- Daily cover or fill in a permitted municipal solid waste landfill, provided the street waste solids have been dewatered. Street waste solids may be acceptable as final cover during a landfill closure. The local health department and landfill operator should be consulted to determine conditions of acceptance.
- Treatment at a permitted contaminated soil treatment facility.
- Recycling through incorporation into a manufactured product, such as Portland cement, prefab concrete, or asphalt. The facility operator should be consulted to determine conditions of acceptance.
- Other end-use as approved by the local health department

- Disposal at an appropriate solid waste handling facility.

**For street waste that exceed the suggested maximum values in Table D.4, the following street waste solids reuse and disposal options are recommended:**

- Treatment at a permitted contaminated soil treatment facility.
- Recycling through incorporation into a manufactured product, such as Portland cement, prefab concrete, or asphalt. The facility operator should be consulted to determine conditions of acceptance.
- Other end-use as approved by the local health department
- Disposal at an appropriate solid waste handling facility.

## **Street Waste Liquids**

**Street waste collection should emphasize solids in preference to liquids.** Street waste solids are the principal objective in street waste collection and are substantially easier to store and treat than liquids.

**Street waste liquids require treatment and/or must follow location limitations before their discharge.** Street waste liquids usually contain high amounts of suspended and total solids and adsorbed metals. Treatment requirements depend on the discharge location.

**Discharges to sanitary sewer and storm sewer systems must be approved by the entity responsible for operation and maintenance of the system.** Ecology will not generally require waste discharge permits for discharge of stormwater decant to sanitary sewers or to stormwater treatment BMPs constructed and maintained in accordance with Ecology's Stormwater Management Manual for Western Washington. (See Volume 5 for further detail).

**The following disposal options are recommended, in order of preference, for catch basin decant liquid and for water removed from stormwater treatment facilities.**

Under the Municipal General Permit, municipalities are required to use this guidance in determining appropriate means of dealing with street wastes from stormwater maintenance activities. Your regional Department of Ecology water quality staff can help you with treatment standards and permit requirements for your particular situation.

**Discharge of catch basin decant liquids to a municipal sanitary sewer connected to a Public Owned Treatment Works (POTW) is the preferred disposal option.** Discharge to a municipal sanitary sewer requires the approval of the sewer authority. Street waste liquids discharged to a POTW may be treated at a combined street waste liquid and solid facility (decant facility) or at separate liquids only facilities. These liquid only facilities may consist of modified type 2 catch basins (with a flow restrictor or oil/water separator) or water quality vaults, strategically located through the sanitary collection system. These should provide 24-hour detention for the expected volumes and should be constructed and operated to ensure that the decant discharge does not resuspend sediments. Sewer authorities should require periodic sampling and decant facility operators should test their waste effluent on a regular basis, but street waste decant liquid should meet the most restrictive local limits with 24 hours of undisturbed gravity settling. Overnight settling is more practical and will likely meet most local

pretreatment requirements. (See Table D.9 *Catch Basin Decant Values Following Settling* for typical catch basin decant values from King County's decant facility at Renton).

State and local regulations generally prohibit discharge of stormwater runoff into sanitary sewers, to avoid hydraulic overloads and treatment performance problems. The volume of storm water discharged from catch basins and small stormwater treatment facilities is generally not sufficient to be a problem, provided the discharge point is properly selected and designed.

**Stormwater removed from catch basins and stormwater treatment wetvaults may be discharged into a Basic or Enhanced Stormwater Treatment BMP.**

Decant liquid collected from cleaning catch basins and stormwater treatment wetvaults may be discharged back into the storm sewer system under the following conditions:

- The preferred disposal option of discharge to sanitary sewer is not reasonably available, **and**
- The discharge is to a Basic or Enhanced Stormwater Treatment Facility (See Volume V, Chapters 3 and 4), **and**
- The storm sewer system owner/operator has granted approval and has determined that the treatment facility will accommodate the increased loading.

Pretreatment may be required to protect the treatment BMP.

Reasonably available will be determined by the stormwater utility and by the circumstances, including such factors as distance, time of travel, load restrictions, and capacity of the stormwater treatment facility. Some jurisdictions may choose not to allow discharge back to the storm sewer system. Currently King County does not allow such discharges, under King County Code 9.12 – Water Quality.

**Discharge back into the storm sewer is an acceptable option, under certain conditions:**

- Other practical means are not reasonably available, **and**
- Pretreatment is provided by discharging to a modified type 2 catch basin (with a flow restrictor or oil/water separator) or water quality vault, **and**
- The discharge is upstream of a basic or enhanced stormwater treatment BMP, **and**
- The storm sewer system owner/operator has granted approval.

Other practical means includes the use of decanting facilities and field decant sites that discharge to sanitary sewers or discharge to an approved stormwater treatment BMP.

Limited field testing of flocculent aids has been conducted. While the use of flocculent aids is promising, sufficient testing has not been conducted to allow approval of any specific product or process. In general, the following conditions must be met for flocculent use to be approved:

- The flocculent must be non-toxic under circumstances of use and approved for use by the Department of Ecology
- The decant must be discharged to an approved basic or enhanced stormwater treatment BMP, with sufficient capacity and appropriate design to handle the anticipated volume and pollutant loading

- The discharge must be approved by the storm sewer system owner/operator.

**Water removed from stormwater ponds, vaults and oversized catch basins may be returned to storm sewer system.** Stormwater ponds, vaults and oversized catch basins contain substantial amounts of liquid, which hampers the collection of solids and pose problems if the removed waste must be hauled away from the site. Water removed from these facilities may be discharged back into the pond, vault or catch basin provided:

- Clear water removed from a stormwater treatment structure may be discharged directly to a downgradient cell of a treatment pond or into the storm sewer system.
- Turbid water may be discharged back into the structure it was removed from if:
  - The removed water has been stored in a clean container (eductor truck, Baker tank or other appropriate container used specifically for handling stormwater or clean water) and
  - There will be no discharge from the treatment structure for at least 24 hours.
- The discharge must be approved by the storm sewer system owner/operator.

Vegetation management and structural integrity concerns sometimes require that the ponds be refilled as soon after solids removal as possible. For ponds and other systems relying on biological processes for waste treatment, it is often preferable to reuse at least some portion of the removed water.

## Site Evaluation

**A site evaluation is suggested as method to identify spill sites or locations that are more polluted than normal.**

The site evaluation will aid in determining if waste should be handled as dangerous waste and in determining what to test for if dangerous waste is suspected. The site evaluation will also help to determine if the waste does not meet the requirements of the end users.

There are three steps to a site evaluation:

1. An **historical review** of the site for spills, previous contamination and nearby toxic cleanup sites and dangerous waste and materials.

The historical review will be easier if done on an area wide basis prior to scheduling any waste collection. The historical review should be more thorough for operators who never collected waste at a site before. At a minimum, the historical review should include operator knowledge of the area's collection history or records kept from previous waste collections.

Private operators should ask the owner of the site for records of previous contamination and the timing of the most recent cleaning. Ecology's Hazardous Substance Information Office maintains a Toxic Release Inventory and a "Facility Site" web page, tracking more than 15,000 sites. This information is available through the Internet at <http://www.wa.gov/ecology/iss/fsweb/fshome.html> or by calling a toll-free telephone number (800-633-7585). The web page allows anyone with web-access to search for facility information by address, facility name, town, zip code, and SIC code, etc. It lists why the Department of Ecology is tracking each one (NPDES, TSCA, RCRA, Clean Air Act, etc.), as well as who to call within Ecology to find out more about the given facility.

2. An **area visual inspection** for potential contaminant sources such as a past fire, leaking tanks and electrical transformers, and surface stains.

The area around the site should be evaluated for contaminant sources prior to collection of the waste. The area visual inspection may be done either as part of multiple or as single site inspections. If a potential contaminant source is found, the waste collection should be delayed until the potential contaminant is assessed.

A second portion of the area visual inspection is a subjective good housekeeping evaluation of the area. Locations with poor housekeeping commonly cut corners in less obvious places and should be inspected in greater detail for illegal dumping and other contamination spreading practices.

3. **A waste and container inspection** before and during collection.

The inspection of the waste and catch basin or vault is the last and perhaps most critical step in the site evaluation.

For example, if the stormwater facility has an unusual color in or around it, then there is a strong possibility that something could have been dumped into it. Some colors to be particularly wary of are yellow-green from antifreeze dumping and black and/rainbow sheen from oil and/or grease dumping. In addition, if any staining or corrosion is observed, then a solvent may have been dumped.

Fumes are also good indicators of potential dangerous or dangerous waste. Deliberate smelling of catch basins should be avoided for worker safety, but suspicious odors may be encountered from catch basins thought to be safe. Some suspicious odors are rotten eggs (hydrogen sulfide is present), gasoline or diesel fumes, or solvent odors. If unusual odors are noted, contact a dangerous waste inspector before cleaning the basin.

*Finally, operator experience is the best guide to avoid collection of contaminated waste.*

**Table C.1 - Typical TPH Levels in Street Sweeping and Catch Basin Solids**

Reference	Street Sweeping (mg/kg)	Catch Basin Solid (mg/kg)
Snohomish County (1) (Landau 1995)	390 – 4300	
King County (1) (Herrera 1995)		123 – 11049 (Median 1036)
Snohomish County & Selected Cities (1) (W & H Pacific, 1993)	163 - 1500 (Median 760)	163 – 1562 (Median 760)
City of Portland (2) (Bresch)		MDL – 1830 (Median – 208)
Oregon (1) (Collins; ODOT 1998)	1600 – 2380	
Oregon (3) (Collins; ODOT 1998)	98 - 125	

(1) Method WTPH 418.1; does not incorporate new methods to reduce background interference due to vegetative material

(2) Method NWTPH-Dx

(3) Method WTPH – HCID

**Table C.2 - Typical c-PAH Values in Street Waste Solids and Related Materials**

Sample Source Analyte	City of Everett					WSDOT	
	Street Sweepings	Soil	3-Way Topsoil	Vactor Solids	Leaf & Sand	Sweepings – Fresh	Sweepings Weathered
Benzo(a)anthracene	0.1U	0.076U	0.074U	0.21	0.45	0.56	0.40
Chrysene	0.14	0.09	0.074U	0.32	0.53	0.35	0.35
Benzo(b)fluoranthene	0.11	0.076U	0.074U	0.27	0.52	0.43	0.51
Benzo(k)fluoranthene	0.13	0.076U	0.074U	0.25	0.38	0.39	0.40
Benzo(a)pyrene	0.13	0.076U	0.074U	0.26	0.5	0.41	0.33U
Indeno(1,2,3-cd)pyrene	0.1U	0.076U	0.074U	0.19	0.39	NR	NR
Dibenzo(a,h)anthracene	0.1U	0.076U	0.074U	0.081	0.12	0.39	0.33U
Revised MTCA	0.215	0.134	0.134	0.388	0.727	0.708	0.597
Benzo(a)pyrene [ND=PQL]							
Benzo(a)pyrene [ND=1/2 PQL]	0.185	0.069	0.067	0.388	0.727	0.708	0.366
Benzo(a)pyrene [See below]	0.185	0.069	0	0.388	0.727	0.708	0.366
Benzo(a)pyrene [ND=0]	0.155	0.001	0	0.388	0.727	0.708	0.135

\*If the analyte was not detected for any PAH, then ND=0; If analyte was detected in at least 1 PAH, then ND=1/2PQL; If the average concentration (using ND=1/2 PQL) is greater than the maximum detected value, then ND=Maximum value.

The new Method A soil cleanup level for unrestricted land use is 0.1 mg/Kg for BAP. (WAC 173-340-900, Table 740-1)

The new Method A soil cleanup level for industrial properties is 2 mg/Kg for BAP. (WAC 173-340-900, Table 745-1)

**Table C.3 - Typical Metals Concentrations in Catch Basin Sediments**

PARAMETER	Ecology 1993	Thurston 1993	King County 1995	King County 1995
METALS; TOTAL (mg/kg)	(Min – Max)	(Min – Max)	(Min - Max)	Mean
As	<3 -- 24	.39 -- 5.4	4 – 56	0.250
Cd	0.5 -- 2.0	< 0.22 -- 4.9	0.2 – 5.0	0.5
Cr	19 -- 241	5.9 -- 71	13 - 100	25.8
Cu	18 -- 560	25 -- 110	12 - 730	29
Pb	24 -- 194	42 -- 640	4 – 850	80
Ni	33 -- 86	23 -- 51	14 – 41	23
Zn	90 -- 558	97 -- 580	50 – 2000	130
Hg	.04 -- .16	.024 -- .193		

**Table C.4 - Recommended Parameters and Suggested Values for Determining Reuse & Disposal Options**

Parameter	Suggested Maximum Value
Arsenic, Total	20.0 mg/kg (a)
Cadmium, Total	2.0 mg/kg (b)
Chromium, Total	42 mg/kg (c)
Lead, total	250 mg/kg (d)
Nickel	100 mg/kg (e)
Zinc	270 mg/kg (e)
Mercury (Inorganic)	2.0 mg/kg (f)
PAHs (Carcinogenic)	0.1 – 2.0 mg/kg (see Note at (g) below)
TPH (Heavy Fuel Oil)	200 - 460 mg/kg (see Note at (h) below)
TPH (Diesel)	200 – 460 mg/kg (see Note at (h) below)
TPH (Gasoline)	100 mg/kg (i)
Benzene	0.03 mg/kg (i)
Ethylbenzene	6 mg/kg (i)
Toluene	7 mg/kg (i)
Xylenes (Total)	9 mg/kg (i)

(a) Arsenic: from MTCA Method A - Table 740-1: Soil cleanup levels for unrestricted land uses

(b) Cadmium: from MTCA Method A – Table 740-1: Soil cleanup levels for unrestricted land uses s.

(c) Chromium; from MTCA Method A - Table 740-1: Soil cleanup levels for unrestricted land uses

(d) Lead; from MTCA Method A – Table 740-1: Soil cleanup levels for unrestricted land uses

(e) Nickel and Zinc; from MTCA Table 749-2: Protection of Terrestrial Plants and Animals

(f) Mercury; from MTCA Method A – Table 740-1: Soil cleanup levels for unrestricted land uses

(g) PAH-Carcinogenic; from MTCA Method A – Table 740-1: Soil cleanup levels for unrestricted land uses and Table 745-1, industrial properties, based on cancer risk via direct contact with contaminated soil (ingestion of soil) in residential land use situations and commercial/industrial land uses. Note: The local health department may permit higher levels as part of a Plan of Operation, where they determine that the proposed end use poses little risk of direct human contact or ingestion of soil.

(h) TPH: from MTCA Tables 749-2 & 749-3: Protection of Terrestrial Plants and Animals. Values up to 460 mg/kg may be acceptable where the soils are capped or covered to reduce or prevent exposure to terrestrial plants and animals. Where the laboratory results report no 'fingerprint' or chromatographic match to known petroleum hydrocarbons, the soils will not be considered to be petroleum contaminated soils.

(i) BETX; from MTCA Method A - Table 740-1: Soil cleanup levels for unrestricted land uses.

**Table C.5 - Recommended Sampling Frequency for Street Waste Solids**

Cubic Yards of Solids	Minimum Number of Samples
0 – 100	3
101 – 500	5
501 – 1000	7
1001 – 2000	10
>2000	10 + 1 for each additional 500 cubic yards

*Modified from Ecology's Interim Compost Guidelines*

**Table C.6 - Pollutants in Catch Basin Solids – Comparison to Dangerous Waste Criteria**

PARAMETER	Range of Values in Catch Basin Waste	Range of Values in Catch Basin Waste	Dangerous Waste Criteria
METALS	Total Metals (mg/kg)	TCLP Metals (mg/kg)	TCLP values (mg/l)
As	<3 – 56	< .02 - 0.5	5.0
Cd	<.22 – 5	.0002 - .03	1.0
Cr	5.9 - 241	.0025 - .1	5.0
Cu	12 - 730	.002 -- .88	none
Pb	4 - 850	.015 -- 3.8	5.0
Ni	23 - 86	< .01 -- .36	none
Zn	50 - 2000	.04 -- 6.7	none
Hg	.02 - .19	.0001 -- .0002	0.2

*Data from Thurston County (Thurston County 1993), King County (Herrera 1995) and Ecology (Serdar; Ecology 1993).*

**Table C.7 - Typical Catch Basin Decant Values Compared to Surface Water Quality Criteria**

PARAMETER	State Surface Water Quality Criteria		Range of Values Reported	Range of Values Reported
	Freshwater Acute (ug/l – dissolved metals)	Freshwater Chronic (ug/l – dissolved metals)	Total Metals (ug/l)	Dissolved Metals (ug/l)
Arsenic	360	190	100 – 43000	60 - 100
Cadmium*	2.73	0.84	64 - 2400	2 - 5
Chromium (total)			13 -- 90000	3 - 6
Chromium (III)*	435	141		
Chromium (VI)	0.5	10		
Copper*	13.04	8.92	81 -- 200000	3 - 66
Lead*	47.3	1.85	255 -- 230000	1 - 50
Nickel*	1114	124	40 -- 330	20 - 80
Zinc*	90.1	82.3	401 -- 440000	1900 - 61000
Mercury	2.10	.012	0.5 -- 21.9	

\*Hardness dependent; hardness assumed to be 75 mg/l



**Table C.8 - Typical Values for Conventional Pollutants in Catch Basin Decant**

<b>PARAMETER</b>	<b>Ecology 1993</b>	<b>(Min - Max)</b>	<b>King County 1995</b>	<b>(Min - Max)</b>
<b>Values as mg/l; except where stated</b>	<b>Mean</b>		<b>Mean</b>	
PH	6.94	6.18 - 7.98	8	6.18 - 11.25
Conductivity (umhos/cm)	364	184 - 1110	480	129 - 10,100
Hardness (mg/l CaCO3)	234	73 - 762		
Fecal Coliform (MPN/100 ml)	3000			
BOD	151	28 - 1250		
COD	900	120 - 26,900		
Oil & Grease	11	7.0 - 40	471	15 - 6242
TOC	136	49 - 7880	3670	203 - 30,185
Total Solids	1930	586 - 70,400		
Total Dissolved Solids	212	95 - 550		
Total Suspended Solids	2960	265 - 111,000		
Settleable Solids (ml/hr)	27	2 - 234	57	1 - 740
Turbidity (ntu)	1000	55 - 52,000	4673	43 - 78,000

**Table C.9 - Catch Basin Decant Values Following Settling<sup>1</sup>**

<b>Parameter; Total Metals in mg/l</b>	<b>Portland – Inverness Site Min - Max</b>	<b>King County - Renton Min - Max</b>	<b>METRO Pretreatment Discharge Limits</b>
Arsenic	.0027 .015	< MDL – 0.12	4
Cadmium	.0009 - .0150	< MDL – 0.11	0.6
Chromium	.0046 - .0980	.017 – .189	5
Copper	.015 - .8600	.0501 – .408	8
Lead	.050 – 6.60	.152 – 2.83	4
Nickel	.0052 - .10	.056 - .187	5
Silver	.0003 - .010	< MDL	3
Zinc	.130 – 1.90	.152 – 3.10	10
Settleable Solids; ml/L	No Data	.02 - 2	7
Nonpolar FOG	5.7 - 25	5 - 22	100
Ph (std)	6.1 – 7.2	6.74 – 8.26	5.0 - 12.0
TSS	2.8 - 1310		
Recorded Total Monthly Flow; Gallons	Data not available	31,850 - 111,050	
Recorded Max. Daily Flow; Gallons	Data not available	4,500 - 18,600	25,000 GPD
Calculated Average Daily Flow; GPD	Data not available	1517 - 5428	

<sup>1</sup>) Data from King County's Renton Facility (data from 1998 – 1999) and the City of Portland's Inverness Site (data from 1999 – 2001); detention times not provided

## **Resource Materials – Management of Street Wastes**

---

Austin, City of, Removal Efficiencies of Stormwater Control Structures. Environmental and Conservation Services Department, 1990.

City of Portland Vactor Waste Decant Data, Personal Communication with Katie Bretsch, April 2000

Campbell, Robert, Street Waste Characterization Testing Program, VTP-1, Snohomish County Public Works Maintenance & Operations Division, March 1994.

Collins, Jay, Oregon Department of Transportation, Street Waste Issues and Options FHWA-OR-RD-99-05, July 1998

Ecology, Interim TPH Policy, Publication N. ECY 97-600, 1997.

Ecology, Analytical Methods for Petroleum Hydrocarbons, Publication No. ECY 97-602, June 1997.

Ecology, Dangerous Waste Regulations, Chapter 173-303 WAC.

Ecology, Discussion Draft - Recommendations for Management of Street Waste, June 1999

Ecology, Draft Minimum Functional Standards for Solid Waste Handling, Chapter 173-350 WAC, December 1999.

Ecology, Guidance for Remediation of Petroleum Contaminated Soils, pub 91-30, 1994.

Ecology, Minimum Functional Standards for Solid Waste Handling, Chapter 173-304 WAC.

Ecology, Model Toxics Control Act (MTCA) Cleanup Regulations, Chapter 173-340 WAC

Ecology, Water Quality Standards For Surface Waters of the State of Washington, Chapter 173-201A.

Hazardous Waste Management Act of 1976, Chapter 70.105 RCW

Herrera Environmental Consultants, Inc., King County Maintenance Waste Disposal Characterization Study, prepared for King County Surface Water Management Division, January Draft, 1995.

Herrera Environmental Consultants, Inc., Street Truck Operations and Disposal Practices, 1991.

Holz, Thomas, Street Waste Disposal, Thurston County, Washington: Final Engineering Report and One Year Certification, Grant No. Tzx 91-129, May, 1994.

Jacobson, Michael, Data Summary of Catch Basin and Vactor Waste Contamination in Washington State, Final Report, Center for Urban Water Resources, University of Washington, 1993.

King County, Vector Waste Disposal Plan, King County Surface Water Management Division, Water Quality Unit, 1994.

King County's Renton Facility Decant Data, Personal Correspondence with Jerry Creek, and Susan Turner, June 1999

Landau Associates, Inc. Snohomish County Street Waste Characterization, Final Report, December 1995

Pitt, R. and P. Bissonnette, Bellevue Urban Runoff Program; Summary Report, Prepared for City of Bellevue Storm and Surface Water Utility, 1984.

Pitt, R., 1985, Characterizing and Controlling Urban Runoff through Street and Sewer Cleaning, EPA/600/2-85/038

Pond, Rodney, South Base Pond Report - The Response of Wetland Plants to Stormwater Runoff From a Transit Base, Municipality of Metropolitan Seattle Publication 775, 1993.

Schueler, Thomas, R., Pollutant Dynamics of Pond Muck, Wat. Prot. Techniques, 1 (2). Summer 1994

Serdar, Dave, Ecology, Contaminants in Vector Truck Wastes, April 1993

Thurston County Environmental Health Division, (Environmental Health Division-Unpublished data), 1993

Thurston County Environmental Health Division, Report on Street Facility Monitoring Grant Tax No. 91-129, April 1993

TYMCO, Inc. Best Management Practices - Street Sweeping, Waco, Texas, 1993.

US Environmental Protection Agency, "Methods for Evaluating Solid Waste, Physical/ Chemical

US Environmental Protection Agency, Test Methods for Evaluating Solid Wastes, (SW-846), 3<sup>rd</sup> Edition, 1986.

W&H Pacific, Inc., Street and Street Sweeping Waste Characteristics Snohomish County, Washington, February 1994.

# Chapter 1 – Introduction to Volume IV

---

## 1.1 What is the Purpose of this Manual?

This manual was designed to help businesses, homeowners and public agencies in Tacoma implement source control best management practices (BMPs) to prevent pollutants from contaminating stormwater runoff and entering our rivers, lakes and streams. Human and ecosystem health, safety and welfare can be at risk from polluted stormwater. The implementation of BMPs is required by several programs, which are listed in 1.3 below. Every person/business in Tacoma is required to use BMPs. You need to select BMPs from this manual to prevent stormwater pollution. Refer to Section 1.4 below for additional information on BMPs. Information on stormwater treatment BMPs can be found in Volume I, Section 1.4 and Volume 5, particularly Chapter 2.

## 1.2 How Do I Know Whether Any of This Applies to Me?

Because of the provisions of the federal Clean Water Act and Coastal Zone Management Act, the National Pollutant Discharge Elimination System (NPDES) municipal stormwater permit, the Puget Sound Water Quality Authority Water Quality Management Plan, and Chapter 12.08 of the City Code of Tacoma, Sewage Disposal and Drainage Regulations and Rates, Including the Industrial Wastewater Pretreatment Program, the implementation of BMPs applies to all businesses, residences and public agencies in Tacoma. It includes all permanent and temporary activities at public facilities, commercial and industrial facilities, agriculture and livestock farms, and residential dwellings. Anyone involved in a particular activity, whether as an employee, supervisor, manager, landlord, tenant, or homeowner, must take part in implementing appropriate BMPs. BMPs need to be selected from this manual.

The City of Tacoma adopted the Regional Road Maintenance Endangered Species Act – Program Guidelines in 2002. This document was developed by the Tri-County Road Maintenance ESA Technical Working Group and contains guidelines for roadway maintenance operations, utility maintenance, maintenance of stormwater facilities, and other right-of-way (ROW) structure maintenance within the ROW. The goal of the Program Guidelines is to provide a consistent, regional program that can be used by any agency wishing to limit, reduce or eliminate the prohibition on take of threatened species under the 4(d) rule of the Federal Endangered Species Act. There is some overlap between this document, Volume IV of the Surface Water Management Manual, Source Control BMPs, and the above mentioned Program Guidelines. The Surface Water Management Manual, Volume IV Source Control BMPs are required as the minimum standard for source controls. The Regional Road Maintenance Manual may contain additional requirements above the Surface Water Management Manual minimum standards.

## 1.3 What Type of Pollutants are we Targeting With This Manual?

Under the NPDES permit mentioned above, the City is required to show progress in eliminating virtually all non-stormwater discharges to the storm drainage system. In other words, nothing but uncontaminated stormwater may be discharged to the City of Tacoma storm drainage system. There are severe state and federal penalties for anyone violating the terms of these permits. Illicit discharges may be intentional or unintentional, but either way are not allowed. **You must keep pollutants from leaving your property and entering the City storm drainage system.**

Pollutants can be placed into several broad categories. The descriptions provided below are quite brief, but further information on a particular pollutant can be obtained by calling one of the information numbers listed in Chapter 7.

### **pH**

The pH value of a substance gives you a relative measure of whether it is acidic or basic. The pH value of a body of water is vitally important, since most aquatic life can operate within a relatively narrow band of pH values (6 to 8). Some sources that can contribute to a change in pH of stormwater and waterbodies are cement in concrete pouring, paving and recycling operations, solutions from metal plating, chemicals from printing businesses and other industrial processes, and household cleaners such as bleaches and deck washes.

### **Total Suspended Solids**

This represents particulate solids such as eroded soil, heavy metal precipitates, and biological solids (all considered as conventional pollutants), which can cause sedimentation in streams and turbidity in receiving surface waters. These sediments can destroy the desired habitat for fish and can impact drinking water supplies. The sediment may be carried to streams, lakes, or Puget Sound where they may be toxic to aquatic life and make dredging necessary.

### **Oils and Greases**

Oils and greases can be either petroleum-based or food-related sources. Petroleum-based compounds can be immediately toxic to fish and wildlife, and if they reach our drinking water aquifers, will make us sick too. Food-based oils and greases may not be toxic to us, but they can coat fish gills and insects, and suffocate them.

### **Oxygen-demanding Substances**

Degradable organic matter, such as yard, food and pet wastes, and some chemical wastes, can have a drastic effect on water quality if they are allowed to enter stormwater. As these substances are broken down by bacteria, the oxygen in the water is consumed. This stresses and can eventually kill fish and other creatures in the water.

### **Metals**

Metals are utilized in many products important to our daily lives. Certain metals, known as heavy metals, wear off of our car brakes and tires, and come from the paint and moss-killing roof strips and herbicides we use at our homes. These metals can cause severe health and reproductive problems in fish and animals that live in water and sediments that become contaminated by runoff.

### **Bacteria and Viruses**

Bacteria and viruses from pet wastes, failing septic systems and agricultural areas can contaminate drinking water and close down swimming and shellfish areas. A group of bacteria called **fecal coliform bacteria** are typically used as the indicators for pollution by more serious disease-causing microorganisms. The Washington State Department of Ecology is proposing changes to the State Water Quality Standards that will become effective in 2003. The changes include the use of new bacterial indicators; E. Coli for fresh water and enterococci for marine water will replace fecal coliform bacteria, except that fecal coliform will still be used in marine waters that contain shellfish beds.

### **Nutrients**

In the context of water quality, nutrients are mainly compounds of nitrogen and phosphorus. When nutrients are allowed to enter waterbodies, undesirable effects such as algae overgrowth, oxygen depletion, channel clogging due to overgrowth of vegetation, and fish and animal death can occur. Sources of nutrients can include fertilizers, failing septic systems, and yard and animal wastes.

### **Toxic Organic Compounds**

A number of organic chemicals are just plain toxic when they get into the aquatic environment. Many pesticides, herbicides, rodenticides, and fungicides are deadly to aquatic life. The same is true of compounds such as antifreeze, wood preservatives, cleansers and a host of other, more exotic organics derived from industries or past practices (such as polychlorinated biphenyls (PCBs), DDT and chlordane).

### **Other Chemicals and Substances**

There are a host of other chemicals that can cause problems if allowed to enter the aquatic environment. Common household bleach can be deadly to fish and other critters if drained directly to waterbodies. Diatomaceous earth backwash from swimming pool filters can clog gills and suffocate fish. Arsenic has been used in rat and mole killing compounds. Even those compounds classified as **biodegradable or environmentally friendly** can have devastating **immediate** effects on aquatic life.

## 1.4 What Are Best Management Practices (BMPs)?

BMPs are a series of actions that are designed to reduce stormwater pollution. BMPs are separated into two broad categories, namely source control BMPs and treatment BMPs.

### 1.4.1 Source Control BMPs

As the name implies, source control BMPs prevent contamination from entering stormwater runoff by controlling them at the source. There are two categories of source control BMPs: operational and structural.

1. Operational source control BMPs are non-structural practices that prevent or reduce pollutants from entering stormwater. Examples include:
  - formation of a pollution prevention team,
  - good housekeeping practices,
  - preventive maintenance procedures,
  - spill prevention and cleanup,
  - employee training,
  - inspections of pollutant sources, and
  - record keeping.
  - They can also include process changes such as raw material/product changes and recycling wastes.

Operational source control BMPs are considered to be the most cost effective pollutant minimization practices.

2. Structural source control BMPs are physical, structural or mechanical devices or facilities that are intended to prevent pollutants from entering stormwater. Examples of structural source control BMPs typically include:
  - enclosing and/or covering the pollutant source, i.e., within a building or other enclosure, a roof over storage and working areas, a temporary tarp, etc.,
  - physically segregating the pollutant source to prevent run-on of uncontaminated stormwater,
  - devices that direct only contaminated stormwater to appropriate treatment BMPs, i.e., discharge to a sanitary sewer if allowed by the local sewer utility.

Structural BMPs typically cost more to construct, operate and maintain.

### 1.4.2 Treatment BMPs

Treatment BMPs are utilized to treat stormwater that is already contaminated. Most treatment BMPs require planning, designing, permitting and construction, and none can remove 100% of the contaminants in stormwater. These factors, added to the typical expense of treatment BMPs, makes source control BMPs the preferred choice.

There may, however, be some instances where treatment BMPs may be required. This volume identifies specific treatment BMPs that apply to particular pollutant sources, such as fueling stations, railroad yards, storage and transfer of materials, etc. After identifying the required treatment BMPs, the reader can refer to Volume I, Section 1.4 and Volume V of this manual for additional information about treatment BMPs.

## **1.5 Am I Exempted if I am Already Doing BMPs?**

Businesses already implementing BMPs in accordance with other federal, state, or local programs usually do not have to implement additional BMPs. Persons or businesses qualifying for exemptions include:

- Businesses required to obtain a general or individual National Pollutant Discharge Elimination System (NPDES) permit for stormwater discharges must comply with the requirements of that permit. See regulatory requirement R.2 in Chapter 6 of this manual for details.

If you are on the above list, the City assumes that you are implementing the appropriate BMPs. If the City finds that you have not implemented your BMPs, or that the BMPs that you have implemented are not effectively addressing the discharge of contaminants, then you may be required to enact additional BMPs to meet requirements. *Everyone* must do BMPs, but how each business goes about it, and through which government program, may differ from business to business.

## **1.6 How Do I Get Started?**

If you are a landlord, tenant or owner of a single-family residence, proceed to Chapter 3 for BMPs that are recommended for you.

If you own a business or industry, complete the worksheet in Chapter 2. If you checked off any of the activities as being performed outdoors, use the activity code on the worksheet to find the BMPs recommended for you in Chapter 4.

If you have questions, please contact the City's Stormwater Source Control Unit at (253) 591-5588. They can provide assistance over the phone and also at your business site.

## **1.7 Some Important Requirements to Note**

Under current state and local law, if you own commercial property and lease or rent it, you can be held responsible for water quality problems caused by your tenants. Make sure your tenants are informed of their responsibilities under the auspices of this manual.

Another important requirement is the need for an accidental spill plan if your business has the potential for a spill. If you are currently under a



Pretreatment permit for discharge to sewers, it will probably require a minor amount of effort to amend it to include stormwater. Please contact the City of Tacoma Source Control Unit at 253-591-5588 for information on developing these plans.

You are responsible for obtaining prior approval for your stormwater discharge to the City system. This means obtaining proper building and environmental permits from the City and State. Please contact the City of Tacoma Building and Land Use Services Division at 253-591-5030 or the Source Control Unit at 253-591-5588 for permit information. For State Department of Ecology permits, call 360-407-6400.

## Chapter 2 – Worksheets for Commercial and Industrial Activities

This worksheet is designed for use by business and industry operators. Complete the entire worksheet by checking the appropriate boxes for all activities that take place at your work place. If you checked off any of the activities as being performed outdoors, use the activity code on the worksheet to find the BMPs recommended for you in Chapter 4.

Activity Code	TYPE OF ACTIVITY	Are you involved in this? If so, check if it occurs:	
		INDOORS <sup>1</sup>	OUTDOORS <sup>2</sup>

SECTION A1 – CLEANING AND WASHING ACTIVITIES			
A1.1	Cleaning or washing of tools, engines and manufacturing equipment <ul style="list-style-type: none"> <li>This includes parts washers, and all types of manufactured equipment components.</li> </ul>		
A1.2	Cleaning or washing of cooking equipment <ul style="list-style-type: none"> <li>This includes vents, filters, pots and pans, grills, and related items.</li> </ul>		
A1.3	Washing, Pressure Washing and Steam Cleaning of Vehicles/Equipment/Building Structures <ul style="list-style-type: none"> <li>This covers cleaning and washing at all types of establishments, including fleet vehicle yards, car dealerships, car washes, and maintenance facilities.</li> </ul>		
A1.4	Collection and disposal of wastewater from mobile interior washing operations <ul style="list-style-type: none"> <li>This includes carpet cleaners, upholstery cleaners, and drapery cleaners.</li> </ul>		

SECTION A2 – TRANSFERS OF LIQUID OR SOLID MATERIALS			
A2.1	Loading and Unloading Areas for Liquid or Solid Material <ul style="list-style-type: none"> <li>Loading and unloading of materials at industrial and commercial facilities</li> </ul>		
A2.2	Fueling at dedicated stations <ul style="list-style-type: none"> <li>This includes gas stations, pumps at fleet vehicle yards or shops, and other privately owned pumps.</li> </ul>		
A2.3	Engine repair and maintenance <ul style="list-style-type: none"> <li>This covers oil changes and other engine fluids.</li> </ul>		
A2.4	Mobile fueling of vehicles and heavy equipment <ul style="list-style-type: none"> <li>Fleet fueling, wet fueling and wet hosing</li> </ul>		

Activity Code	TYPE OF ACTIVITY	Are you involved in this? If so, check if it occurs:	
		INDOORS <sup>1</sup>	OUTDOORS <sup>2</sup>

SECTION A3 – PRODUCTION AND APPLICATION ACTIVITIES			
A3.1	Concrete and asphalt mixing and production at stationary sites. <ul style="list-style-type: none"> <li>Applies to mixing of raw materials on-site to produce concrete or asphalt.</li> </ul>		
A3.2	Concrete pouring, concrete cutting, and asphalt application at temporary sites <ul style="list-style-type: none"> <li>This includes construction sites, and driveway and parking lot resurfacing.</li> </ul>		
A3.3	Manufacturing and post-processing of metal products <ul style="list-style-type: none"> <li>This includes machining, grinding, soldering, cutting, welding, quenching, rinsing, etc.</li> </ul>		
A3.4	Wood treatment areas <ul style="list-style-type: none"> <li>This includes wood treatment using pressure processes or by dipping or spraying.</li> </ul>		
A3.5	Commercial composting <ul style="list-style-type: none"> <li>Includes commercial composting facilities operating outside.</li> </ul>		
A3.6	Landscaping and vegetation management activities, including vegetation removal, herbicide and insecticide application, fertilizer application, irrigation, watering, gardening, and lawn care. <ul style="list-style-type: none"> <li>Includes businesses involved in landscaping, applying pesticides and in managing vegetation.</li> </ul>		
A3.7	Painting, finishing and coating of vehicles, boats, buildings and equipment. <ul style="list-style-type: none"> <li>Includes surface preparation and the applications of paints, finishes and/or coatings.</li> </ul>		
A3.8	Commercial printing operations <ul style="list-style-type: none"> <li>Includes materials used in the printing process.</li> </ul>		
A3.9	Manufacturing Activities – Outside <ul style="list-style-type: none"> <li>Includes outdoor manufacturing areas.</li> </ul>		

Activity Code	TYPE OF ACTIVITY	Are you involved in this? If so, check if it occurs:	
		INDOORS <sup>1</sup>	OUTDOORS <sup>2</sup>

SECTION A4 – STORAGE ACTIVITIES			
A4.1	Storage or transfer (outside) of solid raw materials, by-products or finished products		
A4.2	Storage and treatment of contaminated soils <ul style="list-style-type: none"> <li>This applies to contaminated soils that are excavated and left on-site.</li> </ul>		
A4.3	Temporary storage or processing of fruits or vegetables <ul style="list-style-type: none"> <li>This includes processing activities at wineries, fresh and frozen juice makers, and other food and beverage processing operations.</li> </ul>		
A4.4	Storage of solid wastes and food wastes <ul style="list-style-type: none"> <li>This includes regular garbage and all other discarded non-liquid items.</li> </ul>		
A4.5	Recyclers and scrap yards <ul style="list-style-type: none"> <li>This includes scrapped equipment, vehicles, empty metal drums, and assorted recyclables.</li> </ul>		
A4.6	Treatment, storage, or disposal of dangerous wastes. <ul style="list-style-type: none"> <li>Refer to Ecology and the Tacoma-Pierce County Health Department for more information, see Chapter 6.</li> </ul>		
A4.7	Storage of liquid, food waste or dangerous waste containers <ul style="list-style-type: none"> <li>This includes containers located outside a building and used for temporary storage</li> </ul>		
A4.8	Storage of liquids in permanent above-ground tanks <ul style="list-style-type: none"> <li>Includes all liquids in above-ground tanks</li> </ul>		
A4.9	Parking and storage for vehicles and equipment <ul style="list-style-type: none"> <li>Includes public and commercial parking lots</li> </ul>		
A4.10	Loading and unloading areas for solid materials <ul style="list-style-type: none"> <li>(Refer to A2.1 Loading and unloading areas for liquid and solid materials.</li> </ul>		

Activity Code	TYPE OF ACTIVITY	Are you involved in this? If so, check if it occurs:	
		INDOORS <sup>1</sup>	OUTDOORS <sup>2</sup>

<b>SECTION A5 – CONSTRUCTION ACTIVITIES</b>			
A5.1	Clearing, grading, and preparation of construction sites. <ul style="list-style-type: none"> <li>Applies to land developing activities and to residential yard clearing and grading projects.</li> </ul>		
A5.2	Demolition of buildings. <ul style="list-style-type: none"> <li>Applies to removal of existing buildings and subsequent clearing of the rubble.</li> </ul>		
A5.3	Building repair, remodeling and construction. <ul style="list-style-type: none"> <li>Applies to construction of buildings, general exterior building repair work and remodeling of buildings.</li> </ul>		

<b>SECTION A6 – DUST CONTROL AND SOIL AND SEDIMENT CONTROL</b>			
A6.1	Dust control at disturbed land areas and unpaved roadways and parking lots		
A6.2	Dust control at manufacturing sites <ul style="list-style-type: none"> <li>Includes grain dust, sawdust, coal, gravel, crushed rock, cement and boiler fly ash.</li> </ul>		
A6.3	Soil erosion and sediment control at industrial sites <ul style="list-style-type: none"> <li>Includes industrial activities that take place on soil.</li> </ul>		

<b>SECTION A7 – OTHER ACTIVITIES</b>			
A7.1	Commercial animal handling areas <ul style="list-style-type: none"> <li>This includes kennels, fenced pens, veterinarians and businesses that board animals</li> </ul>		
A7.2	Log sorting and handling <ul style="list-style-type: none"> <li>Applies to log yards typically located at sawmills, ports and pulp mills.</li> </ul>		
A7.3	Boat building, mooring, maintenance, and repair <ul style="list-style-type: none"> <li>This includes all types of maintenance, repair, and building operations.</li> </ul>		
A7.4	Logging <ul style="list-style-type: none"> <li>Applies to logging activities that fall under Class IV general forest practices.</li> </ul>		

Activity Code	TYPE OF ACTIVITY	Are you involved in this? If so, check if it occurs:	
		INDOORS <sup>1</sup>	OUTDOORS <sup>2</sup>
A7.5	Mining and quarrying of sand, gravel, minerals, peat, clay, rock, and other materials <ul style="list-style-type: none"> <li>This does not include excavation at construction sites.</li> </ul>		
A7.6	Swimming pool and spa cleaning and maintenance <ul style="list-style-type: none"> <li>This includes every swimming pool and spa not at a single family residence. Commercial pool cleaners are included here for all pools.</li> </ul>		
A7.7	Deicing and anti-icing operations for airports and streets <ul style="list-style-type: none"> <li>Includes aircraft, runways/taxiways, streets and highways.</li> </ul>		
A7.8	Roof and building drains at manufacturing and commercial buildings <ul style="list-style-type: none"> <li>These sites will be referred to the Puget Sound Clean Air Agency.</li> </ul>		
A7.9	Urban streets <ul style="list-style-type: none"> <li>Includes recommended BMPs.</li> </ul>		
A7.10	Railroad yards		
A7.11	Maintenance of public and private utility corridors and facilities <ul style="list-style-type: none"> <li>Includes public and private utility maintenance activities.</li> </ul>		
A7.12	Maintenance of roadside ditches		
A7.13	Maintenance of stormwater drainage and treatment facilities		
A7.14	Spills of oil and hazardous substances		

<sup>1</sup>If you checked off any of these activities as occurring **indoors** at your business, then you are exempt from implementing BMPs, provided no indoor drains or processes can ultimately contact stormwater or be transported to surface waters such as rivers, lakes and streams. You must ensure that liquids, powders, dusts and fine granular materials stay confined indoors, otherwise you will be subject to all of the BMP requirements.

<sup>2</sup>If you checked off any of these activities as occurring **outdoors** at your business, then use the activity code to find the appropriate BMPs described in Chapter 4.

# Chapter 3 – Best Management Practices for Single-Family Residences

---

The actions we take each day in and around our homes have a profound effect on surface water quality and fish habitat in this region. Stormwater goes directly to our lakes, streams and to Puget Sound. It does not go to the wastewater treatment plant. Any pollutants that get into the stormwater go directly to surface water. Small amounts of pollution from many different sources can significantly affect our waterways. Yard maintenance, waste storage, car washing and maintenance, and pool cleaning are some of the activities that can adversely impact water quality. The best management practices (BMPs) discussed in this section are practical ways to keep stormwater from becoming polluted in the first place. It is recommended that all residents in Tacoma use these BMPs. **Please note that some of these procedures are required by various state, or city laws, and are noted as required BMPs.**

Here's a general list of best management practices (BMPs) for citizens. The list includes brief information on applicability. For more information on the following BMPs, refer to the information in Sections 3.1 through 3.7 of this chapter.

## **Automobile Washing (3.1)**

**At Home:** Wash your car on grass or gravel. Use a nozzle on your hose. Use soaps and detergents that are biodegradable and that don't contain phosphates. Pour the bucket of dirty water down your sink so it goes to the wastewater treatment plant.

**Away from Home:** Use a commercial car wash or go to a fund raising car wash that uses a City of Tacoma Clean Bay Car Wash loaner kit. Reserve your own Clean Bay Car Wash loaner kit for your fundraising car wash.

## **Automobile Maintenance (3.2)**

Fix leaks. Recycle all oils, antifreeze, solvents, contaminated gasoline, and batteries. Don't mix wastes. Don't dump anything on the ground or down a storm drain!

## **Storage of Solid Wastes and Food Wastes (3.3)**

Recycle as much as you can. Purchase products which have the least amount of packaging material. Keep your waste area clean.

## **Composting (3.4)**

Locate compost piles on unpaved areas and away from wetlands, streams and drainage paths. Cover the compost pile.

## **Yard Maintenance and Gardening (3.5)**

Follow the exact directions when using pesticides, herbicides and fertilizers. Don't apply in the wind or when rain is expected. Don't apply within 100 feet of streams, lakes and wetlands. Use the City's curbside yard waste recycling program.

Consider “Green Gardening” practices such as using a mulching mower and mowing higher which helps improve soil/grass health and reduces the need for fertilizers and pesticides. Consider planting vegetation suited to the Northwest climate.

### **Swimming Pool and Spa Cleaning and Maintenance (3.6)**

Pool and spa water must be dechlorinated before the pool or spa is emptied, or else it must go to the sanitary sewer. Hire a professional pool service company for help if you need it. Store all hazardous materials out of the reach of children, and in a manner that prevents chemical reactions.

### **Household Hazardous Material, Use, Storage and Disposal (3.7)**

Recycle! Use the City’s Household Hazardous Waste facility located at the landfill. Store all hazardous materials out of the reach of children. Follow the manufactures’ directions for use of all materials.

## **3.1 Automobile Washing**

Most residents wash their cars in the driveway or on the street. Washwaters typically flow to a storm drain or ditch, which discharges stormwater directly to the nearest stream, lake or to Puget Sound. Soaps and detergents, even the biodegradable ones, can have immediate and long-term effects on critters living in waterbodies. The grime washed off the car also contains a variety of pollutants that can harm fish and wildlife.

### **Suggested BMPs**

#### **At Home:**

- Wash your car directly over your lawn or make sure the wash water drains to a vegetated area. This allows the water and soap to soak into the ground instead of running off into a local waterbody.
- Ideally, no soaps or detergents should be used, but if you do use one, select one without phosphates.
- Sweep driveways and street gutters **before** washing vehicle to clean up dirt, leaves, trash and other materials that may flow to the storm drain along with your wash water. This helps reduce storm drain maintenance costs as well as protect water quality.
- Commercial products are available that allow you to clean a vehicle without water. These were developed for areas where water is scarce, so a water saving benefit is realized as well as reduced pollution.
- Use a hose nozzle with a shut-off valve to save water.
- Do not wash your car if rain is expected.



- Pour the bucket of soapy, dirty washwater down your sink. This way the water doesn't pollute surface water. Instead, it's treated at the wastewater treatment plant.

#### **Away from Home:**

- Consider not washing your car at home. Take it to a commercial car wash that has a recycle system and discharges wastewater to the sanitary sewer for treatment.
- Go to fundraising car washes where sponsors use Tacoma's Clean Bay Car Wash loaner kits. Look for the Clean Bay Car Wash logo. Use a Clean Bay Car Wash loaner kit. If your group is planning a car wash in Tacoma, call 253-502-2120 to reserve a Clean Bay Car Wash loaner kit.

### **3.2 Automobile Maintenance**

Many of us are "weekend mechanics". We enjoy the cost savings of changing our own oil and antifreeze, topping off the battery with water, and generally making our car perform its' best. There is a lot of potential for stormwater pollution associated with these activities; however, the following BMPs will help you minimize pollution while servicing your car.

#### **Required BMPs**

- **Recycle all oils, antifreeze, solvents and batteries. Many local car parts dealers and gas stations accept used oil. The Household Hazardous Waste facility at the Tacoma Landfill accepts oil, oil filters, antifreeze and solvents. Old batteries can actually be worth money. Call shops listed under Batteries in the Yellow Pages of the phone book to find out if they are paying for used batteries. Use the numbers listed in Chapter 7 to call for more information.**
- **Never dump new or used automotive fluids or solvents on the ground, in a storm drain or street gutter, or in a waterbody. Eventually, it will make its way to local surface waters or groundwater, including the water we drink.**
- **Do not mix wastes. The chlorinated solvents in some carburetor cleaners can contaminate a huge tank of used oil, rendering it unsuitable for recycling. Always keep your wastes in separate containers which are properly labeled and store them out of the weather.**

#### **Suggested BMPs**

- Fix all leaks, to keep the leaky material off the streets and out of the surface water.

- To dispose of oil filters, punch a hole in the top and let drain for 24 hours. This is where a large funnel in the top of your oil storage container will come in handy. After draining, wrap in 2 layers of plastic and dispose of in your regular garbage or recycle by taking it to the Tacoma Landfill, Household Hazardous Waste facility. Pending State law may make disposal in your home garbage illegal, so please call the Hazardous Waste line at 1-800-287-6429 for up-to-date information.
- Use care in draining and collecting antifreeze to prevent accidental spills. Spilled antifreeze can be deadly to cats and dogs that ingest it.
- Perform your service activities on concrete or asphalt or over a plastic tarp to make spill clean-up easier. Keep a bag of kitty litter on hand to absorb spills. Sprinkle a good layer on the spill, let it absorb for a little while and then sweep it up. Place the contaminated litter in a plastic bag, tie it up, and dispose of it in your regular garbage. Take care not to leave kitty litter out in the rain; it will form a sticky goo that is hard to clean up.
- If you are doing body work outside, be sure to use a tarp to catch material resulting from grinding, sanding and painting. Dispose of this waste by double bagging in plastic and placing in your garbage.

### **3.3 Storage of Solid Wastes and Food Wastes**

Improper storage of food and solid waste at residences can lead not only to water pollution problems, but problems with neighborhood pets and vermin as well. Following the BMPs listed below can help keep your property a clean and healthy place to live.

#### **Suggested BMPs**

- All waste containers kept outside should have lids. If your lid is damaged, please call Tacoma Solid Waste Management at 591-5543 to get the lid repaired or replaced.
- Leaking waste containers should be replaced. If your container is damaged, please call Tacoma Solid Waste Management at 253-591-5543.
- Store waste containers under cover if possible, or on grassy areas.
- Use the Tacoma Call-2-Haul program to pick up bulky materials and excess waste material. Call 253-573-2468 for more information and details, or to set up an appointment for waste pickup.
- Inspect the storage area regularly to pick up loose scraps of material and dispose of them properly.

- Recycle as much as you can. Tacoma offers curbside recycling. Also, look under "Recycling" in the phone book for firms which take other recyclables.
- Purchase products which have the least amount of packaging materials.
- Compost biodegradable materials such as grass clippings and vegetable scraps instead of throwing them away. Your flowerbeds will love the finished compost, and we won't fill up our landfills so quickly. Call Tacoma Solid Waste Utility Recycling and Composting at 253-565-5955 for more information on composting. See the section on Composting for BMPs relating to that activity.
- A fun alternative to traditional composting is worm composting. You can let worms do all the work for you by keeping a small vermiculture box just outside your kitchen. For more information on getting started with worms, call the number listed above.

### **3.4 Composting**

Composting is an earth-friendly activity as long as some common sense rules outlined below are followed. If you choose to compost, the following BMPs should be utilized.

#### **Suggested BMPs**

- Compost piles must be located on an unpaved area where runoff can soak into the ground or be filtered by grass and other vegetation. Compost piles should be located in an area of your yard not prone to water ponding during storms, and should be kept well away from wetlands, streams, lakes and other drainage paths.
- Compost piles must be maintained and turned over regularly to work properly. Large piles of unattended compost may create odor and vermin problems.
- Avoid putting hazardous or non-decomposable waste in the pile.
- Cover the compost pile for two reasons:
  1. To keep stormwater from washing nutrients into waterways.
  2. To keep excess water from cooling down the pile, which will slow down the rate of decomposition.
- Build bins of wood, chicken wire or fencing material to contain compost so it can't be washed away. Call Tacoma Solid Waste Utility Recycling and Composting at 565-5955 to get free composter designs and materials lists.

- Building a small earthen dike around your compost pile is an effective means of preventing nutrient-rich compost drainage from reaching stormwater paths.

### 3.5 Yard Maintenance and Gardening

This section deals with the normal yard maintenance activities we all perform at our homes. Overwatering, overfertilizing, improper herbicide application and improper disposal of trimmings and clippings can all contribute to serious water pollution problems. Following the BMPs listed below will help alleviate pollutant runoff.

#### Required BMPs

- **Follow the manufacturer's directions exactly for mixing and applying herbicides, fungicides and pesticides, and use them sparingly. Never apply when it is windy or when rain is expected. Never apply over water, within 100 feet of a well-head, or adjacent to streams, wetlands, or other waterbodies. Triple-rinse empty containers, using the rinsate for mixing your next batch of spray, and then double-bag and dispose of the empty container in your regular garbage. Never dispose of grass clippings or other vegetation in or near storm drains, streams, lakes or Puget Sound.**

#### Suggested BMPs

- Use natural, organic soil amendments like Tacoma's TAGRO Mix. TAGRO Mix is a 100% recycled blend of de-watered, Class A, "Exceptional Quality" biosolids, mixed with sawdust and sand. The excellent soil conditioning properties of the organic matter aid water retention in lighter soils and help to break up and aerate heavier soils, so roots can grow better and less watering is needed. It contains both readily available and long term nitrogen and other nutrients commonly lacking in Northwest soils. The slow release of nitrogen better matches the needs of plants. Thus, there is much less potential for nitrates to leach into surface or ground water due both to less "excess nitrogen" and also less water use. Better vegetative growth can also reduce erosion and runoff.
- Use an integrated pest management program (IPM), which is a natural, long-term, ecologically based approach to controlling pest populations. See Chapter 4, Activity A3.6 Landscaping and Lawn/Vegetation Management and Appendix IV-B Example of an Integrated Best Management Program.
- Follow manufacturer's directions when applying fertilizers. More is not better, either for your lawn or for local waterbodies. Never apply fertilizers over water or adjacent to ditches, streams or other water

bodies. Remember that organic fertilizers have a slow release of nitrogen, and less potential to pollute than synthetic fertilizers.

- Save water and prevent pollution problems by watering your lawn sensibly. Lawns and gardens typically need the equivalent of 1" of rainfall per week. You can check on how you're doing by putting a wide mouth jar out where you're sprinkling, and measure the water with a small plastic ruler. Overwatering to the point of runoff can carry polluting nutrients to the nearest waterbody.
- Consider planting a vegetated buffer zone adjacent to streams or other water bodies on your property. Call the Pierce County Conservation District at 253-845-2973 for advice and assistance in developing a planting plan. The Stream Team at the Conservation District may even be able to help you plant it!
- Reduce the need for pesticides and fertilizers on lawns by improving the health of the soil. Aeration, thatching and topdressing with compost will improve soil health and help wanted grasses compete with weeds and moss.
- Make sure all fertilizers and pesticides are stored in a covered location. Rain can wash the labels off of bottles and convert 50 lbs. of fertilizer into either a solid lump or a river of nutrients.
- Use a mulching mower and mow higher to improve soil/grass health and to reduce or eliminate pesticide use.
- Compost all yard clippings, or use them as mulch to save water and keep down weeds in your garden. See Composting section for more information.
- Practice organic gardening and virtually eliminate the need to use pesticides and fertilizers. Contact Pierce County Cooperative Extension at 591-7180 or the Ask-A-Master Gardener program at 591-7170 for information and classes on earth-friendly gardening.
- Pull weeds instead of spraying and get some healthy exercise, too. If you must spray, use the least toxic formulations that will get the job done. The Master Gardener program listed above can help advise you on which spray to use.
- Work fertilizers into the soil instead of letting them lie on the ground surface exposed to the next rain storm.
- Plant vegetation suited to Northwest conditions because they require less water and fewer to no fertilizers and pesticides.
- Tacoma has a curbside yard waste recycling program. Call 253-565-5955 for more information.

### **3.6 Swimming Pool and Spa Cleaning and Maintenance**

Despite the fact that we immerse ourselves in it, the water from pools and spas is far from chemically clean. Nutrients, pH, and chlorine can adversely affect fish and wildlife in waterbodies. Following these BMPs will ensure the cleanliness of your pool and the environment.

#### **Required BMPs**

- **Pool and spa water must be dechlorinated if it is to be emptied into a ditch, on the ground, or a lawn or to the storm drainage system. Contact your pool chemical supplier to obtain the neutralizing chemicals you will need. The rate of flow into the ditch or drainage system must be regulated so that it does not cause problems such as erosion, surcharging or flooding. Water discharged to the ground or a lawn must not cross property lines and must not produce runoff.**
- **If pool and spa water cannot be dechlorinated, it must be discharged to the sanitary sewer. Prior to draining, your local wastewater treatment plant must be notified to ensure they are aware of the volume of discharge and the potential effects of chlorine levels. A pool service company can help you determine the frequency of cleaning and backwash of filters.**
- **Diatomaceous earth used in pool filters cannot be disposed of in surface waters, on the ground, into storm drainage systems or septic systems. Dry it out as much as possible, bag it in plastic, and dispose of at the landfill.**

#### **Suggested BMPs**

- Hire a professional pool service company to collect all pool water for proper disposal. Make sure to ask them where they will dispose of it and the kind of permits they hold to do so.

### **3.7 Household Hazardous Material Use, Storage and Disposal**

Once we really start looking around our houses, the amount of hazardous materials we have on site is a real eye-opener. Oil-based paints and stains, paint thinner, gasoline, charcoal starter fluid, cleaners, waxes, pesticides, fingernail polish remover, and wood preservatives are just a few that most of us have around the house.

When products such as these are dumped on the ground or in a storm drain, they can be washed directly to receiving waters where they can harm fish and wildlife. They can also infiltrate into the ground and contaminate drinking water supplies. The same problem can occur if they

are disposed of with your regular garbage; the containers can leak at the landfill and contaminate groundwater. The same type of contamination can occur if hazardous products are poured down a sink or toilet into a septic system. Don't pour them down the drain if you're on municipal sewers, either. Many compounds will "pass through" the wastewater treatment plant without treatment and contaminate receiving waters, or they can harm the biological process used at the treatment plant, reducing overall treatment efficiency.

With such a diversity of hazardous products present in all homes in Tacoma, a large potential for serious environmental harm exists if improper methods of storage, usage and disposal are employed. Using the following BMPs will help keep these materials out of our soils, sediments and waters.

### **Required BMPs**

- **Hazardous materials must be stored out of the reach of children. Never transfer to or store these materials in food or beverage containers which could be misinterpreted by a child as something to eat or drink.**
- **Dispose of hazardous materials and their containers properly. Never dump products labeled as *poisonous, corrosive, caustic, flammable, inflammable, volatile, explosive danger, warning, caution or dangerous* outdoors, in a storm drain, or into sinks, toilets or drains. Call the Household Hazardous Waste Facility at (253) 591-5418 or the Hazardous Waste Line at 1-800-287-6429 for information on disposal methods, collection events, and alternative products. Household hazardous wastes from City of Tacoma residents are accepted at the Tacoma Landfill.**

### **Suggested BMPs**

- Check hazardous material containers frequently for signs of leakage. If a container is rusty and has the potential of leaking soon, place it in a secondary container before the leak occurs and prevent a clean-up problem.
- Store hazardous materials containers under cover and off the ground. Keep them out of the weather to avoid rusting, freezing, cracking, labels being washed off, etc.
- Keep appropriate spill cleanup materials on hand. Kitty litter is good for many oil-based spills.
- Ground cloths and drip pans must be used under any work outdoors which involves hazardous materials such as oil-based paints, stains, rust removers, masonry cleaners, and others bearing label warnings as outlined above.

- Latex paints are not a hazardous waste, but are not accepted in liquid form at the landfill. To dispose, leave uncovered in a protected place until dry, then place in the garbage. If you wish to dry waste paint quickly, just pour kitty litter in the can to absorb the paint. Once paint is dry, leave the lid off when you place it in the garbage so your garbage collector can see that it is no longer liquid.
- Use less toxic products whenever possible. The Hazardous Waste Line at 1-800-287-6429, and the Washington Toxics Coalition at 206-632-1545 have information detailing alternatives to toxic products.
- If an activity involving the use of a hazardous material can be moved indoors out of the weather, then do so. Make sure you can provide proper ventilation, however.
- Follow manufacturers' directions in the use of all materials. Over-application of yard chemicals, for instance, can result in the washing of these compounds into receiving waterbodies. Never apply pesticides when rain is expected.
- When hazardous materials are in use, place the container inside a tub or bucket to minimize spills.
- Purchase only the amount of product that's needed.



# Chapter 4 – Best Management Practices for Commercial and Industrial Activities

---

## 4.1 Begin with Chapter 2, Worksheet for Commercial and Industrial Activities

This chapter coordinates with the worksheet that you completed in Chapter 2. That worksheet and the BMPs are organized by the different activities that businesses perform. If you perform the listed activity indoors, controlling all discharges from the activity (e.g., process water, wash water, lubricants, solvents, fugitive dust, granular material, blowdown waste, etc.) such that no exposure to stormwater occurs, then you do not have to institute new BMPs for that activity. However, if you checked the column for activities performed outdoors, match the number from the worksheet to the activities listed in this section to find the suggested BMPs you should utilize.

If you have questions, please contact the City's Stormwater Source Control Unit at 253-591-5588. They can provide assistance over the phone and are also available for consultations at your business site.

## 4.2 Explanation of Required BMPs

**Every person/business in Tacoma is required to use BMPs.** You need to select BMPs from this manual. The required BMPs are in **bold** text. Please note that in some instances there are required BMPs that are mandated by various federal, state, or city laws. You are encouraged to utilize additional BMPs to further protect our water quality. For instance, if only one BMP is required, you may wish to couple it with another BMP to prevent pollution from ever getting into stormwater in the first place.

Some businesses are or will be required to obtain a National Pollutant Discharge Elimination System (NPDES) permit for stormwater discharges. These permits are issued and regulated by the Washington State Department of Ecology. Businesses that are regulated under the NPDES stormwater program are exempt from implementing the BMPs outlined in this manual, since they will be implementing BMPs required by the state. Refer to Volume I, Section 1.6.5 and Section 6.5 of this Volume for more information about NPDES permits for industries.

The BMPs outlined in this manual are focused on source control: that is, using methods to prevent pollution from ever getting into stormwater in the first place. Many of these BMPs are common sense and "housekeeping" issues. For instance, you can sweep an indoor or outdoor work area instead of hosing it into a storm drain or other drainage conveyance. The use of source control BMPs is always the first line of defense in stormwater pollution prevention efforts for several reasons:

- In the majority of cases, source control BMPs are all that is needed to correct stormwater pollution problems.
- Most source control BMPs are relatively inexpensive and easy to implement.
- Treatment BMPs are utilized after pollution has entered stormwater. These BMPs are expensive, and can never remove 100% of the pollution in stormwater. It is far better to use source control BMPs where possible and prevent the pollution in the first place. This volume identifies specific treatment BMPs that apply to particular pollutant sources, such as fueling stations, railroad yards, storage and transfer of materials, etc. Additional information about treatment BMPs are found in Volume V of this manual.

(NOTE: At times, the type of pollutants present or the condition of a site could mean treatment BMPs are required.)

The minimum requirements for stormwater source control are contained in Volume I, Minimum Technical Requirements and Site Planning, Chapter 3, Section 3.5.3 Minimum Requirement #3 Source Control of Pollution. In accordance with this minimum requirement, all known, available and reasonable source control BMPs shall be applied to all projects. Chapter 5 of this volume contains details on many source control BMPs, with references to appropriate documents for others.

#### **4.2.1 Stormwater Treatment**

Stormwater treatment may also be required for certain types of businesses, based on the information provided in this volume and in Volume I, Minimum Technical Requirements and Site Planning, Chapter 3, Minimum Requirements for New Development and Redevelopment, Section 3.5.6 Minimum Requirement #6 Runoff Treatment and in Volume 5, Runoff Treatment BMPs. Volume 5, Runoff Treatment BMPs, contains detailed information about stormwater treatment BMPs.

### **4.3 BMPs To Consider for all Activities**

Before we get to the list of activity specific BMPs, here is a summary of items that each business should consider. As stated before, most of these are common sense, housekeeping types of solutions, but if each business would take some action on each of these, the improvement in water quality would be substantial.

#### **1. Avoid the activity or reduce its occurrence**

If you can, avoid the activity or do it less frequently. Is there a substitute process or a different material you can use to get the job done? Can you do a larger run of a process at one time, thus reducing the number of times per week or month it needs to be repeated? For instance, raw

materials could be delivered close to the time of use instead of being stockpiled and exposed to the weather. Perhaps you could avoid one solvent-washing step altogether. The City's Source Control staff, the Department of Ecology or the Tacoma-Pierce County Health Department can provide pollution prevention assistance.

## **2. Move the activity indoors**

Sometimes it is fairly easy to move an activity indoors out of the weather. The benefits of this are twofold; you prevent runoff contamination, and you provide for easier, more controlled cleanup if a spill occurs. An example would be unloading and storing barrels of chemicals inside a garage area instead of doing it outside. Please be aware that moving storage areas indoors may require installation of fire suppression equipment or other building modifications as required by the Uniform Building Code, the Uniform Fire Code, or local ordinances.

## **3. Spills**

Promptly contain and clean up solid and liquid pollutant leaks and spills including oils, solvents, fuels, and dust from manufacturing operations on any exposed soil, vegetation, or paved area.

## **4. Use less material**

Don't buy or use more material than you really need. This not only helps keep potential disposal, storage and pollution problems to a minimum, but will probably save you money, too.

## **5. Use the least toxic materials available**

Investigate the use of materials that are less toxic than what you use now. Perhaps a caustic-type detergent or a solvent could be replaced with a more environmentally friendly product. Such a change might allow you to discharge process water to the sanitary sewer instead of paying for expensive disposal (contact the Tacoma Sanitary Source Control Unit at 253-591-5588 to find out about allowable sanitary discharges and pretreatment permits). Remember that even if you do switch to a biodegradable product, nothing but uncontaminated water is allowed to enter the storm drain system.

## **6. Create and maintain vegetated areas near activity locations**

Vegetation of various kinds can help filter pollutants out of stormwater, so it is advisable to route stormwater through vegetated areas located near your activity. For instance, many parking lots contain grassy islands, typically formed in a "hump". By creating those islands as depressions instead of humps, they can be used to treat runoff from the parking lot or roof. For high use sites, conveyance to an oil removal system may be required. For more information on high use sites, refer to Volume I,

Section 4.2, Step V, Step 2. Also, don't forget the erosion control benefits of vegetation at your site.

### **7. Locate activities as far as possible from surface drainage paths**

Activities located as far as possible from known drainage paths, ditches, streams, other waterbodies, and drains will be less likely to pollute, since it will take longer for material to reach the drainage feature. This gives you more time to react in the event of a spill, or if it is a "housekeeping" issue, may protect the local waters long enough for you to clean up the area around the activity. Don't forget that groundwater issues are always prominent, no matter where the activity is located, so the actions taken on your site on a day-to-day basis are always important, even in dry weather.

### **8. Keep storm drain systems clean**

Pollutants can concentrate over time in storm drainage structures such as catch basins, ditches and storm drains. When a large storm event occurs, it can mobilize these pollutants and carry them to receiving waters. Develop and implement maintenance practices, inspections, and schedules for treatment devices (e.g., detention ponds, oil/water separators, vegetated swales, etc.). Requirements for cleaning catch basins will be discussed later in the *specific BMP S.9*.

### **9. Reduce, reuse and recycle as much as possible**

Always look for ways to recycle instead of just disposing. This can save money as well as keep both hazardous and non-hazardous materials out of the landfills. You can learn more about other businesses that have made process changes allowing recycling of chemicals by calling the DOE at 1-800-RECYCLE and requesting publication #92-45 and 90-22. Another unique recycling opportunity for businesses is available through the Industrial Materials Exchange (IMEX). This free service acts as a waste or surplus "matchmaker", helping one company's waste become another company's asset. For instance, waste peach pits from a cannery become potpourri ingredients to another business. Call IMEX at 206-625-6232 to list your potentially usable solid or chemical waste in their publication.

### **10. Be an advocate for stormwater pollution prevention**

Help friends, partners and business associates find ways to reduce stormwater pollution in their activities. Most people want clean water, and do not pollute intentionally. Share your ideas and the BMPs in this manual to get them thinking about how their everyday activities affect water quality.

## **11. Report violators**

Allowing anyone to pollute our water resources is wrong. We all must do our part to protect water, fish, wildlife and our own health, by employing proper BMPs, and reporting those who are causing pollution. Call the City of Tacoma's Source Control Unit at 253-591-5588 to report incidents involving sewers or storm drains.

## **12. Oversight and Training**

Assign one or more individuals to be responsible for stormwater pollution control. Hold regular meetings to review the overall operation of the BMPs. Establish responsibilities for inspections, operation and maintenance, and availability for emergency situations. Train all team members in the operation, maintenance and inspections of BMPs, and reporting procedures.

## **13. Dust Control**

Sweep paved material handling and storage areas regularly as needed, for the collection and disposal of dust and debris that could contaminate stormwater. Do not hose down pollutants from any area to the ground, storm drain, conveyance ditch, or receiving water unless necessary for dust control purposes to meet air quality regulations and unless the pollutants are conveyed to a treatment system approved by the City.

## **14. Maintenance**

- Clean oils, debris, sludge, etc. from all BMP systems regularly, including catch basins, settling/detention basins, oil/water separators, boomed areas, and conveyance systems, to prevent the contamination of stormwater.
- Promptly repair or replace all substantially cracked or otherwise damaged paved secondary containment, high-intensity parking and any other drainage areas, which are subjected to pollutant material leaks or spills.
- Promptly repair or replace all leaking connections, pipes, hoses, valves, etc. which can contaminate stormwater.

Maintenance standards can be found in Volume 3, Chapter 3 and in Volume 5, Chapter 4 of this manual.

**SECTION A1**  
**CLEANING AND WASHING ACTIVITIES**

## **A1.1 CLEANING OR WASHING OF TOOLS, ENGINES AND MANUFACTURING EQUIPMENT**

**Description of Pollutant Sources:** This activity applies to businesses and public agencies that clean manufacturing equipment such as saws, grinders, screens, and other processing devices outside of buildings, and to businesses engaged in pressure washing of engines, equipment and portable objects.

Pollutants sources include toxic hydrocarbons, organic compounds, oils and greases, nutrients, heavy metals, pH, suspended solids, biochemical oxygen demand (BOD), and chemical oxygen demand (COD).

**Pollutant Control Approach:** The preferred approach is to cover and/or contain the cleaning activity, or conduct the activity inside a building, to separate the uncontaminated stormwater from the pollutant sources. Washwater must be conveyed to a sanitary sewer after approval by the City of Tacoma, temporarily stored before proper disposal, or recycled, with no discharge to the ground, to a storm drain, or to surface water. Washwater may be discharged to the ground after proper treatment in accordance with *Ecology guidance WQ-R-95-56, "Vehicle and Equipment Washwater Discharges," June 1995*. The quality of any discharge to the ground after proper treatment must comply with Ecology's Ground Water Quality Standards, Chapter 173-200 WAC. Contact the local Ecology Regional Office for an NPDES Permit application for discharge of washwater to surface water or to a storm drain after on-site treatment.

### **Required BMPs**

**The following BMPs, or equivalent measures, are required of all businesses and public agencies engaged in cleaning or washing of tools, engines, equipment and portable objects:**

- **Illicit connections to the storm drainage system must be eliminated. See BMP S.1 in Chapter 5 for detailed information.**
- **Employees should be educated to control washing operations to prevent stormwater contamination.**
- **All washwater must discharge to a holding tank, process treatment system, or sanitary sewer, never to the storm drain system. See BMP S.3 in Chapter 5 for detailed information on how this must be accomplished.**
- **Pressure washing must be done in a designated area (such as a wash pad) provided with a sump drain and stormwater run-on prevention. See BMPs S.6 and S.7 in Chapter 5 for information on sumps (or holding tanks) and run-on prevention. Contact the Tacoma Sanitary Source Control Unit at 591-5588 for washing operation policy.**

## Recommended BMPs

The following BMPs are not required, but they can provide additional pollution control:

- If soaps or detergents are used, use the least toxic cleaner capable of doing the job. Use non-phosphate detergent, if possible, to reduce loadings at your local wastewater treatment plant.
- Limit the amount of water used in washing activities to reduce the potential of runoff carrying pollutants beyond the designated wash pad or capture system.
- Recycle wash water for subsequent washings.
- Implement one or more of the following stormwater treatment BMPs in addition to the Required BMPs:
  - Oil/water separator (Do not use an oil/water separator for washwaters containing soaps or detergents.)
  - Wet vault for settling.
  - Infiltration basin.
  - Filtration with media designed for the pollutants present.
  - Catch basin with a filter insert for pressure washing to collect suspended solids.
- Catch basin filters and/or sorbent inserts should be selected based on the type of contaminants in the stormwater.

For discharging washwaters containing soaps and detergents, the use of infiltration, biofiltration, wet ponds and wetlands must not result in the violation of groundwater quality standards.



## **A1.2 CLEANING OR WASHING OF COOKING EQUIPMENT**

**Description of Pollutant Sources:** This activity applies to businesses that clean cooking equipment such as vent filters, grills and grease traps outside of buildings.

Pollutants of concern consist of oil and grease, nutrients, suspended solids, biochemical oxygen demand (BOD) and chemical oxygen demand (COD)

**Pollutant Control Approach:** Businesses engaged in this activity that cannot connect discharges to a sanitary sewer, holding tank, or process water treatment system must contact the Department of Ecology and obtain a National Pollutant Discharge Elimination System (NPDES) wastewater permit.

### **Required BMPs**

The following BMPs or equivalent measures are required of all businesses engaged in cleaning or washing of cooking equipment:

- **Illicit connections to the storm drainage system must be eliminated. See BMP S.1 in Chapter 5 for detailed requirements.**
- **Employees must be educated about the need to prevent stormwater contamination from washing operations.**
- **Washwater cannot be discharged to the storm drainage system.**
- **Paved washing areas must be swept daily to collect loose solid materials for proper disposal.**
- **Greasy buildup on cooking equipment must be removed and properly disposed of prior to washing to reduce the amount of material that can potentially contaminate runoff.**
- **Move the activity indoors, either in an existing building or in a newly constructed building or shed, with drainage to a sanitary sewer, holding tank, or process treatment system. See BMP S.3 in Chapter 5 for further information on drainage alternatives. Any connection to the sanitary sewer requires the approval of the Tacoma Sanitary Source Control Unit at 591-5588.**

**OR**

**Use a tub or similar device to contain washwater. This water must be recycled for subsequent washing, or disposed into a holding tank or sanitary sewer.**

**OR**

**If the washing activity cannot be moved indoors or contained in a tub, then the washing area must drain to a sanitary sewer, holding tank, or process treatment system, and provisions must be made to prevent stormwater run-on onto the washing area. See BMP S.3 in Chapter 5 for detailed drainage requirements, and BMP S.7 for**

**run-on prevention schemes. If discharging to a sanitary sewer, permits must be obtained from the Tacoma Sanitary Source Control Unit at (253) 591-5588.**

- **If a holding tank is used for storage of washwater, the contents must be pumped out before it is full and disposed of appropriately to a sanitary sewer or wastewater treatment system.**

#### **Recommended BMPs**

The following BMPs are not required, but they can provide additional pollution protection:

- A cover should be placed over a designated wash area to keep rain from falling on dirty equipment and producing contaminated runoff.
- Implement one or more of the following treatment BMPs in addition to the required BMPs:
  - Oil/water separator.
  - Wet vault for settling.
  - Infiltration basin with pretreatment.
  - Filtration with media designed for the pollutants present.

For discharging washwaters containing soaps and detergents, the use of infiltration, biofiltration, wet ponds and wetlands must not result in the violation of groundwater quality standards.

### **A1.3 WASHING, PRESSURE WASHING AND STEAM CLEANING OF VEHICLES/EQUIPMENT/BUILDING STRUCTURES**

**Description of Pollutant Sources:** Vehicles, aircraft, vessels, carpet cleaning, and industrial equipment, and large buildings may be commercially cleaned with low or high pressure water or steam. This includes frequent “charity” car washes at gas stations and commercial parking lots. The cleaning can include hand washing, scrubbing, sanding, etc. Washwater from cleaning activities can contain oil and grease, suspended solids, heavy metals, soluble organics, soaps, and detergents that can contaminate stormwater.

**Pollutant Control Approach:** The preferred approach is to cover and/or contain the cleaning activity, or conduct the activity inside a building, to separate the uncontaminated stormwater from the pollutant sources. Washwater must be conveyed to a sanitary sewer after approval by the City of Tacoma, temporarily stored before proper disposal, or recycled, with no discharge to the ground, to a storm drain, or to surface water. Washwater may be discharged to the ground after proper treatment in accordance with *Ecology guidance WQ-R-95-56, “Vehicle and Equipment Washwater Discharges,” June 1995*. The quality of any discharge to the ground after proper treatment must comply with Ecology’s Ground Water Quality Standards, Chapter 173-200 WAC. Contact the local Ecology Regional Office for an NPDES Permit application for discharge of washwater to surface water or to a storm drain after on-site treatment.

#### **Required BMPs:**

##### **Conduct vehicle/equipment washing in one of the following locations:**

- **At a commercial washing facility in which the washing occurs in an enclosure and drains to the sanitary sewer, or**
- **In a building constructed specifically for washing of vehicles and equipment, which drains to a sanitary sewer.**

##### **Conduct outside washing operation in a designated wash area with the following features:**

- **In a paved area, constructed as a spill containment pad to prevent the run-on of stormwater from adjacent areas. Slope the spill containment area so that washwater is collected in a containment pad drain system with perimeter drains, trench drains or catchment drains. Size the containment pad to extend out a minimum of four feet on all sides of the vehicles and/or equipment being washed.**
- **Convey the washwater to a sump (like a grit separator) and then to a sanitary sewer (if allowed by the City of Tacoma), or other appropriate wastewater treatment or recycle system. An NPDES permit may be required for any washwater discharge to a storm drain or receiving water after treatment. Contact the Ecology regional office for NPDES Permit requirements.**
- **The containment sump must have a positive control outlet valve for spill control with live containment volume, and oil/water separation. Size the minimum live storage volume to contain the maximum expected daily washwater flow plus the sludge storage volume below the outlet pipe. The outlet valve will be shut**

*Note that the purpose of the valve is to convey only washwater and contaminated stormwater to a treatment system.*

during the washing cycle to collect the washwater in the sump. The valve should remain shut for at least two hours following the washing operation to allow the oil and solids to separate before discharge to a sanitary sewer. (See Ecology Publication WQ-R-95-56)

- The inlet valve in the discharge pipe should be closed when washing is not occurring, thereby preventing the entry of uncontaminated stormwater into the pretreatment/treatment system. The stormwater can then drain into the conveyance/discharge system outside of the wash pad (essentially bypasses the washwater treatment/conveyance system). Post signs to inform people of the operation and purpose of the valve. Clean the concrete pad thoroughly until there is no foam or visible sheen in the washwater prior to closing the inlet valve and allowing uncontaminated stormwater to overflow and drain off the pad (see Figure 4.1).
- Collect the washwater from building structures and convey it to appropriate treatment such as a sanitary sewer system if it contains oils, soaps, or detergents, where feasible. If the washwater does not contain oils, soaps, or detergents then it could drain to soils that have sufficient natural attenuation capacity for dust and sediment.

#### **Recommended Additional BMPs:**

- The wash area should be well marked at gas stations, multi-family residences and any other business where non-employees wash vehicles.
- For uncovered wash pads, the positive control outlet valve may be manually operated, but a pneumatic or electric valve system is preferable. The valve may be on a timer circuit where it is opened upon completion of a wash cycle. The timer would then close the valve after the sump or separator is drained (Figure 4.1).
- Use phosphate-free biodegradable detergents when practicable.
- Consider recycling the washwater.
- Because soluble/emulsifiable detergents can be used in the wash medium, the selection of soaps and detergents and treatment BMPs should be considered carefully. Oil/water separators are ineffective in removing emulsified or water soluble detergents.

#### **Exceptions**

- At commercial parking lots, where it is not possible to discharge the washwater to a sanitary sewer, a temporary plug or a temporary sump pump can be used at the storm drain to collect the washwater for off-site disposal such as to a nearby sanitary sewer.
- Charity car washes are not allowed to discharge dirty wash water to the storm drain. Prior to holding a charity car wash, contact the City of Tacoma for information about proper car washing procedures and to find out about utilizing a Clean Bay Car Wash loaner kit.
- New and used car dealerships may wash vehicles in the parking stalls as long as a temporary plug system is used to collect the washwater for disposal as stated above, or an approved treatment system for the washwater is in place.

At industrial sites contact the local Ecology Regional Office for NPDES Permit requirements even if soaps, detergents, and/or other chemical cleaners are not used in washing trucks.

## A1.4 COLLECTION AND DISPOSAL OF WASTEWATER IN MOBILE INTERIOR WASHING OPERATIONS

**Description of Pollutant Sources:** This activity applies to businesses that wash carpets and other interior items on a mobile site-to-site basis. The typical fleet washing process includes use of machines that spray the washwater solution onto the carpet or upholstery and then suck the dirty solution up into a portable tank with limited capacity.

Pollutants of concern consist of nutrients, suspended solids, organic compounds (such as pesticides and chemicals used for flea and odor control), biochemical oxygen demand (BOD), and chemical oxygen demand (COD).

**Pollutant Control Approach:** Common practice in the past was to discharge the dirty solution onto the ground or to a drain connected to the storm drainage system between site visits. ***These practices are now illegal. Wastewater must be poured into a sanitary sewer drain at the site of collection, the business office, or at another proper location. If sanitary sewer disposal is not available or not allowed, the collected wastewater must be returned to the business site for process treatment or transfer to a holding tank.***

### Required BMPs

This BMP is required of all businesses doing mobile interior wash activities:

- **Absolutely no wastewater from mobile interior wash activities can be disposed of outdoors, or to a drain connected to the storm drainage system. This point must be made clear to all employees. Wastewater from mobile washing operations may be permitted for sanitary sewer disposal if it does not contain high concentrations of toxic materials. Some of the chemicals used for flea and odor control are listed by EPA as toxics. The Tacoma Sanitary Source Control Unit at 591-5588 will need to know the type of chemicals and amount of water you intend to discharge. If the discharge is approved, they will then issue a permit for your activity. Wastewater must be poured into a sanitary sewer drain at the site of collection, the business office, or at another proper location.**

**If sanitary sewer disposal is not available or not allowed, the collected wastewater must be returned to the business site for process treatment or transfer to a holding tank. See BMP S.3 in Chapter 5 for details on these drainage/disposal alternatives.**

### Recommended BMPs

The following BMPs are not required, but can provide additional pollution protection:

- Use the least toxic detergents and cleaners that will get the job done. Select non-phosphate detergents when possible.
- Limit the amount of water used in interior washing operations. This will save you time, money and effort when it comes to proper disposal.
- Recycle washwater for more than one use.

**SECTION A2**  
**TRANSFER OF LIQUID OR SOLID MATERIALS**

## **A2.1 LOADING AND UNLOADING AREAS FOR LIQUID OR SOLID MATERIAL**

**Description of Pollutant Sources:** Loading/unloading of liquid and solid materials at industrial and commercial facilities are typically conducted at shipping and receiving, outside storage, fueling areas, etc. Materials transferred can include products, raw materials, intermediate products, waste materials, fuels, scrap metals, etc. Leaks and spills of fuels, oils, powders, organics, heavy metals, salts, acids, alkalis, etc. during transfer are potential causes of stormwater contamination. Spills from hydraulic line breaks are a common problem at loading docks.

**Pollutant Control Approach:** Cover and contain the loading/ unloading area where necessary to prevent run-on of stormwater and runoff of contaminated stormwater.

### **Required BMPs**

#### ***At All Loading/ Unloading Areas:***

- **A significant amount of debris can accumulate at outside, uncovered loading/unloading areas. Sweep these surfaces frequently to remove material that could otherwise be washed off by stormwater. Sweep outside areas that are covered for a period of time by containers, logs, or other material after the areas are cleared.**
- **Place drip pans, or other appropriate temporary containment device, at locations where leaks or spills may occur such as hose connections, hose reels and filler nozzles. Drip pans shall always be used when making and breaking connections (see Figure 4.2). Check loading/ unloading equipment such as valves, pumps, flanges, and connections regularly for leaks and repair as needed.**

#### **At Tanker Truck and Rail Transfer Areas to Above/Below-ground Storage Tanks:**

- **To minimize the risk of accidental spillage, prepare an "Operations Plan" that describes procedures for loading/unloading. Train the employees, especially fork lift operators, in its execution and post it or otherwise have it readily available to employees.**
- **Report spills of reportable quantities to Ecology (refer to Chapter 7 for telephone numbers of Ecology Regional Offices).**
- **Prepare and implement an Emergency Spill Cleanup Plan for the facility (BMP Spills of Oil and Hazardous Substances) which includes the following BMPs:**
  - **Ensure the clean up of liquid/solid spills in the loading/ unloading area immediately, if a significant spill occurs, and, upon completion of the loading/unloading activity, or, at the end of the working day.**
  - **Retain and maintain an appropriate oil spill cleanup kit on-site for rapid cleanup of material spills. (See BMP A7.14 Spills of Oil and Hazardous Substances).**
  - **Ensure that an employee trained in spill containment and cleanup is present during loading/unloading.**

#### **At Rail Transfer Areas to Above/below-ground Storage Tanks:**

- Install a drip pan system as illustrated (see Figure 4.3) within the rails to collect spills/leaks from tank cars and hose connections, hose reels, and filler nozzles.

#### **Loading/Unloading from/to Marine Vessels:**

- Facilities and procedures for the loading or unloading of petroleum products must comply with Coast Guard requirements.

#### **Transfer of Small Quantities from Tanks and Containers:**

- Refer to BMPs A4.8 Storage of Liquids in Permanent Above-Ground Tanks, and A4.7 Storage of Liquid, Food Waste, or Dangerous Waste Containers, for requirements on the transfer of small quantities from tanks and containers, respectively.

#### **At All Loading/ Unloading Areas:**

- Consistent with Uniform Fire Code requirements and to the extent practicable, conduct unloading or loading of solids and liquids in a manufacturing building, under a roof, or lean-to, or other appropriate cover.
- Berm, dike, and/or slope the loading/unloading area to prevent run-on of stormwater and to prevent the runoff or loss of any spilled material from the area.
- Large loading areas frequently are not curbed along the shoreline. As a result, stormwater passes directly off the paved surface into surface water. Place curbs along the edge, or slope the edge such that the stormwater can flow to an internal storm drain system that leads to an approved treatment BMP.
- Pave and slope loading/unloading areas to prevent the pooling of water. The use of catch basins and drain lines within the interior of the paved area must be minimized as they will frequently be covered by material, or they should be placed in designated “alleyways” that are not covered by material, containers or equipment.

#### **Recommended BMPs:**

- For the transfer of pollutant liquids in areas that cannot contain a catastrophic spill, install an automatic shutoff system in case of unanticipated off-loading interruption (e.g. coupling break, hose rupture, overfill, etc.).

#### **At Loading and Unloading Docks:**

- Install/maintain overhangs, or door skirts that enclose the trailer end (see Figures 4.4 and 4.5) to prevent contact with rainwater.
- Design the loading/unloading area with berms, sloping, etc. to prevent the run-on of stormwater.



- Retain on-site the necessary materials for rapid cleanup of spills.

**At Tanker Truck Transfer Areas to Above/Below-Ground Storage Tanks:**

- Pave the area on which the transfer takes place. If any transferred liquid, such as gasoline, is reactive with asphalt pave the area with Portland cement concrete.
- Slope, berm, or dike the transfer area to a dead-end sump, spill containment sump, a spill control (SC) oil/water separator, or other spill control device. The minimum spill retention time should be 15 minutes at the greater flow rate of the highest fuel dispenser nozzle through-put rate, or the peak flow rate of the 6-month, 24-hour storm event over the surface of the containment pad, whichever is greater. The volume of the spill containment sump should be a minimum of 50 gallons with an adequate grit sedimentation volume.

## **A2.2 FUELING AT DEDICATED STATIONS**

**Description of Pollutant Sources:** A fueling station is a facility dedicated to the transfer of fuels from a stationary pumping station to mobile vehicles or equipment. It includes above or underground fuel storage facilities. In addition to general service gas stations, fueling may also occur at 24-hour convenience stores, construction sites, warehouses, car washes, manufacturing establishments, port facilities, and businesses with fleet vehicles. Typically, stormwater contamination at fueling stations is caused by leaks/spills of fuels, lube oils, radiator coolants, and vehicle washwater.

**Pollutant Control Approach:** Fueling stations must be constructed on an impervious concrete pad under a roof to keep out rainfall and stormwater run-on. A treatment BMP must be used for contaminated stormwater and wastewaters in the fueling containment area.

**For new or substantially remodeled Fueling Stations:**

**Required BMPs:**

- **Prepare an emergency spill response and cleanup plan (per BMP A7.14 Spills of Oil and Hazardous Substances) and have designated trained person(s) available either on site or on call at all times to promptly and properly implement that plan and immediately cleanup all spills. Keep suitable cleanup materials, such as dry adsorbent materials, on site to allow prompt cleanup of a spill.**
- **Train employees on the proper use of fuel dispensers. Post signs in accordance with the Uniform Fire Code (UFC). Post “No Topping Off” signs (topping off gas tanks causes spillage and vents gas fumes to the air). Make sure that the automatic shutoff on the fuel nozzle is functioning properly.**
- **The person conducting the fuel transfer must be present at the fueling pump during fuel transfer, particularly at unattended or self-serve stations.**
- **Keep drained oil filters in a suitable container or drum.**
- **Design the fueling island to control spills (dead-end sump or spill control separator in compliance with the UFC), and to treat collected stormwater and/or wastewater to required levels. Slope the concrete containment pad around the fueling island toward drains; either trench drains, catch basins and/or a dead-end sump. The slope of the drains shall not be less than 1 percent (Section 7901.8 of the UFC). Drains to treatment shall have a shutoff valve, which must be closed in the event of a spill. The spill control sump must be sized in compliance with Section 7901.8 of the UFC; or**
- **Design the fueling island as a spill containment pad with a sill or berm raised to a minimum of four inches (Section 7901.8 of the UFC) to prevent the runoff of spilled liquids and to prevent run-on of stormwater from the surrounding area. Raised sills are not required at the open-grate trenches that connect to an approved drainage-control system.**
- **The fueling pad must be paved with Portland cement concrete, or equivalent. Asphalt is not considered an equivalent material.**

- The fueling island must have a roof or canopy to prevent the direct entry of precipitation onto the spill containment pad (see Figure 4.6). The roof or canopy should, at a minimum, cover the spill containment pad (within the grade break or fuel dispensing area) and preferably extend several additional feet to reduce the introduction of windblown rain. Convey all roof drains to storm drains outside the fueling containment area.
- Stormwater collected on the fuel island containment pad must be conveyed to a sanitary sewer system, if approved by the City of Tacoma; or to an approved treatment system such as an oil/water separator and a basic treatment BMP. (Basic treatment BMPs are listed in Volume V and include media filters and biofilters) Discharges from treatment systems to storm drains or surface water or to the ground must not display ongoing or recurring visible sheen and must not contain greater than a significant amount of oil and grease.
- Alternatively, stormwater collected on the fuel island containment pad may be collected and held for proper off site disposal.
- Conveyance of any fuel-contaminated stormwater to a sanitary sewer must be approved by the City of Tacoma and must comply with pretreatment regulations (WAC 173-216-060). These regulations prohibit discharges that could cause fire or explosion. An explosive or flammable mixture is defined under state and federal pretreatment regulations, based on a flash point determination of the mixture. If contaminated stormwater is determined not to be explosive, then it could be conveyed to a sanitary sewer system.
- Transfer the fuel from the delivery tank trucks to the fuel storage tank in impervious contained areas and ensure that appropriate overflow protection is used. Alternatively, cover nearby storm drains during the filling process and use drip pans under all hose connections.

**Additional BMP for Vehicles 10 feet in height or greater:**

A roof or canopy may not be practicable at fueling stations that regularly fuel vehicles that are 10 feet in height or greater, particularly at industrial or WSDOT sites. At those types of fueling facilities, the following BMPs apply, as well as all of the other required BMPs and fire prevention (UFC) requirements.

- If a roof or canopy is impractical the concrete fueling pad must be equipped with emergency spill control, which includes a shutoff valve for the drainage from the fueling area. The valve must be closed in the event of a spill. An electronically actuated valve is preferred to minimize the time lapse between spill and containment. Spills must be cleaned up and disposed off-site in accordance with BMP A7.14 Spills of Oil and Hazardous Substances.
- The valve may be opened to convey contaminated stormwater to a sanitary sewer, if approved by the City of Tacoma, or to oil removal treatment such as an API or CP oil/water separator, catch basin insert, or equivalent treatment, and then to a basic treatment BMP. Discharges from treatment systems to storm drains or surface water

**or to the ground must not display ongoing or recurring visible sheen and must not contain greater than a significant amount of oil and grease.**

**An explosive or flammable mixture is defined under state and federal pretreatment regulations, based on a flash point determination of the mixture. If contaminated stormwater is determined not to be explosive or flammable then it could be conveyed to a sanitary sewer system.**

## **A2.3 ENGINE REPAIR AND MAINTENANCE**

**Description of Pollutant Sources:** This activity applies to businesses and public agencies where fuel filters, engine oil and other fluids such as battery acid, coolants and transmission and brake fluids are removed and replaced in vehicles and equipment. It also applies to mobile vehicle maintenance operations, such as at construction sites. Related vehicle maintenance activities are covered under the following activity headings in this manual:

- A1.3 Washing, Pressure Washing and Steam Cleaning of Vehicles/Equipment/Building Structures**
- A2.2 Fueling at Dedicated Stations**
- A3.4 Painting, Finishing and Coating of Vehicles, Products and Equipment**
- A7.3 Vehicle and Equipment Parking and Storage**

Pollutants of concern include toxic hydrocarbons, toxic organic compounds, oils and greases, pH and heavy metals.

**Pollutant Control Approach:** Control of leaks and spills of fluids using good housekeeping and cover and containment BMPs.

### **Required BMPs**

The following BMPs or equivalent measures are required of all businesses and agencies engaged in engine and vehicle repair:

- **Employees must be educated about the need for careful handling of automotive fluids. Employees at businesses or agencies who routinely change or handle these fluids must be trained in spill response and cleanup procedures.**
- **Spill cleanup materials, such as rags and absorbent materials, must always be kept close at hand when changing oil and other fluids. You can comply more easily with sewer and stormwater requirements by running a 'dry shop', thereby reducing your consumption/discharge of liquids. Soiled rags and other cleanup material must be properly disposed of or cleaned and reused.**
- **No drains inside maintenance buildings may connect to either the sanitary sewer or the storm drainage system without prior approval.**
- **Do not hose down the maintenance/repair area. Instead, sweep the area weekly to collect dirt, and wipe up spills with rags and other absorbent materials.**
- **If the work is done at a mobile location, such as a construction site, a tarp, ground cloth or drip pans must be used beneath the vehicle or equipment to capture all spills and drips. The collected drips and spills must be recycled or disposed of properly. See BMP S.2 in Chapter 5 for disposal options.**
- **If this activity occurs at a stationary business location, the activity area must be moved indoors. An exception to this requirement would be equipment that is too large to fit under a roofed area. In this case, the outdoor area must be paved, provided with a sump drain and provision made for stormwater run-on prevention. See BMP S.6 and S.7 in Chapter 5 for more on paving, sump drains and holding tanks,**

and run-on prevention. Contact the Tacoma Sanitary Source Control unit at 591-5588 for information on requirements for disposal to sewer. If you are on a septic tank, sump contents will need to be pumped and disposed of by an oil recycler or hazardous waste company.

- Recycle oil, antifreeze, batteries, and air conditioning coolant.
- Implement the following treatment BMP in addition to the Required BMPs:
  - An oil/water separator or other appropriate treatment, if soluble components are present, should be used to treat all runoff from the fluid changing area.

### **Recommended BMPs**

The following BMPs are not required, but can provide additional pollution prevention.

- Drain all fluids, from wrecked vehicles and 'parts' cars/equipment upon arrival. Recover air conditioning gases.
- Use reusable cloth rags to clean up drips and small spills instead of disposables: these can be professionally laundered and reused. Do not attempt to launder these at home or at a coin-op laundry.
- Use absorbent pillows or booms in or around storm drains and catch basins to absorb oil and fuel.

## **A2.4 MOBILE FUELING OF VEHICLES AND HEAVY EQUIPMENT**

**Description of Pollutant Sources:** Mobile fueling, also known as fleet fueling, wet fueling, or wet hosing, is the practice of filling fuel tanks of vehicles by tank trucks that are driven to the yards or sites where the vehicles to be fueled are located. Mobile fueling is only conducted using diesel fuel, as mobile fueling of gasoline is prohibited. Diesel fuel is considered as a Class II Combustible Liquid, whereas gasoline is considered as a Flammable Liquid.

Historically mobile fueling has been conducted for off-road vehicles that are operated for extended periods of time in remote areas. This includes construction sites, logging operations, and farms. Mobile fueling of on-road vehicles is also conducted commercially in the State of Washington.

**Pollutant Control Approach:** Proper training of the fueling operator, and the use of spill/drip control and reliable fuel transfer equipment with backup shutoff valving are typically needed.

### **Required BMPs**

**Organizations and individuals conducting mobile fueling operations must implement the following BMPs.**

**The operating procedures for the driver/operator should be simple, clear, effective and their implementation verified by the organization that will potentially be liable for environmental and third party damage.**

- **Ensure that all mobile fueling operations are approved by the Tacoma Fire Department and comply with local and Washington State fire codes.**
- **In fueling locations that are in close proximity to sensitive aquifers, designated wetlands, wetland buffers, or other waters of the State, approval by the City of Tacoma is necessary to ensure compliance with additional local requirements.**
- **Ensure the compliance with all 49 CFR 178 requirements for DOT 406 cargo tanker. Documentation from a Department of Transportation (DOT) Registered Inspector shall be proof of compliance.**
- **Ensure the presence and the constant observation/monitoring of the driver/operator at the fuel transfer location at all times during fuel transfer and ensure that the following procedures are implemented at the fuel transfer locations:**
  - **Locating the point of fueling at least 25 feet from the nearest storm drain or inside an impervious containment with a volumetric holding capacity equal to or greater than 110 percent of the fueling tank volume, or covering the storm drain to ensure no inflow of spilled or leaked fuel. Storm drains that convey the inflow to a spill control separator approved by the City of Tacoma, including the Tacoma Fire Department need not be covered. Potential spill/leak conveyance surfaces must be impervious and in good repair.**

- Placement of a drip pan, or an absorbent pad under each fueling location prior to and during all dispensing operations. The pan (must be liquid tight) and the absorbent pad must have a capacity of 5 gallons. Spills retained in the drip pan or the pad need not be reported.
- The handling and operation of fuel transfer hoses and nozzle, drip pan(s), and absorbent pads as needed to prevent spills/leaks of fuel from reaching the ground, storm drains, and receiving waters.
- Not extending the fueling hoses across a traffic lane without fluorescent traffic cones, or equivalent devices, conspicuously placed so that all traffic is blocked from crossing the fuel hose.
- Removing the fill nozzle and cessation of filling when the automatic shut-off valve engages. Do not allow automatic shutoff fueling nozzles to be locked in the open position.
- Not “topping off” the fuel receiving equipment
- Provide the driver/operator of the fueling vehicle with:
  - Adequate flashlights or other mobile lighting to view fill openings with poor accessibility. Consult with the Tacoma Fire Department for additional lighting requirements.
  - Two-way communication with his/her home base.
- Train the driver/operator annually in spill prevention and cleanup measures and emergency procedures. Make all employees aware of the significant liability associated with fuel spills.
- The fueling operating procedures should be properly signed and dated by the responsible manager, distributed to the operators, retained in the organization files, and made available in the event an authorized government agency requests a review.
- Ensure that the Tacoma Fire Department (911) and the appropriate regional office of the Department of Ecology are immediately notified in the event of any spill entering the surface or ground waters. Establish a “call down list” to ensure the rapid and proper notification of management and government officials should any significant amount of product be lost off-site. Keep the list in a protected but readily accessible location in the mobile fueling truck. The “call down list” should also pre-identify spill response contractors available in the area to ensure the rapid removal of significant product spillage into the environment.
- Maintain a minimum of the following spill clean-up materials in all fueling vehicles, that are readily available for use:
  - Non-water absorbents capable of absorbing 15 gallons of diesel fuel;
  - A storm drain plug or cover kit;



- **A non-water absorbent containment boom of a minimum 10 feet in length with a 12-gallon absorbent capacity;**
- **A non-metallic shovel; and,**
- **Two, five-gallon buckets with lids.**
  
- **Use automatic shutoff nozzles for dispensing the fuel. Replace automatic shut-off nozzles as recommended by the manufacturer.**
- **Maintain and replace equipment on fueling vehicles, particularly hoses and nozzles, at established intervals to prevent failures.**
- **Automatic fuel transfer shut-off nozzles; and,**
- **An adequate lighting system at the filling point.**

**SECTION A3**  
**PRODUCTION AND APPLICATION ACTIVITIES**

### **A3.1 CONCRETE AND ASPHALT MIXING AND PRODUCTION AT STATIONARY SITES**

**Description of Pollutant Sources:** This activity applies to businesses and agencies that mix raw materials onsite to produce concrete or asphalt. It also applies to subsequent uses such as pouring concrete structures and making other concrete or asphalt products. Mobile concrete pouring and asphalt application are covered under **Activity A3.2** in this section. Requirements for stockpiling of raw materials are covered under **Activity A4.1 Storage or Transfer (outside) of solid raw materials, by-products or finished products.**

Pollutants of concern include toxic hydrocarbons, toxic organic compounds, oils and greases, heavy metals and pH.

**Pollutant Control Approach:** Cover and contain processes where possible and prevent stormwater run-on and contamination, where feasible.

Any facility categorized under SIC Code 2951 or SIC Code 3273 may need to comply with Ecology's Sand and Gravel General Permit. Contact Ecology at (360) 407-6400 for additional information.

#### **Required BMPs**

**The following BMPs or equivalent measures are required of all businesses and public agencies active in concrete and asphalt mixing and production:**

- **Eliminate all illicit connections to the storm drainage system. See BMP S.1 in Chapter 5 for a detailed discussion on identifying and eliminating these connections.**
- **All process water from production, pouring and equipment cleaning must be discharged to a dead-end sump, process water treatment system or sanitary sewer, or recycled. Never wash fresh concrete or concrete mixer washout into streets, storm drainage systems, streams or other water bodies.**
- **A BMP maintenance schedule must be established, and employees educated about the need to prevent stormwater contamination through the use and proper maintenance of BMPs.**
- **Production and pouring areas must be protected from stormwater run-on. See BMP S.7 in Chapter 5 for methods of run-on protection.**
- **Cover the production area for prevention of stormwater run-on. See BMP S.4 and S.7 for information on covers and run-on prevention.**
- **Use absorbent materials or catch basin filters in and around storm drains and catch basins to filter out contaminants. See Volume V of this Manual, Runoff Treatment BMPs for more information about absorbent materials and catch basin filters.**

## Recommended BMPs

The following BMPs are not required, but can provide additional pollution protection:

- The production and pouring area should be swept at the end of each work day to collect loose chunks of aggregate and raw materials for recycling or proper disposal. See BMP S.2 in Chapter 5 for disposal options.
- Sweep all driveways and gutters that show accumulation of materials to minimize the amount that could be carried offsite by rain and enter the storm drainage system.
- Asphalt plants should use an oil/water separator to treat stormwater runoff. See Volume V of this Manual, Runoff Treatment BMPs for more information.
- Pave the mixing, production and pouring areas. A sump drain in these areas is probably not advisable due to potential clogging problems, but could be used in a curing area. Sweep these areas to remove loose aggregate and recycle or dispose of properly.
- Use storm drain covers or similarly effective containment devices to prevent runoff from entering the storm drainage system. Accumulations of dirty runoff must be disposed of properly.

Contact the City Surface Water Source Control Unit at 253-591-5588 for information about water quality treatment BMPs for these types of operations. Contact the Department of Ecology's web page for accepted water quality treatment at <http://www.ecy.wa.gov/programs/wq/stormwater/index.html>.

The use of any treatment BMP must not result in the violation of groundwater, surface water, or drinking water standards.

## **A3.2 CONCRETE POURING, CONCRETE CUTTING, AND ASPHALT APPLICATION AT TEMPORARY SITES**

**Description of Pollutant Sources:** This activity applies to businesses and public agencies that apply asphalt or pour or cut concrete for building construction and remodeling, road construction, sidewalk, curb and gutter repairs and construction, sealing of driveways and roofs, and other applications. These activities are typically done on a temporary site-to-site basis where permanent BMP measures do not apply. Concrete pouring activities can not only severely alter the pH of receiving waters, but slurry from aggregate washing can harden in storm pipes, thus reducing capacity and creating flooding problems.

Pollutants of concern include toxic hydrocarbons, toxic organic compounds, oils and greases, heavy metals, suspended solids and pH.

**Pollutant Control Approach:** Train employees on proper procedures, sweep or shovel aggregate chunks, collect accumulated runoff and solids, and wash equipment in designated areas.

### **Required BMPs**

**The following BMPs or equivalent measures are required of all businesses and agencies doing concrete pouring and asphalt application at temporary sites:**

- **Employees must be educated on the pollution hazards of concrete and asphalt application and cutting.**
- **Loose aggregate chunks and dust must be swept or shoveled and collected (not hosed down a storm drain) for recycling or proper disposal at the end of each work day, especially at work sites such as streets, driveways, parking lots, sidewalks, curbs and gutters where rain can readily pick up the loose material and carry it to the nearest stormwater conveyance. Small amounts of excess concrete, grout and mortar can be disposed of in the trash.**
- **Storm drain covers or similarly effective containment devices must be placed over all nearby drains at the beginning of each day. Shovel or vacuum slurry and remove from the site. All accumulated runoff and solids must be collected and properly disposed (see BMP S.2 in Chapter 5 for disposal options) at the end of each work day, or more often if necessary.**
- **Exposed aggregate washing, where the top layer of unhardened concrete is hosed or scraped off to leave a rough finish, must be done with a mechanism for containment and collection of the discarded concrete slurry (such as the storm drain covers mentioned above). The easiest way to contain the washwater will be to direct the washings to a hole in the ground where the water can percolate into the ground and the solids later covered with soil.**
- **If directed to a drain, a catch basin filter insert must be used to remove the solids. This is especially useful if the activity must proceed on rainy days. See Volume V of this Manual, Runoff Treatment BMPs for more information about catch basin filter inserts.**

- **Cleaning of concrete application and mixing equipment or concrete vehicles on the work site must be done in a designated area where the rinse water is controlled. The rinse water must either be collected for proper disposal or put into a hole in the ground where the water can percolate away and the solids later covered with soil or recovered and disposed or recycled.**

**The use of any treatment BMP must not result in the violation of groundwater, surface water, or drinking water quality standards.**

### **Recommended BMPs**

The following BMPs are not required but can provide additional pollution prevention:

- Avoid the activity when rain is occurring or expected.
- If possible, portable asphalt mixing equipment should be covered by an awning, a lean-to or other simple structure to avoid contact with rain. See BMP S.4 in Chapter 5 for further details on cover structures.
- Recycle broken concrete and asphalt. Look under Recycling Services in the Yellow pages of the phone book to find the recycler nearest you.

### **A3.3 MANUFACTURING AND POST-PROCESSING OF METAL PRODUCTS**

**Description of Pollutant Sources:** This activity applies to businesses such as mills, foundries, and fabricators that manufacture or post-process metal products. A variety of activities such as machining, grinding, soldering, cutting, welding, quenching, cooling and rinsing may take place. These businesses may be required to obtain a National Pollutant Discharge Elimination System (NPDES) permit from the Department of Ecology. See Chapter 6 for a discussion of NPDES requirements. Note: Painting, finishing and coating of metal products is covered under **A3.10 Painting, Finishing and Coating of Vehicles, Boats, Buildings and Equipment**.

Pollutants of concern include toxic organic compounds, heavy metals, oils and greases, pH, suspended solids, and chemical oxygen demand (COD).

**Pollutant Control Approach:** Cover and contain operations and apply good housekeeping and preventive maintenance practices to prevent the contamination of stormwater.

#### **Required BMPs**

The following BMPs or equivalent measures are required of all businesses engaged in metals manufacturing or post-processing:

- **Eliminate illicit connections to the storm drainage system. See BMP S.1 in Chapter 5 for detailed information on identifying and eliminating illicit connections.**
- **Process wastewater (including contact cooling water, filter backwash, cooling tower blowdown, etc.) from this activity, and stormwater runoff from activity areas, must discharge to a sanitary sewer, holding tank, or process treatment system that would need an Ecology NPDES Permit for discharge to surface water or storm drain. Contact the Tacoma Sanitary Source Control Unit at 591-5588 to obtain permits for discharge to the sewer. See BMP S.3 in Chapter 5 for detailed requirements.**
- **Employees must be educated to control their work with metal products to minimize pollution.**
- **The activity area must be swept at the end of each work day to collect and dispose of metal fragments and product residues properly. See BMP S.2 in Chapter 5 for disposal alternatives.**

#### **Recommended BMPs**

The following BMPs are not required but can provide additional pollution protection:

- **Limit the amount of water used in quenching and rinsing. Recycle used water where possible.**
- **Cover the activity area to prevent rain from contacting the process, and to reduce the amount of runoff that has to be detained or treated.**

- Use a catch basin filter insert to capture stray metal particles. A catch basin filter may help remove dissolved metals. See Volume V of this Manual, Runoff Treatment BMPs for more information on catch basin filter inserts.
- Implement a program to track purchase and consumption of lubricants, solvents, and additives. Check with operating managers for an explanation if consumption increases. Recommend action if significant equipment leaks or spills are identified.
- Refer to the BMPs under sections A2 Transfer of Liquid Materials and A4 Storage and Stockpiling Activities, and utilize those BMPs which are applicable for materials storage and maintenance activities in your shop.



### **A3.4 WOOD TREATMENT AREAS**

**Description of Pollutant Sources:** Wood treatment includes both anti-staining and wood preserving using pressure processes or by dipping or spraying. Wood preservatives include creosote, creosote/coal tar, pentachlorophenol, copper naphthenate, arsenic trioxide, malathion, or inorganic arsenicals such as chromated copper arsenate, acid copper chromate, chromate zinc chloride, and fluor-chrome-arsenate-phenol. Anti-staining chemical additives include iodo-propenyl-butyl carbamate, dimethyl sulfoxide, didecyl dimethyl ammonium chloride, sodium azide, 8-quinolinol; copper (II) chelate, sodium ortho-phenylphenate, 2-(thiocyanomethylthio)-benzothiazole (TCMTB) and methylene bis- (thiocyanate), and zinc naphthenate.

Pollutant sources include drips of condensate or preservative after pressurized treatment; product washwater (in the treatment or storage areas), spills and leaks from process equipment and preservative tanks, fugitive emissions from vapors in the process, blowouts and emergency pressure releases, and kick-back from lumber (phenomenon where preservative leaks as it returns to normal pressure). Potential pollutants typically include the wood treating chemicals, BOD, suspended solids, oil and grease, benzene, toluene, ethylbenzene, phenol, chlorophenols, nitrophenols, heavy metals, and PAH depending on the chemical additive used.

**Pollutant Control Approach:** Cover and contain all wood treating areas and prevent all leaching of and stormwater contamination by wood treating chemicals. All wood treating facilities in Washington State are required to be covered under an Individual NPDES Permit.

#### **Required BMPs**

The individual NPDES Permit will require at a minimum the following BMPs:

- **Dedicate equipment that is used for treatment activities to prevent the tracking of treatment chemicals to other areas on the site.**
- **Eliminate non-process traffic on the drip pad. Scrub down non-dedicated lift trucks on the drip pad.**
- **Immediately remove and properly dispose of soils with visible surface contamination (green soil) to prevent the spread of chemicals to ground water and/or surface water via stormwater runoff.**
- **If any wood is observed to be contributing chemicals to the environment in the treated wood storage area, relocate it on a concrete chemical containment structure until the surface is clean and until it is drip free and surface dry.**
- **Cover and/or enclose, and contain with impervious surfaces, all wood treatment areas. Slope and drain areas around dip tanks, spray booths, retorts, and any other process equipment in a manner that allows return of treatment chemicals to the wood treatment process.**
- **Cover storage areas for freshly treated wood to prevent contact of treated wood products with stormwater. Segregate clean stormwater from process water. Ensure that all process water is conveyed to an approved treatment system.**

- Seal any holes or cracks in the asphalt areas that are subject to wood treatment chemical contamination.
- Elevate stored, treated wood products to prevent contact with stormwater run-on and runoff.
- Place dipped lumber over the dip tank, or on an inclined ramp for a minimum of 30 minutes to allow excess chemical to drip back to the dip tank.
- Place treated lumber either from dip tanks or retorts in a covered paved storage area for at least 24 hours before placement in outside storage. Use a longer storage period during cold weather unless the temporary storage building is heated. The wood shall be drip free and surface dry before it is moved outside.

#### **Recommended BMP**

- Consider using preservative chemicals that do not adversely impact receiving surface water and groundwater.

### A3.5 COMMERCIAL COMPOSTING

**Description of Pollutant Sources:** Commercial compost facilities, operating outside without cover, require large areas to decompose wastes and other feedstocks. These facilities should be designed to separate stormwater from leachate (i.e., industrial wastewater) to the greatest extent possible. When stormwater is allowed to contact any active composting areas, including waste receiving and processing areas, it becomes leachate. Pollutants in leachate include nutrients, biochemical oxygen demand (BOD), organics, coliform bacteria, acidic pH, color, and suspended solids. Stormwater at a compost facility consists of runoff from areas at the facility that are not associated with active processing and curing, such as product storage areas, vehicle maintenance areas, and access roads.

**NPDES Permit Requirements:** Discharge of leachate from a compost facility will require a State or NPDES permit from Ecology, depending on the disposal method chosen for managing leachate at the facility. (See Chapter 2 in “Compost Facility Resource Handbook, Guidance for Washington State”, November 1998, Publication # 97-502.) An additional alternative, zero discharge, is possible by containing all leachate from the facility (in tanks or ponds) or preventing production of leachate (by composting under a roof or in an enclosed building).

**Pollutant Control Approach:** Consider the leachate control specified in publication #97-502 or zero leachate discharge.

#### Required BMPs

- **Ensure that the compost feedstocks do not contain dangerous wastes, regulated under Chapter 173-303 WAC or hazardous products of a similar nature, or solid wastes that are not beneficial to the composting process. Employees must be trained to screen these materials in incoming wastes.**
- **Contact other federal and state agencies and the City of Tacoma regarding environmental or zoning authority for applicable permit and regulatory information. The Tacoma-Pierce County Health Department is responsible for issuing solid waste handling permits for commercial compost facilities.**
- **Apply for coverage under the General Permit to Discharge Stormwater Associated with Industrial Activities, if the facility discharges stormwater to surface water or a municipal stormwater system. If all stormwater from the facility infiltrates into the surrounding area, the General Permit is not required.**
- **Develop a plan of operations as outlined in the Compost Facility Resource Handbook, Publication #97-502.**
- **Store finished compost in a manner to prevent contamination of stormwater.**
- **Compost pads are required for all uncovered facilities in areas of the state with wet climates (per water quality regulations).**
- **Provide curbing for all compost pads to prevent stormwater run-on and leachate run-off.**

*Refer to “Compost Facility Resource Handbook, Guidance for Washington State,” November 1998, Publication # 97-502, for additional design criteria and information.*

- **Slope all compost pads sufficiently to direct leachate to the collection device.**
- **Provide one or more sumps or catch basins capable of collecting all leachate generated by the design storm and conveying it to the leachate holding structure for all compost pads.**
- **Convey all leachate from composting operations to a sanitary sewer, holding tank, or on-site treatment systems designed to treat the leachate and total suspended solids (TSS).**
- **Ponds used to collect, store, or treat leachate and other contaminated waters associated with the composting process must be lined to prevent ground water contamination. Apply “AKART” or All Known Available and Reasonable Methods of Prevention and Treatment to all pond liners, regardless of the construction materials.**

#### **Recommended BMPs**

- Clean up debris from yard areas regularly.
- Locate stored residues in areas designed to collect leachate.
- Limit storage times of residues to prevent degradation and generation of leachate.
- Consider using leachate as make-up water in early stages of the composting process. Since leachate can contain pathogenic bacteria, care should be taken to avoid contaminating finished product or nearly finished product with leachate.

## **A3.6 LANDSCAPING AND LAWN/VEGETATION MANAGEMENT**

**Description of Pollutant Sources:** Landscaping can include grading, soil transfer, vegetation removal, pesticide and fertilizer applications, and watering. Stormwater contaminants include toxic organic compounds, heavy metals, oils, total suspended solids, coliform bacteria, fertilizers, and pesticides.

Lawn and vegetation management can include control of objectionable weeds, insects, mold, bacteria and other pests with chemical pesticides and is conducted commercially at commercial, industrial, and residential sites. Examples include weed control on golf course lawns, access roads, and utility corridors and during landscaping; sap stain and insect control on lumber and logs; rooftop moss removal; killing nuisance rodents; fungicide application to patio decks, and residential lawn/plant care. Toxic pesticides such as pentachlorophenol, carbamates, and organometallics can be released to the environment by leaching and dripping from treated parts, container leaks, product misuse, and outside storage of pesticide contaminated materials and equipment. Poor management of the vegetation and poor application of pesticides or fertilizers can cause appreciable stormwater contamination.

**Pollutant Control Approach:** Control of fertilizer and pesticide applications, soil erosion, and site debris to prevent contamination of stormwater.

Develop and implement an Integrated Pest Management Plan (IPM) and use pesticides only as a last resort. Refer to Appendix IV-B Example of an Integrated Best Management Program for more information. If pesticides/herbicides are used they must be carefully applied in accordance with label instructions on U.S. Environmental Protection Agency (EPA) registered materials. Maintain appropriate vegetation, with proper fertilizer application where practicable, to control erosion and the discharge of stormwater pollutants. Where practicable grow plant species appropriate for the site, or adjust the soil properties of the subject site to grow desired plant species.

### **Required BMPs for Landscaping**

- **Install engineered soil/landscape systems to improve the infiltration and regulation of stormwater in landscaped areas.**
- **Do not dispose of collected vegetation into waterways or storm drainage systems.**

### **Recommended BMPs for Landscaping**

- Conduct mulch-mowing whenever practicable
- Dispose of grass clippings, leaves, sticks, or other collected vegetation, by composting, if feasible.
- Use mulch or other erosion control measures when soils are exposed for more than one week during the dry season or two days during the rainy season.
- If oil or other chemicals are handled, store and maintain appropriate oil and chemical spill cleanup materials in readily accessible locations. Ensure that employees are familiar with proper spill cleanup procedures.

- Till fertilizers into the soil rather than dumping or broadcasting onto the surface. Determine the proper fertilizer application for the types of soil and vegetation encountered.
- Till a topsoil mix or composted organic material into the soil to create a well-mixed transition layer that encourages deeper root systems and drought-resistant plants.
- Use manual and/or mechanical methods of vegetation removal rather than applying herbicides, where practical.

#### **Required BMPs for the Use of Pesticides**

- **Develop and implement an integrated pest management system (IPM) (See section on IPM at end of BMP) and use pesticides only as a last resort.**
- **Implement a pesticide-use plan and include at a minimum: a list of selected pesticides and their specific uses; brands, formulations, application methods and quantities to be used; equipment use and maintenance procedures; safety, storage, and disposal methods; and monitoring, record keeping, and public notice procedures. All procedures shall conform to the requirements of Chapter 17.21 RCW and Chapter 16-228 WAC (Appendix IV-D R.7).**
- **Choose the least toxic pesticide available that is capable of reducing the infestation to acceptable levels. The pesticide should readily degrade in the environment and/or have properties that strongly bind it to the soil. Any pest control used should be conducted at the life stage when the pest is most vulnerable. For example, if it is necessary to use a *Bacillus thuringiensis* application to control tent caterpillars, it must be applied before the caterpillars cocoon or it will be ineffective. Any method used should be site-specific and not used wholesale over a wide area.**
- **Apply the pesticide according to label directions. Under no conditions shall pesticides be applied in quantities that exceed manufacturer's instructions.**
- **Mix the pesticides and clean the application equipment in an area where accidental spills will not enter surface or ground waters, and will not contaminate the soil.**
- **Store pesticides in enclosed areas or in covered impervious containment. Ensure that pesticide contaminated stormwater or spills/leaks of pesticides are not discharged to storm drains. Do not hose down the paved areas to a storm drain or conveyance ditch. Store and maintain appropriate spill cleanup materials in a location known to all near the storage area.**
- **Clean up any spilled pesticides and ensure that the pesticide contaminated waste materials are kept in designated covered and contained areas.**
- **The pesticide application equipment must be capable of immediate shutoff in the event of an emergency.**

- **Do not spray pesticides within 100 feet of open waters including wetlands, ponds, and streams, sloughs and any drainage ditch or channel that leads to open water except when approved by Ecology or by the City of Tacoma. All sensitive areas including wells, creeks and wetlands must be flagged prior to spraying.**
- **As required by the City of Tacoma or by Ecology, complete public posting of the area to be sprayed prior to the application.**
- **Spray applications should only be conducted during weather conditions as specified in the label direction and applicable local and state regulations. Do not apply during rain or immediately before expected rain.**

### **Recommended BMPs for the use of Pesticides**

- Consider alternatives to the use of pesticides such as covering or harvesting weeds, substitute vegetative growth, and manual weed control/moss removal.
- Consider the use of soil amendments, such as compost, that are known to control some common diseases in plants, such as Pythium root rot, ashy stem blight, and parasitic nematodes. The following are three possible mechanisms for disease control by compost addition (USEPA Publication 530-F-9-044):
  1. Successful competition for nutrients by antibiotic production;
  2. Successful predation against pathogens by beneficial microorganism; and
  3. Activation of disease-resistant genes in plants by composts.

*Installing an amended soil/landscape system can preserve both the plant system and the soil system more effectively. This type of approach provides a soil/landscape system with adequate depth, permeability, and organic matter to sustain itself and continue working as an effective stormwater infiltration system and a sustainable nutrient cycle.*

- Once a pesticide is applied, its effectiveness should be evaluated for possible improvement. Records should be kept showing the applicability and inapplicability of the pesticides considered.
- An annual evaluation procedure should be developed including a review of the effectiveness of pesticide applications, impact on buffers and sensitive areas (including potable wells), public concerns, and recent toxicological information on pesticides used/proposed for use. If individual or public potable wells are located in the proximity of commercial pesticide applications contact the regional Ecology hydrogeologist to determine if additional pesticide application control measures are necessary.
- Rinsate from equipment cleaning and/or triple-rinsing of pesticide containers should be used as product or recycled into product.
- The application equipment used should be capable of immediate shutoff in the event of an emergency.

*For more information, contact the WSU Extension Home-Assist Program, (253) 445-4556, or Bio-Integral Resource Center (BIRC), P.O. Box 7414, Berkeley, CA.94707, or the Washington Department of Ecology to obtain "Hazardous Waste Pesticides" (Publication #89-41); and/or EPA to obtain a publication entitled "Suspended, Canceled and Restricted Pesticides" which lists all restricted pesticides and the specific uses that are allowed. Valuable information from these sources may also be available on the internet.*

## **Required BMPs for Vegetation Management**

- **Use at least an eight-inch "topsoil" layer with at least 8 percent organic matter to provide a sufficient vegetation-growing medium. Amending existing landscapes and turf systems by increasing the percent organic matter and depth of topsoil can substantially improve the permeability of the soil, the disease and drought resistance of the vegetation, and reduce fertilizer demand. This reduces the demand for fertilizers, herbicides, and pesticides. Organic matter is the least water-soluble form of nutrients that can be added to the soil. Composted organic matter generally releases only between 2 and 10 percent of its total nitrogen annually, and this release corresponds closely to the plant growth cycle. If natural plant debris and mulch are returned to the soil, this system can continue recycling nutrients indefinitely.**
- **Select the appropriate turfgrass mixture for your climate and soil type. Certain tall fescues and rye grasses resist insect attack because the symbiotic endophytic fungi found naturally in their tissues repel or kill common leaf and stem-eating lawn insects. They do not, however, repel root-feeding lawn pests such as Crane Fly larvae, and are toxic to ruminants such as cattle and sheep. The fungus causes no known adverse effects to the host plant or to humans. Endophytic grasses are commercially available and can be used in areas such as parks or golf courses where grazing does not occur. The local Cooperative Extension office can offer advice on which types of grass are best suited to the area and soil type.**
- **Use the following seeding and planting BMPs, or equivalent BMPs to obtain information on grass mixtures, temporary and permanent seeding procedures, maintenance of a recently planted area, and fertilizer application rates: Temporary Seeding, Mulching and Matting, Clear Plastic Covering, Permanent Seeding and Planting, and Sodding as described in Volume II, Construction Stormwater Pollution Prevention).**
- **Selection of desired plant species can be made by adjusting the soil properties of the subject site. For example, a constructed wetland can be designed to resist the invasion of reed canary grass by layering specific strata of organic matters (e.g., compost forest product residuals) and creating a mildly acidic pH and carbon-rich soil medium. Consult a soil restoration specialist for site-specific conditions.**
- **Aerate lawns regularly in areas of heavy use where the soil tends to become compacted. Aeration should be conducted while the grasses in the lawn are growing most vigorously. Remove layers of thatch greater than ¾-inch deep.**



- **Mowing is a stress-creating activity for turfgrass. When grass is mowed too short its productivity is decreased and there is less growth of roots and rhizomes. The turf becomes less tolerant of environmental stresses, more disease prone and more reliant on outside means such as pesticides, fertilizers and irrigation to remain healthy. Set the mowing height at the highest acceptable level and mow at times and intervals designed to minimize stress on the turf. Generally mowing only 1/3 of the grass blade height will prevent stressing the turf.**

***Irrigation:***

- **The depth from which a plant normally extracts water depends on the rooting depth of the plant. Appropriately irrigated lawn grasses normally root in the top 6 to 12 inches of soil; lawns irrigated on a daily basis often root only in the top 1 inch of soil. Improper irrigation can encourage pest problems, leach nutrients, and make a lawn completely dependent on artificial watering. The amount of water applied depends on the normal rooting depth of the turfgrass species used, the available water holding capacity of the soil, and the efficiency of the irrigation system. Consult with Tacoma Water, the Pierce Conservation District, or Cooperative Extension office to help determine optimum irrigation practices.**

***Fertilizer Management:***

- **Turfgrass is most responsive to nitrogen fertilization, followed by potassium and phosphorus. Fertilization needs vary by site depending on plant, soil and climatic conditions. Evaluation of soil nutrient levels through regular testing ensures the best possible efficiency and economy of fertilization. For details on soils testing, contact the Pierce Conservation District or Cooperative Extension Service.**
- **Fertilizers should be applied in amounts appropriate for the target vegetation and at the time of year that minimizes losses to surface and ground waters. Do not fertilize during a drought or when the soil is dry. Alternatively, do not apply fertilizers within three days prior to predicted rainfall. The longer the period between fertilizer application and either rainfall or irrigation, the less fertilizer runoff occurs.**

***Use slow release fertilizers such as methylene urea, IDBU, or resin coated fertilizers when appropriate, generally in the spring. Use of slow release fertilizers is especially important in areas with sandy or gravelly soils.***

- **Time the fertilizer application to periods of maximum plant uptake. Generally fall and spring applications are recommended, although WSU turf specialists recommend four fertilizer applications per year.**
- **Properly trained persons should apply all fertilizers. At commercial and industrial facilities fertilizers should not be applied to grass swales, filter strips, or buffer areas that drain to sensitive water bodies unless approved by the local jurisdiction.**

## ***Integrated Pest Management***

### **An IPM program might consist of the following steps:**

- Step 1: Correctly identify problem pests and understand their life cycle**
- Step 2: Establish tolerance thresholds for pests.**
- Step 3: Monitor to detect and prevent pest problems.**
- Step 4: Modify the maintenance program to promote healthy plants and discourage pests.**
- Step 5: Use cultural, physical, mechanical, or biological controls first if pests exceed the tolerance thresholds.**
- Step 6: Evaluate and record the effectiveness of the control and modify maintenance practices to support lawn or landscape recovery and prevent recurrence.**

**For an elaboration of these steps refer to Appendix IV-B, Example of an Integrated Best Management Program.**

### **A3.7 PAINTING, FINISHING AND COATING OF VEHICLES, BOATS, BUILDINGS AND EQUIPMENT**

**Description of Pollutant Sources:** Surface preparation and the application of paints, finishes and/or coatings to vehicles, boats, buildings, and/or equipment outdoors can be sources of pollutants. Potential pollutants include organic compounds, oils and greases, heavy metals, and suspended solids.

**Pollutant Control Approach:** Cover and contain painting and sanding operations and apply good housekeeping and preventive maintenance practices to prevent the contamination of stormwater with painting oversprays and grit from sanding.

#### **Required BMPs**

- **Train employees in the careful application of paints, finishes, and coatings to reduce misuse and over spray. Use ground or drop cloths underneath outdoor painting, scraping, sandblasting work, and properly clean and temporarily store collected debris daily.**
- **Do not conduct spraying, blasting, or sanding activities over open water or where wind may blow paint into water.**
- **Wipe up spills with rags and other absorbent materials immediately. Do not hose down the area to a storm drain or receiving water or conveyance ditch to receiving water.**
- **On marine dock areas sweep rather than hose down debris. Collect any hose water generated and convey to appropriate treatment and disposal.**
- **Use a storm drain cover, filter fabric, or similarly effective runoff control device if dust, grit, washwater, or other pollutants may escape the work area and enter a catch basin. The containment device(s) must be in place at the beginning of the workday. Collect contaminated runoff and solids and properly dispose of such wastes before removing the containment device(s) at the end of the workday.**
- **Use a ground cloth, pail, drum, drip pan, tarpaulin, or other protective device for activities such as paint mixing and tool cleaning outside or where spills can contaminate stormwater.**
- **Properly dispose of all wastes and prevent all uncontrolled releases to the air, ground or water.**
- **Clean brushes and tools covered with non-water-based paints, finishes, or other materials in a manner that allows collection of used solvents (e.g., paint thinner, turpentine, xylol, etc.) for recycling or proper disposal.**
- **Store toxic materials under cover (tarp, etc.) during precipitation events and when not in use to prevent contact with stormwater.**

**Enclose and/or contain all work while using a spray gun or conducting sand blasting and in compliance with applicable air pollution control, OSHA, and WISHA requirements. Do not conduct outside spraying, grit blasting, or sanding activities during windy conditions which render containment ineffective.**

#### **Recommended BMPs**

- Clean paintbrushes and tools covered with water-based paints in sinks connected to sanitary sewers or in portable containers that can be dumped into a sanitary sewer drain.
- Recycle paint, paint thinner, solvents, pressure washwater, and any other recyclable materials.
- Use efficient spray equipment such as electrostatic, air-atomized, high volume/low pressure, or gravity feed spray equipment.
- Purchase recycled paints, paint thinner, solvents, and other products if feasible.

### **A3.8 COMMERCIAL PRINTING OPERATIONS**

**Description of Pollutant Sources:** Materials used in the printing process include inorganic and organic acids, resins, solvents, polyester film, developers, alcohol, vinyl lacquer, dyes, acetates, and polymers. Waste products may include waste inks and ink sludge, resins, photographic chemicals, solvents, acid and alkaline solutions, chlorides, chromium, zinc, lead, spent formaldehyde, silver, plasticizers, and used lubricating oils. As the printing operations are conducted indoors, the only likely points of potential contact with stormwater are the outside temporary storage of waste materials and offloading of chemicals at external unloading bays. Pollutants can include TSS, pH, heavy metals, oil and grease, and COD.

**Pollutant Control Approach:** Ensure appropriate disposal and NPDES permitting of process wastes. Cover and contain stored raw and waste materials.

#### **Required BMPs**

- **Discharge process wastewaters to a sanitary sewer, or to an approved process wastewater treatment system, if approved by the City of Tacoma.**
- **Do not discharge process wastes or wastewaters into storm drains or surface water.**
- **Determine whether any of these wastes qualify for regulation as dangerous wastes and dispose of them accordingly.**
- **Store raw materials or waste materials that could contaminate stormwater in covered and contained areas.**

#### **Recommended BMPs**

- Train all employees in pollution prevention, spill response, and environmentally acceptable materials handling procedures.
- Store materials in proper, appropriately labeled containers. Identify and label all chemical substances.
- All stormwater management devices should be inspected regularly and maintained as necessary.
- Try to use press washes without listed solvents, and with the lowest VOC content possible. Don't evaporate ink cleanup trays to the outside atmosphere.
- Place cleanup sludges into a container with a tight lid and dispose of as hazardous waste. Do not dispose of cleanup sludges in the garbage or in containers of soiled towels.

For additional information on pollution prevention the following Washington Department of Ecology publications are recommended: [A Guide for Screen Printers](#), Publication #94-137R and [A Guide for Lithographic Printers](#), Publication #94-139R.

### **A3.9 MANUFACTURING OPERATIONS – OUTSIDE**

**Description of Pollutant Sources:** Manufacturing pollutant sources include outside process areas, stack emissions, and areas where manufacturing activity has taken place in the past and significant pollutant materials remain and are exposed to stormwater.

**Pollution Control Approach:** Cover and contain outside manufacturing and prevent stormwater run-on and contamination, where feasible.

#### **Required BMPs**

- **Sweep paved areas regularly, as needed, to prevent contamination of stormwater.**
- **Alter the activity by eliminating or minimizing the contamination of stormwater.**
- **Enclose the activity (see Figure 4.7). If possible, enclose the manufacturing activity in a building.**
- **Cover the activity and connect floor drains to a sanitary sewer, if approved by the City of Tacoma. Berm or slope the floor as needed to prevent drainage of pollutants to outside areas (see Figure 4.8).**
- **Isolate and segregate pollutants as feasible. Convey the segregated pollutants to a sanitary sewer, process treatment or a dead-end sump depending on available methods and applicable permit requirements.**

**SECTION A4**  
**STORAGE AND STOCKPILING ACTIVITIES**

#### **A4.1 BMPs FOR STORAGE OR TRANSFER (OUTSIDE) OF SOLID RAW MATERIALS, BY-PRODUCTS OR FINISHED PRODUCTS**

**Description of Pollutant Sources:** Solid raw materials, by-products, or products such as gravel, sand, salts, topsoil, compost, logs, sawdust, wood chips, lumber and other building materials, concrete, and metal products sometimes are typically stored outside in large piles, stacks, etc. at commercial or industrial establishments. Contact of outside bulk materials with stormwater can cause leachate, and erosion of the stored materials. Contaminants include TSS, BOD, organics, and dissolved salts (sodium, calcium, and magnesium chloride, etc).

**Pollutant Control Approach:** Provide impervious containment with berms, dikes, etc. and/or cover to prevent run-on and discharge of leachate pollutant(s) and TSS.

##### **Required BMPs**

- **Do not hose down the contained stockpile area to a storm drain or a conveyance to a storm drain or to receiving water.**
- **Choose one or more of the source control BMP options listed below for stockpiles greater than 5 cubic yards of erodible or water soluble materials such as soil, road deicing salts, compost, unwashed sand and gravel, sawdust, etc. Also included are outside storage areas for solid materials such as logs, bark, lumber, metal products, etc.**
- **Store in a building or paved and bermed covered area as shown in Figure 4.9, or;**
- **Place temporary plastic sheeting (polyethylene, polypropylene, hypalon, or equivalent) over the material as illustrated (see Figure 4.10), or;**
- **Pave the area and install a stormwater drainage system. Place curbs or berms along the perimeter of the area to prevent the run-on of uncontaminated stormwater and to collect and convey runoff to treatment. Slope the paved area in a manner that minimizes the contact between stormwater (e.g., pooling) and leachable materials in compost, logs, bark, wood chips, etc.**
- **For large stockpiles that cannot be covered, implement containment practices at the perimeter of the site and at any catch basins as needed to prevent erosion and discharge of the stockpiled material offsite or to a storm drain. Ensure that contaminated stormwater is not discharged directly to catch basins without being conveyed through a treatment BMP.**
- **Convey contaminated stormwater from the stockpile area to a wet pond, wet vault, settling basin, media filter, or other appropriate treatment system depending on the contamination.**



**Recommended BMPs:**

- Maintain drainage areas in and around storage of solid materials with a minimum slope of 1.5 percent to prevent pooling and minimize leachate formation. Areas should be sloped to drain stormwater to the perimeter where it can be collected, or to internal drainage “alleyways” where material is not stockpiled.
- Sweep paved storage areas regularly for collection and disposal of loose solid materials.
- If and when feasible, collect and recycle water-soluble materials (leachates) to the stockpile
- Stock cleanup materials, such as brooms, dustpans, and vacuum sweepers near the storage area.

## **A4.2 STORAGE AND TREATMENT OF CONTAMINATED SOILS**

**Description of Pollutant Sources:** This activity applies to businesses and agencies that store and treat soils contaminated with toxic organic compounds, petroleum products, or heavy metals. Such contamination typically comes to light when an environmental audit is done, or old underground tanks are removed. The soils are usually excavated and taken off-site for treatment via aeration and perhaps chemical stabilization. Stormwater runoff that comes in contact with contaminated soil can carry those contaminants along with loose dirt into receiving waters.

Pollutants of concern include toxic organic compounds, oils and greases and heavy metals.

**Pollutant Control Approach:** The Tacoma-Pierce County Health Department Waste Management Section at (253) 798-6047 regulates and permits businesses treating contaminated soil. In addition, a permit from the Puget Sound Clean Air Agency is required if the treatment method for removing soil contaminants involves forcing air through, or sucking air from, the soil. Contact these agencies for additional information regarding the appropriate pollutant control approach.

### **Required BMPs**

**The BMPs included here are intended as a supplement to other regulations. The following BMPs or equivalent measures are required of all businesses engaged in storage and treatment of contaminated soils:**

- **The storage area for contaminated soils must be enclosed indoors, covered, or contained by a curb, dike, or berm constructed around the material storage area. If the contaminated soils are covered, stormwater run-on protection must also be provided. BMP S.7 in Chapter 5 provides further details on containment and run-on prevention.**
- **Employees must be educated on methods to prevent contamination from leaving the site.**
- **Cleanup materials must be stocked near the storage area.**
- **Gutters, storm drains, catch basins, and other drainage system features on the site must be cleaned following the completion of site work, or at least once per year, whichever comes first. Sediments from such cleaning must be disposed of properly. See BMP S.9 and S.2 for details on catch basin cleaning and disposal options.**

### **Recommended BMPs**

The following BMPs are not required but can provide additional pollution protection:

- **If feasible, the storage area should be swept weekly for collection of stray soil, which can be added back to the piles, or properly disposed. See BMP S.2 in Chapter 5 for information on disposal options.**

- Implement one of the following treatment BMPs in conjunction with a runoff containment plan:
  - Vegetated biofilter.
  - Catch basin insert for the targeted pollutants or wet vault.
  - Or equivalent BMP, see Volume V.

The use of any treatment BMP must not result in the violation of groundwater, surface water, or drinking water quality standards.

### **A4.3 TEMPORARY STORAGE OR PROCESSING OF FRUITS OR VEGETABLES**

**Description of Pollutant Sources:** This activity applies to businesses that temporarily store fruits and vegetables outdoors prior to processing or sale, or that crush, cut, or shred fruits or vegetables for wines, frozen juices, and other food and beverage products. Nutrients and soil washing off of fruit can have a detrimental effect on receiving waters.

Pollutants of concern include nutrients, suspended solids, biochemical oxygen demand (BOD) and color.

**Pollutant Control Approach:** Store and process fruits and vegetables indoors or under cover whenever possible. Educate employees about proper procedures. Eliminate illicit connections to the storm drainage system. Cover and contain operations and apply good housekeeping and preventive maintenance practices to prevent the contamination of stormwater.

#### **Required BMPs**

**The following BMPs or equivalent measures are required of all businesses engaged in storage of fruits or vegetables:**

- **Employees must be educated on benefits of keeping a clean storage area.**
- **Eliminate illicit connections to the storm drainage system. See BMP S.1 in Chapter 5 for details on detecting and eliminating these connections.**
- **No untreated water used to clean produce can enter the storm drainage system. Minimize the use of water when cleaning produce to avoid excess runoff.**
- **Cleanup materials, such as brooms and dustpans, must be kept near the storage area.**
- **Gutters, storm drains and catch basins on the property must be cleaned as needed. See BMP S.9 in Chapter 5 for details on catch basin cleaning requirements.**

**The following BMPs or equivalent measures are required of all businesses that process fruits or vegetables:**

- **Eliminate illicit connections to the storm drainage system. See BMP S.1 in Chapter 5 for details on detecting and eliminating these connections.**
- **Employees must be educated on benefits of keeping a clean processing area.**
- **Cleanup materials, such as brooms, dustpans and shovels, must be kept near the storage area.**
- **The processing area must be swept or shoveled daily to collect dirt, fruit and vegetable fragments for proper disposal.**

- **The processing area must be enclosed in a building or shed, or covered with provisions for stormwater run-on prevention. See BMP S.4, S.5, and S.7 in Chapter 5 for more on covering and run-on prevention.**

**OR**

**The processing area must be paved and sloped to a sanitary sewer drain, holding tank, or process treatment system collection drain, and stormwater run-on prevention must be provided for the processing area. Call the Tacoma Sanitary Source Control Unit at 591-5588 for information on discharging to the sanitary sewer. See BMP S.6 and S.3 in Chapter 5 for details on paving and drainage.**

### **Recommended BMPs**

The following BMPs are not required but can provide additional pollution protection:

- Cover storage areas for fruits and vegetables. See BMP S.4 and S.5 in Chapter 5 for more details on coverings.
- A containment curb, dike, or berm can be used to prevent offsite runoff from storage or processing areas and also to prevent stormwater run-on. See BMP S.7 in Chapter 5 for more information. Note that run-on prevention is required for processing areas, but not for storage areas.
- The storage area should be swept or shoveled daily to collect dirt and fruit and vegetable fragments for proper disposal. Keep hosing to a minimum.
- Use one or a combination of the following treatment BMPs:
  - Wet pond or wet vault to treat storage area runoff.
  - Vegetated biofilter to treat storage area runoff.
  - Catch basin, with appropriate insert for the targeted pollutants, to treat storage area runoff. See S.9 in Chapter 5 for information on catch basin cleaning.
  - Or equivalent BMP, see Volume V.

#### **A4.4 STORAGE OF SOLID WASTES AND FOOD WASTES**

**Description of Pollutant Sources:** This activity applies to businesses and public agencies that store solid wastes and food wastes outdoors. This includes ordinary garbage. If improperly stored in our climate, these wastes can contribute a variety of different pollutants to stormwater. Requirements for handling and storing solid waste may require a permit from the Tacoma-Pierce County Health Department. For more information, call the Waste Management Section at 253-798-6047.

NOTE: Dangerous solid wastes must be stored and handled under special guidelines. Businesses and agencies that store dangerous wastes must follow specific regulations outlined by the Department of Ecology, and in some cases, the Tacoma-Pierce County Health Department (TPCHD). Ecology regulations are outlined in Chapter 6. Please contact the Department of Ecology at 360-407-6300 and the TPCHD at 253-798-6047 for the specific requirements and permitting information.

Pollutants of concern include toxic organic compounds, oils and greases, heavy metals, nutrients, suspended solids, chemical oxygen demand (COD) and biochemical oxygen demand (BOD).

**Pollutant Control Approach:** Store wastes in suitable containers with leak proof lids. Sweep or shovel loose solids. Educate employees about the need to check for and replace leaking containers.

#### **Required BMPs**

**The following BMPs are required of all businesses and public agencies engaged in storage of non-dangerous solid wastes or food wastes:**

- **All solid and food wastes must be stored in suitable containers. Piling of wastes without any cover is not acceptable.**
- **Storage containers must be checked for leaks and replaced if they are leaking, corroded, or otherwise deteriorating.**
- **Storage containers must have leak-proof lids, or else be covered by some other means. Lids must be kept closed at all times. This is especially important for dumpsters, as birds can pick out garbage and drop it, promoting rodent, health and stormwater problems.**

**OR**

**If lids cannot be provided for the waste containers, or they cannot otherwise be covered, there is another option: a designated waste storage area must be provided with a containment berm, dike or curb, and the designated area must drain to a sanitary sewer or holding tank for further treatment. See BMP S.7 and S.3 in Chapter 5 for more information.**

- **Employees must be trained to frequently check storage containers for leaks and to ensure that the lids are on tightly.**

- **The waste storage area must be swept or otherwise cleaned frequently to collect all loose solids for proper disposal in a storage container. Do not hose the area to collect or clean solids.**
- **If you clean your containers, all rinse water from cleaning must be disposed of in a sanitary sewer or septic system.**
- **Clean out catch basins on your property that receive drainage from your waste storage area. See BMP S.9 in Chapter 5 for details on catch basin cleaning.**

### **Recommended BMPs**

The following BMPs are not required, but can provide additional pollution protection:

- If the amount of waste accumulated appears to frequently exceed the capacity of the storage container, then another storage container should be obtained and utilized.
- Store containers such that wind will not be able to knock them over.
- Designate a storage area, pave the area, and slope the drainage to a holding tank or sanitary sewer drain. If a holding tank is used, the contents must be pumped out before the tank is full, and properly disposed. See BMP S.2 in Chapter 5 for more information on disposal options.
- Compost appropriate wastes. Contact Tacoma Solid Waste Utility Recycling and Composting at 253-565-5955 for more information on composting.
- Recycle your solid wastes. The Industrial Materials Exchange (IMEX) program facilitates the transfer of excess materials and wastes to those who can use them. IMEX can be reached at 206-296-4899, or use the IMEX computer bulletin board modem access number at 1-800-858-6625.

#### **A4.5 RECYCLERS AND SCRAP YARDS**

**Description of Pollutant Sources:** Includes businesses that reclaim various materials for resale or for scrap, such as vehicles and vehicle/ equipment parts, construction materials, metals, beverage containers, and papers.

Potential sources of pollutants include paper, plastic, metal scrap debris, engines, transmissions, radiators, batteries, and other materials that contain fluids or are contaminated with fluids. Other pollutant sources include leachate from metal components, contaminated soil, and the erosion of soil. Activities that can generate pollutants include the transfer, dismantling, and crushing of vehicles and scrap metal; the transfer and removal of fluids; maintenance and cleaning of vehicles, parts, and equipment; and storage of fluids, parts for resale, solid wastes, scrap parts, and materials, equipment and vehicles that contain fluids; generally in uncovered areas.

Potential pollutants typically found at vehicle recycle and scrap yards include oil and grease, ethylene and propylene glycol, total suspended solids, BOD, heavy metals, and acidic pH.

#### **Required BMPs**

**For facilities subject to Ecology's Industrial Stormwater General Permit refer to BMP Guidance Document #94-146, "Best Management Practices to Prevent Stormwater Pollution at Vehicle Recycler Facilities," Washington Department of Ecology, September 1994 for selection of BMPs. The BMPs in that guidance document can also be applied to scrap material recycling facilities depending on the pollutant sources existing at those facilities and to non-permitted facilities.**



#### **A4.6 TREATMENT, STORAGE, OR DISPOSAL OF DANGEROUS WASTES**

This activity applies to businesses and public agencies that are permitted by the Washington State Department of Ecology to treat, store, or dispose of dangerous wastes. DOE regulates these facilities with specific requirements, which include the need for a National Pollutant Discharge Elimination System (NPDES) permit. Detailed BMPs are not included in this manual since site requirements for these facilities are well beyond the level of typical BMP applications. See Chapter 6 for reference information.

The Tacoma-Pierce County Health Department also administers some aspects of dangerous waste treatment, storage and disposal. Call 253-798-6047 for more information.

## **A4.7 STORAGE OF LIQUID, FOOD WASTE OR DANGEROUS WASTE CONTAINERS**

**Description of Pollutant Sources:** Steel and plastic drums with volumetric capacities of 55 gallons or less are typically used at industrial facilities for container storage of liquids and powders. The BMPs specified below apply to container(s) located outside a building used for temporary storage of accumulated food wastes, vegetable or animal grease, used oil, liquid feedstock or cleaning chemical, or Dangerous Wastes (liquid or solid) unless the business is permitted by Ecology to store the wastes. Leaks and spills of pollutant materials during handling and storage are the primary sources of pollutants. Oil and grease, acid/alkali pH, BOD, and COD are potential pollutant constituents.

**Pollutant Control Approach:** Store containers in impervious containment under a roof or other appropriate cover, or in a building. For roll-containers (for example, dumpsters) that are picked up directly by the collection truck, a filet can be placed on both sides of the curb to facilitate moving the dumpster. If a storage area is to be used on-site for less than 30 days, a portable temporary secondary system like that shown in Figure 4.11 can be used in lieu of a permanent system as described above.

### **Required BMPs**

- **Place tight-fitting lids on all containers.**
- **Place drip pans beneath all mounted container taps and at all potential drip and spill locations during filling and unloading of containers.**
- **Inspect container storage areas regularly for corrosion, structural failure, spills, leaks, overfills, and failure of piping systems. Check containers daily for leaks/spills. Replace containers, and replace and tighten bungs in drums as needed.**
- **Businesses accumulating Dangerous Wastes that do not contain free liquids need only to store these wastes in a sloped designated area with the containers elevated or otherwise protected from stormwater run-on.**
- **Drums stored in an area where unauthorized persons may gain access must be secured in a manner that prevents accidental spillage, pilferage, or any unauthorized use (see Figure 4.12).**
- **If the material is a Dangerous Waste, the business owner must comply with any additional Ecology requirements as specified in Chapter 6, Section 6.2, R.2.**
- **Storage of reactive, ignitable, or flammable liquids must comply with the Uniform Fire Code.**
- **Cover dumpsters, or keep them under cover such as a lean-to, to prevent the entry of stormwater. Replace or repair leaking garbage dumpsters.**
- **Drain dumpsters and/or dumpster pads to sanitary sewer. Keep dumpster lids closed. Install waterproof liners.**

- **Keep containers with Dangerous Waste, food waste, or other potential pollutant liquids inside a building unless this is impracticable due to site constraints or Uniform Fire Code requirements.**
- **Store containers in a designated area, which is covered, bermed or diked, paved and impervious in order to contain leaks and spills (see Figure 2.10). The secondary containment shall be sloped to drain into a dead-end sump for the collection of leaks and small spills.**
- **For liquid wastes, surround the containers with a dike as illustrated in Figure 2.10. The dike must be of sufficient height to provide a volume of either 10 percent of the total enclosed container volume or 110 percent of the volume contained in the largest container, whichever is greater, or, if a single container, 110 percent of the volume of that container.**
- **Where material is temporarily stored in drums, a containment system can be used as illustrated, in lieu of the above system (see Figure 4.13).**
- **Place containers mounted for direct removal of a liquid chemical for use by employees inside a containment area as described above. Use a drip pan during liquid transfer (see Figure 4.14).**
- **For contaminated stormwater in the containment area, connect the sump outlet to a sanitary sewer, if approved by the City of Tacoma, or to appropriate treatment such as an API or CP oil/water separator, catch basin filter or other appropriate system (see Volume V). Equip the sump outlet with a normally closed valve to prevent the release of spilled or leaked liquids, especially flammables (compliance with Fire Codes), and dangerous liquids. This valve may be opened only for the conveyance of contaminated stormwater to treatment.**
- **Another option for discharge of contaminated stormwater is to pump it from a dead-end sump or catchment to a tank truck or other appropriate vehicle for off-site treatment and/or disposal.**

## **A4.8 STORAGE OF LIQUIDS IN PERMANENT ABOVE-GROUND TANKS**

**Description of Pollutant Sources:** Above-ground tanks containing liquids (excluding uncontaminated water) may be equipped with a valved drain, vent, pump, and bottom hose connection. They may be heated with steam heat exchangers equipped with steam traps. Leaks and spills can occur at connections and during liquid transfer. Oil and grease, organics, acids, alkalis, and heavy metals in tank water and condensate drainage can also cause stormwater contamination at storage tanks.

**Pollutant Control Approach:** Install secondary containment or a double-walled tank. Slope the containment area to a drain with a sump. Stormwater collected in the containment area may need to be discharged to treatment such as an API or CP oil/water separator, or equivalent BMP. Add safeguards against accidental releases including protective guards around tanks to protect against vehicle or forklift damage, and tagging valves to reduce human error. *Tank water and condensate discharges are process wastewater that may need an NPDES Permit.*

### **Required BMPs**

- **Inspect the tank containment areas regularly to identify problem components such as fittings, pipe connections, and valves, for leaks/spills, cracks, corrosion, etc.**
- **Place adequately sized drip pans beneath all mounted taps and drip/spill locations during filling/unloading of tanks. Valved drain tubing may be needed in mounted drip pans.**
- **Sweep and clean the tank storage area regularly, if paved.**
- **Replace or repair tanks that are leaking, corroded, or otherwise deteriorating.**
- **All installations shall comply with the Uniform Fire Code and the National Electric Code.**
- **Locate permanent tanks in impervious (Portland cement concrete or equivalent) secondary containment surrounded by dikes as illustrated in Figure 4.15, or UL Approved double-walled. The dike must be of sufficient height to provide a containment volume of either 10 percent of the total enclosed tank volume or 110 percent of the volume contained in the largest tank, whichever is greater, or, if a single tank, 110 percent of the volume of that tank.**
- **Slope the secondary containment to drain to a dead-end sump (optional), or equivalent, for the collection of small spills.**
- **Include a tank overfill protection system to minimize the risk of spillage during loading.**
- **If the tank containment area is uncovered, equip the outlet from the spill-containment sump with a shutoff valve, which is normally closed and may be opened, manually or automatically, only to convey contaminated stormwater to approved treatment or disposal, or to convey uncontaminated stormwater to a storm drain. Evidence of contamination can include the presence of visible sheen, color, or turbidity in the**

**runoff, or existing or historical operational problems at the facility. Simple pH measurements with litmus or pH paper can be used for areas subject to acid or alkaline contamination.**

- **At petroleum tank farms, convey stormwater contaminated with floating oil or debris in the contained area through an API or CP-type oil/water separator (Volume V, Treatment BMPs), or other approved treatment prior to discharge to storm drain or surface water.**

#### **A4.9 PARKING AND STORAGE FOR VEHICLES AND EQUIPMENT**

**Description of Pollutant Sources:** Public and commercial parking lots such as retail store, fleet vehicle (including rent-a-car lots and car dealerships), equipment sale and rental parking lots, and parking lot driveways, can be sources of toxic hydrocarbons and other organic compounds, oils and greases, metals, and suspended solids caused by the parked vehicles.

##### **Required BMPs**

- **If washing of a parking lot is conducted, discharge the washwater to a sanitary sewer, or other approved wastewater treatment system, if allowed by the City of Tacoma, or collect it for off-site disposal.**
- **Do not hose down the area to a storm drain or to a receiving water. Sweep parking lots, storage areas, and driveways, regularly to collect dirt, waste, and debris.**
- **An oil removal system such as an API or CP oil and water separator, catch basin filter, or equivalent BMP (see Volume V), approved by the City of Tacoma, is applicable for parking lots meeting the threshold vehicle traffic intensity level of a high-use site. For more information on high use sites, refer to Volume I, Section 4.2, Step V, Step 2.**

#### **A4.10 LOADING AND UNLOADING AREAS FOR SOLID MATERIAL**

**(Please refer to A2.1, Loading and Unloading Areas for Liquid and Solid Material.)**

**SECTION A5**  
**CONSTRUCTION AND DEMOLITION ACTIVITIES**



## **A5.1 CLEARING, GRADING AND PREPARATION OF CONSTRUCTION SITES**

This activity applies to businesses and municipal agencies that develop lands for construction. It also applies to residences that undertake large yard clearing and grading projects. Stormwater runoff from bare ground can be loaded with dirt and other pollutants. This material can clog ditches and stream channels, thus reducing carrying capacity and increasing flooding, as well as smothering spawning beds for fish. Simply controlling runoff and not allowing it to leave the site will prevent these harmful effects. Clearing, grading and preparation activities are covered in detail in Volume II of this Manual, Construction Stormwater Pollution Prevention. Grading activities are also regulated in the City of Tacoma by the Grading and Excavation Code, Section 2.02.330 of the official code of the City of Tacoma.

An NPDES permit is needed from the Washington state Department of Ecology (Ecology) where five (5) or more acres of land is disturbed. Beginning in 2003, coverage under Ecology's General Permit will be required for construction sites that result in the disturbance of one acre or more of land. Compliance with the Construction Stormwater Pollution Prevention requirements in Ecology's manual is required, as applicable.

## **A5.2 DEMOLITION OF BUILDINGS**

**Description of Pollutant Sources:** This activity applies to removal of existing buildings by controlled explosions, wrecking balls, or manual methods, and subsequent clearing of the rubble. The loose debris can contaminate stormwater.

Pollutants of concern include toxic organic compounds, heavy metals and suspended solids.

**Pollutant Control Approach:** Regularly clean up debris that can contaminate stormwater. Protect the storm drainage system from dirty runoff and loose particles. Sweep paved surfaces daily.

### **Required BMPs**

**The following BMPs or equivalent measures are required of all businesses and public agencies engaged in building demolition:**

- **1. Storm drain covers or a similarly effective containment device must be placed on all nearby drains to prevent dirty runoff and loose particles from entering the storm drainage system. Covers shall be placed at the beginning of the work day and the accumulated materials collected and disposed before removing the covers at the end of the work day. If storm drains are not present, dikes, berms or other methods must be used to protect overland discharge paths from runoff. See BMP S.2 and S.7 in Chapter 5 for more information on runoff control and disposal options.**
- **2. Street gutters, sidewalks, driveways, and other paved surfaces in the immediate area of the demolition must be swept at the end of each work day to collect and properly dispose of loose debris and garbage.**

### **Recommended BMPs**

The following BMPs are not required but can provide additional pollution protection:

- Water should be sprayed throughout the site to help control wind blowing of fine materials such as soil, concrete dust, and paint chips. The amount of water must be controlled so that runoff from the site does not occur, yet dust control is achieved. Oils must never be used for dust control.
- If possible, a wall should be constructed to prevent stray building materials and dust from escaping the area during demolition.
- Install catch basin filter inserts to treat site runoff. Additional information about catch basin filter inserts can be found in Volume V of this Manual, Runoff Treatment BMPs.
- Schedule demolition to take place at a dry time of the year.

### **A5.3 BUILDING REPAIR, REMODELING AND CONSTRUCTION**

**Description of Pollutant Sources:** This activity refers to activities associated with construction of buildings and other structures, remodeling of existing buildings and houses, and general exterior building repair work. Painting of buildings is covered under **A3.10 Painting, Finishing and Coating of Vehicles, Boats, Buildings and Equipment**. Concrete pouring is covered under **A3.2 Concrete Pouring and Asphalt Application at Temporary Sites**.

Pollutants of concern include toxic hydrocarbons, toxic organics, suspended solids, heavy metals, pH, oils and greases.

**Pollutant Control Approach:** Employees must be educated about the need to control site activities. Control leaks, spills and loose material. Utilize good housekeeping practices.

#### **Required BMPs**

The following BMPs or equivalent measures are required of all businesses engaged in building repair, remodeling and construction:

- **Employees must be educated about the need to control site activities to prevent stormwater pollution, and also trained in spill cleanup procedures.**
- **Spill cleanup materials, appropriate to the chemicals being used on site, must be available at the work site at all times.**
- **The work site must be cleaned up at the end of each work day, with materials such as solvents put away indoors or covered and secured so that vandals will not have access to them.**
- **The area must be swept daily to collect loose litter, paint chips, grit, and dirt.**
- **Absolutely no substance can be dumped on pavement, on the ground, in or toward storm drains, regardless of its content, unless it is water only.**
- **Ground or drop cloths must be used underneath scraping and sandblasting work. Groundcloths, buckets, or tubs must also be used anywhere that work materials are laid down.**
- **Tools covered with non-water-based finishes, or other materials must be cleaned in a manner that enables collection of used solvents for recycling or proper disposal. See BMP S.2 in Chapter 5 for disposal options.**
- **Storm drain covers or similarly effective devices must be used if dust, grit, washwater, or other pollutants may escape the work area. This is particularly necessary on rainy days. The cover or containment device shall be placed over the storm drain at the beginning of the work day, and accumulated dirty runoff and solids must be collected and disposed of before removing the cover at the end of the day.**

## **Recommended BMPs**

The following BMPs are not required but can provide additional pollution protection:

- Recycle materials whenever possible.
- Light spraying of water on the work site can control some of the dust and grit that can blow away. Oils must never be used for dust control. Never spray to the point of runoff from the site.
- Activities such as tool cleaning should occur over a ground cloth or within a containment device such as a tub.
- Catch basin filter inserts should be considered if work will be ongoing for an extended period of time or if significant amounts of hydrocarbons, oils and greases, heavy metals, or suspended solids are expected in site runoff. Additional information about catch basin filter inserts can be found in Volume V of this Manual, Runoff Treatment BMPs.

**SECTION A6**  
**DUST CONTROL AND SOIL AND SEDIMENT CONTROL**

## **A6.1 BMPs FOR DUST CONTROL AT DISTURBED LAND AREAS AND UNPAVED ROADWAYS AND PARKING LOTS**

**Description of Pollutant Sources:** Dust can cause air and water pollution problems particularly at demolition sites, disturbed land areas, and unpaved roadways and parking lots.

**Pollutant Control Approach:** Minimize dust generation and apply environmentally friendly and government approved dust suppressant chemicals, if necessary.

### **Required BMPs**

- **Sprinkle or wet down soil or dust with water as long as it does not result in a wastewater discharge.**
- **Use only local and/or state government approved dust suppressant chemicals such as those listed in Ecology Publication #96-433, "Techniques for Dust Prevention and Suppression."**
- **Avoid excessive and repeated applications of dust suppressant chemicals. Time the application of dust suppressants to avoid or minimize their wash-off by rainfall or human activity such as irrigation.**
- **Apply stormwater containment to prevent the conveyance of stormwater TSS into storm drains or receiving waters.**
- **The use of motor oil or other oils for dust control is prohibited. Care should be taken when using lignin derivatives and other high BOD chemicals in excavations or areas easily accessible to surface water or ground water.**
- **Consult with the Ecology Regional Office in your area on discharge permit requirements if the dust suppression process results in a wastewater discharge to the ground, ground water, storm drain, or surface water.**

### **Recommended BMPs for Roadways and Other Trafficked Areas:**

- Consider limiting use of off-road recreational vehicles on dust generating land.
- Consider paving unpaved permanent roads and other trafficked areas at municipal, commercial, and industrial areas.
- Consider paving or stabilizing shoulders of paved roads with gravel, vegetation, or local government approved chemicals.
- Encourage use of alternate paved routes, if available.
- Vacuum or wet sweep fine dirt and skid control materials from paved roads soon after winter weather ends or when needed.
- Consider using traction sand that is pre-washed to reduce dust emissions.

**Recommended BMPs for Dust Generating Areas:**

- Prepare a dust control plan. Helpful references include: Control of Open Fugitive Dust Sources (EPA-450/3-88-088), and Fugitive Dust Background Document and Technical Information Document for Best Available Control Measures (EPA-450/2-92-004)
- Limit exposure of soil (dust source) as much as feasible.
- Stabilize dust-generating soil by growing and maintaining vegetation, mulching, topsoiling, and/or applying stone, sand, or gravel.
- Apply windbreaks in the soil such as trees, board fences, tarp curtains, bales of hay, etc.
- Cover dust-generating piles with wind-impervious fabric, or equivalent material.

## **A6.2 DUST CONTROL AT MANUFACTURING SITES**

**Description of Pollutant Sources:** Industrial material handling activities can generate considerable amounts of dust that is typically removed using exhaust systems. This can generate air emissions that can contaminate stormwater. Dusts can be generated at cement and concrete products mixing, and wherever powdered materials are handled. Particulate materials that are of concern to air pollution control agencies include grain dust, sawdust, coal, gravel, crushed rock, cement, and boiler fly ash. The objective of this BMP is to reduce the stormwater pollutants caused by dust generation and control.

**Pollutant Control Approach:** Prevent dust generation and emissions where feasible, regularly clean-up dust that can contaminate stormwater, and convey dust contaminated stormwater to proper treatment.

### **Required BMPs**

- **Clean, as needed, powder material handling equipment and vehicles that can be sources of stormwater pollutants, to remove accumulated dust and residue.**
- **Regularly sweep dust accumulation areas that can contaminate stormwater. Sweeping should be conducted using vacuum filter equipment to minimize dust generation and to ensure optimal dust removal.**

### **Recommended BMPs**

- In manufacturing operations, train employees to carefully handle powders to prevent generation of dust.
- Use dust filtration/collection systems such as bag house filters, cyclone separators, etc. to control vented dust emissions that could contaminate stormwater. Control of zinc dusts in rubber production is one example.
- Use water spray to flush dust accumulations to sanitary sewers where allowed by the City of Tacoma or to other appropriate treatment system.
- Use approved dust suppressants such as those listed in Ecology Publication "Techniques for Dust Prevention and Suppression," #96-433. (Ecology, 1996). Application of some products may not be appropriate in close proximity to receiving waters or conveyances close to receiving waters. For more information check with the Ecology Regional Office or the local jurisdiction.
- For removal of TSS in stormwater use sedimentation basins, wet ponds, wet vaults, catch basin filters, vegetated filter strips, or equivalent sediment removal BMPs. Refer to Volume V Runoff Treatment BMPs for more information about these BMPs.



### **A6.3 SOIL EROSION AND SEDIMENT CONTROL AT INDUSTRIAL SITES**

**Description of Pollutant Sources:** Industrial activities on soil areas; exposed and disturbed soils; steep grading; etc. can be sources of sediments that can contaminate stormwater runoff.

**Pollutant Control Approach:** Limit the exposure of erodible soil, stabilize or cover erodible soil where necessary to prevent erosion, and/or provide treatment for stormwater contaminated with TSS caused by eroded soil.

#### **Required BMPs**

- **Vegetative cover such as grass, trees, shrubs, on erodible soil areas; or,**
- **Covering with mats such as clear plastic, jute, synthetic fiber; and/or,**
- **Preservation of natural vegetation including grass, trees, shrubs, and vines, vegetated swale, dike, silt fence, check dam, gravel filter berm, sedimentation basin, and proper grading. (For design information refer to Volume II, “Standards and Specifications for BMPs”).**

**SECTION A7  
OTHER ACTIVITIES**

## **A7.1 COMMERCIAL ANIMAL HANDLING AREAS**

**Description of Pollutant Sources:** Animals at racetracks, kennels, fenced pens, veterinarians, and businesses that provide boarding services for horses, dogs, cats, etc., can generate pollutants from the following activities: manure deposits, animal washing, grazing and any other animal handling activity that could contaminate stormwater. Pollutants can include coliform bacteria, nutrients, and total suspended solids.

**Pollutant Control Approach:** To prevent, to the maximum extent practicable, the discharge of contaminated stormwater from animal handling and keeping areas.

### **Required BMPs**

- **Regularly sweep and clean animal keeping areas to collect and properly dispose of droppings, uneaten food, and other potential stormwater contaminants.**
- **Do not hose down to storm drains or to receiving water those areas that contain potential stormwater contaminants.**
- **Do not allow any washwaters to be discharged to storm drains or to receiving water without proper treatment.**
- **If animals are kept in unpaved and uncovered areas, the ground must either have vegetative cover or some other type of ground cover such as mulch.**
- **If animals are not leashed or in cages, the area where animals are kept must be surrounded by a fence or other means that prevents animals from moving away from the controlled area where BMPs are used.**

## **A7.2 LOG SORTING AND HANDLING**

**Description of Pollutant Sources:** Log yards are paved or unpaved areas where logs are transferred, sorted, debarked, cut, and stored to prepare them for shipment or for the production of dimensional lumber, plywood, chips, poles, or other products. Log yards are generally maintained at sawmills, shipping ports, and pulp mills. Typical pollutants include oil and grease, BOD, settleable solids, total suspended solids (including soil), high and low pH, heavy metals, pesticides, wood-based debris, and leachate.

The following are pollutant sources:

1. Log storage, rollout, sorting, scaling, and cutting areas
2. Log and liquid loading areas
3. Log sprinkling
4. Debarking, bark bin and conveyor areas
5. Bark, ash, sawdust and wood debris piles, and other solid wastes
6. Metal salvage areas
7. Truck, rail, ship, stacker, and loader access areas
8. Log trucks, stackers, loaders, forklifts, and other heavy equipment
9. Maintenance shops and parking areas
10. Cleaning areas for vehicles, parts, and equipment
11. Storage and handling areas for hydraulic oils, lubricants, fuels, paints, liquid wastes, and other liquid materials
12. Pesticide usage for log preservation and surface protection
13. Application of herbicides for weed control
14. Contaminated soil resulting from leaks or spills of fluids

### **Ecology's Baseline General Permit Requirements:**

Industries with log yards are required to obtain coverage under the baseline general permit for discharges of stormwater associated with industrial activities to surface water. The permit requires preparation and on-site retention of Stormwater Pollution Prevention Plans (SWPPP). The SWPPP must identify operational, source control, erosion and sediment control and, if necessary, treatment BMPs. Required and recommended operational, source control, and treatment BMPs are presented in detail in Ecology's Guidance Document: Best Management Practices to Prevent Stormwater Pollution at Log Yards, Publication # 95-53, May 1995. It is recommended that all log yard facilities obtain a copy of this document. Ecology is revising this manual. The revised BMP Manual for Log Yards should be available January 31, 2003.

### **A7.3 BOAT BUILDING, MOORING, MAINTENANCE AND REPAIR**

**Description of Pollutant Sources:** Sources of pollutants at boat and shipbuilding, repair, and maintenance at boatyards, shipyards, ports, and marinas include pressure washing, surface preparation, paint removal, sanding, painting, engine maintenance and repairs, and material handling and storage, if conducted outdoors. Potential pollutants include spent abrasive grits, solvents, oils, ethylene glycol, washwater, paint over-spray, cleaners/ detergents, anti-corrosive compounds, paint chips, scrap metal, welding rods, resins, glass fibers, dust, and miscellaneous trash. Pollutant constituents include TSS, oil and grease, organics, copper, lead, tin, and zinc.

**Pollutant Control Approach:** Apply good housekeeping, preventive maintenance and cover and contain BMPs in and around work areas.

#### **Required BMPs**

The following BMPs or equivalent measures are required of all businesses, public agencies and private boat owners engaged in boat building, mooring, maintenance and repair that are not covered by the NPDES permit for boatyards:

- **Maintenance and repair activities that can be moved on-shore must be moved accordingly. This action reduces some of the potential for direct pollution impact on waterbodies.**
- **Blasting and spray painting activities must be sheltered by hanging tarps to block the wind and prevent dust and overspray from escaping. Move the activity indoors if possible. See Chapter 6 for details on Puget Sound Clean Air Agency limitations.**
- **Ground cloths must be used for collection of drips and spills in painting and finishing operations, and paint chips and used blasting sand from sand blasting.**
- **Bilge water must be collected for proper disposal rather than discharged on land or water. See BMP S.2 in Chapter 5 for detail on disposal options. Several companies are available for bilge pumpout services. The problem can be avoided if oil-absorbent pads are used to capture the oil in the bilge water before or during pumping. If pads are used, they must be recycled or properly disposed.**
- **Ballast water that has an oily sheen on the surface must be collected for proper disposal rather than discharged on land or water. See BMP S.2 in Chapter 5 for details on disposal options.**
- **Maintenance yard areas must be swept and cleaned, without hosing down the area, at least once per week or as needed. This prevents sandblasting materials, scrapings, paint chips, oils, and other loose debris from being carried away with stormwater. The collected materials must be disposed of properly. See BMP S.2 in Chapter 5 for disposal options.**
- **Docks and boat ramps must be swept at least once per week or as needed, and the collected materials must be disposed of properly. Dry docks must be swept before flooding.**

- **Paint and solvent mixing, fuel mixing and similar handling of liquids shall be performed on shore, or such that no spillage can occur directly into surface waterbodies.**
- **Routine cleanup materials such as oil-absorbent pads, brooms, dustpans, mops, buckets, and sponges must be stocked near docks.**
- **When washing your boat in the water, use no soaps or detergents. Brush the hull with water only.**
- **Comply with BMP A2.3 and A4.2 if engine repair and maintenance are conducted.**

### **Recommended BMPs**

The following BMPs are not required but can provide additional pollution protection:

- Boat construction and structural repair activities should be covered.
- Materials such as paints, tools, and ground cloths should be stored indoors or in a covered area when not in use.
- Select the least toxic anti-fouling paint available.
- Boat interiors should be routinely cleaned, with proper disposal of collected materials, so that accumulations of water drained from them are not contaminated.
- Use sanders that have dust containment bags and avoid sanding in windy conditions.
- All used oil should be recycled if feasible. Most marinas now offer used oil recycling services. To dispose of filters, let drain 24 hours, then double wrap in plastic and dispose in the regular garbage, or take them to the Tacoma Landfill Household Hazardous Waste facility for recycling. Pending state legislation may make disposal in the garbage illegal, so call the Hazardous Waste Line at 1-800-287-6429 for current information.
- Citizens for a Healthy Bay, a local environmental group, provides “Clean Bay Boating Kits.” Call them at 253-383-2429 to obtain a free kit.
- Check with marinas for other BMPs they have developed.
- Use one of the following treatment BMPs when paint chips or blasting grit are prevalent in the work area
  - Catch basin filter insert.
  - Infiltration basin.
  - Wet pond or vault.
  - Constructed wetland.
  - Vegetated biofilter.
  - Filtration with media designed for the pollutants that are present.
  - Or equivalent BMP, see Volume V.

## A7.4 LOGGING

**Description of Pollutant Sources:** This activity covers logging activities that fall under the Washington State Forest Practices Act category of Class IV general forest practices. These are situations where timber harvesting is done in the process of converting forest lands into other land uses, such as home and business construction. Stormwater runoff from bare ground can be loaded with dirt and other pollutants. This material can clog ditches and stream channels, thus reducing carrying capacity and increasing flooding, as well as smothering spawning beds for fish. Simply controlling runoff and not allowing it to leave the site will prevent these harmful effects. Clearing and grading activities are covered in detail in Volume II of this Manual, Construction Stormwater Pollution Prevention. Grading activities are also regulated in the City of Tacoma by the Grading and Excavation Code, Section 2.02.330 of the official code of the City of Tacoma.

An NPDES permit is needed from the Washington state Department of Ecology (Ecology) where five (5) or more acres of land is disturbed. Beginning in 2003, coverage under Ecology's General Permit will be required for construction sites that result in the disturbance of one acre or more of land. Compliance with the Construction Stormwater Pollution Prevention requirements in Ecology's manual is required, as applicable. Virtually all logging operations will require a permit from the Washington State Department of Natural Resources. Sensitive/critical areas and wetlands ordinances for Tacoma also contain requirements for logging activities in the vicinity of waterbodies.

Pollutants of concern include suspended solids, oils and greases, biochemical oxygen demand (BOD), nutrients, toxic organic compounds and heavy metals.

**Pollutant Control Approach:** Maintain required buffers adjacent to critical areas, including streams and wetlands. Keep sediments out of waterbodies and off paved areas.

### Required BMPs

- **Vegetation along stream corridors, and adjacent to other waterbodies and wetlands, must be preserved. Maintenance of a vegetated buffer enables filtration of most of the pollutants of concern for this activity. The above-mentioned ordinances contain specific requirements for buffer setbacks.**
- **Logging access roads must have a crushed rock or spall apron construction entrance where they join the pavement to prevent sediments from being tracked onto the pavement.**
- **On-site fueling and maintenance operations must follow the required BMPs as outlined in A2.4 Mobile Fueling, A2.3 Engine Repair and Maintenance and A.4.2 Storage of Liquid Chemicals, Waste Oils, Solvents or Petroleum Products in Portable Containers.**

## **Recommended BMPs**

The following BMPs are not required but can provide additional pollution protection:

- Erosion potential can be reduced by avoiding logging on steep slopes.
- If access roads are constructed for logging, they should be provided with drainage ditches that divert runoff into vegetated areas or stormwater treatment systems.
- Plant vegetated buffers in areas where they are already lost downslope of proposed logging areas, with sufficient lead time to allow for effective growth.



## **A7.5 MINING AND QUARRYING OF SAND, GRAVEL, ROCK, PEAT, CLAY AND OTHER MATERIALS**

**Description of Pollutant Sources:** This activity applies to surface excavation and on-site storage of sand, gravel and other materials that are mined. All mining operations that have stormwater runoff from the site are required to apply for a National Pollutant Discharge Elimination System (NPDES) permit with the Department of Ecology. Ecology has specific BMPs required by the permit. Some additional BMPs to help meet Ecology's discharge performance standards are listed below.

Pollutants of concern are suspended solids, nutrients, pH and metals.

**Pollutant Control Approach:** Provide containment and or cover for any on-site storage areas to prevent run-on and discharge of suspended solids and other pollutants.

### **Recommended BMPs**

The following BMPs are not required, but can be used to provide pollution protection in addition to other requirements:

- If the material is appropriate, use excavated spoil material to form compacted berms along downslope sides of the site to contain runoff. Berms should be seeded to promote growth of grass or other vegetation to limit erosion from the berms. Safety considerations must be examined to prevent flooding due to berm failure.
- Semi-permanent stockpiles should be seeded to promote vegetation growth to limit erosion from the stockpiles.
- Use detention ponds to promote settling of suspended solids, or infiltration basins to filter suspended solids, to clean up runoff before it leaves the site. Refer to Volume V for more information.
- Use anchored tarps to cover stockpiles at small-scale mining operations, if there is a potential for contaminated stormwater to leave the site.

## **A7.6 SWIMMING POOL AND SPA CLEANING AND MAINTENANCE**

**Description of Pollutant Sources:** This activity applies to all municipal and commercial swimming pools and spas, including Tacoma-Pierce County Health Department (TPCHD) regulated facilities. Pools and spas at hotels, motels, apartment and condominium complexes are covered here. Pools at single-family residences are covered in Chapter 3 of this BMP manual. Commercial pool and spa cleaning services must follow these required BMPs for all pools they service.

Pollutants of concern include nutrients, suspended solids, chlorine, pH and chemical oxygen demand (COD).

**Pollutant Control Approach:** Dispose of pool or spa water to the sanitary sewer.

### **Required BMPs**

- **The preferred method of pool or spa water disposal is to the sanitary sewer. If a sanitary sewer is available, all TPCHD regulated facilities are required to connect for draining and backwash. Contact the Tacoma Sanitary Source Control Unit at 253-591-5588 for specific instructions on allowable flow rates and timing before starting to drain the pool. Never discharge pool water to a septic system, as it will cause the system to fail.**
- **If discharge to the sanitary sewer is not possible, pool and spa water may be discharged to a ditch or storm drainage system provided that the water has been dechlorinated first. You are required to contact Tacoma Stormwater Source Control Unit at 253-591-5588 prior to discharge for instructions on allowable flow rates for the system or ditch that is being discharged to. Neutralizing chemicals are available for dechlorinating water. Letting the pool or spa "sit" may also reduce chlorine levels. Use a test kit to determine if the concentration has reached zero.**
- **State law allows discharges of pool water to the ground, not to a water body or storm drainage system, with a chlorine level of up to 3 parts per million. However, the water must not cross property lines or impact neighboring properties, and a satisfactory means for distributing the water to the ground must be used so there is no runoff.**
- **Diatomaceous earth used in pool filters cannot be discharged to surface waters, storm drainage systems, septic systems, or on the ground.**

### **Recommended BMPs**

The following BMPs are not required, but can provide additional pollution protection:

- Hire a professional pool-draining service to collect all pool water for offsite disposal.

## A7.7 DEICING AND ANTI-ICING OPERATIONS FOR AIRPORTS AND STREETS

**Description of Pollutant Sources:** Deicing and/or anti-icing compounds are used on highways, streets, airport runways, and on aircraft to control ice and snow. Typically ethylene glycol and propylene glycol are deicers used on aircraft. Deicers commonly used on highways and streets include calcium magnesium acetate (CMA), calcium chloride, magnesium chloride, sodium chloride, urea, and potassium acetate. The deicing and anti-icing compounds become pollutants when they are conveyed to storm drains or to surface water after application. Leaks and spills of these chemicals can also occur during their handling and storage.

### ***BMPs for Airport De/anti-icing Operations***

**Pollutant Control Approach for Aircraft:** Spent glycol discharges in aircraft application areas are process wastewaters that are regulated under Ecology's industrial stormwater general permit. (Contact the Ecology Regional Office for details.) BMPs for aircraft de/anti-icers must be consistent with aviation safety and the operational needs of the aircraft operator.

*EPA is currently studying airport deicing as part of the pretreatment regulations (40 CFR 403). These regulations are not expected to be promulgated for several years.*

### **Required BMPs for Aircraft:**

- **Conduct aircraft deicing or anti-icing applications in impervious containment areas. Collect aircraft deicer or anti-icer spent chemicals, such as glycol, draining from aircraft in deicing or anti-icing application areas and convey to a sanitary sewer, treatment, or other approved disposal or recovery method. Divert deicing runoff from paved gate areas to appropriate collection areas or conveyances for proper treatment or disposal.**
- **Do not allow spent deicer or anti-icer chemicals or stormwater contaminated with aircraft deicer or anti-icer chemicals to be discharged from application areas including gate areas, to surface water, or ground water, directly or indirectly.**
- **Transfer deicing and anti-icing chemicals on an impervious containment pad, or equivalent spill/leak containment area, and store in secondary containment areas. (See Storage of Liquids in Above-Ground Tanks)**

### **Recommended BMPs for Aircraft:**

- Establish a centralized aircraft de/anti-icing facility, if feasible and practicable, or in designated areas of the tarmac equipped with separate collection drains for the spent deicer liquids.
- Consider installing an aircraft de/anti-icing chemical recovery system, or contract with a chemical recycler, if practicable.

*Note the applicable containment BMP of aircraft de/anti-icing applications, and applicable treatment BMPs for de/anti-icer spent chemicals such as glycols.*

### **Required BMPs for Airport Runways/Taxiways:**

- **Avoid excessive application of all de/anti-icing chemicals, which could contaminate stormwater.**
- **Store and transfer de/anti-icing materials on an impervious containment pad or an equivalent containment area and/or under cover in accordance with BMP Storage or Transfer (Outside) of Solid Raw Materials, By-Products, or Finished Products in this volume. Other material storage and transfer approaches may be considered if it can be demonstrated that stormwater will not be contaminated with or that the de/anti-icer material cannot reach surface or ground waters.**

### **Recommended BMPs for Airport Runways/Taxiways:**

- Include limits on toxic materials and phosphorous in the specifications for de/anti-icers, where applicable.
- Consider using anti-icing materials rather than deicers if it will result in less adverse environmental impact.
- Select cost-effective de/anti-icers that cause the least adverse environmental impact.

### ***BMPs for Streets/Highways***

#### **Required BMPs for Streets/Highways**

- **Select de and anti-icers that cause the least adverse environmental impact. Apply only as needed using minimum quantities.**
- **Where feasible and practicable use roadway deicers, such as calcium magnesium acetate, potassium acetate, or similar materials, that cause less adverse environmental impact than urea, and sodium chloride.**
- **Store and transfer de/anti-icing materials on an impervious containment pad in accordance with BMP Storage or Transfer (Outside) of Solid Raw Materials, By-Products, or Finished Products in this volume.**
- **Sweep/clean up accumulated de/anti-icing materials and grit from roads as soon as possible after the road surface clears.**

#### **Recommended BMPs for Streets/Highways**

- Intensify roadway cleaning in early spring to help remove particulates from road surfaces.
- Include limits on toxic metals in the specifications for de/anti-icers.

## **A7.8 ROOF AND BUILDING DRAINS AT MANUFACTURING AND COMMERCIAL BUILDINGS**

**Description of Pollutant Sources:** Stormwater runoff from roofs and sides of manufacturing and commercial buildings can be sources of pollutants caused by leaching of roofing materials, building vents, and other air emission sources. Vapors and entrained liquid and solid droplets/particles have been identified as potential pollutants in roof/building runoff. Metals, solvents, acidic/alkaline pH, BOD, and organics, are some of the pollutant constituents identified.

**Pollutant Control Approach:** Evaluate the potential sources of stormwater pollutants and refer the business to the Puget Sound Clean Air Agency for the application of source control BMPs.

### **Required BMPs**

**These required source control BMPs will be addressed by the Puget Sound Clean Air Agency.**

- **If leachates and/or emissions from buildings are suspected sources of stormwater pollutants, then sample and analyze the stormwater draining from the building.**
- **If a roof/building stormwater pollutant source is identified, implement appropriate source control measures such as air pollution control equipment, selection of materials, operational changes, material recycle, process changes, etc.**

## A7.9 URBAN STREETS

**Description of Pollutant Sources:** Streets can be the sources of vegetative debris, paper, fine dust, vehicle liquids, tire wear residues, heavy metals (lead and zinc), soil particles, ice control salts, domestic wastes, lawn chemicals, and vehicle combustion products. Street surface contaminants have been found to contain significant concentrations of particle sizes less than 250 microns. (Sartor and Boyd, 1972)

**Pollutant Control Approach:** Conduct efficient street sweeping where and when appropriate to minimize the contamination of stormwater. Do not wash street debris into storm drains.

### Recommended BMPs

- For maximum stormwater pollutant reductions on curbed streets and high volume parking lots use efficient vacuum sweepers (refer to Volume V, Ch. 12 of this manual, for information about an emerging high-efficiency vacuum sweeper technology).

*Note: High-efficiency street sweepers utilize strong vacuums and the mechanical action of main and gutter brooms combined with an air filtration system that only returns clean air to the atmosphere (i.e., filters very fine particulates). They sweep dry and use no water since they do not emit any dust.*

*It has been reported that high-efficiency vacuum sweepers have the capability of removing, from pavements under good condition, 80 percent or more of the accumulated street dirt particles whose diameters are less than 250 microns. (Sutherland, 1998) This assumes pavements under good condition and reasonably expected accumulation conditions.*

- For moderate stormwater pollutant reductions on curbed streets use regenerative air sweepers or tandem sweeping operations.

*Note: A tandem sweeping operation involves a single pass of a mechanical sweeper followed immediately by a single pass of a vacuum sweeper or regenerative air sweeper.*

- *A regenerative air sweeper blows air down on the pavement to entrain particles and uses a return vacuum to transport the material to the hopper.*
- *These operations usually use water to control dust. This reduces their ability to pick up fine particulates.*

*It has been reported that these types of sweepers have the capability of removing approximately 25 to 50 percent of the accumulated street dirt particles whose diameters are less than 250 microns. (Sutherland, 1998) This assumes pavements under good conditions and typical accumulation conditions.*

- For minimal stormwater pollutant reductions on curbed streets use mechanical sweepers.
  - *Note: Mechanical sweepers are referred to as broom sweepers and use the mechanical action of main and gutter brooms to throw material on a conveyor belt that transports it to the hopper.*
  - *These sweepers usually use water to control dust. This reduces their ability to pick up fine particulates.*

*It has been reported that mechanical sweepers have the capability of removing only 10 to 20 percent of the accumulated street dirt particles whose diameters are less than 250 microns. (Sutherland, 1998) This assumes pavements under good condition and the most favorable accumulation conditions.*

- Conduct sweeping at optimal frequencies. Optimal frequencies are those scheduled sweeping intervals that produce the most cost-effective annual reduction of pollutants normally found in stormwater and can vary depending on land use, traffic volume and rainfall patterns.
- Train operators in those factors that result in optimal pollutant removal. These factors include sweeper speed, brush adjustment and rotation rate, sweeping pattern, maneuvering around parked vehicles, and interim storage and disposal methods.
- Consider the use of periodic parking restrictions in low to medium density single-family residential areas to ensure the sweeper's ability to sweep along the curb.
- Establish programs for prompt sweeping, removal, and disposal of debris from special events that will generate higher than normal loadings.
- Disposal of street sweeping solids must comply with "Recommendations for Management of Street Wastes" described in Appendix IV-C of this volume.
- Inform citizens about the importance of NOT putting yard debris, oil and other wastes in street gutters in order to reduce street pollutant sources.

## **A7.10 RAILROAD YARDS**

**Description of Pollutant Sources:** Pollutant sources can include drips/leaks of vehicle fluids onto the railroad bed, human waste disposal, litter, locomotive/railcar/equipment cleaning areas, fueling areas, outside material storage areas, the erosion and loss of soil particles from the railroad bed, maintenance and repair activities at railroad terminals, switching yards, and maintenance yards, and herbicides used for vegetation management. Waste materials can include waste oil, solvents, degreasers, antifreeze solutions, radiator flush, acids, brake fluids, soiled rags, oil filters, sulfuric acid and battery sludges, and machine chips with residual machining oil and toxic fluids/solids lost during transit. Potential pollutants include oil and grease, TSS, BOD, organics, pesticides, and metals.

**Pollutant Control Approach:** Apply good housekeeping and preventive maintenance practices to control leaks and spills of liquids in railroad yard areas.

### **Required BMPs**

- **Implement the applicable BMPs in this chapter depending on the pollutant generating activities/sources at a railroad yard facility.**
- **Do not allow discharge to outside areas from toilets while a train is in transit. Pumpout facilities should be used to service these units.**
- **Use drip pans at hose/pipe connections during liquid transfer and other leak-prone areas.**
- **During maintenance do not discard debris or waste liquids along the tracks or in railroad yards.**

**In areas subjected to leaks/spills of oils or other chemicals convey the contaminated stormwater to appropriate treatment such as a sanitary sewer, if approved by the City of Tacoma, or, to a CP or API oil/water separator for floating oils, or other appropriate treatment BMP. See Volume V.**



## **A7.11 MAINTENANCE OF PUBLIC AND UTILITY CORRIDORS AND FACILITIES**

**Description of Pollutant Sources:** Passageways and equipment at petroleum product, natural gas, and water pipelines, and electrical power transmission corridors and rights-of-way can be sources of pollutants such as herbicides used for vegetation management, and eroded soil particles from unpaved access roads. At pump stations waste materials generated during maintenance activities may be temporarily stored outside. Additional potential pollutant sources include the leaching of preservatives from wood utility poles, PCBs in older transformers, water that is removed from underground transformer vaults, and leaks/spills from petroleum pipelines. The following are potential pollutants: oil and grease, TSS, BOD, organics, PCB, pesticides, and heavy metals.

**Pollutant Control Approach:** Control of fertilizer and pesticide applications, soil erosion, and site debris that can contaminate stormwater.

### **Required BMPs**

- **Implement BMPs included in Chapter 4, A.9 Landscaping and Lawn/Vegetation Management and in Chapter 6, Section 6.2, R.6, Pesticide Regulations.**
- **When water or sediments are removed from electric transformer vaults, determine whether contaminants might be present before disposing of the water and sediments. This includes inspecting for the presence of oil or sheen, and determining from records or testing if the transformers contain PCBs. If records or tests indicate that the sediment or water are contaminated above applicable levels, manage these media in accordance with applicable federal and state regulations, including the federal PCB rules (40 CFR 761) and the state MTCA cleanup regulations (Chapter 173-340 WAC). Water removed from the vaults can be discharged in accordance with the federal 40 CFR 761.79, and state regulations (Chapter 173-201A WAC and Chapter 173-200 WAC), or via the sanitary sewer if the requirements, including applicable permits, for such a discharge are met. (See also Chapter 6, Section 6.2-R2).**
- **Within utility corridors, consider preparing maintenance procedures and an implementation schedule that provides for vegetative, gravel, or equivalent cover that minimizes bare or thinly vegetated ground surfaces within the corridor, to prevent the erosion of soil.**
- **Provide maintenance practices to prevent stormwater from accumulating and draining across and/or onto roadways. Stormwater should be conveyed through roadside ditches and culverts. The road should be crowned, outsloped, water barred or otherwise left in a condition not conducive to erosion. Appropriately maintaining grassy roadside ditches discharging to surface waters is an effective way of removing some pollutants associated with sediments carried by stormwater.**
- **Maintain ditches and culverts at an appropriate frequency to ensure that plugging and flooding across the roadbed, with resulting overflow erosion, does not occur.**
- **Apply the appropriate BMPs from Section A4 of this Volume, Storage Activities, for the storage of waste materials that can contaminate stormwater.**

## **Recommended BMPs**

- When selecting utility poles for a specific location, consideration should be given to the potential environmental effects of the pole or poles during storage, handling, and end-use, as well as its cost, safety, efficacy and expected life. If a wood product treated with chemical preservatives is used, it should be made in accordance with generally accepted industry standards such as the American Wood Preservers Association Standards. If the pole or poles will be placed in or near an environmentally sensitive area, such as a wetland or a drinking water well, alternative materials or technologies should be considered. These include poles constructed with material(s) other than wood such as fiberglass composites, metal, or concrete. Other technologies and materials, such as sleeves or caissons for wood poles, may also be considered when they are determined to be practicable and available.
- As soon as practicable remove all litter from wire cutting/replacing operations, etc.
- Implement temporary erosion and sediment control in areas where clear-cuts are conducted and new roads are constructed.

## **A7.12 MAINTENANCE OF ROADSIDE DITCHES**

**Description of Pollutant Sources:** Common road debris including eroded soil, oils, vegetative particles, and heavy metals can be sources of stormwater pollutants.

**Pollutant Control Approach:** Roadside ditches should be maintained to preserve the condition and capacity for which they were originally constructed, and to minimize bare or thinly vegetated ground surfaces. Maintenance practices should provide for erosion and sediment control (Refer to Activity A3.6 Landscaping and Lawn/Vegetation Management).

### **Required BMPs**

- **Inspect roadside ditches regularly, as needed, to identify sediment accumulations and localized erosion.**
- **Clean ditches on a regular basis, as needed. Ditches should be kept free of rubbish and debris.**
- **Vegetation in ditches often prevents erosion and cleanses runoff waters. Remove vegetation only when flow is blocked or excess sediments have accumulated. Conduct ditch maintenance (seeding, fertilizer application, harvesting) in late spring and/or early fall, where possible. This allows vegetative cover to be re-established by the next wet season thereby minimizing erosion of the ditch as well as making the ditch effective as a biofilter.**
- **In the area between the edge of the pavement and the bottom of the ditch, commonly known as the “bare earth zone,” use grass vegetation, wherever possible. Vegetation should be established from the edge of the pavement if possible, or at least from the top of the slope of the ditch.**
- **Diversion ditches on top of cut slopes, that are constructed to prevent slope erosion by intercepting surface drainage, must be maintained to retain their diversion shape and capability.**
- **Ditch cleanings are not to be left on the roadway surfaces. Sweep dirt and debris remaining on the pavement at the completion of ditch cleaning operations.**
- **Roadside ditch cleanings, not contaminated by spills or other releases and not associated with a stormwater treatment system such as a bioswale, may be screened to remove litter and separated into soil and vegetative matter (leaves, grass, needles, branches, etc.). The soil fraction may be handled as ‘clean soils’ and the vegetative matter can be composted or disposed of in a municipal waste landfill. For more information, please see “Recommendations for Management of Street Wastes,” in Appendix IV-D of this volume.**
- **Roadside ditch cleanings contaminated by spills or other releases known or suspected to contain dangerous waste must be handled following the Dangerous Waste Regulations (Chapter 173-303 WAC) unless testing determines it is not dangerous waste.**

- **Inspect culverts on a regular basis for scour or sedimentation at the inlet and outlet, and repair as necessary. Give priority to those culverts conveying perennial and/or salmon-bearing streams and culverts near streams in areas of high sediment load, such as those near subdivisions during construction.**

#### **Recommended BMPs**

- Install biofiltration swales and filter strips to treat roadside runoff wherever practicable and use engineered topsoils wherever necessary to maintain adequate vegetation (CH2M Hill, 2000). These systems can improve infiltration and stormwater pollutant control upstream of roadside ditches. Refer to Volume 5 of this manual, Runoff Treatment BMPs for additional information about biofiltration swales and filter strips.

## **A7.13 MAINTENANCE OF STORMWATER DRAINAGE AND TREATMENT FACILITIES**

**Description of Pollutant Sources:** Facilities include roadside catch basins on arterials and within residential areas, conveyance systems, detention facilities such as ponds and vaults, oil and water separators, biofilters, settling basins, infiltration systems, and all other types of stormwater treatment systems presented in Volume V. Roadside catch basins can remove from 5 to 15 percent of the pollutants present in stormwater. When catch basins are about 60 percent full of sediment, they cease removing sediments. Oil and grease, hydrocarbons, debris, heavy metals, sediments and contaminated water are found in catch basins, oil and water separators, settling basins, etc.

**Pollutant Control Approach:** Provide maintenance and cleaning of debris, sediments, and oil from stormwater collection, conveyance, and treatment systems to obtain proper operation.

### **Required BMPs**

**Maintain stormwater treatment facilities according to the O & M procedures presented in Section 4.6 of Volume V of this manual, in addition to the following BMPs:**

- **Inspect and clean treatment BMPs, conveyance systems, and catch basins as needed, and determine whether improvements in O & M are needed.**
- **Promptly repair any deterioration threatening the structural integrity of the facilities. These include replacement of clean-out gates, catch basin lids, and rock in emergency spillways.**
- **Ensure that storm sewer capacities are not exceeded and that heavy sediment discharges to the sewer system are prevented.**
- **Regularly remove debris and sludge from BMPs used for peak-rate control, treatment, etc. and discharge to a sanitary sewer if approved by the City of Tacoma, or truck to a local or state government approved disposal site.**
- **Clean catch basins in accordance with the information provided in Volume V, Runoff Treatment BMPs, Section 4.6, number 5. Additional information is also included in Chapter 5 of this volume, BMP S.9 Cleaning Catch Basins.**
- **Clean woody debris in a catch basin as frequently as needed to ensure proper operation of the catchbasin.**
- **Post warning signs; “Dump No Waste - Drains to Ground Water,” “Streams,” “Lakes,” or emboss on or adjacent to all storm drain inlets *where practical*.**
- **Disposal of sediments and liquids from the catch basins must comply with “Recommendations for Management of Street Wastes” described in Appendix IV-D of this volume.**

- **Select additional applicable BMPs from this chapter depending on the pollutant sources and activities conducted at the facility. Those BMPs include:**
  - **A4.7 - BMPs for Storage of Liquid, Food Waste, or Dangerous Waste Containers**
  - **A6.3 - BMPs for Soil Erosion and Sediment Control at Industrial Sites**
  - **A7.9 - BMPs for Urban Streets**
  - **A7.14 - BMPs for Spills of Oil and Hazardous Substances**
  - **S1 - BMPs for Illicit Connections to Storm Drains**

## **A7.14 SPILLS OF OIL AND HAZARDOUS SUBSTANCES**

**Description of Pollutant Sources:** Owners or operators of facilities engaged in drilling, producing, gathering, storing, processing, transferring, distributing, refining or consuming oil and/or oil products are required by Federal Law to have a Spill Prevention and Control Plan if the storage capacity of the facility, which is not buried, is 1,320 gallons or more of oil, or any single container with a capacity in excess of 660 gallons and which, due to their location, could reasonably be expected to discharge oil in harmful quantities, as defined in 40 CFR Part 110, into or upon the navigable waters of the United States or adjoining shorelines {40 CFR 112.1 (b)}. Onshore and offshore facilities, which, due to their location, could not reasonably be expected to discharge oil into or upon the navigable waters of the United States or adjoining shorelines are exempt from these regulations {40 CFR 112.1(1)(i)}. Owners of businesses that produce Dangerous Wastes are also required by State Law to have a spill control plan. These businesses should refer to Chapter 6, Section 6.2, R-2. The federal definition of oil is oil of any kind or any form, including, but not limited to petroleum, fuel oil, sludge, oil refuse, and oil mixed with wastes other than dredged spoil.

**Pollutant Control Approach:** Maintain, update, and implement an oil spill prevention/cleanup plan.

### **Required BMPs**

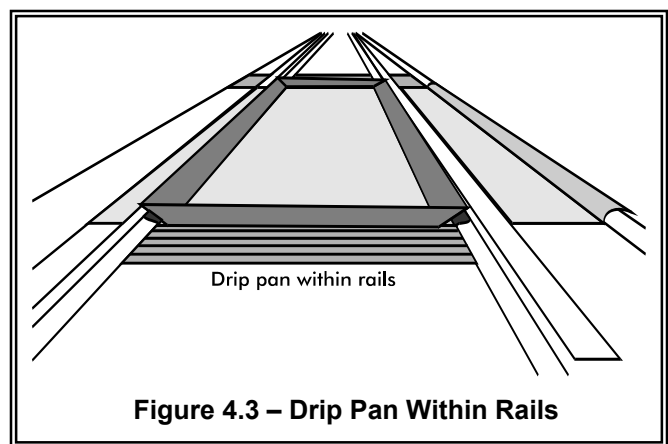
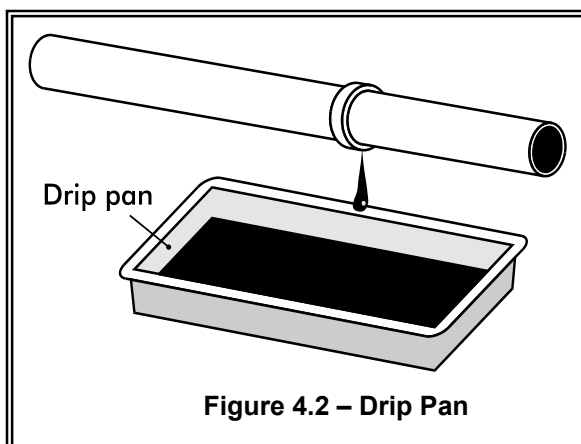
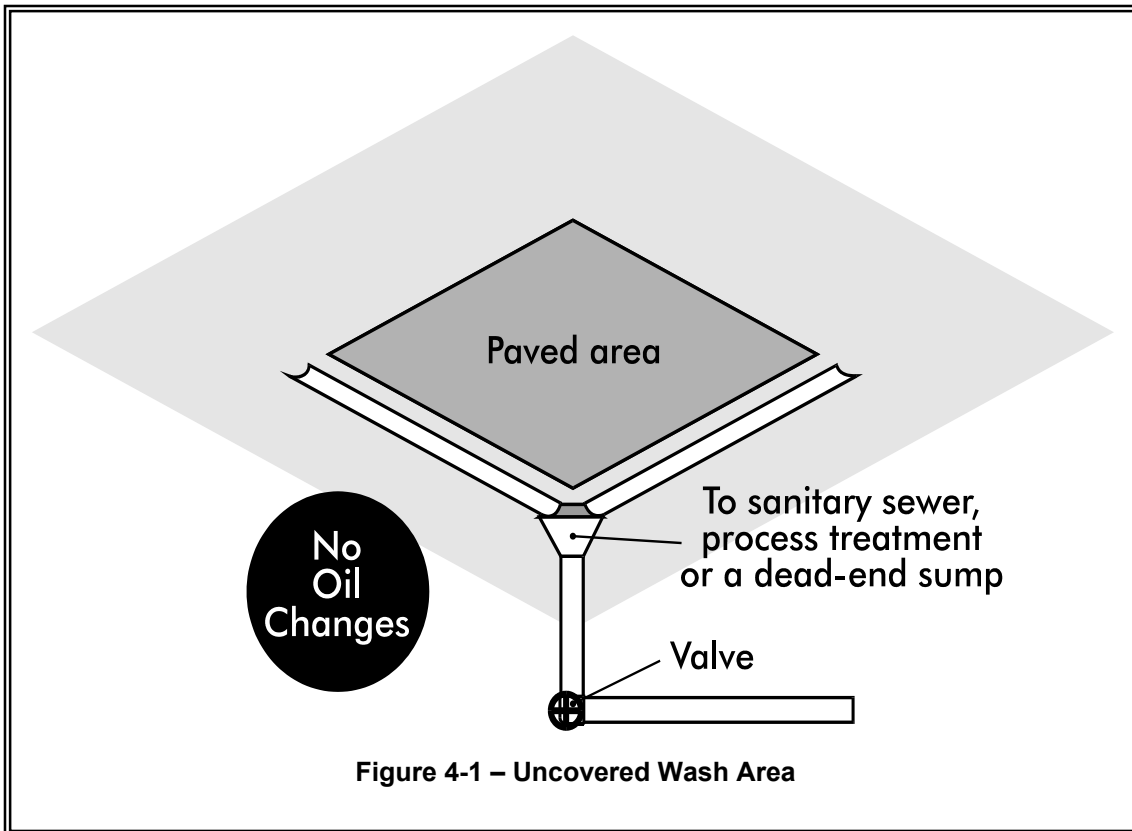
- **Prepare an Emergency Spill Control Plan (SCP), which includes:**
  - **A description of the facility including the owner's name and address;**
  - **The nature of the activity at the facility;**
  - **The general types of chemicals used or stored at the facility;**
  - **A site plan showing the location of storage areas for chemicals, the locations of storm drains, the areas draining to them, and the location and description of any devices to stop spills from leaving the site such as positive control valves;**
  - **Cleanup procedures;**
  - **Notification procedures to be used in the event of a spill, such as notifying key personnel. Agencies such as Ecology, Tacoma Fire Department, Washington State Patrol, City of Tacoma, U.S. Coast Guard and the U.S. Environmental Protection Agency shall be notified;**
  - **The name of the designated person with overall spill cleanup and notification responsibility;**
  
- **Train key personnel in the implementation of the Emergency SCP. Prepare a summary of the plan and post it at appropriate points in the building, identifying the spill cleanup coordinators, location of cleanup kits, and phone numbers of regulatory agencies to be contacted in the event of a spill;**
  
- **Update the SCP regularly;**
  
- **Immediately notify Ecology and the City of Tacoma if a spill may reach sanitary or storm sewers, ground water, or surface water, in accordance with federal and Ecology spill reporting requirements;**
  
- **Immediately clean up spills. Do not use emulsifiers for cleanup unless an appropriate disposal method for the resulting oily wastewater is implemented. Absorbent material shall not be washed down a floor drain or storm sewer; and,**

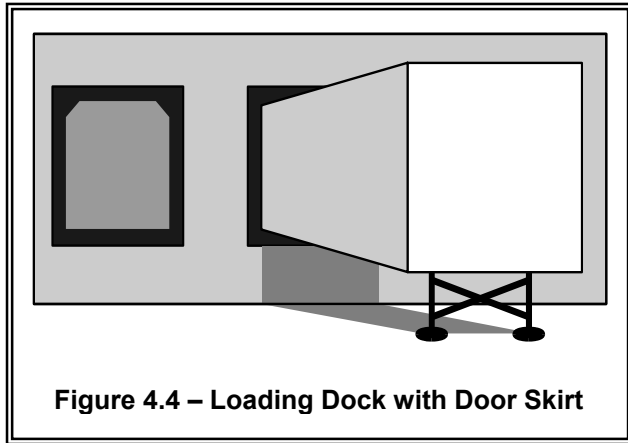
- **Locate emergency spill containment and cleanup kit(s) in high potential spill areas. The contents of the kit shall be appropriate for the type and quantities of chemical liquids stored at the facility.**

#### **Recommended BMP**

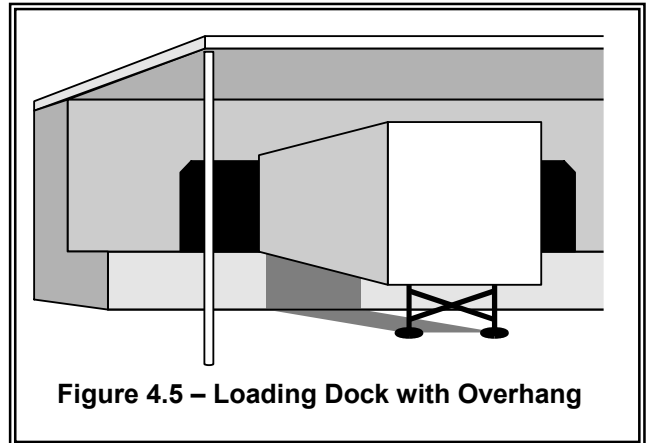
- Spill kits should include appropriately lined drums, absorbent pads, and granular or powdered materials for neutralizing acids or alkaline liquids where applicable. In fueling areas: absorbent should be packaged in small bags for easy use and small drums should be available for storage of absorbent and/or used absorbent. Spill kits should be deployed in a manner that allows rapid access and use by employees.



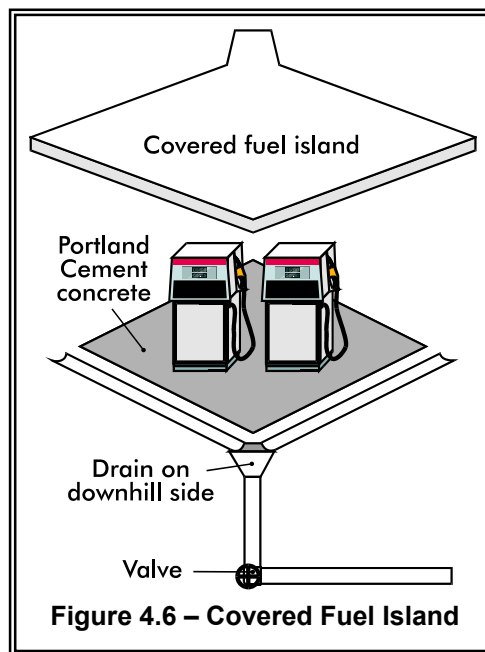




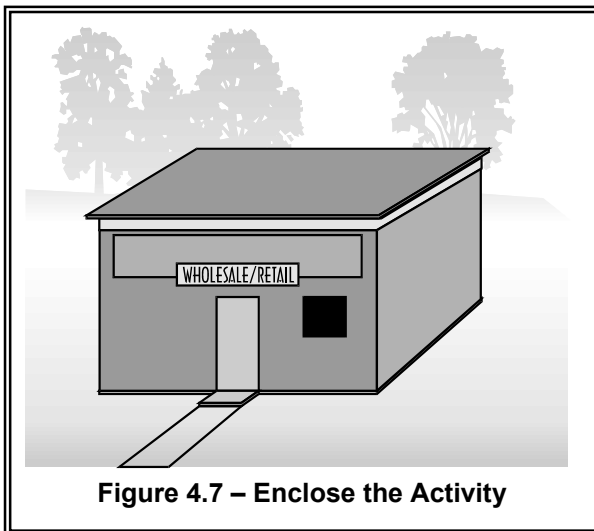
**Figure 4.4 – Loading Dock with Door Skirt**



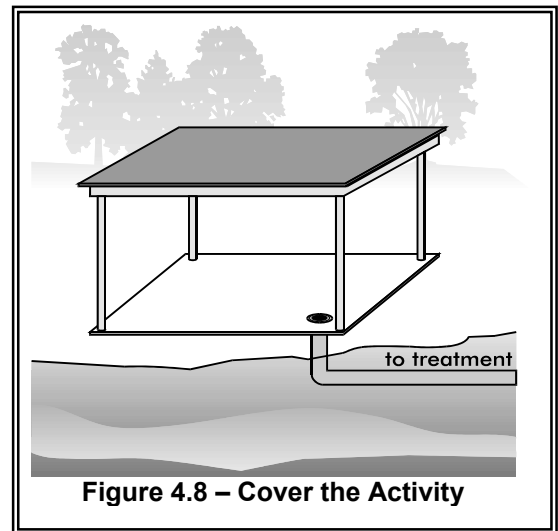
**Figure 4.5 – Loading Dock with Overhang**



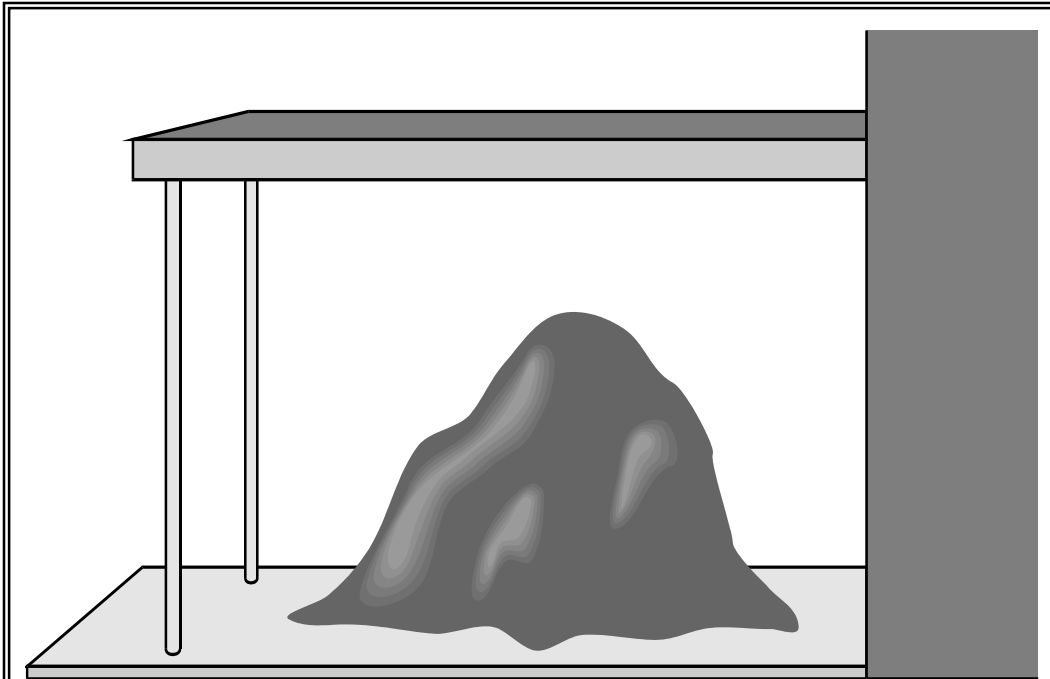
**Figure 4.6 – Covered Fuel Island**



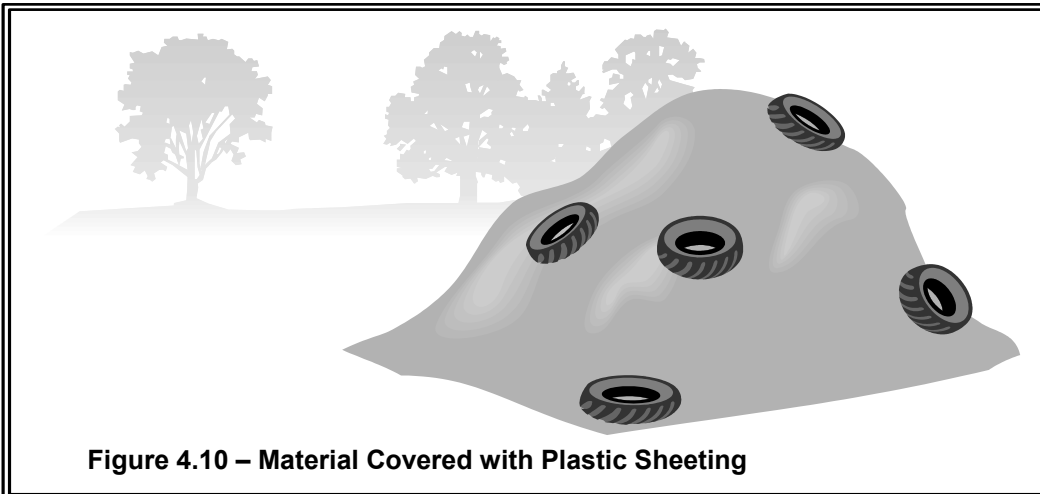
**Figure 4.7 – Enclose the Activity**



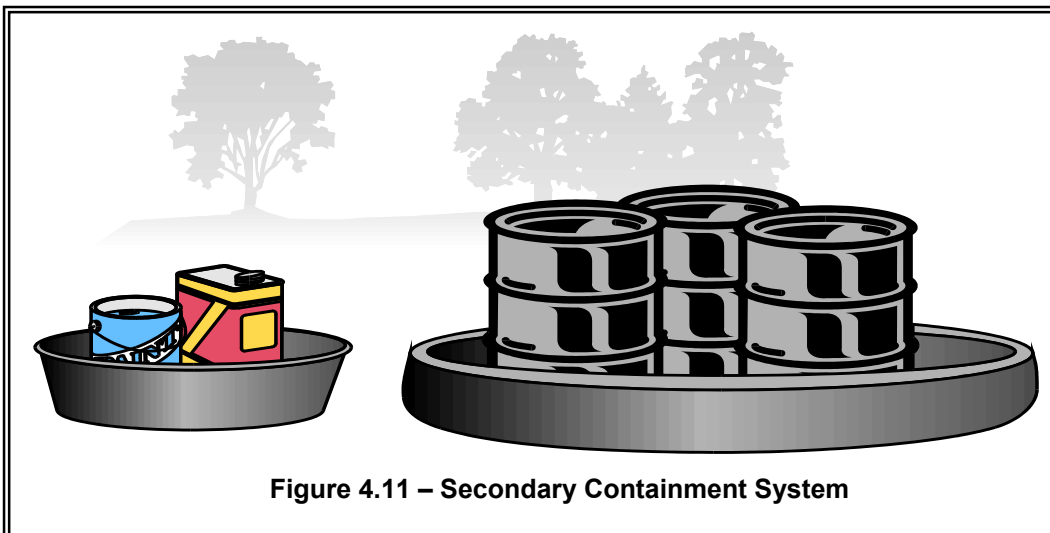
**Figure 4.8 – Cover the Activity**



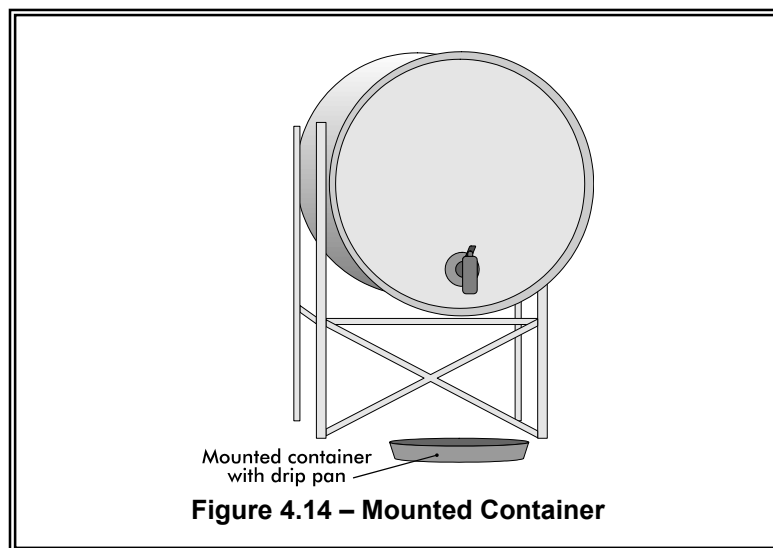
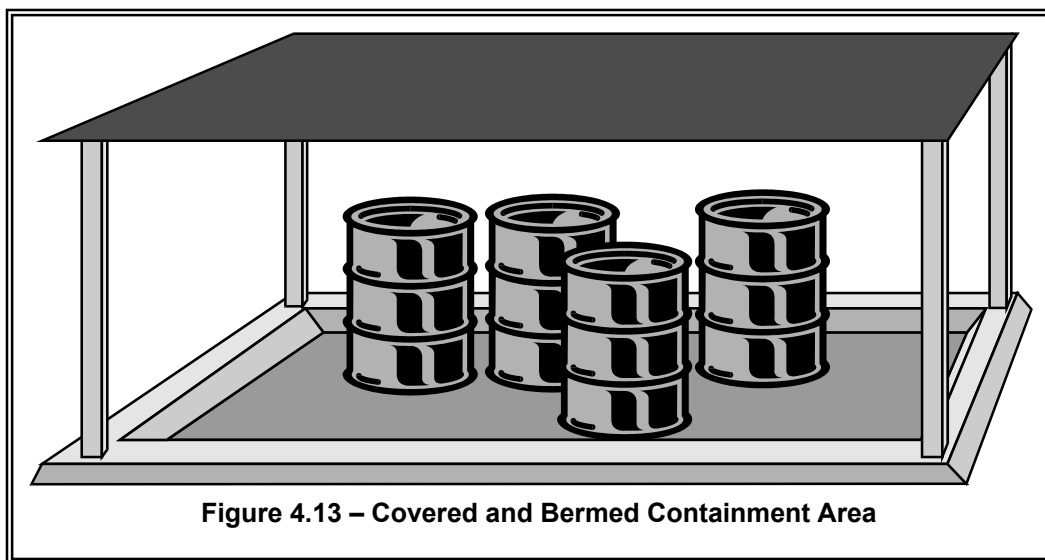
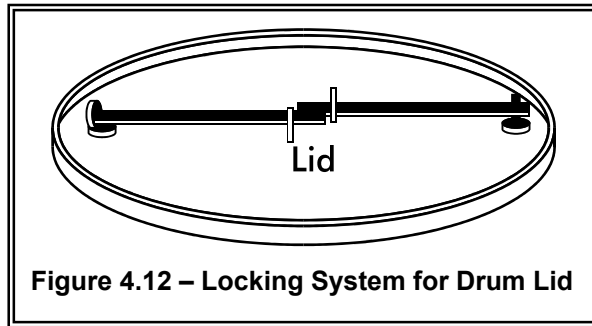
**Figure 4.9 – Covered Storage Area for Bulk Solids (include berm if needed)**

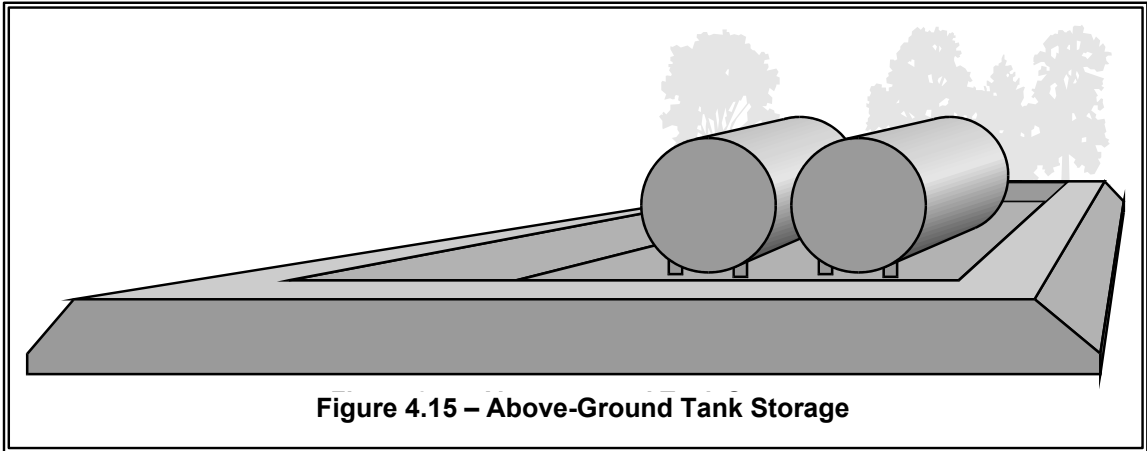


**Figure 4.10 – Material Covered with Plastic Sheeting**



**Figure 4.11 – Secondary Containment System**





# Chapter 5 – Source Control Best Management Practices

---

In the previous chapter, different commercial activities were described and BMPs for pollution prevention were listed. This chapter provides the detailed descriptions of those source control BMPs.

Section 4.3, BMPs to Consider for All Activities, provides a list of general BMPs that each business should consider. Most of these are common sense, housekeeping types of activities, such as spill cleanup, moving activities indoors, and using the least toxic materials available. The implementation of these types of BMPs will help improve water quality.

## 5.1 Index of BMP Descriptions

<b>BMP</b>	<b>DESCRIPTION TITLE</b>
<b>S.1</b>	Eliminate illicit storm drainage system connections
<b>S.2</b>	Dispose of collected runoff and waste materials properly
<b>S.3</b>	Connect process water discharges to a sanitary sewer, holding tank, or water treatment system
<b>S.4</b>	Cover the activity with a roof or awning
<b>S.5</b>	Cover the activity with an anchored tarp or plastic sheet
<b>S.6</b>	Pave the activity area and slope to a sump or holding tank
<b>S.7</b>	Surround the activity area with a curb, dike or berm, or elevate the activity
<b>S.8</b>	Implement integrated pest management measures
<b>S.9</b>	Clean catch basin

## 5.2 Source Control BMPs

### BMP S.1 ELIMINATE ILLICIT STORM DRAIN CONNECTIONS

A common problem with the storm drain system for Tacoma is the existence of illegal hook-ups to the system. Many businesses and residences hooked internal building drains, sump overflows, process wastewater discharges and even sanitary sewer and septic system pipes to the storm drain in the past as a matter of course. These connections allow a variety of pollutants to flow directly to receiving waters instead of to the sanitary sewer or septic system. Frequently, these connections are unknown to the current owner, and do not appear on any plans for the site. Because of the potential to pollute that these connections represent, the Environmental Protection Agency, under the mandate of the National Pollutant Discharge Elimination System (NPDES) stormwater permits, has made the elimination of such illicit connections a top priority.

All businesses and residences in Tacoma must examine their plumbing systems to determine if illicit connections exist. A good place to start would be with site plans. This will help the current owner understand what piping systems were installed initially, making piping that does not appear on the plan a priority for investigation. Any time it is found that toilets, sinks, appliances, showers and bathtubs, floor drains, industrial process waters and all other indoor activities are connected to the storm drainage system, these connections must either be immediately rerouted to the sanitary or septic system, holding tanks, or process treatment system. Exceptions to this requirement would be those industries and businesses that have been issued an NPDES Baseline General Permit by Ecology, and are allowed specific discharges under that permit. Please refer to R.4 in Chapter 6 to determine if your type of business is required to have a NPDES permit.

If it is found that sanitary facilities, such as toilets, are hooked to the storm drain system, you must have permits from your local sewer utility (Tacoma 253-591-5588) to reroute them to the sanitary sewer. If sanitary service is not available, contact the City of Tacoma for a septic permit.

Dye testing with a non-toxic dye is one way of helping to determine where a pipe or structure drains to if it is not obvious by observations or on plans. The dye is put into the structure and flushed with some water. Observations are then made at ends-of-pipes, drainage ditches, catch basins and manholes to look for the color coming through. Contact the Tacoma Source Control Unit at 253-591-5588 if you need assistance in locating city structures adjacent to your property.

Smoke testing can also be used to detect illicit connections. It is typically best done by qualified personnel. All indoor discharges should be shut off before this test is conducted. A smoke bomb or other smoke-generating device is placed in a storm drain manhole, and air is forced in after it. Personnel should be stationed at each suspect drain location to observe if smoke is coming out. Smoking drains should be tagged for future rerouting.

Drains which are found to connect to the storm drainage system must either be permanently plugged or disconnected and rerouted as soon as possible. Drains that are no longer needed can be plugged with concrete or similarly effective permanent materials. If a drain pipe is to be rerouted and a sanitary sewer services the property, then the local sewer district must be contacted. Contact the number listed above for specific directions prior to rerouting. Restrictions on certain types of discharges, particularly industrial process waters, may require pretreatment of discharges before entering the sanitary sewer. It is the responsibility of the property owner or

business operator to follow through on rerouting illicit storm drainage connections to the sanitary sewer.

If the property is not served by a sanitary sewer, alternate measures will be necessary. If the discharge is simply domestic waste, a septic system may be feasible. If it is necessary to install a septic system, the proper permits will need to be obtained from the Tacoma-Pierce County Health Department at 253-798-6470. If the discharge is anything other than domestic waste, then a holding tank or on-site treatment will be necessary. Contact the Tacoma Sanitary Source Control unit at 253-591-5588 for specific directions for installation and disposal.



## **BMP S.2 DISPOSE OF COLLECTED RUNOFF AND WASTE MATERIALS PROPERLY**

Every business and residence in Tacoma must dispose of solid and liquid wastes and contaminated stormwater properly. There are generally four options for disposal depending on the type of materials. These options include:

- Sanitary sewer and septic systems
- Recycling facilities
- Municipal solid waste disposal facilities
- Hazardous waste treatment, storage, and disposal facilities

Many liquid wastes and contaminated stormwater (depending on the pollutants and associated concentrations present) can be put into the sanitary sewer, subject to approval by the local sanitary sewer district. Animal wastes can also be disposed of in a sanitary sewer, subject to loading capacity constraints.

If wastes cannot be legally discharged to a sanitary sewer or septic system, one of the other three disposal options must be used. Sumps or holding tanks may be useful for storing liquid wastes temporarily. The contents must be disposed of in the sanitary sewer or at a dangerous waste facility depending on the nature of the waste.

Recycling facilities are a recommended option for many commercial and household items, including used oils, used batteries, old equipment, glass, some plastics, metal scrap materials, solvents, paints, wood and land clearing wastes, and various other solid wastes. Solid wastes that cannot be recycled and that are not hazardous must be disposed of at a licensed municipal solid waste disposal facility. The list in Chapter 7 of this manual has the phone numbers and addresses of these facilities in Tacoma.

Dangerous and hazardous wastes must be properly transported to an appropriate hazardous waste disposal, treatment and storage facility. Included in Chapter 7 is a list of companies dealing in these activities.

Costs of disposal vary considerably from option to option. Especially in the case of dangerous wastes, the different types of wastes should be kept segregated. Disposal costs are usually determined by the most hazardous or difficult to dispose of waste present, so you can keep your costs down by not mixing wastes. The Tacoma-Pierce County Health Department Hazardous Waste section at 798-6047 can help you determine the best disposal options for your waste.

### **BMP S.3      CONNECT PROCESS WATER DISCHARGES TO A SANITARY SEWER, HOLDING TANK, OR WASTEWATER TREATMENT SYSTEM**

This BMP is a minimum requirement for all industrial and commercial activities that generate contaminated process wastewater, such as washing activities, composting activities, and production and processing activities. The water used in these activities cannot drain to surface waters or groundwater untreated. Process water must drain to a sanitary sewer, holding tank, or wastewater treatment system, or it can be recycled.

The first priority for these businesses is discharge of process water to a sanitary sewer via a new or existing plumbing connection. In order to connect to the sewer, you must contact Tacoma Building and Land Use Services at 591-5030 for information on permits for the connection. Pretreatment of industrial wastewaters will often be necessary before it is allowed to discharge to the sewer. Call Tacoma Sanitary Source Control Unit at 591-5588 for more information.

If a sanitary sewer is not available, or if it is determined that a discharge connection is not allowed, the only remaining options are holding tanks or an on-site wastewater treatment facility. Consideration should be given to using a holding tank for used process water if the volume of process water generated by the activity is not excessive. The contents of the holding tank must be pumped out or drained before the tank is full and disposed of properly (see BMP S.2 in this chapter for information on disposal options). If a sanitary sewer connection cannot be made and a holding tank is not used, a wastewater treatment facility must be constructed on the site. This treatment facility must be designed to receive and effectively treat all discharges of process water from the business. The Washington State Department of Ecology must be contacted for approval of such a facility, since discharges from the treatment facility will enter surface waters or be spread on land. See Chapter 6 for Ecology's requirements for discharges of process waters.

For all types of process water discharges the following measures are required if the activity is to remain uncovered. Define a designated area for the activity and provide a mechanism for prevention of stormwater run-on into the activity area. This can be a curb, dike or berm (see BMP S.7 in this chapter for more information) or similar effective means to prevent run-on. In this manner, only the precipitation that falls within the activity area is discharged and/or treated along with the activity process water. The designated area should be paved and sloped to a central collection drain. The collection drain must connect to the sanitary sewer (with pretreatment if required), the on-site holding tank, or the on-site treatment facility, whichever method is selected.

This process water BMP can be made more effective if the activity is covered, thus reducing the total amount of water to be treated.

#### **BMP S.4 COVER THE ACTIVITY WITH A ROOF OR AWNING**

Not every activity can or needs to be located inside a building. In many cases, a simple roof or awning will protect the activity from coming into contact with stormwater, and usually at a lower cost than a complete building. If you do decide to build one of these structures, you will need to obtain permits from the Tacoma Building and Land Use Services Division at 591-5030. They will also be able to help you with fire code requirements and zoning code provisions.

The roof structure can be designed in several ways. One option is a lean-to type of structure, where sheets of corrugated steel, fiberglass, aluminum or similar impermeable material are attached to the wall of a building and are supported by sturdy poles. Similarly, if there is no building to attach to, roofing materials can be sufficiently supported at all four corners as a stand alone cap, or a waterproof tent canopy can be used.

The area of the roof cover should be sufficient to prevent any precipitation from reaching the covered materials. Examples of these types of structures are shown in Figure 5.1.

Another option for covering an activity is to use an overhanging awning of sufficient size to prevent rain from reaching the materials. Many of the building permit, fire code and zoning requirements will also apply to these structures. An example of an awning cover is shown in Figure 5.2.

Activities such as fueling operations may be more conveniently covered by an island-type overhanging roof. This type of roof is supported by columns along the center of the structure rather than at the corners, enabling vehicles easy access underneath while still providing sufficient protection from rain. An example of this type of roof structure is shown in Figure 5.2.

Note that floating fuel stations (such as some used for refueling boats) cannot be covered, according to the fire code.

The particular roof cover option used at a given site is subject to the site layout and available space, affordability, and limitations imposed by other regulations. Structural cover options other than those given above can be used if they perform the same function. This BMP should usually be implemented in conjunction with sump or sanitary sewer drains and provisions for prevention of stormwater run-on into the covered area. BMPs S.6 and S.7 in this chapter present information on sump installation and run-on prevention.

## **BMP S.5      COVER THE ACTIVITY WITH AN ANCHORED TARP OR PLASTIC SHEET**

Some activities, such as stockpiling of raw materials, can be effectively covered with a sturdy tarp or heavy plastic sheet made of impermeable material. Weights such as bricks, tires, or sandbags should be used to anchor the cover in place. Care should be taken to ensure that the tarp or sheet covers the activity completely and that stormwater run-on does not penetrate significantly under the cover. If several sheets are used to form a cover, the sheets should be tethered together or laid in an overlapping manner. If necessary, pins or stakes should be used to anchor the tarp to the ground. The tarp must be inspected daily to ensure that no holes or gaps are present in the tarp coverage. An example of this type of cover is shown in Figure 5.3.

The tarp covering will be easier to keep in place and will last longer if some form of wind protection is possible. Attempts should be made to locate stockpiles adjacent to buildings where winds are reduced, but not in between buildings where a wind tunnel effect can occur

Tarps are an inexpensive and cost effective BMP for many activities. This BMP can be combined with runoff containment/run-on prevention curbs, dikes, and berms for better effectiveness (see BMP S.7 for more information).

## **BMP S.6      PAVE THE ACTIVITY AREA AND SLOPE TO A SUMP OR HOLDING TANK**

This BMP applies to several activities that cannot be covered effectively. It is particularly suited to activities with the potential for leaks and spills, but that otherwise do not generate excessive amounts of polluted runoff. Examples are storage of liquid chemicals, waste oils, and solvents in portable containers such as drums; loading and unloading of liquids from trucks; and painting, finishing and coating activities. A sump or holding tank serves to provide spill containment until the liquids can be pumped out and properly disposed. If the activity produces large amounts of runoff, this BMP will not be very effective because the stray contaminants will overflow the sump or pass through the sump before collection and disposal are possible. To prevent run-on, the area should be enclosed with a berm, curb, or dike as shown in Figure 5.5, Containment Types. The following implementation information is intended for situations where this BMP can be effective.

A designated activity area should be paved and sloped to drain to a central collection point. A sump, vault, or holding tank should be installed underneath this collection drain. Some materials, such as gasoline, can react with asphalt pavement and break it down, releasing additional pollutants. If the area is not yet paved and materials are present which may react with asphalt, the area must be paved with concrete. If the area is already paved with asphalt, an asphalt sealant can be applied which can aid in preventing pavement degradation. Whichever paving material is used, the paved surface must be free of gaps and cracks.

The sump or holding tank should have a capacity large enough to contain the entire volume of a potential spill. An example of a paved activity area with a sump drain is shown in Figure 5.4.

Wash pads may frequently need to use a sump arrangement like this. To keep disposal costs down, a drain cover, plug or shutoff valve upstream of the sump should be used at times when the activity is not occurring.

The cost of constructing a sump and the disposal of accumulated contents can be high, so businesses should consider whether other allowable alternative BMPs can be used.

Commercial services that pump sumps and holding tanks are listed in the Yellow Pages of the phone directory under Environmental and Ecological Services.

BMPs S.4, S.5 and S.7 in this chapter present information on covering activities and run-on prevention.

## **BMP S.7      SURROUND THE ACTIVITY AREA WITH A CURB, BERM, OR DIKE, OR ELEVATE THE ACTIVITY**

This set of BMP options can be an effective means for prevention of stormwater run-on to an activity area. In addition, a curb, berm or dike can be used for containment of spills in the activity area, or for containment of contaminated activity runoff. Generally, a containment BMP is most applicable to spill control situations; that is, sites where runoff is relatively clean, but occasional spills may occur. This BMP may be less expensive to implement than paving the activity area and providing proper drainage collection, but can also be more difficult to maintain if stormwater ponding occurs inside a containment dike.

If a curb, dike or berm is used to prevent stormwater run-on to a covered activity area, and the activity area is paved or otherwise impermeable, the berm should be placed underneath the covering so that rain will not pond inside it. Stormwater run-on can also be prevented by elevating the activity with a platform or other type of pedestal.

Containment may be achieved with concrete curbing, an earthen berm, a tub such as a plastic wading pool, or some other dike material, depending on the activity, its size, and resources available. Activities that require more space and therefore cannot be contained with a tub may need to be surrounded by a curb, dike, or berm. Aboveground storage tanks of liquids, storage of chemicals or wastes in numerous drums, and stockpiling of fertilizer are examples of activities that can be contained effectively in this manner. As the activity area gets larger, containment with an earthen berm can probably be provided less expensively than concrete curbing.

If a curb, berm or dike is used for runoff containment, and other containment sizing regulations (such as fire codes, Department of Ecology or Tacoma-Pierce County Health Department restrictions) do not apply, it should function so that all stormwater runoff from rain events up to the 6 month storm is contained in the immediate activity area until it infiltrates into the ground or is properly disposed of later. This approach is applicable for activities that involve liquid material storage, and that may consequently incur spills. It is also applicable to stockpile areas where runoff is typically polluted with suspended solids. If a stormwater treatment system is presently on-site, a valve should be installed in the containment dike so that excess stormwater can be drained out of the activity area and directed to the treatment system. This valve should always be kept closed unless excess stormwater is being discharged, so that any spills that occur within the activity area can be effectively contained.

Difficulties in maintenance may arise with disposal of the captured water on sites without stormwater treatment capability. The collected rainwater may need to be treated before discharge. If the activity is located on impermeable ground, then potentially contaminated water will accumulate within the containment area. If contaminated, this accumulated water cannot simply be drained from the area; it must be collected and disposed of at a licensed disposal facility. During the wet season, this course of action can lead to frequent draining that may prove costly. In addition, some type of monitoring would be needed to determine if ponded water is contaminated. Depending on the monitoring requirements, this can also be very costly.

For storage of small items, the simplest containment device is a tub or wading pool. A plastic child's wading pool may be sufficient for some activities that do not require a lot of space, such as storing painting materials, and temporary storage of wastes in drums. Make sure the material you are using does not react with the plastic. An example of this is shown in Figure 5.5.

For larger areas, a containment curb, dike, or berm may be necessary. If an earthen berm is used, it must be seeded with grass or other vegetation so that it does not erode. Sketches of a containment dike and a containment curb are shown in Figure 5.5.

The volume of the containment area should be equal to 110% of the volume of the largest tank.

It should be noted that neglect and poor maintenance can render the containment useless. Other BMPs should be considered before containment is. Commercial products are available that are a combination containment box/elevated pedestal. These effective devices prevent stormwater run-on by elevating containers off the ground, and allow for collection of spills and drips inside the pedestal box. Similar arrangements can be constructed by hand as well.

BMPs S.4, S.5 and S.6 in this chapter provide information on covering activities and sump installation.

## **BMP S.8      IMPLEMENT INTEGRATED PEST MANAGEMENT MEASURES**

Use of herbicides, fungicides, and rodenticides should always be done with extreme caution, not only because of the potential harm to humans and pets, but also because of the potential harm to fish, wildlife, and our water resources. In light of the toxic nature of these compounds, special attention should be given to pesticide usage in all applications. The discussion below applies more to large-scale pesticide users, but should be considered for backyard applications as well.

Commercial, agricultural, municipal, and other large scale pesticide users, such as golf courses and parks, should adhere to the principles of integrated pest management (IPM), a decision-making process for pest management that strives for intelligent, environmentally sound control of pests. It is a systems approach to pest management that combines agronomic, biological, chemical and genetic information for educated decisions on the type of control to use, the timing and extent of chemical application, and whether non-chemical means can attain an acceptable level of pest control.

IPM is a preventive measure aimed at knowing the exact pests being targeted for control, the locations and times when pests will pose problems, the level of pest-induced damage that can be tolerated without taking action, the most vulnerable life stage, and control actions that are least damaging to the environment. The major components of IPM are as follows:

- Monitoring and inventory of pest populations
- Determination of pest-induced injury and action levels
- Identification of priority pest problems
- Selection and timing of least toxic management tools
- Site-specific treatment with minimized chemical use
- Evaluation and adjustment of pesticide applications

Monitoring of pest populations is a key to successful IPM implementation. Pest problems are universally easier to control if the problem can be discovered early. With IPM, pesticides are used only as a last resort. Maximization of natural controls, including biological controls and removal of pests by hand, is always the first choice.

More information on IPM is available from the Washington State Department of Agriculture and from the Washington State University Extension Service, or in Appendix IV-B of this volume.



## **BMP S.9      CLEANING CATCH BASINS**

Cleaning catch basins regularly is one of the most important stormwater source control measures that a business can take.

Catch basins are typically located under low spots in parking lots, along curbs and road edges, and where storm drain pipes combine flows. Catch basins on the surface collect runoff for storm drains that are typically located directly underneath them. Most catch basins have some storage in the bottom that never drains to an outflow pipe. This permanent storage area is intended to trap sediments, debris, and other particles that can settle out of stormwater, thus preventing clogging of downstream pipes and washing of these solids into receiving waters.

For additional information on the maintenance of catch basins, refer to Volume V, Runoff Treatment BMPs, Section 4.6, number 5.

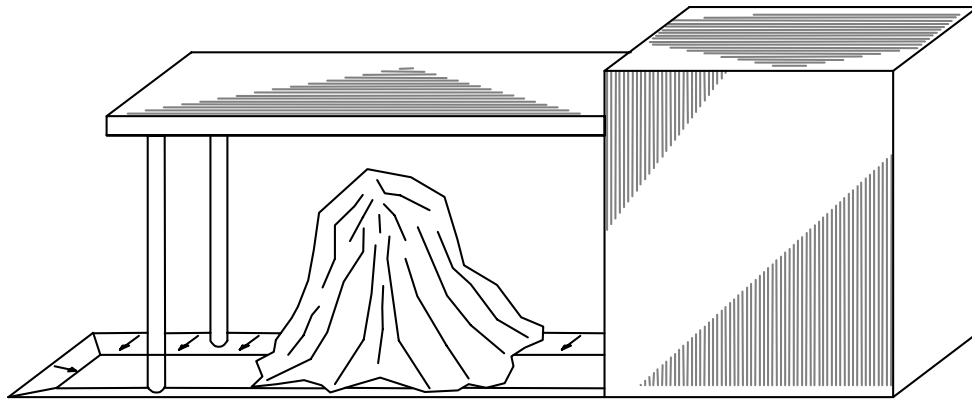
Several companies offer catch basin cleaning services. Pertinent equipment dealers and cleaning services can be found in the telephone Yellow Pages under headings like "Sewer Cleaning Equipment and Supplies" and "Sewer Contractors". All of the solids and stagnant water collected from catch basin sumps must be disposed of properly. None of the sump contents can be flushed into the catch basin outflow pipe. Depending on the nature of the pollutants in the sump, and the associated types of activities taking place on the site, the sump contents may need to be disposed of as hazardous waste. Contractors who perform catch basin cleanout services will be required to follow specified disposal requirements.

It should be apparent that use of other BMPs, such as frequent sweeping of activity areas, covering activity areas, reducing activity occurrence and containing runoff from activity areas will help reduce catch basin cleaning frequency, thus saving time and money. All businesses and agencies should set up maintenance schedules for all of their BMPs so that coordinated BMP maintenance efforts result in reduced catch basin cleaning frequencies.

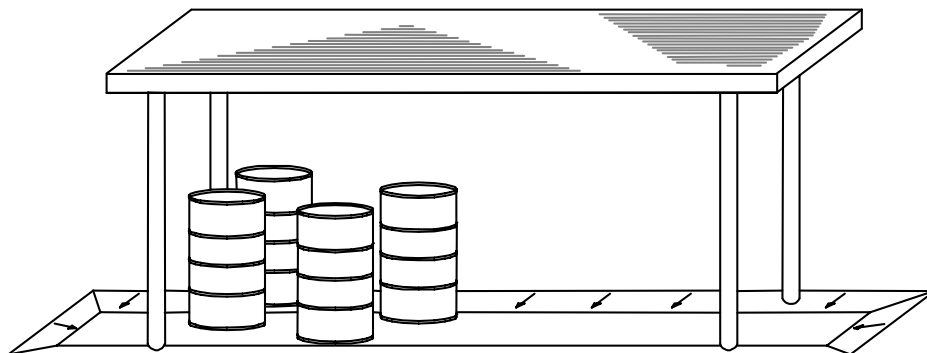
### **5.3 Treatment BMPs**

The previous section gave you source control BMPs -- in other words, how to prevent stormwater from becoming contaminated in the first place. Information on stormwater treatment BMPs can be found in Volume 1, Section 1.4 and Volume 5, particularly Chapter 2.

**FIGURE 5.1**  
**Roofs & Awnings**

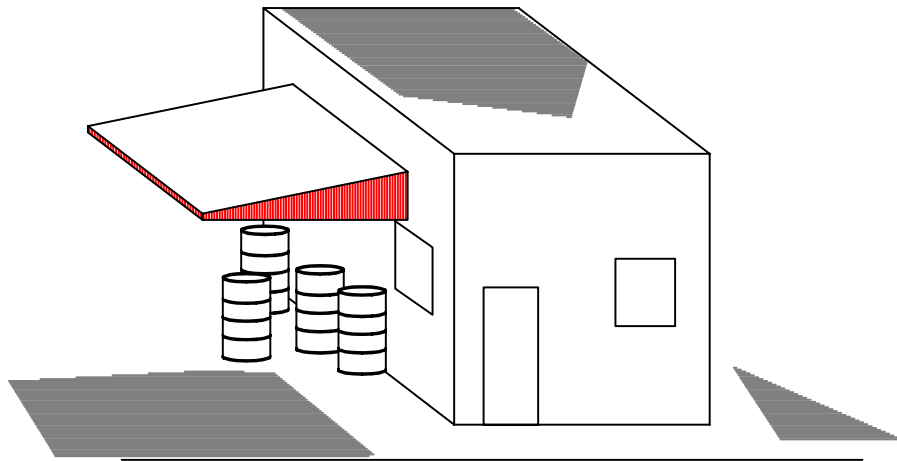


LEAN-TO STRUCTURE  
N.T.S.

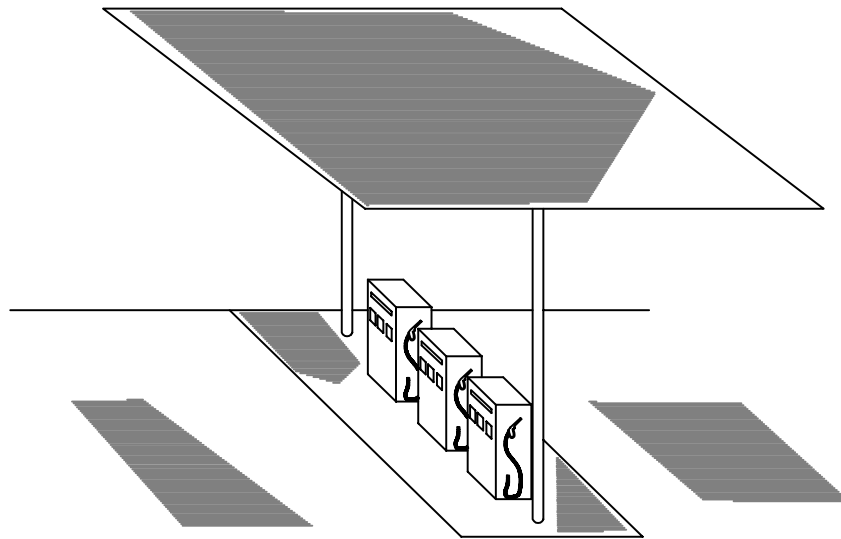


STAND-ALONE CANOPY  
N.T.S.

**FIGURE 5.2**  
**Roofs & Awnings**

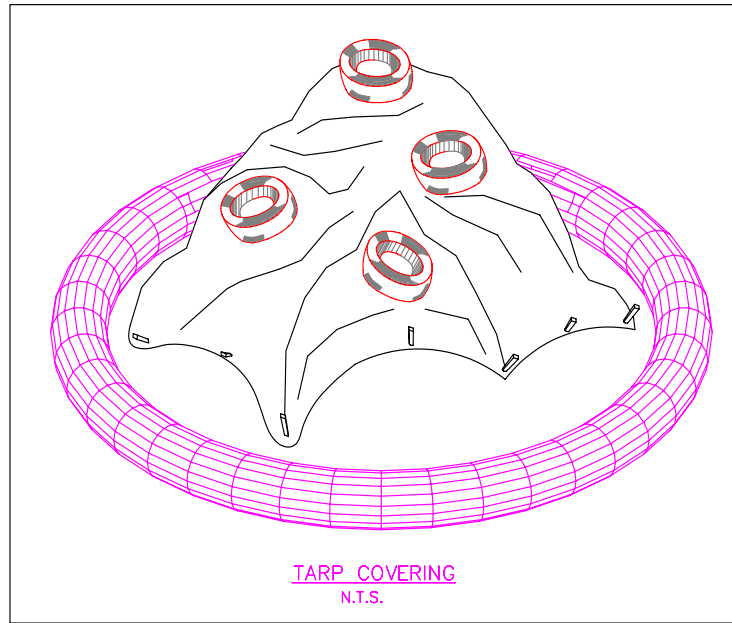


OVERHANGING AWNING  
N.T.S.

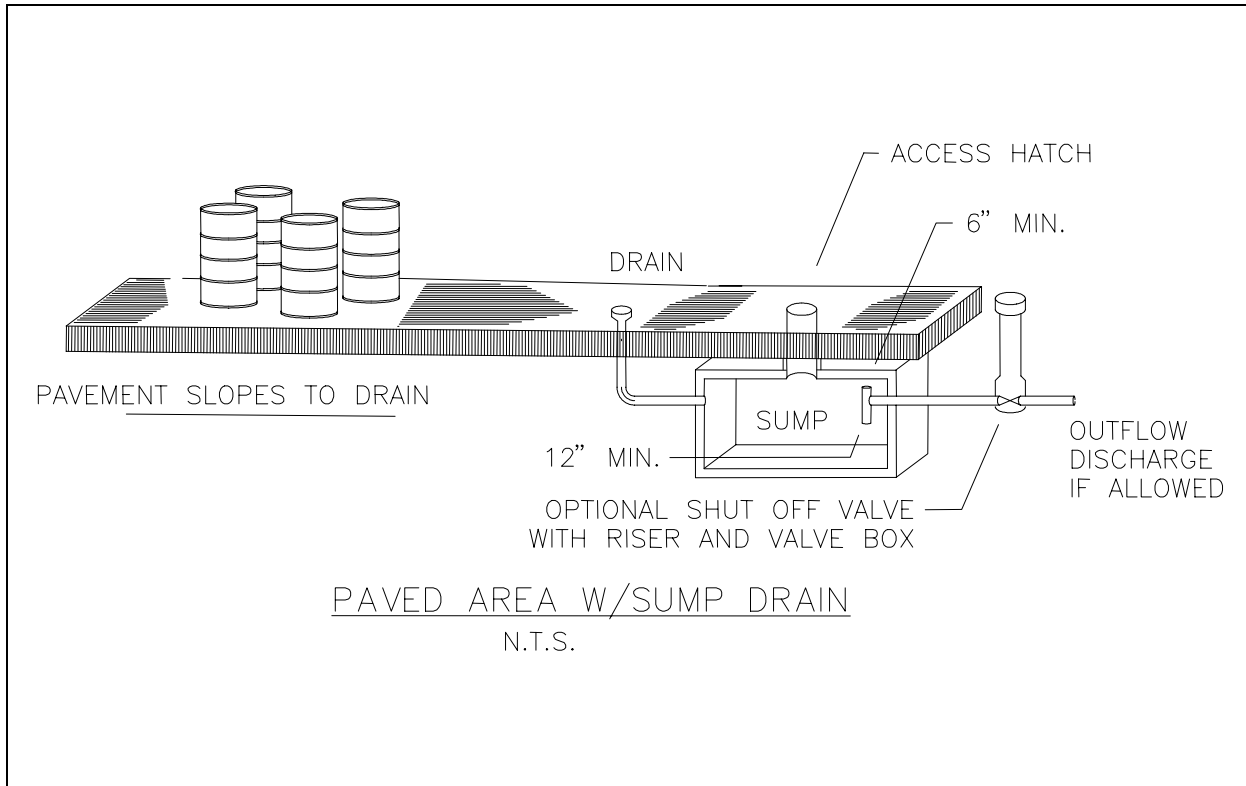


ISLAND-TYPE OVERHANGING ROOF  
N.T.S.

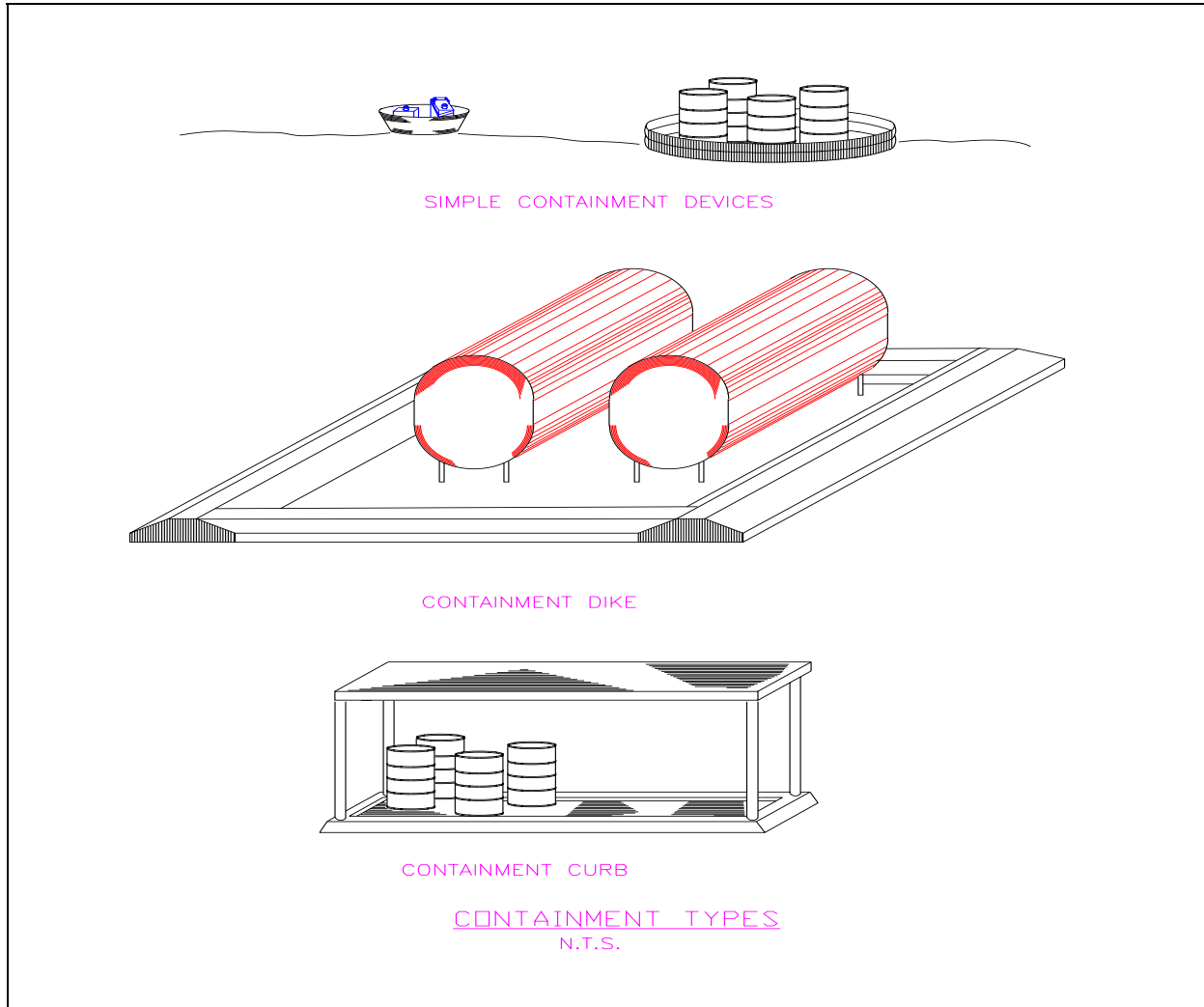
**FIGURE 5.3  
Tarp Covering**



**FIGURE 5.4  
Paved Area with Sump Drain**



**FIGURE 5.5**  
**Containment Types**



# Chapter 6 – Regulations and Requirements

---

The information in this chapter is provided to help you comply with other Tacoma and Washington State regulations, which may apply to your project, industry or business in terms of protecting water quality. Some of the State regulations are summarized for your convenience. Because of the continuing modification of statutes, regulations, and City ordinances, a listing of relevant regulations is provided but should be verified. It is your responsibility to obtain the current version of any ordinances, statutes, or regulations that apply to your project. Copies of City ordinances are available at the City Clerk's office at the Municipal Building located at 747 Market Street, 253-591-5171.

## 6.1 City of Tacoma Codes and Ordinances

- 2.02.090..... Off-Site Improvements
- 2.02.330 ..... Grading and Excavation Code
- 2.12..... Flood Hazard and Coastal High Hazard Areas
- 2.13..... Waterfront Structures and Marinas
- 2.17..... Penalties for Non-Compliance with Ordinances
- 5.04..... Infectious Waste Management
- 5.20..... Garbage, Rubbish and Pollution
- 5.47..... Underground Storage Tank Removal
- 5.50..... Swimming Pools
- 8.30..... Nuisances
- 9.16..... Streets and Sidewalks - Keeping Clean
- 10.14.080..... Drainage of Surface Water
- 12.08..... Sewage Disposal - Regulations and Rates (Includes stormwater requirements)
- 12.09..... Solid Waste, Recycling, and Hazardous Waste
- 13.10..... Shoreline Management
- 13.09..... South Tacoma Groundwater Protection District
- 13.11..... Critical Areas Preservation
- 13.12..... Environmental Code

## 6.2 State, Federal, and Other Regulations and Requirements

- R.1 Washington State Department of Ecology (Ecology) requirements for the discharge of process wastewaters directly to surface waters
- R.2 Ecology requirements for generators of dangerous (hazardous) wastes
- R.3 Ecology stormwater NPDES permit requirements
- R.4 Ecology requirements for underground and above ground storage tanks.
- R.5 EPA and Ecology requirements for spill-control and prevention plans

- R.6 Washington State Department of Agriculture (WSDA) pesticide regulations
- R.7 Puget Sound Air Pollution Control Agency (PSAPCA) air quality regulations
- R.8 Requirements of Native American Tribes

**R.1 WASHINGTON STATE DEPARTMENT OF ECOLOGY  
REQUIREMENTS FOR THE DISCHARGE OF PROCESS  
WASTEWATERS DIRECTLY TO SURFACE WATERS**

If a public sanitary sewer is not available, process wastewater may be discharged, after suitable treatment, to a surface waterbody like a lake or stream, or to a drainage field. If the discharge is to a surface water body, Ecology must be contacted to obtain approval of the type and design of the treatment system, as well as the design and location of the outfall and the need for an NPDES Permit. If a septic tank and drainfield are used for treatment, requirements of the Tacoma-Pierce County Health Department will also apply; contact the On-Site Sewage Program directly at 253-798-6470 for more information.

Ecology's requirements can be found at WAC Chapter 173.240. Some of the specific requirements include:

1. An engineering report must be prepared describing the proposed project. The general contents of the engineering report are specified by Ecology (WAC Chapter 173-240). The report is reviewed and approved by Ecology.
2. The treatment system must be designed in accordance with *Criteria for Sewage Works Design*, October 1985, by Ecology.
3. The outfall must be designed in accordance with specific dilution zone dimensions (WAC Chapter 173-201A-100).
4. The quality of the discharge into the receiving water must be treated and diluted (according to the dilution criteria noted above) so as to not result in a violation of water quality standards (WAC Chapter 173-201A).
5. The treatment plant must be properly maintained and operated by a certified operator (WAC Chapter 173-230).

**R.2 WASHINGTON STATE DEPARTMENT OF ECOLOGY  
REQUIREMENTS FOR DANGEROUS WASTE  
GENERATORS**



The state dangerous waste regulations (WAC Chapter 173-303) cover accumulation, storage, transportation, treatment and disposal. Of interest to this manual is the temporary accumulation of waste until taken from the site to a permitted disposal site. Only portions of those regulations that apply to temporary storage are summarized here.

### **Permitted Generators**

Businesses that generate 220 pounds or more of waste, either per batch or in the aggregate, over one month must comply with the storage specifications outlined below:

*If placed in containers:*

1. If the container is not in good condition (for example, severe rusting or apparent structural defects) or if it begins to leak, the owner must replace the container.
2. The container must be labeled as to its contents.
3. The container must be lined with a material that does not react with the waste.
4. The container must be kept closed except when adding or removing waste.
5. The container must not be opened, handled, or stored in a manner which may cause a rupture or leak.
6. At least weekly examine the containers for leakage.
7. Containers storing reactive or ignitable waste must meet requirements of the Uniform Fire Code.
8. Incompatible wastes must be stored separately.
9. Ecology may require secondary containment of the storage area. Specifically, the storage area must:
  - a. Be capable of collecting and holding spills and leaks.
  - b. If uncovered, be capable of handling a 25-year storm.
  - c. Have a base that is free of cracks or gaps and is sufficiently impervious to leaks, spills, and rainfall.
  - d. Be sloped or designed so that liquids can drain to a point for removal.
  - e. Have positive drainage control (e.g., a valve) to ensure containment until any liquid is removed, which must occur in a timely manner.

- f. Have a holding capacity equal to 10 percent of the volume of all containers or the volume of the largest container, whichever is greater.
- g. Not allow run-on of rainfall from areas adjacent to the storage area.

If the waste does not contain free liquids, the above requirements need not be met, provided that the area is sloped or the containers are elevated.

*If placed in tanks:*

1. The tank must be lined with a material that does not react with the waste.
2. The tank, tank area, and its ancillary equipment must be inspected according to a written schedule.
3. If retired, the tank is to be cleaned of all contents, and those contents properly disposed of.
4. Tanks storing reactive or ignitable waste must meet the Uniform Fire Code.
5. Incompatible wastes must be stored separately.

The generators must have a designated employee on site or on call with the responsibility for coordinating all emergency response measures. Spills are to be contained and cleaned up as soon as practicable.

### **Small-Quantity Waste Generators**

These are businesses that generate less than 220 pounds of dangerous waste per month or per batch (or 2.2 pounds of extremely hazardous waste). Small-quantity generators still fall under Ecology regulations to the extent that the materials must be properly stored on site until shipment. The wastes must be moved from the property whenever the accumulated quantity equals or exceeds 220 pounds or whenever the material has resided on site for 180 days. The waste must be disposed of at an approved facility. If the business is in compliance with these requirements, they are also considered solid waste generators, and are regulated by the Tacoma-Pierce County Health Department. For technical assistance and site visits, contact the Tacoma-Pierce County Health Department at 253-798-6047 or the City of Tacoma at 253-591-5588. Regulations governing small-quantity generators are currently being reviewed to possibly raise the accumulation limit. Call the Hazardous Waste Line at 800-287-6429 for the most up-to-date information.

## **Dangerous Waste Pollution Prevention Plans**

A recent state law established the requirement that generators of dangerous wastes in excess of 220 lbs/month (2,640 lbs/year) prepare a waste reduction plan, called a pollution prevention plan, not to be confused with the stormwater pollution prevention plan (see R.4). The required content of the plan is set forth in *Pollution Prevention Planning - Guidance Manual*, January 1992, Publication #91-2, for WAC Chapter 173-307.

Many of the actions described in these plans may benefit stormwater quality and thus should be integrated into any decisions about the selection of the BMPs described in Chapters 4 and 5 of this manual.

See WAC Chapters 173-303 and 307 for further details, as well as the above-named publication.

### **R.3 WASHINGTON STATE DEPARTMENT OF ECOLOGY STORMWATER NPDES PERMIT REQUIREMENTS**

The Federal National Pollutant Discharge Elimination System (NPDES) program requires industries or industrial-type activities to obtain permits for stormwater discharge.

Coverage under Ecology's general permit for Stormwater Discharges Associated with Industrial Activities for each regulated facility. A business must obtain permit coverage if its primary activity falls under one of the categories listed in the permit or its fact sheet. The permit and fact sheet may be viewed on Ecology's website at [www.ecy.wa.gov/programs/wq/permits/index.html](http://www.ecy.wa.gov/programs/wq/permits/index.html).

The program requires the preparation of a stormwater pollution prevention plan (SWPPP or SWP3). A NPDES permit is required for certain categories of industries and municipalities for discharge to surface water, or a storm drain that discharges to surface water or to surface water and groundwater.

### **R.4 ECOLOGY REQUIREMENTS FOR UNDERGROUND AND ABOVE GROUND STORAGE TANKS**

#### **Underground Storage Tanks**

Underground storage tanks (UST) that contain fuel and other petroleum products are regulated by the Department of Ecology under **WAC Chapter 173-360 Underground Storage Tank Regulations**. This law applies to USTs that have a capacity of greater than 110 gallons. USTs which store federally listed or otherwise regulated hazardous waste, heating fuel on the premises where used, farm or residential USTs less than 1,100

gallons in size and other types are exempt from these regulations (WAC Chapter 173-360-110).

The state UST regulations require permits for USTs in use after July 1991. Specific performance criteria such as design, integrity testing, inventory control, UST performance monitoring, spill control and reporting for new USTs are outlined in this regulation. USTs in existence prior to adoption of this regulation in 1990 must meet the upgrade criteria or new UST requirements by 1998 or complete closure of the system.

USTs that have been closed or taken out of service after December 1988 must complete closure (removal or in-place closure) in accordance with WAC Chapter 173-360. Requirements for UST closure with Ecology include submittal of a 30-day notice of closure, site assessment, and completion of any applicable cleanup actions. A report of the closure actions must be submitted to Ecology.

### **Above Ground Storage Tanks**

Above ground storage tanks (AST) which store dangerous wastes are regulated under **WAC Chapter 173-303 Dangerous Waste Regulations**, which is administered by Ecology. Underground storage tanks which store dangerous wastes must also meet the criteria for tanks in this regulation. Businesses which store, handle or generate dangerous wastes are regulated under this regulation based on the volume of dangerous waste generated. The Dangerous Waste Regulations have specific requirements for AST integrity, corrosion protection, secondary containment, leak detection, and use and management criteria, in addition to general requirements for businesses that have dangerous wastes.

For ASTs which contain other types of materials such as petroleum products or raw materials, the Department of Ecology guidance document ***Guidelines to Prevent, Control, and Contain Spills from the Bulk Storage of Petroleum Products*** is available for technical guidance.

Inquiries about business-specific requirements and permitting for USTs and ASTs should be directed to the Department of Ecology, Southwest Regional Office at 360-407-6300.

## **R.5 U.S. EPA AND WASHINGTON STATE DEPARTMENT OF ECOLOGY EMERGENCY SPILL CLEANUP REQUIREMENTS**

### **USEPA - Spill Prevention Control and Cleanup (SPCC) Plans (40 CFR 112)**

This federal regulation requires that owners or operators of facilities engaged in drilling, producing, gathering, storing, processing, refining, transferring, or consuming oil and oil products are required to have a spill prevention and control plan (SPCC), provided that the facility is not transportation related; and, that the aboveground storage of a single container is in excess of 660 gallons, or an aggregate capacity greater than 1,320 gallons, or a total below ground capacity in excess of 42,000 gallons.

*The plan must:*

1. Be well thought out in accordance with good engineering.
2. Achieve three objectives - prevent spills, contain spills that occur, cleanup spills.
3. Identify name, location, owner, and type of facility.
4. Have date of initial operation and oil spill history.
5. Designate the person responsible.
6. Be approved and certified by the person in authority.
7. Contain a facility analysis.
8. Tanks must have secondary containment and leak detection.

### **Department of Ecology Dangerous Wastes (WAC 173-303-350)**

The regulations state that generators must have a contingency plan that must include:

1. Actions taken in the event of a spill.
2. Descriptions of arrangements with local agencies.
3. Identification of the owner's emergency coordinator.
4. List of emergency equipment.
5. Evaluation plan for business personnel.

See Federal Regulation 40 CFR 112 and WAC 173-303-350 for further information.

## **R.6 WASHINGTON STATE DEPARTMENT OF AGRICULTURE PESTICIDE REGULATIONS**

Washington State pesticide laws are administered by the State's Department of Agriculture, under the Washington Pesticide Control Act (RCW Chapter 15.58), Washington Pesticide Application Action (RCW Chapter 17.21), and regulations in WAC Chapter 16.228. In Tacoma, all pest control operators and fumigators are required to obtain certification from the Tacoma-Pierce County Health Department. Contact the Health Department's Compliance Program at 798-6440 for more information. The requirements relevant to water quality protection are:

1. Persons who apply pesticides are required to be licensed **except:**
  - a. People who use general-use pesticides on their own or their employer's property.
  - b. Grounds maintenance people using only general use pesticides on an occasional basis not amounting to a regular occupation.
  - c. Governmental employees who apply general use pesticides without utilizing any kind of motorized or pressurized apparatus.
  - d. Employees of a commercial applicator or a government agency who are under direct on-site supervision by a licensed applicator.
2. Licensed applicators must undergo 40 hours of continuing education to keep the license.
3. No person shall pollute streams, lakes, and other water supplies in pesticide loading, mixing and application.
4. No person shall transport, handle, store, load, apply, or dispose of any pesticide, pesticide container, or apparatus in such a manner as to pollute water supplies or waterways, or cause damage or injury to land, including human beings, desirable plants, and animals.

See WAC Chapter 16.228 for further details.

## **R.7 PUGET SOUND CLEAN AIR AGENCY AIR QUALITY REGULATIONS**

The Puget Sound region is under the jurisdiction of regional air quality authorities who in turn must function under Washington State and federal air quality regulations. The Puget Sound Clear Air Agency (PSCAA) is the regulatory agency for air quality in Tacoma.

The air authority has policies on fugitive dust and outside painting. PSCAA requires that reasonable precautions be taken to prevent fugitive particulate material from becoming airborne when handling, loading, transporting or storing particulate material. PSCAA defines what are reasonable precautions such as: the paving of parking lots and storage areas, housekeeping measures to minimize the accumulation of mud and dust, and to prevent its tracking onto public roads, and stabilization of storage piles with water spray, chemical stabilizers, tarps, or enclosure.

PSCAA requires that abrasive blasting and spray painting operations be performed inside a booth designed to capture the blast grit or overspray. Outdoor blasting or painting of structures or items too large to be handled indoors are to be enclosed with tarps. Containers of solvents and coatings are to be kept closed. The *Compliance Guidelines* specify how spraying equipment is to be cleaned. It also requires an operation and maintenance plan for spray operations.

See *Compliance Guidance for Spray Coating Operations*, PSCAA.

PSCAA regulations may be viewed on the agency's website at [www.pscleanair.org](http://www.pscleanair.org).

## **R.8 REQUIREMENTS OF NATIVE AMERICAN TRIBES**

Tribal staff review federal, state, and local permits for projects on tribal lands or projects on non-tribal lands that may affect treaty-reserved resources or areas. The Puyallup Indian Tribe has lands and continuing treaty interests in natural resources. Check with their Natural Resource or Environmental Divisions for more information on the treaty rights and the permit review role of the tribe.

## Chapter 7 – Quick Reference Phone Numbers

---

Environmental Protection Agency (EPA) - Region X	800-424-4372
IMEX (Industrial Materials Exchange)	206-296-4899
City of Tacoma	
Stormwater Source Control Unit	253-591-5588
Sanitary Source Control Unit	253-591-5588
Pretreatment Program	253-591-5588
Building and Land Use Services (Permits)	253-591-5030
Fire Prevention Bureau	253-591-5740
Solid Waste Management Utility	253-591-5543
Household Hazardous Waste	253-591-5418
Recycling Services	253-565-5955
Tacoma-Pierce County Health Department	
On-Site Sewage and Underground Storage Tanks	253-798-6470
Hazardous Waste Section	253-798-6047
Solid Waste	253-798-6047
Hazardous Waste Line	800-287-6429
Pest Control Operators and Fumigators	253-798-6470
University of Washington Center for Urban Water Resources	206-543-6272
Washington State Department of Agriculture	360-902-2010 877-301-4555
Washington State Department of Ecology	360-407-6000
Southwest Regional Office	360-407-6300
Dangerous/Hazardous Waste	360-407-6300
NPDES Stormwater or Wastewater permits	360-407-6400
Spill Reporting	800-424-8802
Recycling	800-732-9253
Groundwater Quality and Protection	360-407-6400
Underground and Above Ground Storage Tanks	360-407-7170
Washington State University/Pierce County Cooperative Extension	253-798-7180
Puyallup Tribe	253-597-6200
Puget Sound Clean Air Agency	800-552-3565



## Appendix IV-A

### Recycling/Disposal of Vehicle Fluids/Other Wastes\*

	RECOMMENDED MANAGEMENT
<b>Antifreeze</b>	Store separately for resale. Separate ethylene glycol from propylene glycol for off-site recycling. If not recyclable, send to Treatment, Storage, and Disposal Facility (TSDF) for disposal.
<b>Batteries</b>	INTACT: Accumulate under cover prior to sale, deliver to recycler or, return to manufacturer. BROKEN: Accumulate acid from broken batteries in resistant containers with secondary containment. Send to TSDF for disposal.
<b>Brake fluid</b>	Accumulate in separate, marked, closed container. Do not mix with waste oil. Recycle.
<b>Fuel</b>	Store gasoline, and diesel separately for use or resale. Mixtures of diesel, gasoline, oil, and other fluids may not be recyclable and may require expensive disposal.
<b>Fuel filters</b>	Drain fluids for use as product. With approval of local landfill operator, dispose to dumpster, if needed.
<b>Oil filters</b>	Puncture the filter dome and drain it for 24 hours. Put oil drained from filters into your "USED OIL ONLY" container. Keep drained filters in a separate container marked "USED OIL FILTERS ONLY." Locate a scrap metal dealer who will pick up and recycle your filters. With approval of local landfill operator, dispose of drained filters to dumpster.
<b>Paint</b>	Accumulate oil-based and water-based paints separately for use or resale. If not recyclable, send accumulations to TSDF for disposal.
<b>Power steering fluid</b>	Same as for used oils
<b>Shop towels/oily rags</b>	Use cloth towels that can be laundered and reused. Accumulate used shop towels in a closed container. Sign up with an industrial laundry service that can recycle your towels.
<b>Solvents</b>	Consider using less hazardous solvents or switching to a spray cabinet that doesn't use solvent. Accumulate solvents separately. Consider purchasing your own solvent still and recycling solvent on site. Do not mix with used oil. Do not evaporate as a means of disposal.
<b>Transmission oil, differential and rear end fluids</b>	Accumulate in your "USED OIL ONLY" container. Arrange for pickup for off-site recycling.
<b>Used oils; including, crankcase oil, transmission oil, power steering fluid and differential/rear end oil</b>	Keep used oil in a separate container marked "USED OIL ONLY." Do not mix with brake fluid, or used antifreeze. Do not mix with any other waste if you plan to burn it in your shop for heating. Arrange for pickup for off-site recycling.
<b>Windshield washer fluid</b>	Accumulate separately for use or resale. Discharge to on-site sewage disposal, or, if acceptable by the local sewer authority, discharge to sanitary sewer.

\* This information was obtained from Ecology's Hazardous Waste Program.

For a copy of "Hazardous Waste Services Directory," Publication #91-12s, Revised December 1994, listing facilities which recycle/dispose of wastes, solvents, paints, photographic wastes, refrigerants, oils, oil filters, and silver; provide spill assistance and oil/water separator cleanout service, and drum disposal/recycling; TSD facilities; and waste brokers; call Ecology's Hazardous Waste and Toxic Reduction Program at (360) 407-6721.

# Appendix IV-B

## Example of an Integrated Pest Management Program

---

Integrated Pest Management (IPM) is a natural, long-term, ecologically based systems approach to controlling pest populations. This system uses techniques either to reduce pest populations or maintain them at levels below those causing economic injury, or to so manipulate the populations that they are prevented from causing injury. The goals of IPM are to encourage optimal selective pesticide use (away from prophylactic, broad spectrum use), and to maximize natural controls to minimize the environmental side effects.

A step-by-step comprehensive Integrated Pest Management (IPM) Program is provided below as a guide:

### Introduction

This section provides a sound cultural approach to managing lawns and landscapes and minimizing runoff. Many homeowners or property managers will be able to implement most or all of this approach, others will wish to hire these services out. For the do-it yourselfer, an array of resources are available to assist in the effort. Landscaping businesses, agricultural extensions, local agencies, master gardener programs, local nurseries and even the library can all provide assistance. Landscaping professionals (businesses) are particularly encouraged to practice IPM.

### Definition

“Integrated pest management, or IPM, is an approach to pest control that uses regular monitoring to determine if and when treatments are needed, and employs physical, mechanical, cultural, and biological tactics to keep pest numbers low enough to prevent intolerable damage or annoyance. Least-toxic chemical controls are used as a last resort.”

True IPM is a powerful approach that anticipates and prevents most problems through proper cultural practices and careful observation. Knowledge of the life cycles of the host plants and both beneficial and pest organisms is also important. The IPM section of this study guide is adapted from Least Toxic Pest Management for Lawns by Sheila Daar. Following the IPM process gives you the information you need to minimize damage by weeds, diseases and pests and to treat those problems with the least toxic approaches.

### The Integrated Pest Management Process

#### **Step One: Correctly identify problem pests and understand their life cycle.**

Learn more about the pest. Observe it and pay attention to any damage that may be occurring. Learn about the life cycle. Many pests are only a problem during certain seasons, or can only be treated effectively in certain phases of the life cycle.

#### **Step Two: Establish tolerance thresholds for pests.**

Every landscape has a population of some pest insects, weeds, and diseases. This is good because it supports a population of beneficial species that keep pest numbers in check.

Beneficial organisms may compete with, eat, or parasitize disease or pest organisms. Decide on the level of infestation that must be exceeded before treatment needs to be considered. Pest populations under this threshold should be monitored but don't need treatment. For instance, European crane flies usually don't do serious damage to a lawn unless there are between 25-40 larvae per square foot feeding on the turf in February (in normal weather years). Also, most people consider a lawn healthy and well maintained even with up to 20% weed cover, so treatment, other than continuing good maintenance practices, is generally unnecessary.

### **Step Three: Monitor to detect and prevent pest problems.**

Regular monitoring is a key practice to anticipate and prevent major pest outbreaks. It begins with a visual evaluation of the lawn or landscape's condition. Take a few minutes before mowing to walk around and look for problems. Keep a notebook, record when and where a problem occurs, then monitor for it at about the same time in future years. Specific monitoring techniques can be used in the appropriate season for some potential problem pests, such as European crane fly.

### **Step Four: Modify the maintenance program to promote healthy plants and discourage pests.**

A healthy landscape is resistant to most pest problems. Lawn aeration and overseeding along with proper mowing height, fertilization, and irrigation will help the grass out-compete weeds. Correcting drainage problems and letting soil dry out between waterings in the summer may reduce the number of crane-fly larvae that survive.

### **Step Five: If pests exceed the tolerance thresholds**

Use cultural, physical, mechanical or biological controls first. If those prove insufficient, use the chemical controls described below that have the least non-target impact. When a pest outbreak strikes (or monitoring shows one is imminent), implement IPM then consider control options that are the least toxic, or have the least non-target impact. Here are two examples of an IPM approach:

- 1. Red thread disease** is most likely under low nitrogen fertility conditions and most severe during slow growth conditions. Mow and bag the clippings to remove diseased blades. Fertilize lightly to help the grass recover, then begin grasscycling and change to fall fertilization with a slow-release or natural-organic fertilizer to provide an even supply of nutrients. Chemical fungicides are not recommended because red thread cannot kill the lawn.
- 2. Crane fly damage** is most prevalent on lawns that stay wet in the winter and are irrigated in the summer. Correct the winter drainage and/or allow the soil to dry between irrigation cycles; larvae are susceptible to drying out so these changes can reduce their numbers. It may also be possible to reduce crane fly larvae numbers by using a power de-thatcher on a cool, cloudy day when feeding is occurring close to the surface. Studies are being conducted using beneficial nematodes that parasitize the crane fly larvae; this type of treatment may eventually be a reasonable alternative.

Only after trying suitable non-chemical control methods, or determining that the pest outbreak is causing too much serious damage, should chemical controls be considered. Study to determine

what products are available and choose a product that is the least toxic and has the least non-target impact. Refer to the Operational BMPs for the use of Pesticides below for guidelines on choosing, storing and using lawn and garden chemicals.

**Step Six: Evaluate and record the effectiveness of the control, and modify maintenance practices to support lawn or landscape recovery and prevent recurrence.**

Keep records! Note when, where, and what symptoms occurred, or when monitoring revealed a potential pest problem. Note what controls were applied and when, and the effectiveness of the control. Monitor next year for the same problems. Review your landscape maintenance and cultural practices to see if they can be modified to prevent or reduce the problem.

A comprehensive IPM Program should also include the proper use of pesticides as a last resort, and vegetation/fertilizer management to eliminate or minimize the contamination of stormwater.

# Appendix IV-C

## Recommendations for Management of Street Wastes

---

### Introduction

This appendix is a summary, taken from the June 1999 draft Ecology publication titled Recommendations for Management of Street Waste (Publication WQ 99-09). The guidance document addresses waste generated from stormwater maintenance activities such as street sweeping and the cleaning of catch basins, and to a limited extent, other stormwater conveyance and treatment facilities. Limited information is available on the characteristics of wastes from detention/retention ponds, bioswales, and similar stormwater treatment facilities. The recommendations provided here may be generally applicable to these facilities, with extra diligence given to waste characterization.

These recommendations do not constitute rules or regulations, but are suggestions for street waste handling, reuse, and disposal using current regulations and the present state of knowledge of street waste constituents. The recommendations are intended to address the liquid and solid wastes collected during routine maintenance of stormwater catch basins, detention/retention ponds and ditches and similar storm water treatment and conveyance structures, and street and parking lot sweeping. In addition to these recommendations, end users and other authorities may have their own requirements for street waste reuse and handling.

**"Street Wastes"** include liquid and solid wastes collected during maintenance of stormwater catch basins, detention/retention ponds and ditches and similar storm water treatment and conveyance structures, and solid wastes collected during street and parking lot sweeping.

**"Street Wastes," as defined here, does not include** solids and liquids from street washing using detergents, cleaning of electrical vaults, vehicle wash sediment traps, restaurant grease traps, industrial process waste, sanitary sewage, mixed process, or combined sewage/stormwater wastes. Wastes from oil/water separators at sites that load fuel are not included as street waste. Street waste also does not include flood debris, land slide debris, and chip seal gravel.

**Street waste does not ordinarily classify as dangerous waste.** The owner of the storm water facility and/or collector of street waste is considered the waste generator and is responsible for determining whether or not the waste designates as dangerous waste. Sampling to date has shown that material from routine maintenance of streets and stormwater facilities does not classify as dangerous waste (See Table D.6 below). However, it is possible that street waste from spill sites could classify as dangerous waste. Street waste from areas with exceptionally high average daily traffic counts may contain contaminants - such as heavy metals, total petroleum hydrocarbons (TPH), and carcinogenic polycyclic aromatic hydrocarbons (c-PAH) - at levels that limit reuse options.

### Street Waste Solids

**Street waste is solid waste.** While street waste from normal street and highway maintenance is not dangerous waste, it is solid waste, as defined under The Solid Waste Management Act (Chapter 70.95 RCW) and under Minimum Functional Standards for Solid Waste Handling (Chapter 173-304 WAC). Under the Solid Waste Management Act, local health departments have primary jurisdiction over solid waste management. Street waste solids may contain

contaminants at levels too high to allow unrestricted reuse. At the time this document is being prepared, the Minimum Functional Standards are being revised. Chapter 173-304 WAC will be replaced with Chapter 173-350 WAC. There are currently no specific references in the Minimum Functional Standards to facilities managing street waste solids. These facilities will typically fit under the section dealing with Piles Used for Storage and Treatment (Section 320 of the proposed revisions). There are no specific references for reuse and disposal options for street wastes in the Minimum Functional Standards, although the Minimum Functional Standards do not apply to clean soils. In the proposed rule, clean soils are defined as 'soils that do not contain contaminants at concentrations which could degrade the quality of air, waters of the state, soils, or sediments; or pose a threat to the health of humans or other living organisms' (WAC 173-350-100). Whether or not a soil is a clean soil depends primarily upon the level of contaminants and, to a lesser degree, on the background level of contaminants at a particular location and the exposure potential to humans or other living organisms. Therefore, both the soil and potential land application sites must be evaluated to determine if a soil is a clean soil. Local health departments should be contacted to determine if a street waste meets the definition of "clean soil" when it will be reused as a soil.

There is no simple regulatory mechanism available to classify street waste solids as "clean" for uncontrolled reuse or disposal. Local health districts have historically used the Model Toxics Control Act Cleanup Regulation (MTCA) Method A residential soil cleanup levels to approximate "clean" and to make decisions on land application proposals. These regulations were amended in February 2001. The MTCA regulation is not intended to be directly applied to setting contaminant concentration levels for land application proposals. However, they may provide human health and environmental threat information and a useful framework for such decisions, when used in conjunction with other health and environmental considerations. The local health department should be contacted to determine local requirements for making this determination.

Using the old MTCA regulations, many local health departments have set a criteria of 200 mg/Kg Total Petroleum Hydrocarbons (TPH) for diesel and heavy fuel oils as a threshold level for clean soil. Using the new MTCA terrestrial ecological evaluation procedures, allowable TPH levels for land application could range from 200 – 460, depending on site characteristics and intended land use. Street waste sampling has historically yielded TPH values higher than 200 mg/kg for hydrocarbons in the diesel and heavy oil range. These values typically reflect interference from natural organic material and, to a lesser extent, relatively immobile petroleum hydrocarbons. The mobile hydrocarbons that are of concern for ground water protection are generally not retained with street waste solids. Ecology's Manchester Lab has developed an analytical method to reduce the problem of natural organic material being included in the TPH analysis for diesel and heavier range hydrocarbons. This new method, called NWTPH-Dx, reduces the background interference associated with vegetative matter by as much as 85% to 95%. However, even with the new methodology, TPH test results for street waste may still be biased by the presence of natural vegetative material and may still exceed 200 mg/kg. . Where the laboratory results report no 'fingerprint' or chromatographic match to known petroleum hydrocarbons, the soils should not be considered to be petroleum contaminated soils.

Street waste solids frequently contain levels of carcinogenic PAHs (c-PAH) that make unrestricted use inappropriate. This is complicated further by analytical interference caused by organic matter that raises practical quantitation or reporting limits. To greatly reduce the level of interference, the use of US EPA Test Method 8270, incorporating the silica gel cleanup step, is recommended. The calculated c-PAH value can vary greatly depending upon how non-detect values are handled. The new MTCA Method A criterion for c-PAH is 0.1 mg/kg (the sum of all

seven c-PAH parameters multiplied by the appropriate toxicity equivalency factor)) for unrestricted land uses. The MTCA criteria for soil cleanup levels for industrial properties is 2.0 mg/kg. Following this guidance, most sites where street wastes could be reused as soil will be commercial or industrial sites, or sites where public exposure will be limited or prevented.

**Permitting of street waste treatment and storage facilities as solid waste handling facilities by the local health department is required.** Under the Solid Waste Management Act, local health departments have primary jurisdiction over solid waste management

Street waste handling facilities are subject to the requirements of the Minimal Functional Standards for Solid Waste Handling. The specific requirements will depend upon the manner in which the waste is managed. Most facilities will probably be permitted under the section dealing with Piles Used for Storage and Treatment (Section 320 of the proposed revisions)

For most facilities, permit requirements include a plan of operation, sampling, record keeping and reporting, inspections, and compliance with other state and local requirements. The plan of operation should include a procedure for characterization of the waste and appropriate reuse and disposal options, consistent with the recommendations in this document and applicable federal, state and local requirements.

**A street waste site evaluation (see sample at end of this appendix) is suggested for all street waste as a method to identify spill sites or locations that are more polluted than normal.** The disposal and reuse options listed below are based on characteristics of routine street waste and are not appropriate for more polluted wastes. The collector of street waste should evaluate it both for its potential to be classified as dangerous waste and to not meet end users requirements.

**Street waste that is suspected to be dangerous waste should not be collected with other street waste.** Material in catch basins with obvious contamination (unusual color, staining, corrosion, unusual odors, fumes, and oily sheen) should be left in place or segregated until tested. Testing should be based on probable contaminants. Street waste that is suspected to be dangerous waste should be collected and handled by someone experienced in handling dangerous waste. If potential dangerous waste must be collected because of emergency conditions, or if the waste becomes suspect after it is collected, it should be handled and stored separately until a determination as to proper disposal is made. Street waste treatment and storage facilities should have separate "hot load" storage areas for such waste. **Dangerous Waste** includes street waste known and suspected to be dangerous waste. This waste must be handled following the Dangerous Waste Regulations (Chapter 173-303 WAC) unless testing determines it is not dangerous waste.

**Spills should be handled by trained specialists.** Public works maintenance crews and private operators conducting street sweeping or cleaning catch basins should have written policies and procedures for dealing with spills or suspected spill materials. Emergency Spill Response telephone numbers should be immediately available as part of these operating policies and procedures.

**The end recipient of street waste must be informed of its source and may have additional requirements for its use or testing that are not listed here.** This document is based primarily on average street waste's chemical constituents and their potential affect on human health and the environment. There are physical constituents (for example, broken glass or hypodermic needles) or characteristics (for example, fine grain size) that could also limit reuse options.

Additional treatment such as drying, sorting, or screening may also be required, depending on the needs and requirements of the end user.

**Street waste treatment and storage facilities owned or operated by governmental agencies should be made available to private waste collectors and other governmental agencies on a cost recovery basis.** Proper street waste collection and disposal reduces the amount of waste released to the environment. The operators of street waste facilities should restrict the use of their facilities to certified and/or licensed waste collectors who meet their training and liability requirements.

**The use of street waste solids under this guidance should not lead to designation as a hazardous waste site, requiring cleanup under MTCA.** Exceeding MTCA Method A unrestricted land use cleanup levels in street waste and products made from street waste, does not automatically make the site where street waste is reused a cleanup site. A site is reportable only if "-a release poses a threat to human health or the environment-" (Model Toxic Control Act). The reuse options proposed below are designed to meet the condition of not posing a threat to human health or the environment.

**Testing of street waste solids will generally be required as part of a plan of operation that includes procedures for characterization of the waste.** Testing frequency, numbers of samples, parameters to be analyzed, and contaminant limit criteria should all be provided as part of an approved plan of operation. Tables D.4 and D.5 below provide some recommended parameters and sampling frequencies for piles of street waste solids from routine street maintenance. These are provided as guidance only, and are intended to assist the utility and the local health department in determining appropriate requirements. Sampling requirements may be modified, over time, based on accumulated data. When the material is from a street waste facility or an area that has never been characterized by testing, the test should be conducted on a representative sample before co-mingling with other material. Testing in these instances would be to demonstrate that the waste does not designate as dangerous waste and to characterize the waste for reuse. At a minimum, the parameters in Table D.4 are recommended for these cases. Note that it will generally not be necessary to conduct TCLP analyses when the observed values do not exceed the recommended values in Table D.4. Table D.6 illustrates some observed relationships between total metals and TCLP metals values.

For further information on testing methods and sampling plans, refer to:

- SW 846 (US EPA, Office of Solid Waste, Test Methods for Evaluating Solid Wastes, 3rd Ed.) and
- Standard Methods for the Examination of Water and Wastewater (American Public Health Association, et al., 18th Edition 1992)

**For street waste not exceeding the suggested maximum values in Table D.4, the following street waste solids reuse and disposal options are recommended:**

- Street sweepings that consist primarily of leaves, pine needles and branches, and grass cuttings from mowing grassy swales can be composted. Litter and other foreign material must be removed prior to composting or the composting facility must provide for such removal as part of the process. The screened trash is solid waste and must be disposed of at an appropriate solid waste handling facility.



- Coarse sand screened from street sweeping after recent road sanding, may be reused for street sanding, providing there is no obvious contamination from spills. The screened trash is solid waste and must be disposed of at an appropriate solid waste handling facility.
- Roadside ditch cleanings, not contaminated by a spill or other release and not associated with a stormwater treatment system such as a bioswale, may be screened to remove litter and separated into soil and vegetative matter (leaves, grass, needles, branches, etc.). The soils from these activities are not generally regulated as solid waste. Ditching material that may be contaminated must be stored, tested and handled in the same manner as other street waste solids. It is the generator's responsibility to visually inspect and otherwise determine whether the materials may be contaminated.
- Construction street wastes - solids collected from sweeping or in storm water treatment systems at active construction sites - may be placed back onto the site that generated it, or managed by one of the methods listed below, provided that it has not been contaminated as a result of a spill. For concrete handling at construction site, refer to BMP C151 in Volume II, Construction Stormwater Pollution Prevention.
- Screened street waste soils may be used as feedstock materials for topsoil operations. This option should be reserved for street waste soils with very low levels of contaminants. Diluting street waste soils with clean soils or composted material must not be used as a substitute for treatment or disposal. There may be physical contaminants (for example, glass, metal, nails, etc.) in street waste that cannot be entirely screened from the waste. Where present, these contaminants in street waste could preclude its use as feedstock material for topsoil operations.
- Fill in parks, play fields, golf courses and other recreational settings, where direct exposure by the public is limited or prevented. One way to accomplish is to cover the fill with sod, grass or other capping material to reduce the risk of soil being ingested. The level of contaminants in the street waste must be evaluated to ensure that the soils meet the definition of clean soils when used in this manner.
- Fill in commercial and industrial areas, including soil or top dressing for use at industrial sites, roadway medians, airport infields and similar sites, where there is limited direct human contact with the soil, and the soils will be stabilized with vegetation or other means. The level of contaminants in the street waste must be evaluated to ensure that the soils meet the definition of clean soils when used in this manner.
- Top dressing on roadway slopes, road or parking lot construction material and road subgrade, parking lot subgrade, or other road fill. The level of contaminants in the street waste must be evaluated to ensure that the soils meet the definition of clean soils when used in this manner.
- Daily cover or fill in a permitted municipal solid waste landfill, provided the street waste solids have been dewatered. Street waste solids may be acceptable as final cover during a landfill closure. The local health department and landfill operator should be consulted to determine conditions of acceptance.
- Treatment at a permitted contaminated soil treatment facility.
- Recycling through incorporation into a manufactured product, such as Portland cement, prefab concrete, or asphalt. The facility operator should be consulted to determine conditions of acceptance.
- Other end-use as approved by the local health department

- Disposal at an appropriate solid waste handling facility.

**For street waste that exceed the suggested maximum values in Table D.4, the following street waste solids reuse and disposal options are recommended:**

- Treatment at a permitted contaminated soil treatment facility.
- Recycling through incorporation into a manufactured product, such as Portland cement, prefab concrete, or asphalt. The facility operator should be consulted to determine conditions of acceptance.
- Other end-use as approved by the local health department
- Disposal at an appropriate solid waste handling facility.

## **Street Waste Liquids**

**Street waste collection should emphasize solids in preference to liquids.** Street waste solids are the principal objective in street waste collection and are substantially easier to store and treat than liquids.

**Street waste liquids require treatment and/or must follow location limitations before their discharge.** Street waste liquids usually contain high amounts of suspended and total solids and adsorbed metals. Treatment requirements depend on the discharge location.

**Discharges to sanitary sewer and storm sewer systems must be approved by the entity responsible for operation and maintenance of the system.** Ecology will not generally require waste discharge permits for discharge of stormwater decant to sanitary sewers or to stormwater treatment BMPs constructed and maintained in accordance with Ecology's Stormwater Management Manual for Western Washington. (See Volume 5 for further detail).

**The following disposal options are recommended, in order of preference, for catch basin decant liquid and for water removed from stormwater treatment facilities.**

Under the Municipal General Permit, municipalities are required to use this guidance in determining appropriate means of dealing with street wastes from stormwater maintenance activities. Your regional Department of Ecology water quality staff can help you with treatment standards and permit requirements for your particular situation.

**Discharge of catch basin decant liquids to a municipal sanitary sewer connected to a Public Owned Treatment Works (POTW) is the preferred disposal option.** Discharge to a municipal sanitary sewer requires the approval of the sewer authority. Street waste liquids discharged to a POTW may be treated at a combined street waste liquid and solid facility (decant facility) or at separate liquids only facilities. These liquid only facilities may consist of modified type 2 catch basins (with a flow restrictor or oil/water separator) or water quality vaults, strategically located through the sanitary collection system. These should provide 24-hour detention for the expected volumes and should be constructed and operated to ensure that the decant discharge does not resuspend sediments. Sewer authorities should require periodic sampling and decant facility operators should test their waste effluent on a regular basis, but street waste decant liquid should meet the most restrictive local limits with 24 hours of undisturbed gravity settling. Overnight settling is more practical and will likely meet most local

pretreatment requirements. (See Table D.9 *Catch Basin Decant Values Following Settling* for typical catch basin decant values from King County's decant facility at Renton).

State and local regulations generally prohibit discharge of stormwater runoff into sanitary sewers, to avoid hydraulic overloads and treatment performance problems. The volume of storm water discharged from catch basins and small stormwater treatment facilities is generally not sufficient to be a problem, provided the discharge point is properly selected and designed.

**Stormwater removed from catch basins and stormwater treatment wetvaults may be discharged into a Basic or Enhanced Stormwater Treatment BMP.**

Decant liquid collected from cleaning catch basins and stormwater treatment wetvaults may be discharged back into the storm sewer system under the following conditions:

- The preferred disposal option of discharge to sanitary sewer is not reasonably available, **and**
- The discharge is to a Basic or Enhanced Stormwater Treatment Facility (See Volume V, Chapters 3 and 4), **and**
- The storm sewer system owner/operator has granted approval and has determined that the treatment facility will accommodate the increased loading.

Pretreatment may be required to protect the treatment BMP.

Reasonably available will be determined by the stormwater utility and by the circumstances, including such factors as distance, time of travel, load restrictions, and capacity of the stormwater treatment facility. Some jurisdictions may choose not to allow discharge back to the storm sewer system. Currently King County does not allow such discharges, under King County Code 9.12 – Water Quality.

**Discharge back into the storm sewer is an acceptable option, under certain conditions:**

- Other practical means are not reasonably available, **and**
- Pretreatment is provided by discharging to a modified type 2 catch basin (with a flow restrictor or oil/water separator) or water quality vault, **and**
- The discharge is upstream of a basic or enhanced stormwater treatment BMP, **and**
- The storm sewer system owner/operator has granted approval.

Other practical means includes the use of decanting facilities and field decant sites that discharge to sanitary sewers or discharge to an approved stormwater treatment BMP.

Limited field testing of flocculent aids has been conducted. While the use of flocculent aids is promising, sufficient testing has not been conducted to allow approval of any specific product or process. In general, the following conditions must be met for flocculent use to be approved:

- The flocculent must be non-toxic under circumstances of use and approved for use by the Department of Ecology
- The decant must be discharged to an approved basic or enhanced stormwater treatment BMP, with sufficient capacity and appropriate design to handle the anticipated volume and pollutant loading

- The discharge must be approved by the storm sewer system owner/operator.

**Water removed from stormwater ponds, vaults and oversized catch basins may be returned to storm sewer system.** Stormwater ponds, vaults and oversized catch basins contain substantial amounts of liquid, which hampers the collection of solids and pose problems if the removed waste must be hauled away from the site. Water removed from these facilities may be discharged back into the pond, vault or catch basin provided:

- Clear water removed from a stormwater treatment structure may be discharged directly to a downgradient cell of a treatment pond or into the storm sewer system.
- Turbid water may be discharged back into the structure it was removed from if:
  - The removed water has been stored in a clean container (eductor truck, Baker tank or other appropriate container used specifically for handling stormwater or clean water) and
  - There will be no discharge from the treatment structure for at least 24 hours.
- The discharge must be approved by the storm sewer system owner/operator.

Vegetation management and structural integrity concerns sometimes require that the ponds be refilled as soon after solids removal as possible. For ponds and other systems relying on biological processes for waste treatment, it is often preferable to reuse at least some portion of the removed water.

## Site Evaluation

**A site evaluation is suggested as method to identify spill sites or locations that are more polluted than normal.**

The site evaluation will aid in determining if waste should be handled as dangerous waste and in determining what to test for if dangerous waste is suspected. The site evaluation will also help to determine if the waste does not meet the requirements of the end users.

There are three steps to a site evaluation:

1. An **historical review** of the site for spills, previous contamination and nearby toxic cleanup sites and dangerous waste and materials.

The historical review will be easier if done on an area wide basis prior to scheduling any waste collection. The historical review should be more thorough for operators who never collected waste at a site before. At a minimum, the historical review should include operator knowledge of the area's collection history or records kept from previous waste collections.

Private operators should ask the owner of the site for records of previous contamination and the timing of the most recent cleaning. Ecology's Hazardous Substance Information Office maintains a Toxic Release Inventory and a "Facility Site" web page, tracking more than 15,000 sites. This information is available through the Internet at <http://www.wa.gov/ecology/iss/fsweb/fshome.html> or by calling a toll-free telephone number (800-633-7585). The web page allows anyone with web-access to search for facility information by address, facility name, town, zip code, and SIC code, etc. It lists why the Department of Ecology is tracking each one (NPDES, TSCA, RCRA, Clean Air Act, etc.), as well as who to call within Ecology to find out more about the given facility.

2. An **area visual inspection** for potential contaminant sources such as a past fire, leaking tanks and electrical transformers, and surface stains.

The area around the site should be evaluated for contaminant sources prior to collection of the waste. The area visual inspection may be done either as part of multiple or as single site inspections. If a potential contaminant source is found, the waste collection should be delayed until the potential contaminant is assessed.

A second portion of the area visual inspection is a subjective good housekeeping evaluation of the area. Locations with poor housekeeping commonly cut corners in less obvious places and should be inspected in greater detail for illegal dumping and other contamination spreading practices.

3. **A waste and container inspection** before and during collection.

The inspection of the waste and catch basin or vault is the last and perhaps most critical step in the site evaluation.

For example, if the stormwater facility has an unusual color in or around it, then there is a strong possibility that something could have been dumped into it. Some colors to be particularly wary of are yellow-green from antifreeze dumping and black and/rainbow sheen from oil and/or grease dumping. In addition, if any staining or corrosion is observed, then a solvent may have been dumped.

Fumes are also good indicators of potential dangerous or dangerous waste. Deliberate smelling of catch basins should be avoided for worker safety, but suspicious odors may be encountered from catch basins thought to be safe. Some suspicious odors are rotten eggs (hydrogen sulfide is present), gasoline or diesel fumes, or solvent odors. If unusual odors are noted, contact a dangerous waste inspector before cleaning the basin.

*Finally, operator experience is the best guide to avoid collection of contaminated waste.*

**Table C.1 - Typical TPH Levels in Street Sweeping and Catch Basin Solids**

Reference	Street Sweeping (mg/kg)	Catch Basin Solid (mg/kg)
Snohomish County (1) (Landau 1995)	390 – 4300	
King County (1) (Herrera 1995)		123 – 11049 (Median 1036)
Snohomish County & Selected Cities (1) (W & H Pacific, 1993)	163 - 1500 (Median 760)	163 – 1562 (Median 760)
City of Portland (2) (Bresch)		MDL – 1830 (Median – 208)
Oregon (1) (Collins; ODOT 1998)	1600 – 2380	
Oregon (3) (Collins; ODOT 1998)	98 - 125	

(1) Method WTPH 418.1; does not incorporate new methods to reduce background interference due to vegetative material

(2) Method NWTPH-Dx

(3) Method WTPH – HCID

**Table C.2 - Typical c-PAH Values in Street Waste Solids and Related Materials**

Sample Source Analyte	City of Everett					WSDOT	
	Street Sweepings	Soil	3-Way Topsoil	Vactor Solids	Leaf & Sand	Sweepings – Fresh	Sweepings Weathered
Benzo(a)anthracene	0.1U	0.076U	0.074U	0.21	0.45	0.56	0.40
Chrysene	0.14	0.09	0.074U	0.32	0.53	0.35	0.35
Benzo(b)fluoranthene	0.11	0.076U	0.074U	0.27	0.52	0.43	0.51
Benzo(k)fluoranthene	0.13	0.076U	0.074U	0.25	0.38	0.39	0.40
Benzo(a)pyrene	0.13	0.076U	0.074U	0.26	0.5	0.41	0.33U
Indeno(1,2,3-cd)pyrene	0.1U	0.076U	0.074U	0.19	0.39	NR	NR
Dibenzo(a,h)anthracene	0.1U	0.076U	0.074U	0.081	0.12	0.39	0.33U
Revised MTCA	0.215	0.134	0.134	0.388	0.727	0.708	0.597
Benzo(a)pyrene [ND=PQL]							
Benzo(a)pyrene [ND=1/2 PQL]	0.185	0.069	0.067	0.388	0.727	0.708	0.366
Benzo(a)pyrene [See below]	0.185	0.069	0	0.388	0.727	0.708	0.366
Benzo(a)pyrene [ND=0]	0.155	0.001	0	0.388	0.727	0.708	0.135

\*If the analyte was not detected for any PAH, then ND=0; If analyte was detected in at least 1 PAH, then ND=1/2PQL; If the average concentration (using ND=1/2 PQL) is greater than the maximum detected value, then ND=Maximum value.

The new Method A soil cleanup level for unrestricted land use is 0.1 mg/Kg for BAP. (WAC 173-340-900, Table 740-1)

The new Method A soil cleanup level for industrial properties is 2 mg/Kg for BAP. (WAC 173-340-900, Table 745-1)

**Table C.3 - Typical Metals Concentrations in Catch Basin Sediments**

PARAMETER	Ecology 1993	Thurston 1993	King County 1995	King County 1995
METALS; TOTAL (mg/kg)	(Min – Max)	(Min – Max)	(Min - Max)	Mean
As	<3 -- 24	.39 -- 5.4	4 – 56	0.250
Cd	0.5 -- 2.0	< 0.22 -- 4.9	0.2 – 5.0	0.5
Cr	19 -- 241	5.9 -- 71	13 - 100	25.8
Cu	18 -- 560	25 -- 110	12 - 730	29
Pb	24 -- 194	42 -- 640	4 – 850	80
Ni	33 -- 86	23 -- 51	14 – 41	23
Zn	90 -- 558	97 -- 580	50 – 2000	130
Hg	.04 -- .16	.024 -- .193		

**Table C.4 - Recommended Parameters and Suggested Values for Determining Reuse & Disposal Options**

Parameter	Suggested Maximum Value
Arsenic, Total	20.0 mg/kg (a)
Cadmium, Total	2.0 mg/kg (b)
Chromium, Total	42 mg/kg (c)
Lead, total	250 mg/kg (d)
Nickel	100 mg/kg (e)
Zinc	270 mg/kg (e)
Mercury (Inorganic)	2.0 mg/kg (f)
PAHs (Carcinogenic)	0.1 – 2.0 mg/kg (see Note at (g) below)
TPH (Heavy Fuel Oil)	200 - 460 mg/kg (see Note at (h) below)
TPH (Diesel)	200 – 460 mg/kg (see Note at (h) below)
TPH (Gasoline)	100 mg/kg (i)
Benzene	0.03 mg/kg (i)
Ethylbenzene	6 mg/kg (i)
Toluene	7 mg/kg (i)
Xylenes (Total)	9 mg/kg (i)

(a) Arsenic: from MTCA Method A - Table 740-1: Soil cleanup levels for unrestricted land uses

(b) Cadmium: from MTCA Method A – Table 740-1: Soil cleanup levels for unrestricted land uses s.

(c) Chromium; from MTCA Method A - Table 740-1: Soil cleanup levels for unrestricted land uses

(d) Lead; from MTCA Method A – Table 740-1: Soil cleanup levels for unrestricted land uses

(e) Nickel and Zinc; from MTCA Table 749-2: Protection of Terrestrial Plants and Animals

(f) Mercury; from MTCA Method A – Table 740-1: Soil cleanup levels for unrestricted land uses

(g) PAH-Carcinogenic; from MTCA Method A – Table 740-1: Soil cleanup levels for unrestricted land uses and Table 745-1, industrial properties, based on cancer risk via direct contact with contaminated soil (ingestion of soil) in residential land use situations and commercial/industrial land uses. Note: The local health department may permit higher levels as part of a Plan of Operation, where they determine that the proposed end use poses little risk of direct human contact or ingestion of soil.

(h) TPH: from MTCA Tables 749-2 & 749-3: Protection of Terrestrial Plants and Animals. Values up to 460 mg/kg may be acceptable where the soils are capped or covered to reduce or prevent exposure to terrestrial plants and animals. Where the laboratory results report no 'fingerprint' or chromatographic match to known petroleum hydrocarbons, the soils will not be considered to be petroleum contaminated soils.

(i) BETX; from MTCA Method A - Table 740-1: Soil cleanup levels for unrestricted land uses.

**Table C.5 - Recommended Sampling Frequency for Street Waste Solids**

Cubic Yards of Solids	Minimum Number of Samples
0 – 100	3
101 – 500	5
501 – 1000	7
1001 – 2000	10
>2000	10 + 1 for each additional 500 cubic yards

Modified from Ecology's Interim Compost Guidelines

**Table C.6 - Pollutants in Catch Basin Solids – Comparison to Dangerous Waste Criteria**

PARAMETER	Range of Values in Catch Basin Waste	Range of Values in Catch Basin Waste	Dangerous Waste Criteria
METALS	Total Metals (mg/kg)	TCLP Metals (mg/kg)	TCLP values (mg/l)
As	<3 – 56	< .02 - 0.5	5.0
Cd	<.22 – 5	.0002 - .03	1.0
Cr	5.9 - 241	.0025 - .1	5.0
Cu	12 - 730	.002 -- .88	none
Pb	4 - 850	.015 -- 3.8	5.0
Ni	23 - 86	< .01 -- .36	none
Zn	50 - 2000	.04 -- 6.7	none
Hg	.02 - .19	.0001 -- .0002	0.2

Data from Thurston County (Thurston County 1993), King County (Herrera 1995) and Ecology (Serdar; Ecology 1993).

**Table C.7 - Typical Catch Basin Decant Values Compared to Surface Water Quality Criteria**

PARAMETER	State Surface Water Quality Criteria		Range of Values Reported	Range of Values Reported
	Freshwater Acute (ug/l – dissolved metals)	Freshwater Chronic (ug/l – dissolved metals)	Total Metals (ug/l)	Dissolved Metals (ug/l)
Arsenic	360	190	100 – 43000	60 - 100
Cadmium*	2.73	0.84	64 - 2400	2 - 5
Chromium (total)			13 -- 90000	3 - 6
Chromium (III)*	435	141		
Chromium (VI)	0.5	10		
Copper*	13.04	8.92	81 -- 200000	3 - 66
Lead*	47.3	1.85	255 -- 230000	1 - 50
Nickel*	1114	124	40 -- 330	20 - 80
Zinc*	90.1	82.3	401 -- 440000	1900 - 61000
Mercury	2.10	.012	0.5 -- 21.9	

\*Hardness dependent; hardness assumed to be 75 mg/l



**Table C.8 - Typical Values for Conventional Pollutants in Catch Basin Decant**

PARAMETER	Ecology 1993	(Min - Max)	King County 1995	(Min - Max)
Values as mg/l; except where stated	Mean		Mean	
PH	6.94	6.18 - 7.98	8	6.18 - 11.25
Conductivity (umhos/cm)	364	184 - 1110	480	129 - 10,100
Hardness (mg/l CaCO3)	234	73 - 762		
Fecal Coliform (MPN/100 ml)	3000			
BOD	151	28 - 1250		
COD	900	120 - 26,900		
Oil & Grease	11	7.0 - 40	471	15 - 6242
TOC	136	49 - 7880	3670	203 - 30,185
Total Solids	1930	586 - 70,400		
Total Dissolved Solids	212	95 - 550		
Total Suspended Solids	2960	265 - 111,000		
Settleable Solids (ml/l/hr)	27	2 - 234	57	1 - 740
Turbidity (ntu)	1000	55 - 52,000	4673	43 - 78,000

**Table C.9 - Catch Basin Decant Values Following Settling<sup>1</sup>**

Parameter; Total Metals in mg/l	Portland – Inverness Site Min - Max	King County - Renton Min - Max	METRO Pretreatment Discharge Limits
Arsenic	.0027 - .015	< MDL – 0.12	4
Cadmium	.0009 - .0150	< MDL – 0.11	0.6
Chromium	.0046 - .0980	.017 – .189	5
Copper	.015 - .8600	.0501 – .408	8
Lead	.050 – 6.60	.152 – 2.83	4
Nickel	.0052 - .10	.056 - .187	5
Silver	.0003 - .010	< MDL	3
Zinc	.130 – 1.90	.152 – 3.10	10
Settleable Solids; ml/L	No Data	.02 - 2	7
Nonpolar FOG	5.7 - 25	5 - 22	100
Ph (std)	6.1 – 7.2	6.74 – 8.26	5.0 - 12.0
TSS	2.8 - 1310		
Recorded Total Monthly Flow; Gallons	Data not available	31,850 - 111,050	
Recorded Max. Daily Flow; Gallons	Data not available	4,500 - 18,600	25,000 GPD
Calculated Average Daily Flow; GPD	Data not available	1517 - 5428	

<sup>1</sup> Data from King County's Renton Facility (data from 1998 – 1999) and the City of Portland's Inverness Site (data from 1999 – 2001); detention times not provided

## **Resource Materials – Management of Street Wastes**

---

Austin, City of, Removal Efficiencies of Stormwater Control Structures. Environmental and Conservation Services Department, 1990.

City of Portland Vactor Waste Decant Data, Personal Communication with Katie Bretsch, April 2000

Campbell, Robert, Street Waste Characterization Testing Program, VTP-1, Snohomish County Public Works Maintenance & Operations Division, March 1994.

Collins, Jay, Oregon Department of Transportation, Street Waste Issues and Options FHWA-OR-RD-99-05, July 1998

Ecology, Interim TPH Policy, Publication N. ECY 97-600, 1997.

Ecology, Analytical Methods for Petroleum Hydrocarbons, Publication No. ECY 97-602, June 1997.

Ecology, Dangerous Waste Regulations, Chapter 173-303 WAC.

Ecology, Discussion Draft - Recommendations for Management of Street Waste, June 1999

Ecology, Draft Minimum Functional Standards for Solid Waste Handling, Chapter 173-350 WAC, December 1999.

Ecology, Guidance for Remediation of Petroleum Contaminated Soils, pub 91-30, 1994.

Ecology, Minimum Functional Standards for Solid Waste Handling, Chapter 173-304 WAC.

Ecology, Model Toxics Control Act (MTCA) Cleanup Regulations, Chapter 173-340 WAC

Ecology, Water Quality Standards For Surface Waters of the State of Washington, Chapter 173-201A.

Hazardous Waste Management Act of 1976, Chapter 70.105 RCW

Herrera Environmental Consultants, Inc., King County Maintenance Waste Disposal Characterization Study, prepared for King County Surface Water Management Division, January Draft, 1995.

Herrera Environmental Consultants, Inc., Street Truck Operations and Disposal Practices, 1991.

Holz, Thomas, Street Waste Disposal, Thurston County, Washington: Final Engineering Report and One Year Certification, Grant No. Tzx 91-129, May, 1994.

Jacobson, Michael, Data Summary of Catch Basin and Vactor Waste Contamination in Washington State, Final Report, Center for Urban Water Resources, University of Washington, 1993.

- King County, Vactor Waste Disposal Plan, King County Surface Water Management Division, Water Quality Unit, 1994.
- King County's Renton Facility Decant Data, Personal Correspondence with Jerry Creek, and Susan Turner, June 1999
- Landau Associates, Inc. Snohomish County Street Waste Characterization, Final Report, December 1995
- Pitt, R. and P. Bissonnette, Bellevue Urban Runoff Program; Summary Report, Prepared for City of Bellevue Storm and Surface Water Utility, 1984.
- Pitt, R., 1985, Characterizing and Controlling Urban Runoff through Street and Sewer Cleaning, EPA/600/2-85/038
- Pond, Rodney, South Base Pond Report - The Response of Wetland Plants to Stormwater Runoff From a Transit Base, Municipality of Metropolitan Seattle Publication 775, 1993.
- Schueler, Thomas, R., Pollutant Dynamics of Pond Muck, Wat. Prot. Techniques, 1 (2). Summer 1994
- Serdar, Dave, Ecology, Contaminants in Vactor Truck Wastes, April 1993
- Thurston County Environmental Health Division, (Environmental Health Division-Unpublished data), 1993
- Thurston County Environmental Health Division, Report on Street Facility Monitoring Grant Tax No. 91-129, April 1993
- TYMCO, Inc. Best Management Practices - Street Sweeping, Waco, Texas, 1993.
- US Environmental Protection Agency, "Methods for Evaluating Solid Waste, Physical/ Chemical
- US Environmental Protection Agency, Test Methods for Evaluating Solid Wastes, (SW-846), 3<sup>rd</sup> Edition, 1986.
- W&H Pacific, Inc., Street and Street Sweeping Waste Characteristics Snohomish County, Washington, February 1994.

## Volume IV References

---

- CH2M Hill, Comments on Washington State Department of Ecology Draft Publication 99-11 through 99-15, Soil Improvement Project Engineering Report for Snohomish County, February 2000.
- City of Tacoma, Stormwater Management Manual, Volume II, Stormwater Pollution Prevention Manual: A Guide to Best Management Practices for Industries, Businesses and Homeowners, August 1999.
- Daar, Olkowski & Olkowski, IPM Training Manual for Gardeners, 1992.
- Daar, Sheila, Least Toxic Pest Management for Lawns, Integral Resource Center, Berkeley, CA 94707; 1992.
- Field, Richard and Pitt, Robert, E., et. al., Urban Wet-weather Flows, Water Environment Research Literature Review, 1997.
- Gaus, J., High Use/Oil Control Decision Paper-Second Draft, King County Surface Water Management, 1994.
- King County Surface Water Management, Best Management Practices for Businesses, July 1995.
- Olkowski, William, Helga Olkowski and Sheila Daar, What is IPM? In Common Sense Pest Control, Volume 3, summer 1988.
- Perry, George et al, A Comprehensive IPM Program, King County Local Hazardous Waste Management Program, November 7, 2000.
- Pitt, Robert, Urban Stormwater Toxic Pollutants: Assessment, Sources, and Treatability, Water Environment Research, May/June 1995.
- Sartor, J.D. and B.G. Boyd, Water Pollution Aspects of Street Surface Contaminants, EPA-R2-72-081, November 1972, P.7.
- Schueler, Thomas, R., Comparative Pollutant Removal Capability of Urban BMPs: A Reanalysis, Watershed Protection Techniques, June 1997.
- Silverman, Gary S. and Michael K. Stenstrom, Source Control of Oil and Grease in an Urban Area, in Design of Urban Runoff Quality Controls, ASCE, 1988.
- Standard Industrial Classification Manual, Office of Management and Budget, 1987.
- Strecker, Eric, W., et. al., Analysis of Oregon Urban Runoff Water Quality Monitoring Data Collected from 1990 to 1996, The Oregon Association of Clean Water Agencies, February 1997 Draft.
- Sutherland, Roger, High Efficiency Sweeping as an Alternative to the Use of Wet Vaults for Stormwater Treatment, 1998.
- Tri-County Road Maintenance ESA Technical Working Group, under the Tri-County ESA Response Effort (King, Pierce, Snohomish and other municipalities and entities in Washington State), Regional Road Maintenance Endangered Species Act – Program Guidelines, under final review 2002.

U.S. Environmental Protection Agency, Multi-sector Stormwater Permit and Fact Sheet, September 1995.

U.S. Environmental Protection Agency, Results of the Nationwide Urban Runoff Program, December 1983.

Washington State Department of Ecology, Implementation Guidance for the Ground Water Quality Standards, publication 96-02, 1996.

Washington Department of Ecology, NPDES and State Waste Discharge Baseline General Permit for Stormwater Discharge Associated with Industrial Activities, November 18, 1995.

Washington State Department of Ecology, Stormwater Management Manual for Western Washington, August 2001.

Washington State Department of Ecology, Techniques for Dust Prevention and Suppression, publication #96-433, 1996.

# **City of Tacoma Surface Water Management Manual**

---

## **Volume V Runoff Treatment BMPs**

Prepared by:

Tacoma Public Works  
Environmental Services

January 2003



# Table of Contents – Volume V

---

<b>Chapter 1 – Introduction</b> .....	<b>1-1</b>
1.1 Purpose of this Manual .....	1-1
1.2 Content and Organization of this Volume .....	1-1
1.3 How to Use this Volume.....	1-1
1.4 Runoff Treatment Facilities .....	1-2
1.4.1 General Considerations.....	1-2
1.4.2 Maintenance .....	1-2
1.4.3 Treatment Methods .....	1-2
<b>Chapter 2 – Treatment Facility Selection Process</b> .....	<b>2-1</b>
2.1 Step-by-Step Selection Process for Treatment Facilities.....	2-1
2.2 Other Treatment Facility Selection Factors .....	2-8
<b>Chapter 3 – Treatment Facility Menus</b> .....	<b>3-1</b>
3.1 Guide to Applying Menus .....	3-1
3.2 Oil Control Menu.....	3-2
3.3 Phosphorus Treatment Menu.....	3-3
3.4 Enhanced Treatment Menu.....	3-4
3.5 Basic Treatment Menu.....	3-6
<b>Chapter 4 – General Requirements for Storm Water Facilities</b> .....	<b>4-1</b>
4.1 Design Volume and Flow .....	4-1
4.1.1 Water Quality Design Storm Volume .....	4-1
4.1.2 Water Quality Design Flow Rate .....	4-1
4.1.3 Flows Requiring Treatment .....	4-2
4.2 Sequence of Facilities.....	4-4
4.3 Setbacks, Slopes, and Embankments.....	4-5
4.3.1 Setbacks .....	4-5
4.3.2 Side Slopes and Embankments .....	4-6
4.4 Facility Liners.....	4-6
4.4.1 General Design Criteria.....	4-6
4.4.2 Design Criteria for Treatment Liners.....	4-7
4.4.3 Design Criteria for Low Permeability Liner Options .....	4-8
4.5 Hydraulic Structures.....	4-9
4.5.1 Flow Splitter Designs .....	4-9
4.5.2 Flow Spreading Options .....	4-11



4.5.3	Outfall Systems.....	4-13
4.6	Maintenance Standards for Drainage Facilities .....	4-15
<b>Chapter 5</b>	<b>– On-Site Storm Water Management .....</b>	<b>5-1</b>
5.1	Purpose .....	5-1
5.2	Application .....	5-1
5.3	Best Management Practices for On-Site Surface Water Management .....	5-1
5.3.1	Dispersion and Soil Quality BMPs.....	5-3
BMP T5.10	Downspout Dispersion.....	5-3
BMP T5.11	Concentrated Flow Dispersion .....	5-6
BMP T5.12	Sheet Flow Dispersion.....	5-7
BMP T5.13	Post-Construction Soil Quality and Depth .....	5-8
5.3.2	Site Design BMPs .....	5-10
BMP T5.20	Preserving Natural Vegetation .....	5-10
BMP T5.21	Better Site Design.....	5-12
5.3.3	Other Practices .....	5-15
BMP T5.30	Full Dispersion.....	5-15
BMP T5.31	Vegetated Rooftops (Green Roofs).....	5-18
BMP T5.32	Cisterns .....	5-20
BMP T5.33	Concave Vegetated Surfaces .....	5-21
BMP T5.34	Multiple Small Basins.....	5-22
BMP T5.35	Engineered Soil/Landscape Systems.....	5-23
BMP T5.36	Soil Compaction Protection and Mitigation.....	5-25
5.3.4	Permeable/Porous Pavements.....	5-26
BMP T5.40	Porous Concrete and Porous Asphalt .....	5-26
BMP T5.41	Porous Pavers .....	5-30
BMP T5.42	Permeable Interlocking Concrete Pavement .....	5-32
<b>Chapter 6</b>	<b>– Pretreatment .....</b>	<b>6-1</b>
6.1	Purpose .....	6-1
6.2	Application .....	6-1
6.3	Best Management Practices (BMPs) for Pretreatment.....	6-1
BMP T6.10	Presettling Basin .....	6-2
<b>Chapter 7</b>	<b>– Infiltration and Bio-infiltration Facilities.....</b>	<b>7-1</b>
7.1	Purpose .....	7-1
7.2	Application .....	7-1
7.3	General Considerations .....	7-2

7.3.1	Site Characterization Criteria .....	7-2
7.3.2	Design Infiltration Rate Determination .....	7-5
7.3.3	Site Suitability Criteria (SSC) .....	7-9
7.3.4	General Information for Infiltration Basins, Trenches, and Bio-infiltration Swales .....	7-12
7.4	Best Management Practices (BMPs) for Infiltration and Bio-infiltration Treatment .....	7-15
	BMP T7.10 Infiltration Basins .....	7-16
	BMP T7.20 Infiltration Trenches .....	7-17
	BMP T7.30 Bio-infiltration Swales.....	7-19
<b>Chapter 8 – Sand Filtration Treatment Facilities.....</b>		<b>8-1</b>
8.1	Purpose .....	8-1
8.2	Description.....	8-1
8.3	Performance Objectives.....	8-1
8.4	Applications and Limitations.....	8-1
8.5	Site Suitability .....	8-2
8.6	Design Criteria .....	8-2
8.7	Construction Criteria .....	8-9
8.8	Maintenance Criteria.....	8-9
	BMP T8.10 Sand Filter Vault.....	8-11
	BMP T8.20 Linear Sand Filter .....	8-13
<b>Chapter 9 – Biofiltration Treatment Facilities .....</b>		<b>9-1</b>
9.1	Purpose .....	9-1
9.2	Applications .....	9-1
9.3	Site Suitability .....	9-1
9.4	Best Management Practices .....	9-1
	BMP T9.10 Basic Biofiltration Swale .....	9-2
	BMP T9.20 Wet Biofiltration Swale .....	9-13
	BMP T9.30 Continuous Inflow Biofiltration Swale.....	9-16
	BMP T9.40 Basic Filter Strip .....	9-17
	BMP T9.50 Narrow Area Filter Strip.....	9-19
<b>Chapter 10 – Wetpool Facilities .....</b>		<b>10-1</b>
10.1	Purpose .....	10-1
10.2	Application .....	10-1
10.3	Best Management Practices (BMPs) for Wetpool Facilities.....	10-1

BMP T10.10 Wetponds - Basic and Large .....	10-2
BMP T10.20 Wetvaults .....	10-11
BMP T10.30 Stormwater Treatment Wetlands .....	10-17
BMP T10.40 Combined Detention and Wetpool Facilities .....	10-22
<b>Chapter 11 – Oil and Water Separators .....</b>	<b>11-1</b>
11.1 Purpose of Oil and Water Separators.....	11-1
11.2 Description.....	11-1
11.3 Performance Objectives.....	11-1
11.4 Applications/Limitations.....	11-1
11.5 Site Suitability .....	11-2
11.6 Design Criteria-General Considerations.....	11-2
11.7 Oil and Water Separator BMPs .....	11-3
BMP T11.10 API (Baffle type) Separator Bay.....	11-4
BMP T11.11 Coalescing Plate (CP) Separator Bay.....	11-6
<b>Chapter 12 – Emerging Technologies .....</b>	<b>12-1</b>
12.1 Background.....	12-1
12.2 Ecology Role in Evaluating Emerging Technologies .....	12-1
12.3 Acceptable Evaluation Protocol (APWA Task Committee, 1999) .....	12-2
12.4 Assessing Levels of Development of Emerging Technologies.....	12-2
12.5 Examples of Emerging Technologies for Stormwater Treatment and Control	12-2
12.5.1 Media Filters.....	12-3
12.5.2 Amended Sand Filters .....	12-4
12.5.3 Catch Basin Inserts (CBI).....	12-5
12.5.4 Manufactured Storm Drain Structures .....	12-6
12.5.5 High Efficiency Street Sweepers .....	12-7
<b>References .....</b>	<b>Ref-1</b>
<b>Appendices</b>	
Appendix V-A	Basic Treatment Receiving Waters
Appendix V-B	Procedure for Conducting a Pilot Infiltration Test
Appendix V-C	Geotextile Specifications
Appendix V-D	Turbulence and Short-Circuiting Factor

## Tables

Table 2.1	Suggested Storm Water Treatment Options for New Development and Redevelopment Projects.....	2-9
Table 2.2	Ability of Treatment Facilities to Remove Key Pollutants .....	2-3
Table 2.3	Screening Treatment Facilities Based on Soil Type .....	2-3
Table 3.1	Treatment Trains for Phosphorus Removal.....	3-8
Table 3.2	Treatment Trains for Dissolved Metals Removal.....	3-8
Table 4.1	Ratio of 91% Flow Rate to 2-Year Frequency vs. Effective Impervious Area .....	4-37
Table 4.2	Treatment Facility Placement in Relation to Detention .....	4-38
Table 4.3	Lining Types Recommended For Runoff Treatment Facilities.....	4-39
Table 4.4	Sieve Sizes.....	4-39
Table 4.5	Rock Protection at Outfalls .....	4-40
Table 7.1	Recommended Infiltration Rates based on USDA Soil Textural Classification. ...	7-21
Table 7.2	Alternative Infiltration Rates Based on ASTM Gradation Testing. ....	7-21
Table 7.3	Correction Factors to be Used With In-Situ Infiltration Measurements to Estimate Long-Term Design Infiltration Rates.....	7-21
Table 8.1	Sand Medium Specification .....	8-14
Table 8.2	Clay Liner Specifications.....	8-14
Table 9.1	Sizing Criteria .....	9-21
Table 9.2	Guide for Selecting Degree of Retardance .....	9-22
Table 9.3	Guide for Selecting Maximum Permissible Swale Velocities for Stability.....	9-22
Table 9.4	Grass seed mixes suitable for biofiltration swale treatment areas .....	9-23
Table 9.5	Groundcovers and grasses suitable for the upper side slopes of a biofiltration swale in western Washington .....	9-23
Table 9.6	Recommended plants for wet biofiltration swale .....	9-24
Table 10.1	Emergent wetland plant species recommended for wetponds .....	10-26
Table 10.2	Distribution of depths in wetland cell .....	10-27

## Figures

Figure 2.1	Treatment Facility Selection Flow Chart.....	2-11
Figure 4.1	Flow Splitter, Option A.....	4-41
Figure 4.2	Flow Splitter, Option B.....	4-42
Figure 4.3	Flow Spreader Option A: Anchored Plate.....	4-43
Figure 4.4	Flow Spreader Option B: Concrete Sump Box.....	4-44
Figure 4.5	Flow Spreader Option C: Notched Curb Spreader.....	4-45
Figure 4.6	Flow Spreader Option D: Through-Curb Port.....	4-45
Figure 4.7	Pipe/Culvert Outfall Discharge Protection.....	4-46
Figure 4.8	Flow Dispersal Trench.....	4-47
Figure 4.9	Alternative Flow Dispersal Trench.....	4-48
Figure 4.10	Gabion Outfall Detail.....	4-49
Figure 4.11	Diffuser TEE (an example of energy dissipating end feature).....	4-50
Figure 4.12	Fish Habitat Improvement at New Outfalls.....	4-50
Figure 5.1	Typical Dispersion Trench.....	5-43
Figure 5.2	Standard Dispersion Trench with Notched Grade Board.....	5-44
Figure 5.3	Typical Downspout Splashblock Dispersion.....	5-45
Figure 5.4	Typical Concentrated Flow Dispersion for Steep Driveways.....	5-46
Figure 5.5	Sheet Flow Dispersion for Driveways.....	5-47
Figure 5.6	Porous Concrete Pavement Typical Section.....	5-48
Figure 5.7	Porous Asphalt Pavement Typical Section.....	5-48
Figure 5.8	Components of a Permeable Interlocking Concrete Pavement.....	5-49
Figure 5.9	Direct Flow into Subgrade.....	5-49
Figure 5.10	Collection and Disposal of Infiltration (Example 1).....	5-50
Figure 5.11	Collection and Disposal of Infiltration (Example 2).....	5-50
Figure 5.12	Treatment of Contaminated Flow.....	5-51
Figure 5.13	Slow Infiltration Disposal.....	5-51
Figure 5.14	Various Types Of Subdrainage Systems Using Geotextiles.....	5-52
Figure 7.1	USDA Textural Triangle.....	7-22
Figure 7.2	Example Infiltration Basin/Pond.....	7-23
Figure 7.3	Parking Lot Perimeter Trench Design.....	7-24
Figure 7.4	Infiltration Trench System.....	7-24
Figure 7.5	Median Strip Trench Design.....	7-25
Figure 7.6	Oversized Pipe Trench Design.....	7-25
Figure 7.7	Swale/Trench Design.....	7-26

Figure 7.8	Underground Trench with Oil/Grit Chamber .....	7-26
Figure 7.9	Observation Well Details.....	7-27
Figure 8.1	Sand Filtration Basin Preceded by Presettling Basin.....	8-15
Figure 8.2	Sand Filter with Pretreatment Cell.....	8-16
Figure 8.2	Sand Filter with Pretreatment Cell (cont).....	8-17
Figure 8.3	Sand Filter with Level Spreader .....	8-18
Figure 8.3	Sand Filter with Level Spreader (cont) .....	8-19
Figure 8.4a	Flow Splitter Option A .....	8-20
Figure 8.4b	Flow Splitter Option B .....	8-21
Figure 8.5	Example Isolation/Diversion Structure .....	8-22
Figure 8.6a	Sand Filter Vault .....	8-23
Figure 8.6b	Sand Filter Vault (cont) .....	8-24
Figure 8.7	Linear Sand Filter .....	8-25
Figure 9.1	Typical Swale Section.....	9-25
Figure 9.2	Biofiltration Swale Underdrain Detail.....	9-25
Figure 9.3	Biofiltration Swale Low-Flow Drain Detail.....	9-25
Figure 9.4	Swale Dividing Berm.....	9-26
Figure 9.5	Geometric Formulas for Common Swale Shapes .....	9-27
Figure 9.6	The Relationship of Manning's n with VR for Various Degrees of Flow Retardance (A-E) .....	9-28
Figure 9.7	Biofiltration Swale Access Features .....	9-28
Figure 9.8	Typical Filter Strip .....	9-30
Figure 9.9	Filter Strip Lengths for Narrow Right-of-Way.....	9-31
Figure 10.1a	Wetpond .....	10-28
Figure 10.1b	Wetpond .....	10-29
Figure 10.2	Headwater Depth For Smooth Interior Pipe Culverts With Inlet Control.....	10-30
Figure 10.3	Headwater Depth For Corrugated Pipe Culverts With Inlet Control .....	10-31
Figure 10.4	Critical Depth Of Flow For Circular Culverts.....	10-32
Figure 10.5	Circular Channel Ratios .....	10-33
Figure 10.6	Wetvault.....	10-34
Figure 10.7	Stormwater Wetland — Option One.....	10-35
Figure 10.8	Stormwater Wetland — Option Two.....	10-36
Figure 10.9	Combined Detention and Wetpond .....	10-37
Figure 10.10	Combined Detention and Wetpond (Continued).....	10-38
Figure 10.11	Alternative Configurations of Detention and Wetpool Areas.....	10-39

Figure 11.1	API (Baffle Type) Separator .....	11-8
Figure 11.2	Coalescing Plate Separator .....	11-9
Figure 11.3	Spill Control Separator (Not for treatment) .....	11-10
Figure 12.1	Vertical Media Filter .....	12-8
Figure 12.2	Vortex-enhanced settling mechanism .....	12-8
Figure 12.3	Vortex-enhanced Sedimentation and Media Filtration .....	12-9
Figure 12.4	Screen Separator .....	12-9
Figure 12.5	Engineered Cylindrical Sedimentation .....	12-10

# Chapter 1 – Introduction

---

## 1.1 Purpose of this Volume

Best Management Practices (BMPs) are schedules of activities, prohibitions of practices, maintenance procedures, managerial practices, or structural features that prevent or reduce adverse impacts to waters of Washington State. As described in Volume I of this surface water manual, BMPs for long-term management of storm water at developed sites can be divided into three main categories:

- BMPs addressing the amount and timing of storm water flows;
- BMPs addressing prevention of pollution from potential sources; and
- BMPs addressing treatment of runoff to remove sediment and other pollutants.

This volume of the surface water manual focuses on the third category, treatment of runoff to remove sediment and other pollutants at developed sites. The purpose of this volume is to provide guidance for selection, design, and maintenance of permanent runoff treatment facilities.

BMPs with respect to controlling storm water flows and control of pollutant sources are presented in Volumes III and IV, respectively.

## 1.2 Content and Organization of this Volume

Volume V of the surface water manual contains 12 chapters. Chapter 1 serves as an introduction and summarizes available options for treatment of storm water. Chapter 2 outlines a step-by-step process for selecting treatment facilities for new development and redevelopment projects. Chapter 3 presents treatment facility “menus” that are used in applying the step-by-step process presented in Chapter 2. These menus cover different treatment needs that are associated with different sites. Chapter 4 discusses general requirements for treatment facilities. Chapter 5 presents information regarding on-site storm water management BMPs. These BMPs are intended to infiltrate, disperse, or contain runoff on site, as well as to provide treatment. Chapters 6 through 11 provide detailed information regarding specific types of treatment identified in the menus. Chapter 12 discusses special considerations for emerging technologies for storm water treatment.

The Appendices to this volume contain more detailed information on selected topics described in the various chapters.

## 1.3 How to Use this Volume

This volume should be consulted to select specific BMPs for runoff treatment for inclusion in Stormwater Site Plans (see Volume I). After the Minimum Requirements have been identified from Volume I, this volume



can be used to select specific treatment facilities for permanent use at developed sites, and as an aid in designing and constructing these facilities.

## 1.4 Runoff Treatment Facilities

### 1.4.1 General Considerations

Runoff treatment facilities are designed to remove pollutants contained in storm water runoff. The pollutants of concern include sand, silt, and other suspended solids; metals such as copper, lead, and zinc; nutrients (e.g., nitrogen and phosphorous); certain bacteria and viruses; and organics such as petroleum hydrocarbons and pesticides. Methods of pollutant removal include sedimentation/settling, filtration, plant uptake, ion exchange, adsorption, and bacterial decomposition. Floatable pollutants such as oil, debris, and scum can be removed with separator structures.

### 1.4.2 Maintenance

Maintenance is required for all types of runoff treatment facilities. See Section 4.6 for maintenance standards for the treatment facilities discussed in this volume.

### 1.4.3 Treatment Methods

Methods used for runoff treatment facilities and common terms used in runoff treatment are discussed below:

- **Wetpools.** Wetpools can be designed to provide runoff treatment by allowing settling of particulates during quiescent conditions (sedimentation), by biological uptake, and by vegetative filtration. Wetpools may be single-purpose facilities or they may be combined with a detention pond or vault. If combined, the wetpool facility can often be stacked under the detention facility with little further loss of development area.
- **Biofiltration.** Biofiltration uses vegetation in conjunction with slow and shallow-depth flow for runoff treatment. As runoff passes through the vegetation, pollutants are removed through the combined effects of filtration, infiltration, and settling. These effects are aided by the reduction of the velocity of storm water as it passes through the biofilter. Biofiltration facilities include swales that are designed to convey and treat concentrated runoff at shallow depths and slow velocities, and filter strips that are broad areas of vegetation for treating sheet flow runoff.
- **Oil/Water Separation.** Oil/water separators remove oil floating on the top of the water. There are two general types of separators - the American Petroleum Institute (API) separators and coalescing plate (CP) separators. Both use gravity to remove floating and dispersed oil. API separators, or baffle separators, are generally composed of three chambers separated by baffles. The efficiency of these separators is dependent on detention time in the center, or detention chamber, and on droplet size. CP separators use a series of parallel

plates, which improve separation efficiency by providing more surface area, thus reducing the space needed for the separator. Oil/water separators must be located off-line from the primary conveyance/detention system, bypassing flows greater than the water quality design flow. Other devices/facilities that may be used for removal of oil include catch basin inserts and linear sand filters. Oil control devices/facilities should always be placed upstream of other treatment facilities and as close to the source of oil generation as possible.

- **Pretreatment.** Presettling basins are often used to remove sediment from runoff prior to discharge into other treatment facilities. Basic treatment facilities, listed in Step 4 – Figure 2.1, can also be used to provide pretreatment. Pretreatment often must be provided for filtration and infiltration facilities to protect them from clogging or to protect groundwater. Appropriate pretreatment devices include a pre-settling basin, wet pond/vault, biofilter, constructed wetland, or oil/water separator.
- **Infiltration.** Infiltration refers to the use of the filtration, adsorption, and biological decomposition properties of native, in-situ soils to remove pollutants. Infiltration can provide multiple benefits including pollutant removal, peak flow control, groundwater recharge, and flood control. However, one condition that can limit the use of infiltration is the potential adverse impact on groundwater quality (See Chapter 2 of Volume I for geographic specific requirements). To adequately address the protection of groundwater when evaluating infiltration it is important to understand the difference between soils that are suitable for runoff treatment and soils only suitable for flow control. Sufficient organic content and sorption capacity to remove pollutants must be present for in-situ soils to provide runoff treatment. Examples are silty and sandy loams. Coarser soils, such as gravelly sands, can provide flow control but are not suitable for providing runoff treatment. The use of coarser in-situ soils to provide flow control for runoff from pollutant generating surfaces must always be preceded by treatment to protect groundwater quality. Thus, there will be instances when in-situ soils are suitable for treatment but not flow control, and vice versa.
- **Filtration.** A relatively new application of a pollutant removal system for storm water is the use of various media such as sand, perlite, zeolite, and carbon, to remove low levels of total suspended solids (TSS). Specific media such as activated carbon or zeolite, can remove hydrocarbons and soluble metals. Filter systems can be configured as basins, trenches, or cartridges.
- **“Emerging Technologies.”** Emerging technologies are new technologies that have not been evaluated using approved protocols, but for which preliminary data indicate that they may provide a desirable level of storm water pollutant removal. They have not been evaluated in sufficient detail to be acceptable as stand alone BMPs for general usage in new development or redevelopment situations requiring Basic Treatment. In the instances noted in Chapter 3, a few

emerging technologies are allowed to help remove metals, hydrocarbons, and nutrients. Otherwise, their use is restricted in accordance with their level of development as explained in Chapter 12. The recommendations for use of these emerging technologies will change as we collect more data on their performance. Updated recommendations on their use will be posted to the Ecology website. Meanwhile, emerging technologies can also be used for retrofit situations.

- **“On-line” Systems.** Most treatment facilities can be designed as “On-line” systems with flows above the water quality design flow or volume simply passing through the facility with lesser or no pollutant removal efficiency. However, it is sometimes desirable to restrict flows to treatment facilities and bypass the remaining higher flows around them. These are called “Off-line” systems. An example of an on-line system is a wetpool that maintains a permanent pool of water for runoff treatment purposes.
- **Design Flow.** For information on determining the design storm and flows for sizing treatment facilities refer to Chapter 4 of this volume.

# Chapter 2 – Treatment Facility Selection Process

---

This chapter describes a step-by-step process for selecting the type of treatment facilities that will apply to individual projects. Physical features of sites that are applicable to treatment facility selection are also discussed. Refer to Chapter 3 for additional detail on the four treatment menus - oil control treatment, phosphorous treatment, enhanced treatment, and basic treatment.

## 2.1 Step-by-Step Selection Process for Treatment Facilities

Please refer to Figure 2.1. Use the step-by-step process outlined below to determine the type of treatment facilities applicable to the project.

### Step 1: Determine the Receiving Waters and Pollutants of Concern Based on Offsite Analysis

To obtain a more complete determination of the potential impacts of a storm water discharge, the City requires an offsite analysis under the conditions described in Chapter 2, Section 2.5 and Chapter 3, Section 3.5.7 of Volume I. Even without an offsite analysis requirement, the project proponent must determine the natural receiving water for the storm water drainage from the project site (groundwater, wetland, lake, stream, or salt water). This is necessary to determine the applicable treatment menu from which to select treatment facilities. If the discharge is to the City of Tacoma's municipal storm drainage system, the receiving water for the drainage system must be determined by the applicant. Please see Chapter 2 of Volume I.

The applicant should verify whether any type of water quality management plan, basin plan, water cleanup plan, and/or local ordinances or regulations have established specific requirements for the receiving waters. Please see Chapter 2 of Volume I. Examples of plans to be aware of include:

- **Watershed or Basin Plans:** These can be developed to cover a wide variety of geographic scales (e.g., Water Resource Inventory Areas, or sub-basins of a few square miles). They can be focused solely on establishing storm water requirements (e.g., "Stormwater Basin Plans"), or can address a number of pollution and water quantity issues, including urban storm water (e.g., Puget Sound Non-Point Action Plans).
- **Water Clean-Up Plans:** These plans are written to establish a Total Maximum Daily Load (TMDL) of a pollutant or pollutants in a specific receiving water or basin, and to identify actions necessary to remain below that maximum loading. The plans may identify discharge limitations or management limitations (e.g., use of specific treatment facilities) for storm water discharges from new and redevelopment projects.

- **Groundwater Management Plans** (Wellhead Protection Plans): To protect groundwater quality and/or quantity, these plans may identify actions required of storm water discharges. Please see Chapter 2 of Volume I.
- **Lake Management Plans:** These plans are developed to protect lakes from eutrophication due to inputs of phosphorus from the drainage basin. Control of phosphorus from new development is a likely requirement in any such plans.

An analysis of the proposed land use(s) of the project should also be used to determine the storm water pollutants of concern. Table 2.1 lists the pollutants of concern from various land uses. Refer to this table for examples of treatment options after determining whether “basic,” “enhanced,” or “phosphorus” treatment requirements apply to the project. Those decisions are made in the steps below.

### **Step 2: Determine if an Oil Control Facility/Device is Required**

The use of oil control devices and facilities is dependent upon the specific land use proposed for development.

The Oil Control Menu (Chapter 3, Section 3.2) applies to projects that have “high-use sites.” High-use sites are those that typically generate high concentrations of oil due to high traffic turnover or the frequent transfer of oil. High-use sites include:

- An area of a commercial or industrial site subject to an expected average daily traffic (ADT) count equal to or greater than 100 vehicles per 1,000 square feet of gross building area;
- An area of a commercial or industrial site subject to petroleum storage and transfer in excess of 1,500 gallons per year, not including routinely delivered heating oil;
- An area of a commercial or industrial site subject to parking, storage or maintenance of 25 or more vehicles that are over 10 tons gross weight (trucks, buses, trains, heavy equipment, etc.);
- A road intersection with a measured average daily traffic (ADT) count of 25,000 vehicles or more on the main roadway and 15,000 vehicles or more on any intersecting roadway, excluding projects proposing primarily pedestrian or bicycle use improvements.

*Note: The traffic count can be estimated using information from “Trip Generation,” published by the Institute of Transportation Engineers, or from a traffic study prepared by a professional engineer or transportation specialist with experience in traffic estimation.*

Please refer to the Oil Control Menu for a listing of oil control facility options. Then see Chapter 11 of this volume for guidance on the proper selection of options and design details.

*Note: Some land use types require the use of a spill control (SC-type) oil/water separator. Those situations are described in Volume IV and are separate from this oil control facility/device requirement. While a number of activities may be required to use spill control (SC-type) separators, only a few will necessitate an American Petroleum Institute (API) or a coalescing plate (CP)-type separators for treatment. The following urban land uses are likely to have areas that fall within the definition of “high-use sites” or have sufficient quantities of free oil present that can be treated by an API or CP-type oil/water separator:*

- Industrial Machinery and Equipment, and Railroad Equipment Maintenance
- Log Storage and Sorting Yards
- Aircraft Maintenance Areas
- Railroad Yards
- Fueling Stations
- Facilities with drive-thru windows (e.g. espresso stands, fast food restaurants, banks...etc.)
- Vehicle Maintenance and Repair
- Construction Businesses (paving, heavy equipment storage and maintenance, storage of petroleum products)

If oil control is required for the site, please refer to the General Requirements in Chapter 4. These requirements may affect the design and placement of facilities on the site (e.g., flow splitting).

***If an Oil Control Facility is required, select and apply an Oil Control Facility. Please refer to the Oil Control Menu in Chapter 3, Section 3.2. After selecting an Oil Control Facility, proceed to Step 3.***

***If an Oil Control Facility is not required, proceed directly to Step 3.***

### **Step 3: Determine if Control of Phosphorous is Required**

Please refer to the plans, ordinances, and regulations identified in Step 1 as sources of information.

The requirement to provide phosphorous control is determined by the City, Department of Ecology, or USEPA. The City will use the following sources of information for pursuing plans and implementing ordinances and/or regulations:

- Those waterbodies reported under section 305(b) of the Clean Water Act, and designated as not supporting beneficial uses due to phosphorous;
- Those listed in Washington State's Nonpoint Source Assessment required under section 319(a) of the Clean Water Act due to nutrients.

If phosphorus control is required, select and apply a phosphorous treatment facility. Please refer to the Phosphorus Treatment Menu in Chapter 3, Section 3.3. Select an option from the menu after reviewing the applicability and limitations, site suitability, and design criteria of each for compatibility with the site. You may also use Tables 2.1 through 2.3 as an initial screening of options.

If you have selected a phosphorus treatment facility, please refer to the General Requirements in Chapter 4. They may affect the design and placement of the facility on the site.

*Note: Project sites subject to the Phosphorus Treatment requirement could also be subject to the Enhanced Treatment requirement (see Step 4). In that event, apply a facility or a treatment train that is listed in both the Enhanced Treatment Menu and the Phosphorus Treatment Menu.*

**If phosphorus treatment is not required for the site, proceed to Step 4.**

#### **Step 4: Determine if Enhanced Treatment is Required**

In addition to basic treatment, enhanced treatment is required for:

Industrial project sites,  
Commercial project sites,  
Multi-family project sites, and  
Arterials and highways

that discharge to fish-bearing streams, lakes, or to waters or conveyance systems tributary to fish-bearing streams or lakes. For developments with a mix of land use types, the Enhanced Treatment requirement shall apply when the runoff from the areas subject to the Enhanced Treatment requirement comprise 50% or more of the total runoff within a threshold discharge area.

**If the project must apply Enhanced Treatment, select and apply an appropriate Enhanced Treatment facility.** Please refer to the Enhanced Treatment Menu in Chapter 3, Section 3.4. Select an option from the menu after reviewing the applicability and limitations, site suitability, and design criteria of each for compatibility with the site. You may also use Tables 2.1 through 2.3 for an initial screening of options.

*Note: Project sites subject to the Enhanced Treatment requirement could also be subject to a phosphorus removal requirement if located in an area designated for phosphorus control. In that event, apply a facility or a treatment train that is listed in both the Enhanced Treatment Menu and the Phosphorus Treatment Menu.*

If you have selected an Enhanced Treatment facility, please refer to the General Requirements in Chapter 4. They may affect the design and placement of the facility on the site.

***Infiltration for Pollutant Removal as an enhanced treatment practice:***

Where appropriate, the applicant shall determine if infiltration for pollutant removal is practicable.

Please check the infiltration treatment design criteria in Chapter 7. Infiltration can be effective at treating stormwater runoff, but soil properties must be appropriate to achieve effective treatment while not adversely impacting ground water resources. The location and depth to bedrock, the water table, or impermeable layers (such as glacial till), and the proximity to wells, foundations, septic tank drainfields, and unstable slopes can preclude the use of infiltration. Infiltration treatment facilities must be preceded by a pretreatment facility such as a presettling basin or vault, to reduce the occurrence of plugging. Any of the basic treatment facilities, and detention ponds designed to meet flow control requirements, can also be used for pre-treatment.

If infiltration is planned, please refer to the General Requirements in Chapter 4. They can affect the design and placement of facilities on your site. For non-residential developments, if the infiltration site is within  $\frac{1}{4}$  mile of a fish-bearing stream, a tributary to a fish-bearing stream, or a lake, please refer to the Enhanced Treatment Menu (Section 3.4). Read the "Where Applied" paragraph in that section to determine if the Enhanced Treatment Menu applies to part of the site or the entire site. If it applies, read the "Note" under "Infiltration with appropriate pretreatment" to identify special pretreatment needs. If the infiltration site is within  $\frac{1}{4}$  mile of phosphorus-sensitive receiving water, please refer to the Phosphorus Treatment Menu (Section 3.3) for special pretreatment needs.

*Note: Infiltration through soils that do not meet the site suitability criteria in Chapter 7 is allowable as a flow control BMP (see Chapter 3 of Volume III). However, the infiltration must be preceded by at least a basic treatment facility. Following a basic treatment facility (or an enhanced treatment or phosphorus treatment facility in accordance with the previous paragraph) infiltration through the bottom of a detention/retention facility for flow control can also be acceptable as a way to reduce direct discharge volumes to streams and to reduce the size of the facility.*

**If Enhanced Treatment is required for the site, and infiltration is practicable, select and apply pretreatment and an infiltration facility. If infiltration is not practicable, use other Enhanced Treatment Practices.**

**If Enhanced Treatment does not apply to the site, please proceed to Step 5.**



## **Step 5: Select a Basic Treatment Facility**

Please refer to the Basic Treatment Menu in Section 3.5. Select an option from the menu after reviewing the applicability and limitations, site suitability, and design criteria of each for compatibility with the site. You may also use Tables 2.1 through 2.3 in this chapter as an initial screening of options.

After selecting a Basic Treatment Facility, please refer to the General Requirements in Chapter 4. They may affect the design and placement of the facility on the site.

**Note: For guidance on additional factors that can affect treatment facility selection, please refer to Section 2.2.**

The Basic Treatment Menu is generally applied to:

- Residential projects not otherwise needing phosphorus control in Step 3 as designated by USEPA, Department of Ecology, or the City;
- Project sites discharging directly to salt waters, river segments, and lakes listed in Appendix I-C;
- Project sites that drain to streams that are not fish-bearing, or to waters not tributary to fish-bearing streams;
- Landscaped areas of industrial, commercial, and multi-family project sites, and parking lots of industrial and commercial project sites, dedicated solely to parking of employees' private vehicles, that do not involve any other pollution-generating sources (e.g., industrial activities, customer parking, storage of erodible or leachable material, wastes or chemicals);
- For developments with a mix of land use types, the Basic Treatment requirement shall apply when the runoff from the areas subject to the Basic Treatment requirement comprise 50% or more of the total runoff within a threshold discharge area.
- Project sites that discharge to the ground, UNLESS:
  - The soil suitability criteria for infiltration treatment are met (use infiltration treatment; see Chapter 7 of this volume), or
  - The project uses infiltration strictly for flow control – not treatment - and the discharge is within ¼-mile of a phosphorus sensitive lake (use the Phosphorus Treatment Menu), or within ¼ mile of a fish-bearing stream, or a lake (use the Enhanced Treatment Menu).

***You have completed the treatment facility selection process.***

## **2.2 Other Treatment Facility Selection Factors**

The selection of a treatment facility should be based on site physical factors and pollutants of concern. The requirements for use of Enhanced Treatment or Phosphorus Treatment represent facility selection based on pollutants of concern. Even if the site is not subject to those requirements, try to choose a facility that is more likely to do a better job

removing the types of pollutants generated on the site. The types of site physical factors that influence facility selection are summarized below.

### **Pollutants of Concern (Table 2.1 and Table 2.2)**

Table 2.1 summarizes the pollutants of concern and those land uses that are likely to generate pollutants. It also provides suggested basic and enhanced treatment options for each land use. For example, oil and grease are the expected pollutants from an uncovered fueling station. Using Table 2.1, a combination of an oil/water separator and a biofilter could be considered as the basic treatment for runoff from uncovered fueling stations. Table 2.2 is a general listing of the relative effectiveness of classes of treatment facilities in removing key storm water pollutants.

### **Soil Type (Table 2.3)**

The permeability of the soil underlying a treatment facility has a profound influence on its effectiveness. This is particularly true for infiltration treatment facilities that are best sited in sandy to loamy sand soils. They are not generally appropriate for sites that have final infiltration rates (f) of less than 0.5 inches per hour. Wet pond facilities situated on coarser soils will need a synthetic liner or the soils amended to reduce the infiltration rate and provide treatment. Maintaining a permanent pool in the first cell is necessary to avoid resuspension of settled solids. Biofiltration swales in coarse soils can also be amended to reduce the infiltration rate.

### **High Sediment Input**

High TSS loads can clog infiltration soil, sand filters, and coalescing plate oil & water separators. Pretreatment with a presettling basin, wet vault, or another basic treatment facility would typically be necessary.

### **Other Physical Factors**

*Slope:* Steep slopes restrict the use of several BMPs. For example, biofiltration swales are usually situated on sites with slopes of less than 6%, although greater slopes can be considered. Infiltration BMPs are not suitable when the slope exceeds 15%. Please see Section 4.3.

*High Water Table:* Unless there is sufficient horizontal hydraulic receptor capacity the water table acts as an effective barrier to exfiltration and can sharply reduce the efficiency of an infiltration system. If the high water table extends to within five (5) feet of the bottom of an infiltration BMP, the site is seldom suitable.

*Depth to Bedrock/Hardpan/Till:* The downward exfiltration of storm water is also impeded if a bedrock or till layer lies too close to the surface. If the impervious layer lies within five feet below the bottom of the infiltration BMP the site is not suitable. Similarly, pond BMPs are often not feasible if bedrock lies within the area that must be excavated.

*Proximity to Foundations and Wells:* Since infiltration BMPs convey runoff back into the soil, some sites may experience problems with local

seepage. This can be a real problem if the BMP is located too close to a building foundation. Please see Section 4.3. Another risk is groundwater pollution, hence the requirement to site infiltration systems more than 100 feet away from drinking water wells (see Section 4.3 of this volume and Chapter 2 of Volume I).

*Maximum Depth:* Wet ponds are also subject to a maximum depth limit for the "permanent pool" volume. Deep ponds (greater than 8 feet) may stratify during summer and create low oxygen conditions near the bottom resulting in re-release of phosphorus and other pollutants back into the water.

<b>Table 2.1 Suggested Storm Water Treatment Options for New Development and Redevelopment Projects</b>				
<b>Pollutant Sources</b>	<b>Pollutants of Concern</b>	<b>Basic Treatment</b>	<b>Enhanced Treatment</b>	<b>Phosphorus Treatment<sup>1</sup></b>
<b>ROOFS:</b>				
Com/Ind				
Metal	Zn	STW/INF	LSF/ASF/STW/INF	
Vents & Emissions <sup>(2)</sup>	O & G, TSS, Organics	OWS/CBI + BF/WP/STW	OWS/CBI + INF/ASF/STW/LSF	OWS/CBI + INF/LWP/LSF
<b>PARKING LOT/DRIVEWAY:</b>				
>High-use Site	High O & G, TSS, Cu, Zn, PAH	OWS/CBI/LinSF + BF/WP/STW	OWS/CBI + BF/WP/WV + SF	OWS/CBI + LSF/LWP, or OWS/CBI + BF/WP/WV + SF
<High-use	O & G, TSS	BF/WP/STW	BF/WP/STW/WV + SF	LSF/LWP, or BF/WP/WV+SF
<b>STREETS/HIGHWAYS:</b>				
Arterials/H'ways	O & G, TSS, Cu, Zn, PAH	BF/WP/WV/STW	INF/LSF/ASF/STW, or BF/WV/WP + SF	INF/LSF/LWP, or BF/WV + SF
Residential Collectors	Low O & G, TSS, Cu, Zn	BF/WP/STW/INF	Not Applicable	INF/LSF/LWP, or BF/WV + SF
High Use Site Intersections	High O & G, TSS, Cu, Zn, PAH	OWS + BF/WP/WV/LinSF	OWS + BF/WV+SF, or OWS + LinSF+BF	OWS + ASF, or OWS + LinSF + Filter Strip
<b>OTHER SOURCES:</b>				
Industrial/Commercial Development	O & G, TSS, Cu, Zn	WP/WV/SF/STW	LSF/ASF/STW, or BF/WP/WV + SF	LSF/ASF/LWP, or BF/WP/STW + SF
Residential Development	TSS, Pest/Herbicides Nutrients	INF/BF/WP/SF/STW	Not Applicable	INF/LSF/LWP, or BF/WP/STW + SF
Large PGPS	TSS, Nutrients, Pest/Herbicides	WP/STW/SF	Not Applicable	LSF/LWP, or WP/STW + SF
Uncovered Fueling Stations:	High conc. O & G	OWS + BF/WP	OWS + LSF/ASF, or OWS+LinSF+Filter strip	OWS + LSF/ASF, or OWS+LinSF+ Filter strip
Industrial Yards	High O & G, TSS, Metals, PAH	OWS/CBI + BF/WP, or PSB/WV + OWS/CBI + BF/WP	OWS/CBI + LSF/ASF/STW, or OWS/CBI + BF/WP/WV + SF	OWS/CBI + LSF/ASF/LWP, or OWS/CBI + BF/WP/STW + SF
	Metals, TSS, PAH	BF/WP/STW, or PSB +BF/WP/STW	LSF/ASF/STW, or BF/WP/WV + SF	LSF/ASF/LWP, or BF/WP/STW + SF

**Notes:**

- 1 Though phosphorus is not typically listed as a pollutant of concern, it is present in most urban runoff situations. It becomes a pollutant of concern when identified by USEPA, the Department of Ecology, or a local government in a local management plan and when requirements are established in local ordinance or rules. If phosphorus is identified as a pollutant of concern, consider the treatment options listed here.
- 2 Application of effective source control measures is the preferred approach for pollutant reduction. Where source control measures are not used, or where they are ineffective, storm water treatment is necessary.

**Legend:**

ASF = Amended Sand Filter  
 BF = Biofilter (includes swales and strips)

Cu = Copper  
 LSF = Large Sand Filter  
 LWP = Large Wet Pond  
 OWS = Oil & Water Separator  
 PSB = Presettling Basin  
 SF = Sand Filter  
 TSS = Total Suspended Solids  
 WV = Wetvault

INF = Infiltration  
 CBI = Catch Basin Insert, if applicable (See Chapter 10)  
 Com/Ind = Commercial or industrial  
 LinSF = Linear Sand Filter  
 O & G = Oil and Grease  
 PAH = Polycyclic Aromatic Hydrocarbons  
 PGPS = Pollution-generating pervious surface  
 STW = Storm Water Treatment Wetland  
 WP = Wet Pond  
 Zn = Zinc

/ = or : The slashes between the abbreviations for treatment types are intended to indicate equivalent treatment options

**Additional Notes:**

If a detention facility is needed for flow control to meet Min. Requirement #7 or #8, a combined detention and Wetpool (Basic or Large depending upon the discharge circumstance) facility should be considered.

<b>Table 2.2 Ability of Treatment Facilities to Remove Key Pollutants<sup>(1) (3)</sup></b>						
	<b>TSS</b>	<b>Dissolved Metals</b>	<b>Soap</b>	<b>Total Phosphorus</b>	<b>Pesticides/ Fungicides</b>	<b>Hydro-carbons</b>
Wet Pond	Ω	+		+		+
Wet Vault	Ω					
Biofiltration	Ω	+			+	+
Sand Filter	Ω	+		+		+
Constructed Wetland	Ω	Ω	Ω		Ω	Ω
Compost Filters	Ω	+			Ω	Ω
Infiltration <sup>(2)</sup>	Ω				+	+
Oil/Water Separator						Ω

Footnotes:  
 Ω Major Process  
 : Minor Process  
 (1) Adapted from Kulzer, King Co.  
 (2) Assumes Loamy sand, Sandy loam, or Loam soils  
 (3) If neither a Major or Minor Process is shown, the Treatment Facility is not particularly effective at treating the identified pollutant

<b>Table 2.3 Screening Treatment Facilities Based on Soil Type</b>			
<b>Soil Type</b>	<b>Infiltration</b>	<b>Wet Pond*</b>	<b>Biofiltration* (Swale or Filter Strip)</b>
Coarse Sand or Cobbles	6	6	6
Sand	4	6	6
Loamy Sand	4	6	4
Sandy Loam	4	6	4
Loam	6	6	4
Silt Loam	6	6	4
Sandy Clay Loam	6	4	4
Silty Clay Loam	6	4	4
Sandy Clay	6	4	4
Silty Clay	6	4	6
Clay	6	4	6

Notes:

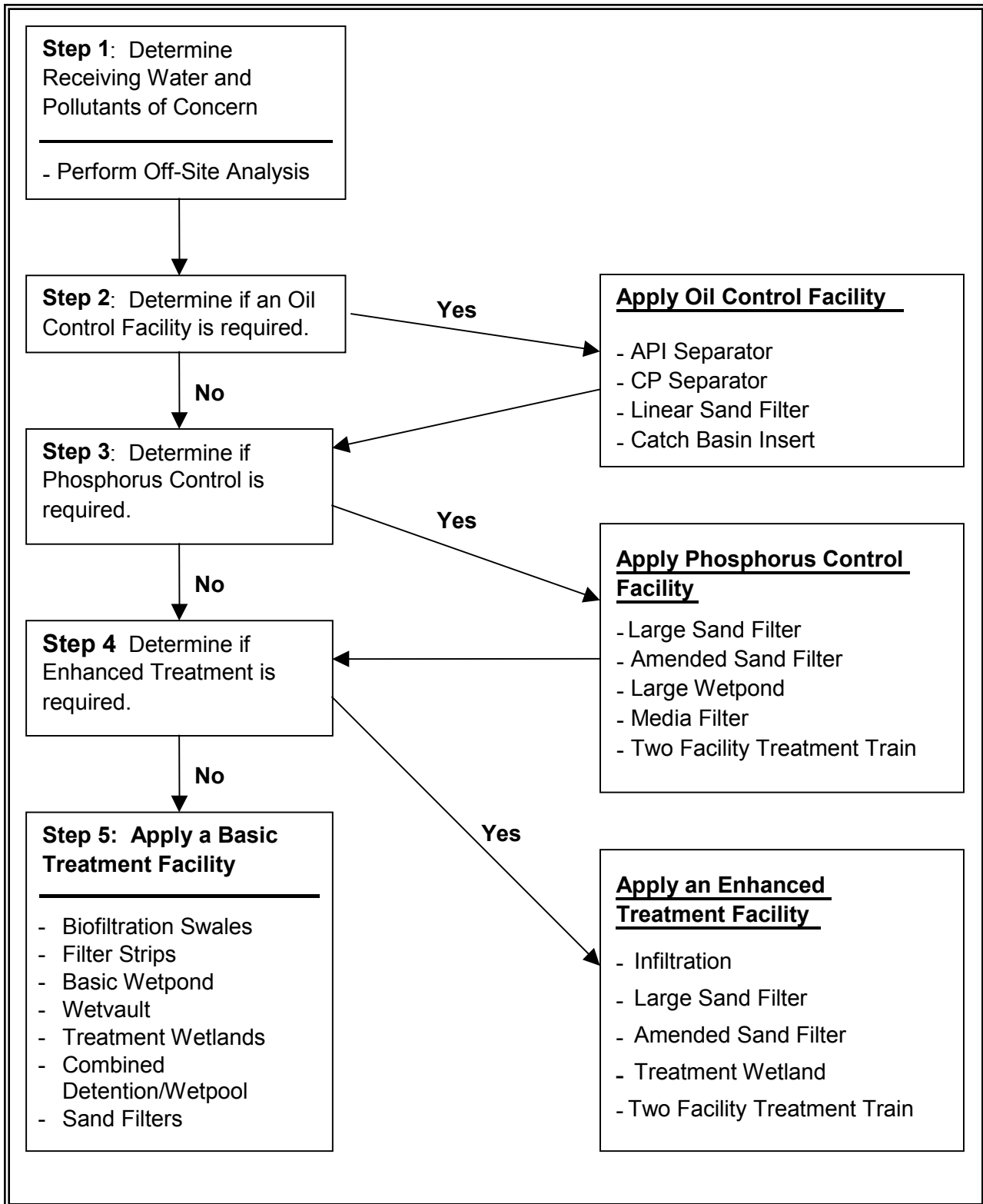
4 Indicates that use of the technology is generally appropriate for this soil type.

6 Indicates that use of the technology is generally not appropriate for this soil type

\* Coarser soils may be used for these facilities if a liner is installed to prevent infiltration, or if the soils are amended to reduce the infiltration rate.

Note: Sand filtration is not listed because its feasibility is not dependent on soil type.

**Figure 2.1 Treatment Facility Selection Flow Chart**



# Chapter 3 - Treatment Facility Menus

---

This chapter identifies choices that comprise the treatment facility menus referred to in Chapter 2. The menus in this chapter are discussed in the order of the decision process shown in Figure 2.1 and are as follows:

**Oil Control Menu**, Section 3.2

**Phosphorus Treatment Menu**, Section 3.3

**Enhanced Treatment Menu**, Section 3.4

**Basic Treatment Menu**, Section 3.5

## 3.1 Guide to Applying Menus

**Read the step-by-step selection process for treatment facilities in Chapter 2.**

Determine which menus apply to the discharge situation. This will require knowledge of: (1) the receiving water(s) that the project site ultimately discharges to; (2) whether the City, the Department of Ecology, or the USEPA has identified the receiving water as subject to phosphorus or other targeted pollutant control requirements (see Volume I, Chapter 2); and (3) whether the site qualifies as subject to oil control.

**Determine if your project requires oil control.**

If the project requires oil control, or if you elect to provide enhanced oil pollution control, choose one of the options presented in the Oil Control Menu, Section 3.2. Detailed designs for oil control facilities are given in subsequent chapters.

**Note:** One of the other three treatment menus will also need to be applied along with oil control.

**Find the Treatment Menu that applies to the project – Basic, Enhanced, or Phosphorus.**

Each menu presents treatment options. Select one option. Since all options are intended to provide equivalent removal of the target pollutant, the choice will depend only on the constraints and opportunities of the site. A project site may be subject to both the Enhanced Treatment requirement and the Phosphorus Treatment requirement. In that event, select a facility or a treatment train that is listed in both treatment menus. Detailed facility designs for all the possible options are given in subsequent chapters in this Volume.

**Read Chapter 4 concerning general facility requirements.**

They apply to all facilities and may affect the design and placement of facilities on the site.

## 3.2 Oil Control Menu

**Note:** Where this menu is applicable, it is in addition to facilities required by one of the other Treatment Menus.

**Where Applied:** The Oil Control Menu applies to projects that have **high-use sites**. **High-use sites** are those that typically generate high concentrations of oil due to high traffic turnover or the frequent transfer of oil. **High-use sites** include:

- An area of a commercial or industrial site subject to an expected average daily traffic (ADT) count equal to or greater than 100 vehicles per 1,000 square feet of gross building area;
- An area of a commercial or industrial site subject to petroleum storage and transfer in excess of 1,500 gallons per year, not including routinely delivered heating oil;
- An area of a commercial or industrial site subject to parking, storage or maintenance of 25 or more vehicles that are over 10 tons gross weight (trucks, buses, trains, heavy equipment, etc.);
- A road intersection with a measured ADT count of 25,000 vehicles or more on the main roadway and 15,000 vehicles or more on any intersecting roadway, excluding projects proposing primarily pedestrian or bicycle use improvements.

**Note:** The traffic count can be estimated using information from “Trip Generation” published by the Institute of Transportation Engineers, or from a traffic study prepared by a professional engineer or transportation specialist with experience in traffic estimation.

Oil control facilities from this menu should be used on other sites that generate high concentrations of oil. In general, all-day parking areas are not intended to be defined as **high-use sites**, and should not require the oil control options listed in this menu. Gasoline stations, with or without small food stores, will likely exceed the high-use site threshold. The petroleum storage and transfer criterion is intended to address regular transfer operations such as gasoline service stations, not occasional filling of heating oil tanks.

**Application on the Project Site:** Oil control facilities are to be placed upstream of other facilities, as close to the source of oil generation as practical. For high-use sites located within a larger commercial center, only the impervious surface associated with the high-use portion of the site is subject to treatment requirements. If common parking for multiple businesses is provided, treatment shall be applied to the number of parking stalls required for the high-use business only. However, if the treatment collection area also receives runoff from other areas, the treatment facility must be sized to treat all water passing through it.



High-use roadway intersections shall treat lanes where vehicles accumulate during the signal cycle, including left and right turn lanes and through lanes, from the beginning of the left turn pocket. If no left turn pocket exists, the treatable area shall begin at a distance equal to three car lengths from the stop line. If runoff from the intersection drains to more than two collection areas that do not combine within the intersection, treatment may be limited to any two of the collection areas.

**Performance Goal:** The facility choices in the Oil Control Menu are intended to achieve the goals of no ongoing or recurring visible sheen, and to have a 24-hour average Total Petroleum Hydrocarbon (TPH) concentration no greater than 10 mg/l, and a maximum of 15 mg/l for a discrete sample (grab sample).

**Note:** Use the method for NWTPH-Dx in Ecology Publication No. ECY 97-602, Analytical Methods for Petroleum Hydrocarbons. If the concentration of gasoline is of interest, the method for NWTPH-Gx should be used to analyze grab samples.

**Options:** Oil control options include facilities that are small, treat runoff from a limited area, and require frequent maintenance. The options also include facilities that treat runoff from larger areas and generally have less frequent maintenance needs.

- **API-Type Oil/Water Separator** – See Chapter 11
- **Coalescing Plate Oil/Water Separator** – See Chapter 11
- **Catch Basin Inserts** – See Chapter 12
- **Linear Sand Filter** – See Chapter 8

**Note:** The linear sand filter is used in the Basic, Enhanced, and Phosphorus Treatment menus also. If used to satisfy one of those treatment requirements, the same facility shall not also be used to satisfy the oil control requirement unless enhanced maintenance is assured. This is to prevent clogging of the filter by oil so that it will function for suspended solids and phosphorus removal as well. Quarterly cleaning is required unless specified otherwise by the designer.

### 3.3 Phosphorus Treatment Menu

**Where Applied:** The Phosphorus Treatment Menu applies to projects within watersheds that have been determined by the City, the Department of Ecology, or the USEPA to be sensitive to phosphorus and that are being managed to control phosphorus inputs from storm water. This menu applies to storm water conveyed to the phosphorous-sensitive water body (lake) by surface flow as well as to storm water infiltrated within one-quarter mile of the lake in soils that do not meet the soil suitability criteria in Chapter 7.

**Performance Goal:** The Phosphorus Menu facility choices are intended to achieve a goal of 50% total phosphorus removal for a range of influent concentrations of 0.1 – 0.5 mg/l total phosphorus. In addition, the choices

are intended to achieve the Basic Treatment performance goal. The performance goal applies to the water quality design storm volume or flow rate, whichever is applicable, and on an annual average basis. The incremental portion of runoff in excess of the water quality design flow rate or volume can be routed around the facility (off-line treatment facilities), or can be passed through the facility (on-line treatment facilities) provided a net pollutant reduction is maintained.

**Options:** Any one of the following options may be chosen to satisfy the phosphorus treatment requirement.

- **Infiltration with appropriate pretreatment** – See Chapter 6 and Chapter 7
  - *Infiltration Treatment* - If infiltration is through soils meeting the minimum site suitability criteria for infiltration treatment (see Chapter 7), a presettling basin or a basic treatment facility can serve for pretreatment.
  - *Infiltration Preceded by Basic Treatment* - If infiltration is through soils that do not meet the soil suitability criteria for infiltration treatment, treatment must be provided by a basic treatment facility unless the soil and site fit the description in the next option below.
  - *Infiltration Preceded by Phosphorus Treatment* - If the soils do not meet the soil suitability criteria **and** the infiltration site is within ¼ mile of a phosphorus-sensitive receiving water, or a tributary to that water, treatment must be provided by one of the other treatment facility options listed below.
- **Large Sand Filter** – See Chapter 8
- **Amended Sand Filter** – See Chapter 12
- **Large Wetpond** – See Chapter 10
- **Media Filter targeted for phosphorus removal** – See Chapter 12
  - Note:** The use of a Stormfilter™ with iron-infused media is approved for use in limited circumstances, provided a monitoring program consistent with adopted protocols is implemented.
- **Two-Facility Treatment Trains** – See Table 3.1

### 3.4 Enhanced Treatment Menu

**Where Applied:** Enhanced treatment is required for:

- Industrial project sites,
- Commercial project sites,
- Multi-family project sites, and
- Arterials and highways

that discharge to fish-bearing streams, lakes, or to waters or conveyance systems tributary to fish-bearing streams or lakes. Areas of multi-family,

industrial and commercial project sites that are identified as subject to Basic Treatment requirements are not subject to Enhanced Treatment requirements. For developments with a mix of land use types, the Enhanced Treatment requirement shall apply when the runoff from the areas subject to the Enhanced Treatment requirement comprise 50% or more of the total runoff within a threshold discharge area.

**Performance Goal:** The Enhanced Menu facility choices are intended to provide a higher rate of removal of dissolved metals than Basic Treatment facilities. Due to the sparse data available concerning dissolved metals removal in storm water treatment facilities, a specific numeric removal efficiency goal was not established at the time of publication of Ecology's Western Washington Manual. The performance goal assumes that the facility is treating storm water with dissolved Copper typically ranging from 0.003 to 0.02 mg/l, and dissolved Zinc ranging from 0.02 to 0.3 mg/l, and 80% removal of TSS (the Basic Treatment performance goal).

The performance goal applies to the water quality design storm volume or flow rate, whichever is applicable, and on an annual average basis. The incremental portion of runoff in excess of the water quality design flow rate or volume can be routed around the facility (off-line treatment facilities), or can be passed through the facility (on-line treatment facilities) provided a net pollutant reduction is maintained.

**Options:** Any one of the following options may be chosen to satisfy the enhanced treatment requirement:

- **Infiltration with appropriate pretreatment** – See Chapter 7
  - *Infiltration Treatment* - If infiltration is through soils meeting the minimum site suitability criteria for infiltration treatment (see Chapter 7), a presettling basin or a basic treatment facility can serve for pretreatment.
  - *Infiltration Preceded by Basic Treatment* - If infiltration is through soils that do not meet the soil suitability criteria for infiltration treatment, treatment must be provided by a basic treatment facility unless the soil and site fit the description in the next option below.
  - *Infiltration Preceded by Enhanced Treatment* - If the soils do not meet the soil suitability criteria **and** the infiltration site is within ¼ mile of a fish-bearing stream, a tributary to a fish-bearing stream, or a lake, treatment must be provided by one of the other treatment facility options listed below.
- **Large Sand Filter** – See Chapter 8
- **Amended Sand Filter** – See Chapter 12
- **Stormwater Treatment Wetland** – See Chapter 10
- **Two Facility Treatment Trains** – See Table 3.2

### 3.5 Basic Treatment Menu

**Where Applied:** The Basic Treatment Menu is generally applied to:

- Project sites that discharge to the ground, **unless**:
  - The soil suitability criteria for infiltration treatment are met (see Chapter 7), or
  - The project uses infiltration strictly for flow control – not treatment – and the discharge is within ¼-mile of a phosphorus-sensitive water body (lake) (use the Phosphorus Treatment Menu), or within ¼ mile of a fish-bearing stream or a lake (use the Enhanced Treatment Menu).
- Residential projects not otherwise needing phosphorus control in Step 3 (see Chapter 2) as designated by USEPA, the Department of Ecology, or the City; and
- Project sites discharging directly to salt waters, river segments, and lakes listed in Appendix I-C; and
- Project sites that drain to streams that are not fish-bearing, or to waters not tributary to fish-bearing streams;
- Landscaped areas of industrial, commercial, and multi-family project sites, and parking lots of industrial and commercial project sites, dedicated solely to parking of employees' private vehicles, that do not involve any other pollution-generating sources (e.g., industrial activities, customer parking, storage of erodible or leachable material, wastes or chemicals).

For developments with a mix of land use types, the Basic Treatment requirement shall apply when the runoff from the areas subject to the Basic Treatment requirement comprise 50% or more of the total runoff within a threshold discharge area.

**Performance Goal:** The Basic Treatment Menu facility choices are intended to achieve 80% removal of total suspended solids for influent concentrations that are greater than 100 mg/l, but less than 200 mg/l. For influent concentrations greater than 200 mg/l, a higher treatment goal may be appropriate. For influent concentrations less than 100 mg/l, the facilities are intended to achieve an effluent goal of 20 mg/l total suspended solids.

The performance goal applies to the water quality design storm volume or flow rate, whichever is applicable. The goal also applies on an average annual basis to the entire annual discharge volume (treated plus bypassed). The incremental portion of runoff in excess of the water quality design flow rate or volume can be routed around the facility (off-line treatment facilities), or can be passed through the facility (on-line treatment facilities) provided a net TSS reduction is maintained.

The performance goal assumes that the facility is treating storm water with a typical particle size distribution. For a description of a typical particle size distribution, please refer to the storm water monitoring protocol on the Department of Ecology website.

**Options:** Any one of the following options may be chosen to satisfy the basic treatment requirement:

- **Bio-infiltration Swale** – See Chapter 7
- **Infiltration** – See Chapter 7
- **Sand Filters** – See Chapter 8
- **Biofiltration Swales** – See Chapter 9
- **Filter Strips** – See Chapter 9
- **Basic Wetpond** – See Chapter 10
- **Wetvault** – See Chapter 10 (see note)
- **Stormwater Treatment Wetland** – See Chapter 10
- **Combined Detention and Wetpool Facilities** – See Chapter 10

<b>Table 3.1 – Treatment Trains for Phosphorus Removal</b>	
<b>First Basic Treatment Facility</b>	<b>Second Treatment Facility</b>
Biofiltration Swale	Basic Sand Filter or Sand Filter Vault
Filter Strip	Linear Sand Filter (no presettling needed)
Linear Sand Filter	Filter Strip
Basic Wetpond	Basic Sand Filter or Sand Filter Vault
Wetvault	Basic Sand Filter or Sand Filter Vault
Stormwater Treatment Wetland	Basic Sand Filter or Sand Filter Vault
Basic Combined Detention and Wetpool	Basic Sand Filter or Sand Filter Vault

<b>Table 3.2 -- Treatment Trains for Dissolved Metals Removal</b>	
<b>First Basic Treatment Facility</b>	<b>Second Treatment Facility</b>
Biofiltration Swale	Basic Sand Filter or Sand Filter Vault or Media Filter <sup>(1)</sup>
Filter Strip	Linear Sand Filter with no pre-settling cell needed
Linear Sand Filter	Filter Strip
Basic Wetpond	Basic Sand Filter or Sand Filter Vault or Media Filter <sup>(1)</sup>
Wetvault	Basic Sand Filter or Sand Filter Vault or Media Filter <sup>(1)</sup>
Basic Combined Detention/Wetpool	Basic Sand Filter or Sand Filter Vault or Media Filter <sup>(1)</sup>
Basic Sand Filter or Sand Filter Vault with a presettling cell if the filter isn't preceded by a detention facility	Media Filter <sup>(1)</sup>
Footnote: (1) The media must be of a nature that has the capability to remove dissolved metals effectively based on at least limited data. Ecology includes Stormfilter's™ leaf compost and zeolite media in this category.	

# Chapter 4 - General Requirements for Storm Water Facilities

---

*Note: All Figures in Chapter 4 are courtesy of King County and the Washington State Department of Ecology.*

This chapter addresses general requirements for treatment facilities. Requirements discussed in this chapter include design volumes and flows, sequencing of facilities, liners, and hydraulic structures for splitting or dispersing flows.

## 4.1 Design Volume and Flow

### 4.1.1 Water Quality Design Storm Volume

The volume of runoff predicted from a 24-hour storm with a 6-month return frequency (a.k.a., 6-month, 24-hour storm).

Wetpool facilities are sized based upon use of the NRCS (formerly known as SCS) curve number equations in Volume III, Chapter 2 for the 6-month, 24-hour storm. Treatment facilities sized by this simple runoff volume-based approach are the same size whether they precede detention, follow detention, or are integral with the detention facility (i.e., a combined detention and wetpool facility).

In general, the 6-month, 24-hour precipitation amount is assumed to be 72 percent of the 2-year, 24-hour amount. Specific precipitation estimates of the 6-month and 2-year, 24-hour storms for Tacoma and other municipalities are listed in Appendix I-B of Volume I. For outlying areas, interpolating between isopluvials for the 2-year, 24-hour precipitation and multiplying by 72% yields the appropriate storm size. Isopluvials for 2-year, 24-hour amounts for Western Washington are reprinted in Volume III.

### 4.1.2 Water Quality Design Flow Rate

***Downstream of Detention Facilities:*** The full 2-year release rate from the detention facility.

An approved continuous runoff model should identify the 2-year return frequency flow rate discharged by a detention facility that is designed to meet the flow duration standard.

***Preceding Detention Facilities or when Detention Facilities are not required:*** The flow rate at or below which 91% of the runoff volume, as estimated by an approved continuous runoff model, will be treated. Design criteria for treatment facilities are assigned to achieve the applicable performance goal at the water quality design flow rate (e.g., 80 percent TSS removal).

- *Off-line facilities:* For treatment facilities not preceded by an equalization or storage basin, and when runoff flow rates exceed the water quality design flow rate, the treatment facility should continue to receive and treat the water quality design flow rate to the applicable treatment performance goal. Only the higher incremental portion of flow rates are bypassed around a treatment facility.

Treatment facilities preceded by an equalization or storage basin may identify a lower water quality design flow rate provided that at least 91 percent of the estimated runoff volume in the time series of a continuous runoff model is treated to the applicable performance goals (e.g., 80 percent TSS removal at the water quality design flow rate and 80 percent TSS removal on an annual average basis).

- *On-line facilities:* Runoff flow rates in excess of the water quality design flow rate can be routed through the facility provided a net pollutant reduction is maintained, and the applicable annual average performance goal is likely to be met.

***Estimation of Water Quality Design Flow Rate for Facilities Preceding Detention or when Detention Facilities are not required:***

Until a continuous runoff model is available that identifies the water quality design flow rate directly, that flow rate shall be estimated using Table 4.1, and its following directions for use:

- Step 1 Determine whether to use the 15-minute time series or the 1-hour time series. At the time of publication of Ecology’s Western Washington Manual, all BMPs except wetpool-types should use the 15-minute time series.
- Step 2 Determine the ratio corresponding with the effective impervious surface associated with the project. For effective impervious areas between two 5 percent increments displayed in the table, a straight line interpolation may be used, or use the higher 5 percent increment value.
- Step 3 Multiply the 2-year return frequency flow for the post-developed site, as predicted by an approved continuous runoff model, by the ratio determined above.

**4.1.3 Flows Requiring Treatment**

Runoff from pollution-generating impervious or pervious surfaces must be treated. Pollution-generating impervious surfaces (PGIS) are those impervious surfaces considered to be a significant source of pollutants in storm water runoff. The glossary in Volume I provides additional definitions and clarification of these terms.

Such surfaces include those which are subject to: vehicular use; industrial activities; or storage of erodible or leachable materials, wastes, or chemicals, and which receive direct rainfall or the run-on or blow-in of rainfall. Erodible or leachable materials, wastes, or chemicals are those



substances which, when exposed to rainfall, measurably alter the physical or chemical characteristics of the rainfall runoff. Examples include erodible soils that are stockpiled, uncovered process wastes, manure, fertilizers, oily substances, ashes, kiln dust, and garbage dumpster leakage. Metal roofs are also considered to be PGIS unless they are coated with an inert, non-leachable material (e.g., baked enamel coating).

A surface, whether paved or not, shall be considered subject to vehicular use if it is regularly used by motor vehicles. The following are considered regularly-used surfaces: roads, unvegetated road shoulders, bike lanes within the traveled lane of a roadway, driveways, parking lots, unfenced fire lanes, vehicular equipment storage yards, and airport runways.

The following are not considered regularly-used surfaces: sidewalks, paved bicycle pathways separated from and not subject to drainage from roads for motor vehicles, fenced fire lanes, and infrequently used maintenance access roads.

Pollution-generating pervious surfaces (PGPS) are any non-impervious surface subject to the use of pesticides and fertilizers or loss of soil. Typical PGPS include lawns, landscaped areas, golf courses, parks, cemeteries, and sports fields.

#### Summary of Areas Needing Treatment

- All runoff from pollution-generating impervious surfaces is to be treated through the water quality facilities specified in Chapter 2 and Chapter 3.
- Lawns and landscaped areas are pervious but also generate runoff into street drainage systems. In those cases the runoff from the pervious areas must be estimated and added to the runoff from impervious areas to size treatment facilities.
- Runoff from backyards can drain into native vegetation in areas designated as open space or buffers. In these cases, the area in native vegetation may be used to provide the requisite water quality treatment, provided it meets the requirements in Chapter 5 under the "Cleared Area Dispersion BMPs," of BMP T5.30 Full Dispersion.
- Drainage from impervious surfaces that are not pollution generating need not be treated and may bypass runoff treatment, if it is not mingled with runoff from pollution generating surfaces.
- Roof runoff is still subject to flow control per Minimum Requirement #7. Note that metal roofs are considered pollution generating unless they are coated with an inert non-leachable material.
- Drainage from areas in native vegetation should not be mixed with untreated runoff from streets and driveways, if possible. It is best to infiltrate or disperse this relatively clean runoff to maximize recharge to shallow ground water, wetlands, and streams.

- If runoff from non-pollution generating surfaces reaches a runoff treatment BMP, flows from those areas must be included in the sizing calculations for the facility. Once runoff from non-pollution generating areas is mixed with runoff from pollution-generating areas, it cannot be separated before treatment.

## 4.2 Sequence of Facilities

The Enhanced Treatment and Phosphorus Removal Menus, described in Chapter 3, include treatment options in which more than one type of treatment facility is used. In those options, the sequence of facilities is prescribed. This is because the specific pollutant removal role of the second or third facility in a treatment often assumes that significant solids settling has already occurred. For example, phosphorus removal using a two-facility treatment relies on the second facility (sand filter) to remove a finer fraction of solids than those removed by the first facility.

There is also the question of whether treatment facilities should be placed upstream or downstream of detention facilities that are needed for flow control purposes. In general, all treatment facilities may be installed upstream of detention facilities, although presettling basins are needed for sand filters and infiltration basins. However, not all treatment facilities can function effectively if located downstream of detention facilities. Those facilities that treat unconcentrated flows, such as filter strips and narrow-area biofilters, are usually not practical downstream of detention facilities. Other types of treatment facilities present special problems that must be considered before placement downstream is advisable.

For instance, prolonged flows discharged by a detention facility that is designed to meet the flow duration standard of Minimum Requirement No. 7 may interfere with proper functioning of basic biofiltration swales and sand filters. Grasses typically specified in the basic biofiltration swale design will not survive. A wet biofilter design would be a better choice.

For sand filters, the prolonged flows may cause extended saturation periods within the filter. Saturated sand can lose all oxygen and become anoxic. If that occurs, some amount of phosphorus captured within the filter may become soluble and released. To prevent long periods of sand saturation, adjustments may be necessary after the sand filter is in operation to bypass some areas of the filter. This bypassing will allow them to drain completely. It may also be possible to employ a different type of facility that is less sensitive to prolonged flows.

Oil control facilities must be located upstream of treatment facilities and as close to the source of oil-generating activity as possible. They should also be located upstream of detention facilities, if possible.

Table 4.2 summarizes placement considerations of treatment facilities in relation to detention.

## 4.3 Setbacks, Slopes, and Embankments

The following guidelines for setbacks, slopes, and embankments are intended to provide for adequate maintenance accessibility to runoff treatment facilities. Setback requirements may also be specified by Tacoma Municipal Code, Uniform Building Code requirements, or other state regulations.

### 4.3.1 Setbacks

The City requires specific setbacks for sites with steep slopes, landslide areas, open water features, springs, wells, and septic tank drain fields. Setbacks from tract lines are necessary for maintenance access and equipment maneuverability. Adequate room for maintenance equipment shall also be considered during site design. Project proponents should consult the Tacoma Municipal Codes to determine all applicable setback requirements. Where a conflict between setbacks occurs, the City shall require compliance with the most stringent of the setback requirements from the various codes/regulations. Required setbacks are as follows or as determined by a qualified geotechnical engineer:

- Minimum spacing between trenches shall be 4 feet measured from the edge of trench.
- Storm water infiltration facilities, unlined wetponds and detention ponds shall be set back at least 100 feet from open water features, drinking water wells, septic tanks or drainfields, and springs used for public drinking water supplies. Infiltration facilities, unlined wetponds and detention ponds upgradient of drinking water supplies and within 1, 5, and 10-year time of travel zones must comply with Health Department requirements (Washington Wellhead Protection Program, DOH, 12/93).
- All systems shall be at least 10 feet from any structure. If necessary, setbacks shall be increased from the minimum 10 feet in order to maintain a 1:1 side slope for future excavation and maintenance
- All systems shall be placed at least 5 feet from any property line. If necessary, setbacks shall be increased from the minimum 5 feet in order to maintain a 1:1 side slope for future excavation and maintenance.
- All facilities shall be setback from sensitive areas, steep slopes, landslide hazard areas, and erosion hazard areas as governed by the Tacoma Municipal Code. Runoff discharged near landslide hazard areas must be evaluated by a geotechnical engineer or qualified geologist. The discharge point shall not be placed on or above slopes greater than 20% or above erosion hazard areas without evaluation by a geotechnical engineer or qualified geologist and City approval.
- For sites with septic systems, infiltration systems, unlined wetponds and detention ponds shall be downgradient of the drainfield unless the site topography clearly prohibits subsurface flows from intersecting the drainfield.

Additional setbacks for specific storm water facilities will be noted in the appropriate section.

#### **4.3.2 Side Slopes and Embankments**

- Side slopes shall not exceed a slope of 3H:1V. Moderately undulating slopes are acceptable and can provide a more natural setting for the facility. In general, gentle side slopes improve the aesthetic attributes of the facility and enhance safety.
- Interior side slopes may be retaining walls, if the design is prepared and stamped by a licensed civil engineer. A fence should be provided along the top of the wall.
- Maintenance access shall be provided through an access ramp or other adequate means (see Volume III, Chapter 3, Section 3.3.1).
- Embankments that impound water must comply with the Washington State Dam Safety Regulations (Chapter 173-175 WAC). If the impoundment has a storage capacity, including both water and sediment storage volumes, greater than 10 acre-feet (435,600 cubic feet or 3.26 million gallons) above natural ground level, then dam safety design and review are required by the Department of Ecology. See Volume III, Chapter 3 for more detail concerning Detention Ponds.

### **4.4 Facility Liners**

Liners are intended to reduce the likelihood that pollutants in storm water will reach groundwater when runoff treatment facilities are constructed. In addition to groundwater protection considerations, some facility types require permanent water for proper functioning. An example is the first cell of a wetpond.

Treatment liners amend the soil with materials that treat storm water before it reaches more freely draining soils. They have slow rates of infiltration, generally less than 2.4 inches per hour ( $1.7 \times 10^{-3}$  cm/s), but not as slow as low permeability liners. Treatment liners may use in-place native soils or imported soils.

Low permeability liners reduce infiltration to a very slow rate, generally less than 0.02 inches per hour ( $1.4 \times 10^{-5}$  cm/s). These types of liners should be used for industrial or commercial sites with a potential for high pollutant loading in the storm water runoff. Low permeability liners may be fashioned from compacted till, clay, geomembrane, or concrete. Till liners are preferred because of their general resilience and ease of maintenance.

#### **4.4.1 General Design Criteria**

- Table 4.3 shows recommendations for the type of liner generally best suited for use with various runoff treatment facilities.
- Liners shall be evenly placed over the bottom and/or sides of the treatment area of the facility as indicated in Table 4.3. Areas above the treatment volume that are required to pass flows greater than the

water quality treatment flow (or volume) need not be lined. However, the lining must be extended to the top of the interior side slope and anchored if it cannot be permanently secured by other means.

- For low permeability liners, the following criteria apply:
  1. Where the seasonal high groundwater elevation is likely to contact a low permeability liner, liner buoyancy may be a concern. A low permeability liner shall not be used in this situation unless evaluated and recommended by a geotechnical engineer.
  2. Where grass must be planted over a low permeability liner per the facility design, a minimum of 6 inches of good topsoil or compost-amended native soil (2 inches compost tilled into 6 inches of native till soil) must be placed over the liner in the area to be planted. Twelve inches of cover is preferred.
- If a treatment liner will be below the seasonal high water level, the pollutant removal performance of the liner must be evaluated by a geotechnical or groundwater specialist and found to be as protective as if the liner were above the level of the groundwater.

See Sections 4.4.2 and 4.4.3 for more specific design criteria for treatment liners and low permeability liners.

#### **4.4.2 Design Criteria for Treatment Liners**

This section presents the design criteria for treatment liners.

- A two-foot thick layer of soil with a minimum organic content of 5% AND a minimum cation exchange capacity (CEC) of 5 milliequivalents/100 grams can be used as a treatment layer beneath a water quality or detention facility.
- To demonstrate that in-place soils meet the above criteria, one sample per 1,000 square feet of facility area shall be tested. Each sample shall be a composite of subsamples taken throughout the depth of the treatment layer (usually two to six feet below the expected facility invert).
- Typically, side wall seepage is not a concern if the seepage flows through the same stratum as the bottom of the treatment BMP. However, if the treatment soil is an engineered soil or has very low permeability, the potential to bypass the treatment soil through the side walls may be significant. In those cases, the treatment BMP side walls may be lined with at least 18 inches of treatment soil, as described above, to prevent untreated seepage. This lesser soil thickness is based on unsaturated flow as a result of alternating wet-dry periods.
- Organic content shall be measured on a dry weight basis using ASTM D2974.
- Cation exchange capacity (CEC) shall be tested using EPA laboratory method 9081.

- Certification by a soils testing laboratory that imported soil meets the organic content and CEC criteria above shall be provided to the City of Tacoma.
- Animal manures used in treatment soil layers must be sterilized because of potential for bacterial contamination of the groundwater.

#### **4.4.3 Design Criteria for Low Permeability Liner Options**

This section presents the design criteria for each of the following four low permeability liner options: compacted till liners, clay liners, geomembrane liners, and concrete liners.

##### **Compacted Till Liners**

- Liner thickness shall be 18 inches after compaction.
- Soil shall be compacted to 95% minimum dry density, modified proctor method (ASTM D-1557).
- A different depth and density sufficient to retard the infiltration rate to  $2.4 \times 10^{-5}$  inches per minute ( $1 \times 10^{-6}$  cm/s) may also be used instead of the above criteria.
- Soil should be placed in 6-inch lifts.

##### **Clay Liners**

- Liner thickness shall be 12 inches.
- Clay shall be compacted to 95% minimum dry density, modified proctor method (ASTM D-1557).
- A different depth and density sufficient to retard the infiltration rate to  $2.4 \times 10^{-5}$  inches per minute ( $1 \times 10^{-6}$  cm/s) may also be used instead of the above criteria.
- The slope of clay liners must be restricted to 3H: 1V for all areas requiring soil cover; otherwise, the soil layer must be stabilized by another method so that soil slippage into the facility does not occur. Any alternative soil stabilization method must take maintenance access into consideration.
- Where clay liners form the sides of ponds, the interior side slope should not be steeper than 3H:1V, irrespective of fencing. This restriction is to ensure that anyone falling into the pond may safely climb out.

##### **Geomembrane Liners**

- Geomembrane liners shall be ultraviolet (UV) light resistant and have a minimum thickness of 30 mils. A thickness of 40 mils shall be used in areas of maintenance access or where heavy machinery must be operated over the membrane.
- Geomembranes shall be bedded according to the manufacturer's recommendations.
- Liners shall be installed so that they can be covered with 12 inches of top dressing forming the bottom and sides of the water quality facility,

except for liner sand filters. Top dressing shall consist of 6 inches of crushed rock covered with 6 inches of native soil. The rock layer is to mark the location of the liner for future maintenance operations. As an alternative to crushed rock, 12 inches of native soil may be used if orange plastic “safety fencing” or another highly-visible, continuous marker is embedded 6 inches above the membrane.

- If possible, liners should be of a contrasting color so that maintenance workers are aware of any areas where a liner may have become exposed when maintaining the facility.
- Geomembrane liners shall not be used on slopes steeper than 5H:1V to prevent the top dressing material from slipping. Textured liners may be used on slopes up to 3H:1V upon recommendation by a geotechnical engineer that the top dressing will be stable for all site conditions, including maintenance.

#### **Concrete Liners**

- Portland cement liners are allowed irrespective of facility size, and shotcrete may be used on slopes. However, specifications must be developed by a professional engineer who certifies the liner against cracking or losing water retention ability under expected conditions of operation, including facility maintenance operations. Weight of maintenance equipment can be up to 80,000 pounds when fully loaded.
- Asphalt concrete may not be used for liners due to its permeability to many organic pollutants.
- If grass is to be grown over a concrete liner, slopes must be no steeper than 5H:1V to prevent the top dressing material from slipping.

## **4.5 Hydraulic Structures**

### **4.5.1 Flow Splitter Designs**

Many water quality (WQ) facilities can be designed as flow-through or on-line systems with flows above the WQ design flow or volume simply passing through the facility at a lower pollutant removal efficiency. However, it is sometimes desirable to restrict flows to WQ treatment facilities and bypass the remaining higher flows around them through off-line facilities. This can be accomplished by splitting flows in excess of the WQ design flow upstream of the facility and diverting higher flows to a bypass pipe or channel. The bypass typically enters a detention pond or the downstream receiving drainage system, depending on flow control requirements. In most cases, it is a designer’s choice whether WQ facilities are designed as on-line or off-line; an exception is oil/water separators, which must be designed off-line.

A crucial factor in designing flow splitters is to ensure that low flows are delivered to the treatment facility up to the WQ design flow rate. Above this rate, additional flows are diverted to the bypass system with minimal increase in head at the flow splitter structure to avoid surcharging the WQ facility under high flow conditions.

Flow splitters are typically manholes or vaults with concrete baffles. In place of baffles, the splitter mechanism may be a half tee section with a solid top and an orifice in the bottom of the tee section. A full tee option may also be used as described below in the “General Design Criteria.” Two possible design options for flow splitters are shown in Figure 4.1 and Figure 4.2 (King County). Other equivalent designs that achieve the result of splitting low flows and diverting higher flows around the facility are also acceptable.

### **General Design Criteria**

- A flow splitter must be designed to deliver the WQ design flow rate specified in this volume to the WQ treatment facility. For the basic size sand filter, which is sized based on volume, use the WQ design flow rate to design the splitter. For the large sand filter, use the 2-year flow rate or the flow rate that corresponds with treating 91 percent of the runoff volume of a long-term time series predicted by an approved continuous runoff model.
- The top of the weir must be located at the water surface for the design flow. Remaining flows enter the bypass line. Flows modeled using a continuous simulation model should use 15-minute time steps, if available. Otherwise use 1-hour time steps.
- The maximum head must be minimized for flow in excess of the WQ design flow. Specifically, flow to the WQ facility at the 100-year water surface must not increase the design WQ flow by more than 10%.
- Either design shown in Figure 4.1 or Figure 4.2 or an equivalent design may be used.
- As an alternative to using a solid top plate in Figure 4.2, a full tee section may be used with the top of the tee at the 100-year water surface. This alternative would route emergency overflows (if the overflow pipe were plugged) through the WQ facility rather than back up from the manhole.
- Special applications, such as roads, may require the use of a modified flow splitter. The baffle wall may be fitted with a notch and adjustable weir plate to proportion runoff volumes other than high flows.
- For ponding facilities, back water effects must be included in designing the height of the standpipe in the manhole.
- Ladder or step and handhold access must be provided. If the weir wall is higher than 36 inches, two ladders, one to either side of the wall, must be used.

### **Materials**

- The splitter baffle may be installed in a Type 2 manhole or vault.
- The baffle wall must be made of reinforced concrete or another suitable material resistant to corrosion, and have a minimum 4-inch thickness. The minimum clearance between the top of the baffle wall and the bottom of the manhole cover must be 4 feet; otherwise, dual access points should be provided.



- All metal parts must be corrosion resistant. Examples of preferred materials include aluminum, stainless steel, and plastic. Zinc and galvanized materials are discouraged because of aquatic toxicity. Painted metal parts should not be used because of poor longevity.

#### **4.5.2 Flow Spreading Options**

Flow spreaders function to uniformly spread flows across the inflow portion of water quality facilities (e.g., sand filter, biofiltration swale, or filter strip). There are five flow spreader options presented in this section:

- Option A – Anchored plate
- Option B – Concrete sump box
- Option C – Notched curb spreader
- Option D – Through-curb ports
- Option E – Interrupted curb

Options A through C can be used for spreading flows that are concentrated. Any one of these options can be used when spreading is required by the facility design criteria. Options A through C can also be used for unconcentrated flows, and in some cases must be used, such as to correct for moderate grade changes along a filter strip.

Options D and E are only for flows that are already unconcentrated and enter a filter strip or continuous inflow biofiltration swale. Other flow spreader options are possible with approval from the reviewing authority.

#### **General Design Criteria**

- Where flow enters the flow spreader through a pipe, it is recommended that the pipe be submerged to the extent practical to dissipate energy as much as possible.
- For higher inflows (greater than 5 cfs for the 100-yr storm), a Type 1 catch basin should be positioned in the spreader and the inflow pipe should enter the catch basin with flows exiting through the top grate. The top of the grate should be lower than the level spreader plate, or if a notched spreader is used, lower than the bottom of the v-notches.
- Table 4.5 provides general guidance for rock protection at outfalls.

#### **Option A -- Anchored Plate (Figure 4.3)**

- An anchored plate flow spreader must be preceded by a sump having a minimum depth of 8 inches and minimum width of 24 inches. If not otherwise stabilized, the sump area must be lined to reduce erosion and to provide energy dissipation.
- The top surface of the flow spreader plate must be level, projecting a minimum of 2 inches above the ground surface of the water quality facility, or V-notched with notches 6 to 10 inches on center and 1 to 6 inches deep (use shallower notches with closer spacing). Alternative designs may also be used.
- A flow spreader plate must extend horizontally beyond the bottom width of the facility to prevent water from eroding the side slope. The

horizontal extent should be such that the bank is protected for all flows up to the 100-year flow or the maximum flow that will enter the Water Quality (WQ) facility.

- Flow spreader plates must be securely fixed in place.
- Flow spreader plates may be made of either wood, metal, fiberglass reinforced plastic, or other durable material. If wood, pressure treated 4 by 10-inch lumber or landscape timbers are acceptable.
- Anchor posts must be 4-inch square concrete, tubular stainless steel, or other material resistant to decay.

#### **Option B -- Concrete Sump Box (Figure 4.4)**

- The wall of the downstream side of a rectangular concrete sump box must extend a minimum of 2 inches above the treatment bed. This serves as a weir to spread the flows uniformly across the bed.
- The downstream wall of a sump box must have “wing walls” at both ends. Side walls and returns must be slightly higher than the weir so that erosion of the side slope is minimized.
- Concrete for a sump box can be either cast-in-place or precast, but the bottom of the sump must be reinforced with wire mesh for cast-in-place sumps.
- Sump boxes must be placed over bases that consists of 4 inches of crushed rock, 5/8-inch minus to help assure the sump remains level.

#### **Option C -- Notched Curb Spreader (Figure 4.5)**

Notched curb spreader sections must be made of extruded concrete laid side-by-side and level. Typically five “teeth” per four-foot section provide good spacing. The space between adjacent “teeth” forms a v-notch.

#### **Option D -- Through-Curb Ports (Figure 4.6)**

Unconcentrated flows from paved areas entering filter strips or continuous inflow biofiltration swales can use curb ports or interrupted curbs (Option E) to allow flows to enter the strip or swale. Curb ports use fabricated openings that allow concrete curbing to be poured or extruded while still providing an opening through the curb to admit water to the WQ facility.

Openings in the curb must be at regular intervals but at least every 6 feet (minimum). The width of each curb port opening must be a minimum of 11 inches. Approximately 15 percent or more of the curb section length should be in open ports, and no port should discharge more than about 10 percent of the flow.

#### **Option E -- Interrupted Curb (No Figure)**

*Interrupted curbs* are sections of curb placed to have gaps spaced at regular intervals along the total width (or length, depending on facility) of the treatment area. At a minimum, gaps must be every 6 feet to allow distribution of flows into the treatment facility before they become too concentrated. The opening must be a minimum of 11 inches. As a

general rule, no opening should discharge more than 10 percent of the overall flow entering the facility.

### **4.5.3 Outfall Systems**

Properly designed outfalls are critical to reducing the chance of adverse impacts as the result of concentrated discharges from pipe systems and culverts, both onsite and downstream. Outfall systems include rock splash pads, flow dispersal trenches, gabion or other energy dissipaters, and tightline systems. A tightline system is typically a continuous length of pipe used to convey flows down a steep or sensitive slope with appropriate energy dissipation at the discharge end.

#### **General Design Criteria**

Provided below are general design criteria for both Outfall Features and Tightline Systems.

#### **Outfall Features**

At a minimum, all outfalls must be provided with a rock splash pad (see Figure 4.7) except as specified below and in Table 4.5:

- The flow dispersal trenches shown in Figures 4.8 and 4.9 should only be used when both criteria below are met:
  1. An outfall is necessary to disperse concentrated flows across uplands where no conveyance system exists and the natural (existing) discharge is unconcentrated; and
  2. The 100-year peak discharge rate is less than or equal to 0.5 cfs.
- For freshwater outfalls with a design velocity greater than 10 fps, a gabion dissipater or engineered energy dissipater may be required. There are many possible designs.

*Note: The gabion outfall detail shown in Figure 4.10 is illustrative only. A design engineered to specific site conditions must be developed.*

- Tightline systems may be needed to prevent aggravation or creation of a downstream erosion problem.
- In marine waters, rock splash pads and gabion structures are not recommended due to corrosion and destruction of the structure, particularly in high energy environments. Diffuser Tee structures, such as that depicted in Figure 4.11, are also not generally recommended in or above the intertidal zone. They may be acceptable in low bank or rock shoreline locations. Stilling basins or bubble-up structures are acceptable. Generally, tightlines trenched to extreme low water or dissipation of the discharge energy above the ordinary high water line are preferred. Outfalls below extreme low water may still need an energy dissipation device (e.g., a tee structure) to prevent nearby erosion.

- Engineered energy dissipaters, including stilling basins, drop pools, hydraulic jump basins, baffled aprons, and bucket aprons, are required for outfalls with design velocity greater than 20 fps. These should be designed using published or commonly known techniques found in such references as *Hydraulic Design of Energy Dissipaters for Culverts and Channels*, published by the Federal Highway Administration of the United States Department of Transportation; *Open Channel Flow*, by V.T. Chow; *Hydraulic Design of Stilling Basins and Energy Dissipaters*, EM 25, Bureau of Reclamation (1978); and other publications, such as those prepared by the Soil Conservation Service (now Natural Resource Conservation Service).
- Alternate mechanisms may be used, such as bubble-up structures, that eventually drain, and structures fitted with reinforced concrete posts. If any alternate mechanisms are to be considered, they should be designed using sound hydraulic principles and consideration of ease of construction and maintenance.

### **Tightline Systems**

- Mechanisms that reduce velocity prior to discharge from an outfall are encouraged. Some of these are drop manholes and rapid expansion into pipes of much larger size. Other discharge end features may be used to dissipate the discharge energy. An example of an end feature is the use of a Diffuser Tee with holes in the front half, as shown in Figure 4.11.

*Note: Storm water outfalls submerged in a marine environment can be subject to plugging due to biological growth and shifting debris and sediments. Therefore, unless intensive maintenance is regularly performed, they may not meet their designed function.*

- New pipe outfalls can provide an opportunity for low-cost fish habitat improvements. For example, an alcove of low-velocity water can be created by constructing the pipe outfall and associated energy dissipater back from the stream edge and digging a channel, over widened to the upstream side, from the outfall to the stream (as shown in Figure 4.12). Overwintering juvenile and migrating adult salmonids may use the alcove as shelter during high flows. Potential habitat improvements should be discussed with the Washington Department of Fish and Wildlife biologist prior to inclusion in design.
- Bank stabilization, bioengineering and habitat features may be required for disturbed areas.
- Outfall structures should be located where they minimize impacts to fish, shellfish, and their habitats.
- One caution to note is that the in-stream sample gabion mattress energy dissipater may not be acceptable within the ordinary high water mark of fish-bearing waters or where gabions will be subject to abrasion from upstream channel sediments. A gabion basket located outside the ordinary high water mark should be considered for these applications.

*Note: Please see Tacoma Municipal Code for additional requirements. A Hydraulic Project Approval (Chapter 77.55 RCW) may be required for any work within the ordinary high water mark. Other provisions of that RCW or the Hydraulics Code - Chapter 220-110 WAC may also apply.*

### **Tightline Systems**

- Outfall tightlines may be installed in trenches with standard bedding on slopes up to 20%. In order to minimize disturbance to slopes greater than 20%, it is recommended that tightlines be placed at grade with proper pipe anchorage and support.
- Except as indicated above, tightlines or conveyances that traverse the marine intertidal zone and connect to outfalls must be buried to a depth sufficient to avoid exposure of the line during storm events or future changes in beach elevation. If non-native material is used to bed the tightline, such material shall be covered with at least 3 feet of native bed material or equivalent.
- High density polyethylene pipe (HDPP) tightlines must be designed to address the material limitations, particularly thermal expansion and contraction and pressure design, as specified by the manufacturer. The coefficient of thermal expansion and contraction for solid wall polyethylene pipe (SWPE) is on the order of 0.001 inch per foot per Fahrenheit degree. Sliding sleeve connections must be used to address this thermal expansion and contraction. These sleeve connections consist of a section of the appropriate length of the next larger size diameter of pipe into which the outfall pipe is fitted. These sleeve connections must be located as close to the discharge end of the outfall system as is practical.
- Due to the ability of HDPP tightlines to transmit flows of very high energy, special consideration for energy dissipation must be made. Details of a sample gabion mattress energy dissipater have been provided as Figure 4.10. Flows of very high energy will require a specifically engineered energy dissipater structure.

## **4.6 Maintenance Standards for Drainage Facilities**

The facility-specific maintenance standards contained in this section are intended to be conditions for determining if maintenance actions are required as identified through inspection. They are not intended to be measures of the facility's required condition at all times between inspections. In other words, exceedence of these conditions at any time between inspections and/or maintenance does not automatically constitute a violation of these standards. However, based upon inspection observations, the inspection and maintenance schedules shall be adjusted to minimize the length of time that a facility is in a condition that requires a maintenance action.

## No. 1 – Detention Ponds

Maintenance Component	Defect	Conditions When Maintenance Is Needed	Results Expected When Maintenance Is Performed
General	Trash & Debris	Any trash and debris which exceed 5 cubic feet per 1,000 square feet (this is about equal to the amount of trash it would take to fill up one standard size garbage can). In general, there should be no visual evidence of dumping.  If less than threshold all trash and debris will be removed as part of next scheduled maintenance.	Trash and debris cleared from site.
	Poisonous Vegetation and noxious weeds	Any poisonous or nuisance vegetation which may constitute a hazard to maintenance personnel or the public.  Any evidence of noxious weeds as defined by State or local regulations. (Apply requirements of adopted IPM policies for the use of herbicides).	No danger of poisonous vegetation where maintenance personnel or the public might normally be. (Coordinate with local health department)  Complete eradication of noxious weeds may not be possible. Compliance with State or local eradication policies required
	Contaminants and Pollution	Any evidence of oil, gasoline, contaminants or other pollutants  (Coordinate removal/cleanup with local water quality response agency).	No contaminants or pollutants present.
	Rodent Holes	Any evidence of rodent holes if facility is acting as a dam or berm, or any evidence of water piping through dam or berm via rodent holes.	Rodents destroyed and dam or berm repaired. (Coordinate with local health department; coordinate with Ecology Dam Safety Office if pond exceeds 10 acre-feet.)
	Beaver Dams	Dam results in change or function of the facility.	Facility is returned to design function.  (Coordinate trapping of beavers and removal of dams with appropriate permitting agencies)
	Insects	When insects such as wasps and hornets interfere with maintenance activities.	Insects destroyed or removed from site.  Apply insecticides in compliance with adopted IPM policies
	Tree Growth and Hazard Trees	Tree growth does not allow maintenance access or interferes with maintenance activity (i.e., slope mowing, silt removal, vactoring, or equipment movements). If trees are not interfering with access or maintenance, do not remove  If dead, diseased, or dying trees are identified  (Use a certified Arborist to determine health of tree or removal requirements)	Trees do not hinder maintenance activities. Harvested trees should be recycled into mulch or other beneficial uses (e.g., alders for firewood).  Remove hazard Trees

## No. 1 – Detention Ponds

Maintenance Component	Defect	Conditions When Maintenance Is Needed	Results Expected When Maintenance Is Performed
Side Slopes of Pond	Erosion	Eroded damage over 2 inches deep where cause of damage is still present or where there is potential for continued erosion.  Any erosion observed on a compacted berm embankment.	Slopes should be stabilized using appropriate erosion control measure(s); e.g., rock reinforcement, planting of grass, compaction.  If erosion is occurring on compacted berms a licensed civil engineer should be consulted to resolve source of erosion.
Storage Area	Sediment	Accumulated sediment that exceeds 10% of the designed pond depth unless otherwise specified or affects inletting or outletting condition of the facility.	Sediment cleaned out to designed pond shape and depth; pond reseeded if necessary to control erosion.
	Liner (If Applicable)	Liner is visible and has more than three 1/4-inch holes in it.	Liner repaired or replaced. Liner is fully covered.
Pond Berms (Dikes)	Settlements	Any part of berm which has settled 4 inches lower than the design elevation.  If settlement is apparent, measure berm to determine amount of settlement.  Settling can be an indication of more severe problems with the berm or outlet works. A licensed civil engineer should be consulted to determine the source of the settlement.	Dike is built back to the design elevation.
	Piping	Discernable water flow through pond berm. Ongoing erosion with potential for erosion to continue.  (Recommend a Geotechnical engineer be called in to inspect and evaluate condition and recommend repair of condition.	Piping eliminated. Erosion potential resolved.
Emergency Overflow/ Spillway and Berms over 4 feet in height.	Tree Growth	Tree growth on emergency spillways creates blockage problems and may cause failure of the berm due to uncontrolled overtopping.  Tree growth on berms over 4 feet in height may lead to piping through the berm which could lead to failure of the berm.	Trees should be removed. If root system is small (base less than 4 inches) the root system may be left in place. Otherwise the roots should be removed and the berm restored. A licensed civil engineer should be consulted for proper berm/spillway restoration.
	Piping	Discernable water flow through pond berm. Ongoing erosion with potential for erosion to continue.  (Recommend a Geotechnical engineer be called in to inspect and evaluate condition and recommend repair of condition.	Piping eliminated. Erosion potential resolved.

## No. 1 – Detention Ponds

Maintenance Component	Defect	Conditions When Maintenance Is Needed	Results Expected When Maintenance Is Performed
Emergency Overflow/ Spillway	Emergency Overflow/ Spillway	Only one layer of rock exists above native soil in area five square feet or larger, or any exposure of native soil at the top of out flow path of spillway.  (Rip-rap on inside slopes need not be replaced.)	Rocks and pad depth are restored to design standards.
	Erosion	See "Side Slopes of Pond"	



## No. 2 – Infiltration

Maintenance Component	Defect	Conditions When Maintenance Is Needed	Results Expected When Maintenance Is Performed
General	Trash & Debris	See "Detention Ponds" (No. 1).	See "Detention Ponds" (No. 1).
	Poisonous/Noxious Vegetation	See "Detention Ponds" (No. 1).	See "Detention Ponds" (No. 1).
	Contaminants and Pollution	See "Detention Ponds" (No. 1).	See "Detention Ponds" (No. 1).
	Rodent Holes	See "Detention Ponds" (No. 1).	See "Detention Ponds" (No. 1).
Storage Area	Sediment	Water ponding in infiltration pond after rainfall ceases and appropriate time allowed for infiltration.  (A percolation test pit or test of facility indicates facility is only working at 90% of its designed capabilities. If two inches or more sediment is present, remove).	Sediment is removed and/or facility is cleaned so that infiltration system works according to design.
Filter Bags (if applicable)	Filled with Sediment and Debris	Sediment and debris fill bag more than 1/2 full.	Filter bag is replaced or system is redesigned.
Rock Filters	Sediment and Debris	By visual inspection, little or no water flows through filter during heavy rain storms.	Gravel in rock filter is replaced.
Side Slopes of Pond	Erosion	See "Detention Ponds" (No. 1).	See "Detention Ponds" (No. 1).
Emergency Overflow Spillway and Berms over 4 feet in height.	Tree Growth	See "Detention Ponds" (No. 1).	See "Detention Ponds" (No. 1).
	Piping	See "Detention Ponds" (No. 1).	See "Detention Ponds" (No. 1).
Emergency Overflow Spillway	Rock Missing	See "Detention Ponds" (No. 1).	See "Detention Ponds" (No. 1).
	Erosion	See "Detention Ponds" (No. 1).	See "Detention Ponds" (No. 1).
Pre-settling Ponds and Vaults	Facility or sump filled with Sediment and/or debris	6" or designed sediment trap depth of sediment.	Sediment is removed.

### No. 3 – Closed Detention Systems (Tanks/Vaults)

Maintenance Component	Defect	Conditions When Maintenance is Needed	Results Expected When Maintenance is Performed
Storage Area	Plugged Air Vents	One-half of the cross section of a vent is blocked at any point or the vent is damaged.	Vents open and functioning.
	Debris and Sediment	Accumulated sediment depth exceeds 10% of the diameter of the storage area for 1/2 length of storage vault or any point depth exceeds 15% of diameter.  (Example: 72-inch storage tank would require cleaning when sediment reaches depth of 7 inches for more than 1/2 length of tank.)	All sediment and debris removed from storage area.
	Joints Between Tank/Pipe Section	Any openings or voids allowing material to be transported into facility.  (Will require engineering analysis to determine structural stability).	All joint between tank/pipe sections are sealed.
	Tank Pipe Bent Out of Shape	Any part of tank/pipe is bent out of shape more than 10% of its design shape. (Review required by engineer to determine structural stability).	Tank/pipe repaired or replaced to design.
	Vault Structure Includes Cracks in Wall, Bottom, Damage to Frame and/or Top Slab	Cracks wider than 1/2-inch and any evidence of soil particles entering the structure through the cracks, or maintenance/inspection personnel determines that the vault is not structurally sound.  Cracks wider than 1/2-inch at the joint of any inlet/outlet pipe or any evidence of soil particles entering the vault through the walls.	Vault replaced or repaired to design specifications and is structurally sound.  No cracks more than 1/4-inch wide at the joint of the inlet/outlet pipe.
Manhole	Cover Not in Place	Cover is missing or only partially in place. Any open manhole requires maintenance.	Manhole is closed.
	Locking Mechanism Not Working	Mechanism cannot be opened by one maintenance person with proper tools. Bolts into frame have less than 1/2 inch of thread (may not apply to self-locking lids).	Mechanism opens with proper tools.
	Cover Difficult to Remove	One maintenance person cannot remove lid after applying normal lifting pressure. Intent is to keep cover from sealing off access to maintenance.	Cover can be removed and reinstalled by one maintenance person.
	Ladder Rungs Unsafe	Ladder is unsafe due to missing rungs, misalignment, not securely attached to structure wall, rust, or cracks.	Ladder meets design standards. Allows maintenance person safe access.
Catch Basins	See "Catch Basins" (No. 5)	See "Catch Basins" (No. 5).	See "Catch Basins" (No. 5).

#### No. 4 – Control Structure/Flow Restrictor

Maintenance Component	Defect	Condition When Maintenance is Needed	Results Expected When Maintenance is Performed
General	Trash and Debris (Includes Sediment)	Material exceeds 25% of sump depth or 1 foot below orifice plate.	Control structure orifice is not blocked. All trash and debris removed.
	Structural Damage	Structure is not securely attached to manhole wall.	Structure securely attached to wall and outlet pipe.
		Structure is not in upright position (allow up to 10% from plumb).	Structure in correct position.
		Connections to outlet pipe are not watertight and show signs of rust.	Connections to outlet pipe are water tight; structure repaired or replaced and works as designed.
		Any holes--other than designed holes--in the structure.	Structure has no holes other than designed holes.
Cleanout Gate	Damaged or Missing	Cleanout gate is not watertight or is missing.	Gate is watertight and works as designed.
		Gate cannot be moved up and down by one maintenance person.	Gate moves up and down easily and is watertight.
		Chain/rod leading to gate is missing or damaged.	Chain is in place and works as designed.
		Gate is rusted over 50% of its surface area.	Gate is repaired or replaced to meet design standards.
Orifice Plate	Damaged or Missing	Control device is not working properly due to missing, out of place, or bent orifice plate.	Plate is in place and works as designed.
	Obstructions	Any trash, debris, sediment, or vegetation blocking the plate.	Plate is free of all obstructions and works as designed.
Overflow Pipe	Obstructions	Any trash or debris blocking (or having the potential of blocking) the overflow pipe.	Pipe is free of all obstructions and works as designed.
Manhole	See "Closed Detention Systems" (No. 3).	See "Closed Detention Systems" (No. 3).	See "Closed Detention Systems" (No. 3).
Catch Basin	See "Catch Basins" (No. 5).	See "Catch Basins" (No. 5).	See "Catch Basins" (No. 5).

## No. 5 – Catch Basins

Maintenance Component	Defect	Conditions When Maintenance is Needed	Results Expected When Maintenance is performed
General	Trash & Debris	Trash or debris which is located immediately in front of the catch basin opening or is blocking inletting capacity of the basin by more than 10%.	No Trash or debris located immediately in front of catch basin or on grate opening.
		Trash or debris (in the basin) that exceeds 60 percent of the sump depth as measured from the bottom of basin to invert of the lowest pipe into or out of the basin, but in no case less than a minimum of six inches clearance from the debris surface to the invert of the lowest pipe.	No trash or debris in the catch basin.
		Trash or debris in any inlet or outlet pipe blocking more than 1/3 of its height.	Inlet and outlet pipes free of trash or debris.
		Dead animals or vegetation that could generate odors that could cause complaints or dangerous gases (e.g., methane).	No dead animals or vegetation present within the catch basin.
	Sediment	Sediment (in the basin) that exceeds 60 percent of the sump depth as measured from the bottom of basin to invert of the lowest pipe into or out of the basin, but in no case less than a minimum of 6 inches clearance from the sediment surface to the invert of the lowest pipe.	No sediment in the catch basin
	Structure Damage to Frame and/or Top Slab	Top slab has holes larger than 2 square inches or cracks wider than 1/4 inch  (Intent is to make sure no material is running into basin).	Top slab is free of holes and cracks.
		Frame not sitting flush on top slab, i.e., separation of more than 3/4 inch of the frame from the top slab. Frame not securely attached	Frame is sitting flush on the riser rings or top slab and firmly attached.
	Fractures or Cracks in Basin Walls/ Bottom	Maintenance person judges that structure is unsound.	Basin replaced or repaired to design standards.
		Grout fillet has separated or cracked wider than 1/2 inch and longer than 1 foot at the joint of any inlet/outlet pipe or any evidence of soil particles entering catch basin through cracks.	Pipe is regouted and secure at basin wall.
	Settlement/ Misalignment	If failure of basin has created a safety, function, or design problem.	Basin replaced or repaired to design standards.
	Vegetation	Vegetation growing across and blocking more than 10% of the basin opening.	No vegetation blocking opening to basin.
		Vegetation growing in inlet/outlet pipe joints that is more than six inches tall and less than six inches apart.	No vegetation or root growth present.

## No. 5 – Catch Basins

Maintenance Component	Defect	Conditions When Maintenance is Needed	Results Expected When Maintenance is performed
	Contamination and Pollution	See "Detention Ponds" (No. 1).	No pollution present.
Catch Basin Cover	Cover Not in Place	Cover is missing or only partially in place. Any open catch basin requires maintenance.	Catch basin cover is closed
	Locking Mechanism Not Working	Mechanism cannot be opened by one maintenance person with proper tools. Bolts into frame have less than 1/2 inch of thread.	Mechanism opens with proper tools.
	Cover Difficult to Remove	One maintenance person cannot remove lid after applying normal lifting pressure.  (Intent is keep cover from sealing off access to maintenance.)	Cover can be removed by one maintenance person.
Ladder	Ladder Rungs Unsafe	Ladder is unsafe due to missing rungs, not securely attached to basin wall, misalignment, rust, cracks, or sharp edges.	Ladder meets design standards and allows maintenance person safe access.
Metal Grates (If Applicable)	Grate opening Unsafe	Grate with opening wider than 7/8 inch.	Grate opening meets design standards.
	Trash and Debris	Trash and debris that is blocking more than 20% of grate surface inletting capacity.	Grate free of trash and debris.
	Damaged or Missing.	Grate missing or broken member(s) of the grate.	Grate is in place and meets design standards.

**No. 6 – Debris Barriers (e.g., Trash Racks)**

Maintenance Components	Defect	Condition When Maintenance is Needed	Results Expected When Maintenance is Performed
General	Trash and Debris	Trash or debris that is plugging more than 20% of the openings in the barrier.	Barrier cleared to design flow capacity.
Metal	Damaged/ Missing Bars.	Bars are bent out of shape more than 3 inches.	Bars in place with no bends more than 3/4 inch.
		Bars are missing or entire barrier missing.	Bars in place according to design.
		Bars are loose and rust is causing 50% deterioration to any part of barrier.	Barrier replaced or repaired to design standards.
	Inlet/Outlet Pipe	Debris barrier missing or not attached to pipe	Barrier firmly attached to pipe

## No. 7 – Energy Dissipaters

Maintenance Components	Defect	Conditions When Maintenance is Needed	Results Expected When Maintenance is Performed
External:			
Rock Pad	Missing or Moved Rock	Only one layer of rock exists above native soil in area five square feet or larger, or any exposure of native soil.	Rock pad replaced to design standards.
	Erosion	Soil erosion in or adjacent to rock pad.	Rock pad replaced to design standards.
Dispersion Trench	Pipe Plugged with Sediment	Accumulated sediment that exceeds 20% of the design depth.	Pipe cleaned/flushed so that it matches design.
	Not Discharging Water Properly	Visual evidence of water discharging at concentrated points along trench (normal condition is a "sheet flow" of water along trench). Intent is to prevent erosion damage.	Trench redesigned or rebuilt to standards.
	Perforations Plugged.	Over 1/2 of perforations in pipe are plugged with debris and sediment.	Perforated pipe cleaned or replaced.
	Water Flows Out Top of "Distributor" Catch Basin.	Maintenance person observes or receives credible report of water flowing out during any storm less than the design storm or its causing or appears likely to cause damage.	Facility rebuilt or redesigned to standards.
	Receiving Area Over-Saturated	Water in receiving area is causing or has potential of causing landslide problems.	No danger of landslides.
Internal:			
Manhole/Chamber	Worn or Damaged Post, Baffles, Side of Chamber	Structure dissipating flow deteriorates to 1/2 of original size or any concentrated worn spot exceeding one square foot which would make structure unsound.	Structure replaced to design standards.
	Other Defects	See "Catch Basins" (No. 5).	See "Catch Basins" (No. 5).

## No. 8 – Typical Biofiltration Swale

Maintenance Component	Defect or Problem	Condition When Maintenance is Needed	Recommended Maintenance to Correct Problem
General	Sediment Accumulation on Grass	Sediment depth exceeds 2 inches.	Remove sediment deposits on grass treatment area of the bio-swale. When finished, swale should be level from side to side and drain freely toward outlet. There should be no areas of standing water once inflow has ceased.
	Standing Water	When water stands in the swale between storms and does not drain freely.	Any of the following may apply: remove sediment or trash blockages, improve grade from head to foot of swale, remove clogged check dams, add underdrains or convert to a wet biofiltration swale.
	Flow spreader	Flow spreader uneven or clogged so that flows are not uniformly distributed through entire swale width.	Level the spreader and clean so that flows are spread evenly over entire swale width.
	Constant Baseflow	When small quantities of water continually flow through the swale, even when it has been dry for weeks, and an eroded, muddy channel has formed in the swale bottom.	Add a low-flow pea-gravel drain the length of the swale or by-pass the baseflow around the swale.
	Poor Vegetation Coverage	When grass is sparse or bare or eroded patches occur in more than 10% of the swale bottom.	Determine why grass growth is poor and correct that condition. Re-plant with plugs of grass from the upper slope: plant in the swale bottom at 8-inch intervals. Or re-seed into loosened, fertile soil.
	Vegetation	When the grass becomes excessively tall (greater than 10-inches); when nuisance weeds and other vegetation starts to take over.	Mow vegetation or remove nuisance vegetation so that flow not impeded. Grass should be mowed to a height of 3 to 4 inches. Remove grass clippings.
	Excessive Shading	Grass growth is poor because sunlight does not reach swale.	If possible, trim back over-hanging limbs and remove brushy vegetation on adjacent slopes.
	Inlet/Outlet	Inlet/outlet areas clogged with sediment and/or debris.	Remove material so that there is no clogging or blockage in the inlet and outlet area.
	Trash and Debris Accumulation	Trash and debris accumulated in the bio-swale.	Remove trash and debris from bioswale.
	Erosion/Scouring	Eroded or scoured swale bottom due to flow channelization, or higher flows.	For ruts or bare areas less than 12 inches wide, repair the damaged area by filling with crushed gravel. If bare areas are large, generally greater than 12 inches wide, the swale should be re-graded and re-seeded. For smaller bare areas, overseed when bare spots are evident, or take plugs of grass from the upper slope and plant in the swale bottom at 8-inch intervals.



## No. 9 – Wet Biofiltration Swale

Maintenance Component	Defect or Problem	Condition When Maintenance is Needed	Recommended Maintenance to Correct Problem
General	Sediment Accumulation	Sediment depth exceeds 2-inches in 10% of the swale treatment area.	Remove sediment deposits in treatment area.
	Water Depth	Water not retained to a depth of about 4 inches during the wet season.	Build up or repair outlet berm so that water is retained in the wet swale.
	Wetland Vegetation	Vegetation becomes sparse and does not provide adequate filtration, OR vegetation is crowded out by very dense clumps of cattail, which do not allow water to flow through the clumps.	Determine cause of lack of vigor of vegetation and correct. Replant as needed. For excessive cattail growth, cut cattail shoots back and compost off-site. Note: normally wetland vegetation does not need to be harvested unless die-back is causing oxygen depletion in downstream waters.
	Inlet/Outlet	Inlet/outlet area clogged with sediment and/or debris.	Remove clogging or blockage in the inlet and outlet areas.
	Trash and Debris Accumulation	See "Detention Ponds" (No. 1).	Remove trash and debris from wet swale.
	Erosion/Scouring	Swale has eroded or scoured due to flow channelization, or higher flows.	Check design flows to assure swale is large enough to handle flows. By-pass excess flows or enlarge swale. Replant eroded areas with fibrous-rooted plants such as <i>Juncus effusus</i> (soft rush) in wet areas or snowberry ( <i>Symphoricarpos albus</i> ) in dryer areas.

## No. 10 – Filter Strips

Maintenance Component	Defect or Problem	Condition When Maintenance is Needed	Recommended Maintenance to Correct Problem
General	Sediment Accumulation on Grass	Sediment depth exceeds 2 inches.	Remove sediment deposits, re-level so slope is even and flows pass evenly through strip.
	Vegetation	When the grass becomes excessively tall (greater than 10-inches); when nuisance weeds and other vegetation starts to take over.	Mow grass, control nuisance vegetation, such that flow not impeded. Grass should be mowed to a height between 3-4 inches.
	Trash and Debris Accumulation	Trash and debris accumulated on the filter strip.	Remove trash and Debris from filter.
	Erosion/Scouring	Eroded or scoured areas due to flow channelization, or higher flows.	For ruts or bare areas less than 12 inches wide, repair the damaged area by filling with crushed gravel. The grass will creep in over the rock in time. If bare areas are large, generally greater than 12 inches wide, the filter strip should be re-graded and re-seeded. For smaller bare areas, overseed when bare spots are evident.
	Flow spreader	Flow spreader uneven or clogged so that flows are not uniformly distributed through entire filter width.	Level the spreader and clean so that flows are spread evenly over entire filter width.

## No. 11 – Wetponds

Maintenance Component	Defect	Condition When Maintenance is Needed	Results Expected When Maintenance is Performed
General	Water level	First cell is empty, doesn't hold water.	Line the first cell to maintain at least 4 feet of water. Although the second cell may drain, the first cell must remain full to control turbulence of the incoming flow and reduce sediment resuspension.
	Trash and Debris	Accumulation that exceeds 1 CF per 1000-SF of pond area.	Trash and debris removed from pond.
	Inlet/Outlet Pipe	Inlet/Outlet pipe clogged with sediment and/or debris material.	No clogging or blockage in the inlet and outlet piping.
	Sediment Accumulation in Pond Bottom	Sediment accumulations in pond bottom that exceeds the depth of sediment zone plus 6-inches, usually in the first cell.	Sediment removed from pond bottom.
	Oil Sheen on Water	Prevalent and visible oil sheen.	Oil removed from water using oil-absorbent pads or vacator truck. Source of oil located and corrected. If chronic low levels of oil persist, plant wetland plants such as <i>Juncus effusus</i> (soft rush) which can uptake small concentrations of oil.
	Erosion	Erosion of the pond's side slopes and/or scouring of the pond bottom, that exceeds 6-inches, or where continued erosion is prevalent.	Slopes stabilized using proper erosion control measures and repair methods.
	Settlement of Pond Dike/Berm	Any part of these components that has settled 4-inches or lower than the design elevation, or inspector determines dike/berm is unsound.	Dike/berm is repaired to specifications.
	Internal Berm	Berm dividing cells should be level.	Berm surface is leveled so that water flows evenly over entire length of berm.
Overflow Spillway	Rock is missing and soil is exposed at top of spillway or outside slope.	Rocks replaced to specifications.	

## No. 12 – Wetvaults

Maintenance Component	Defect	Condition When Maintenance is Needed	Results Expected When Maintenance is Performed
General	Trash/Debris Accumulation	Trash and debris accumulated in vault, pipe or inlet/outlet (includes floatables and non-floatables).	Remove trash and debris from vault.
	Sediment Accumulation in Vault	Sediment accumulation in vault bottom exceeds the depth of the sediment zone plus 6-inches.	Remove sediment from vault.
	Damaged Pipes	Inlet/outlet piping damaged or broken and in need of repair.	Pipe repaired and/or replaced.
	Access Cover Damaged/Not Working	Cover cannot be opened or removed, especially by one person.	Pipe repaired or replaced to proper working specifications.
	Ventilation	Ventilation area blocked or plugged.	Blocking material removed or cleared from ventilation area. A specified % of the vault surface area must provide ventilation to the vault interior (see design specifications).
	Vault Structure Damage - Includes Cracks in Walls Bottom, Damage to Frame and/or Top Slab	Maintenance/inspection personnel determine that the vault is not structurally sound.	Vault replaced or repairs made so that vault meets design specifications and is structurally sound.
		Cracks wider than 1/2-inch at the joint of any inlet/outlet pipe or evidence of soil particles entering through the cracks.	Vault repaired so that no cracks exist wider than 1/4-inch at the joint of the inlet/outlet pipe.
	Baffles	Baffles corroding, cracking, warping and/or showing signs of failure as determined by maintenance/inspection staff.	Baffles repaired or replaced to specifications.
Access Ladder Damage	Ladder is corroded or deteriorated, not functioning properly, not attached to structure wall, missing rungs, has cracks and/or misaligned. Confined space warning sign missing.	Ladder replaced or repaired to specifications, and is safe to use as determined by inspection personnel. Replace sign warning of confined space entry requirements. Ladder and entry notification complies with OSHA standards.	

### No. 13 – Sand Filters (above ground/open)

Maintenance Component	Defect	Condition When Maintenance is Needed	Results Expected When Maintenance is Performed
Above Ground (open sand filter)	Sediment Accumulation on top layer	Sediment depth exceeds 1/2-inch.	No sediment deposit on grass layer of sand filter that would impede permeability of the filter section.
	Trash and Debris Accumulations	Trash and debris accumulated on sand filter bed.	Trash and debris removed from sand filter bed.
	Sediment/ Debris in Clean-Outs	When the clean-outs become full or partially plugged with sediment and/or debris.	Sediment removed from clean-outs.
	Sand Filter Media	Drawdown of water through the sand filter media takes longer than 24-hours, and/or flow through the overflow pipes occurs frequently.	Top several inches of sand are scraped. May require replacement of entire sand filter depth depending on extent of plugging (a sieve analysis is helpful to determine if the lower sand has too high a proportion of fine material).
	Prolonged Flows	Sand is saturated for prolonged periods of time (several weeks) and does not dry out between storms due to continuous base flow or prolonged flows from detention facilities.	Low, continuous flows are limited to a small portion of the facility by using a low wooden divider or slightly depressed sand surface.
	Short Circuiting	When flows become concentrated over one section of the sand filter rather than dispersed.	Flow and percolation of water through sand filter is uniform and dispersed across the entire filter area.
	Erosion Damage to Slopes	Erosion over 2-inches deep where cause of damage is prevalent or potential for continued erosion is evident.	Slopes stabilized using proper erosion control measures.
	Rock Pad Missing or Out of Place	Soil beneath the rock is visible.	Rock pad replaced or rebuilt to design specifications.
	Flow Spreader	Flow spreader uneven or clogged so that flows are not uniformly distributed across sand filter.	Spreader leveled and cleaned so that flows are spread evenly over sand filter.
	Damaged Pipes	Any part of the piping that is crushed or deformed more than 20% or any other failure to the piping.	Pipe repaired or replaced.

#### No. 14 –Sand Filters (below ground/enclosed)

Maintenance Component	Defect	Condition When Maintenance is Needed	Results Expected When Maintenance is Performed
Below Ground Vault.	Sediment Accumulation on Sand Media Section	Sediment depth exceeds 1/2-inch.	No sediment deposits on sand filter section that which would impede permeability of the filter section.
	Sediment Accumulation in Pre-Settling Portion of Vault	Sediment accumulation in vault bottom exceeds the depth of the sediment zone plus 6-inches.	No sediment deposits in first chamber of vault.
	Trash/Debris Accumulation	Trash and debris accumulated in vault, or pipe inlet/outlet, floatables and non-floatables.	Trash and debris removed from vault and inlet/outlet piping.
	Sediment in Drain Pipes/Cleanouts	When drain pipes, cleanouts become full with sediment and/or debris.	Sediment and debris removed.
	Short Circuiting	When seepage/flow occurs along the vault walls and corners. Sand eroding near inflow area.	Sand filter media section re-laid and compacted along perimeter of vault to form a semi-seal. Erosion protection added to dissipate force of incoming flow and curtail erosion.
	Damaged Pipes	Inlet or outlet piping damaged or broken and in need of repair.	Pipe repaired and/or replaced.
	Access Cover Damaged/Not Working	Cover cannot be opened, corrosion/deformation of cover. Maintenance person cannot remove cover using normal lifting pressure.	Cover repaired to proper working specifications or replaced.
	Ventilation	Ventilation area blocked or plugged	Blocking material removed or cleared from ventilation area. A specified % of the vault surface area must provide ventilation to the vault interior (see design specifications).
	Vault Structure Damaged; Includes Cracks in Walls, Bottom, Damage to Frame and/or Top Slab.	Cracks wider than 1/2-inch or evidence of soil particles entering the structure through the cracks, or maintenance/inspection personnel determine that the vault is not structurally sound.	Vault replaced or repairs made so that vault meets design specifications and is structurally sound.
Cracks wider than 1/2-inch at the joint of any inlet/outlet pipe or evidence of soil particles entering through the cracks.		Vault repaired so that no cracks exist wider than 1/4-inch at the joint of the inlet/outlet pipe.	
Baffles/Internal walls	Baffles or walls corroding, cracking, warping and/or showing signs of failure as determined by maintenance/inspection person.	Baffles repaired or replaced to specifications.	
Access Ladder Damaged	Ladder is corroded or deteriorated, not functioning properly, not securely attached to structure wall, missing rungs, cracks, and misaligned.	Ladder replaced or repaired to specifications, and is safe to use as determined by inspection personnel.	

**No. 15 – Stormfilter™ (leaf compost filter)**

Maintenance Component	Defect	Condition When Maintenance is Needed	Results Expected When Maintenance is Performed
Below Ground Vault	Sediment Accumulation on Media.	Sediment depth exceeds 0.25-inches.	No sediment deposits which would impede permeability of the compost media.
	Sediment Accumulation in Vault	Sediment depth exceeds 6-inches in first chamber.	No sediment deposits in vault bottom of first chamber.
	Trash/Debris Accumulation	Trash and debris accumulated on compost filter bed.	Trash and debris removed from the compost filter bed.
	Sediment in Drain Pipes/Clean-Outs	When drain pipes, clean-outs, become full with sediment and/or debris.	Sediment and debris removed.
	Damaged Pipes	Any part of the pipes that are crushed or damaged due to corrosion and/or settlement.	Pipe repaired and/or replaced.
	Access Cover Damaged/Not Working	Cover cannot be opened; one person cannot open the cover using normal lifting pressure, corrosion/deformation of cover.	Cover repaired to proper working specifications or replaced.
	Vault Structure Includes Cracks in Wall, Bottom, Damage to Frame and/or Top Slab	Cracks wider than 1/2-inch or evidence of soil particles entering the structure through the cracks, or maintenance/inspection personnel determine that the vault is not structurally sound.	Vault replaced or repairs made so that vault meets design specifications and is structurally sound.
		Cracks wider than 1/2-inch at the joint of any inlet/outlet pipe or evidence of soil particles entering through the cracks.	Vault repaired so that no cracks exist wider than 1/4-inch at the joint of the inlet/outlet pipe.
	Baffles	Baffles corroding, cracking warping, and/or showing signs of failure as determined by maintenance/inspection person.	Baffles repaired or replaced to specifications.
Access Ladder Damaged	Ladder is corroded or deteriorated, not functioning properly, not securely attached to structure wall, missing rungs, cracks, and misaligned.	Ladder replaced or repaired and meets specifications, and is safe to use as determined by inspection personnel.	
Below Ground Cartridge Type	Compost Media	Drawdown of water through the media takes longer than 1 hour, and/or overflow occurs frequently.	Media cartridges replaced.
	Short Circuiting	Flows do not properly enter filter cartridges.	Filter cartridges replaced.

## No. 16 – Baffle Oil/Water Separators (API Type)

Maintenance Component	Defect	Condition When Maintenance is Needed	Results Expected When Maintenance is Performed
General	Monitoring	Inspection of discharge water for obvious signs of poor water quality.	Effluent discharge from vault should be clear with out thick visible sheen.
	Sediment Accumulation	Sediment depth in bottom of vault exceeds 6-inches in depth.	No sediment deposits on vault bottom that would impede flow through the vault and reduce separation efficiency.
	Trash and Debris Accumulation	Trash and debris accumulation in vault, or pipe inlet/outlet, floatables and non-floatables.	Trash and debris removed from vault, and inlet/outlet piping.
	Oil Accumulation	Oil accumulations that exceed 1-inch, at the surface of the water.	Extract oil from vault by vactoring. Disposal in accordance with state and local rules and regulations.
	Damaged Pipes	Inlet or outlet piping damaged or broken and in need of repair.	Pipe repaired or replaced.
	Access Cover Damaged/Not Working	Cover cannot be opened, corrosion/deformation of cover.	Cover repaired to proper working specifications or replaced.
	Vault Structure Damage - Includes Cracks in Walls Bottom, Damage to Frame and/or Top Slab	See "Catch Basins" (No. 5)	Vault replaced or repairs made so that vault meets design specifications and is structurally sound.
		Cracks wider than 1/2-inch at the joint of any inlet/outlet pipe or evidence of soil particles entering through the cracks.	Vault repaired so that no cracks exist wider than 1/4-inch at the joint of the inlet/outlet pipe.
	Baffles	Baffles corroding, cracking, warping and/or showing signs of failure as determined by maintenance/inspection person.	Baffles repaired or replaced to specifications.
Access Ladder Damaged	Ladder is corroded or deteriorated, not functioning properly, not securely attached to structure wall, missing rungs, cracks, and misaligned.	Ladder replaced or repaired and meets specifications, and is safe to use as determined by inspection personnel.	



## No. 17 – Coalescing Plate Oil/Water Separators

Maintenance Component	Defect	Condition When Maintenance is Needed	Results Expected When Maintenance is Performed	
General	Monitoring	Inspection of discharge water for obvious signs of poor water quality.	Effluent discharge from vault should be clear with no thick visible sheen.	
	Sediment Accumulation	Sediment depth in bottom of vault exceeds 6-inches in depth and/or visible signs of sediment on plates.	No sediment deposits on vault bottom and plate media, which would impede flow through the vault and reduce separation efficiency.	
	Trash and Debris Accumulation	Trash and debris accumulated in vault, or pipe inlet/outlet, floatables and non-floatables.	Trash and debris removed from vault, and inlet/outlet piping.	
	Oil Accumulation	Oil accumulation that exceeds 1-inch at the water surface.	Oil is extracted from vault using vacuoring methods. Coalescing plates are cleaned by thoroughly rinsing and flushing. Should be no visible oil depth on water.	
	Damaged Coalescing Plates	Plate media broken, deformed, cracked and/or showing signs of failure.	A portion of the media pack or the entire plate pack is replaced depending on severity of failure.	
	Damaged Pipes	Inlet or outlet piping damaged or broken and in need of repair.	Pipe repaired and or replaced.	
	Baffles	Baffles corroding, cracking, warping and/or showing signs of failure as determined by maintenance/inspection person.	Baffles repaired or replaced to specifications.	
	Vault Structure Damage - Includes Cracks in Walls, Bottom, Damage to Frame and/or Top Slab		Cracks wider than 1/2-inch or evidence of soil particles entering the structure through the cracks, or maintenance/inspection personnel determine that the vault is not structurally sound.	Vault replaced or repairs made so that vault meets design specifications and is structurally sound.
			Cracks wider than 1/2-inch at the joint of any inlet/outlet pipe or evidence of soil particles entering through the cracks.	Vault repaired so that no cracks exist wider than 1/4-inch at the joint of the inlet/outlet pipe.
Access Ladder Damaged	Ladder is corroded or deteriorated, not functioning properly, not securely attached to structure wall, missing rungs, cracks, and misaligned.	Ladder replaced or repaired and meets specifications, and is safe to use as determined by inspection personnel.		

## No. 18 – Catchbasin Inserts

Maintenance Component	Defect	Conditions When Maintenance is Needed	Results Expected When Maintenance is Performed
General	Sediment Accumulation	When sediment forms a cap over the insert media of the insert and/or unit.	No sediment cap on the insert media and its unit.
	Trash and Debris Accumulation	Trash and debris accumulates on insert unit creating a blockage/restriction.	Trash and debris removed from insert unit. Runoff freely flows into catch basin.
	Media Insert Not Removing Oil	Effluent water from media insert has a visible sheen.	Effluent water from media insert is free of oils and has no visible sheen.
	Media Insert Water Saturated	Catch basin insert is saturated with water and no longer has the capacity to absorb.	Remove and replace media insert
	Media Insert-Oil Saturated	Media oil saturated due to petroleum spill that drains into catch basin.	Remove and replace media insert.
	Media Insert Use Beyond Normal Product Life	Media has been used beyond the typical average life of media insert product.	Remove and replace media at regular intervals, depending on insert product.

<b>Table 4.1 Ratio of 91% Flow Rate to 2-Year Frequency vs. Effective Impervious Area</b>			
<b>15 Minutes data</b>		<b>Hourly data</b>	
<b>EIA</b>	<b>Ratio</b>	<b>EIA</b>	<b>Ratio</b>
10%	0.19	10%	0.19
15%	0.20	15%	0.20
20%	0.22	20%	0.20
25%	0.23	25%	0.21
30%	0.25	30%	0.22
35%	0.26	35%	0.23
40%	0.28	40%	0.24
45%	0.30	45%	0.25
50%	0.31	50%	0.26
54%	0.33	54%	0.27
60%	0.34	60%	0.28
65%	0.36	65%	0.28
70%	0.37	70%	0.29
75%	0.38	75%	0.30
80%	0.39	80%	0.30
85%	0.40	85%	0.31
90%	0.41	90%	0.31
95%	0.42	95%	0.32
100%	0.43	100%	0.32

<b>Table 4.2 Treatment Facility Placement in Relation to Detention</b>		
<b>Water Quality Facility</b>	<b>Preceding Detention</b>	<b>Following Detention</b>
Basic biofiltration swale (Chapter 9)	OK	OK. Prolonged flows may reduce grass survival. Consider wet biofiltration swale
Wet biofiltration swale (Chapter 9)	OK	OK
Filter strip (Chapter 9)	OK	No—must be installed before flows concentrate.
Basic or large wetpond (Chapter 10)	OK	OK—less water level fluctuation in ponds downstream of detention may improve aesthetic qualities and performance.
Basic or large combined detention and wetpond (Chapter 10)	Not applicable	Not applicable
Wetvault (Chapter 10)	OK	OK
Basic or large sand filter or sand filter vault (Chapter 8)	OK, but presettling and control of floatables needed	OK—sand filters downstream of detention facilities may require field adjustments if prolonged flows cause sand saturation and interfere with phosphorus removal.
Storm water treatment wetland/pond (Chapter 10)	OK	OK—less water level fluctuation and better plant diversity are possible if the storm water wetland is located downstream of the detention facility.

<b>WQ Facility</b>	<b>Area to be Lined</b>	<b>Type of Liner Recommended</b>
Presettling basin	Bottom and sides	Low permeability liner or Treatment liner (If the basin will intercept the seasonal high ground water table, a treatment liner is recommended.)
Wetpond	First cell: bottom and sides to WQ design water surface -----	Low permeability liner or Treatment liner (If the wet pond will intercept the seasonal high ground water table, a treatment liner is recommended.) -----
	Second cell: bottom and sides to WQ design water surface	Treatment liner
Combined detention/WQ facility	First cell: bottom and sides to WQ design water surface -----	Low permeability liner or Treatment liner (If the facility will intercept the seasonal high ground water table a treatment liner is recommended.) -----
	Second cell: bottom and sides to WQ design water surface	Treatment liner
Storm water wetland	Bottom and sides, both cells	Low permeability liner (If the facility will intercept the seasonal high ground water table, a treatment liner is recommended.)
Sand filtration basin	Basin sides only	Treatment liner
Sand filter vault	Not applicable	No liner needed
Linear sand filter	Not applicable if in vault Bottom and sides of presettling cell if not in vault	No liner needed Low permeability or treatment liner
Media filter (in vault)	Not applicable	No liner needed
Wet vault	Not applicable	No liner needed

<b>Sieve Size</b>	<b>Percent Passing</b>
6-inch	100
4-inch	90
#4	70 - 100
#200	20

Table 4.5 Rock Protection at Outfalls					
Discharge Velocity at Design Flow in feet per second (fps)	Required Protection Minimum Dimensions				
	Type	Thickness	Width	Length	Height
0 – 5	Rock lining <sup>(1)</sup>	1 foot	Diameter + 6 feet	8 feet or 4 x diameter, whichever is greater	Crown + 1 foot
5 <sup>+</sup> - 10	Riprap <sup>(2)</sup>	2 feet	Diameter + 6 feet or 3 x diameter, whichever is greater	12 feet or 4 x diameter, whichever is greater	Crown + 1 foot
10 <sup>+</sup> - 20	Gabion outfall	As required	As required	As required	Crown + 1 foot
20 <sup>+</sup>	Engineered energy dissipater required				

Footnotes:

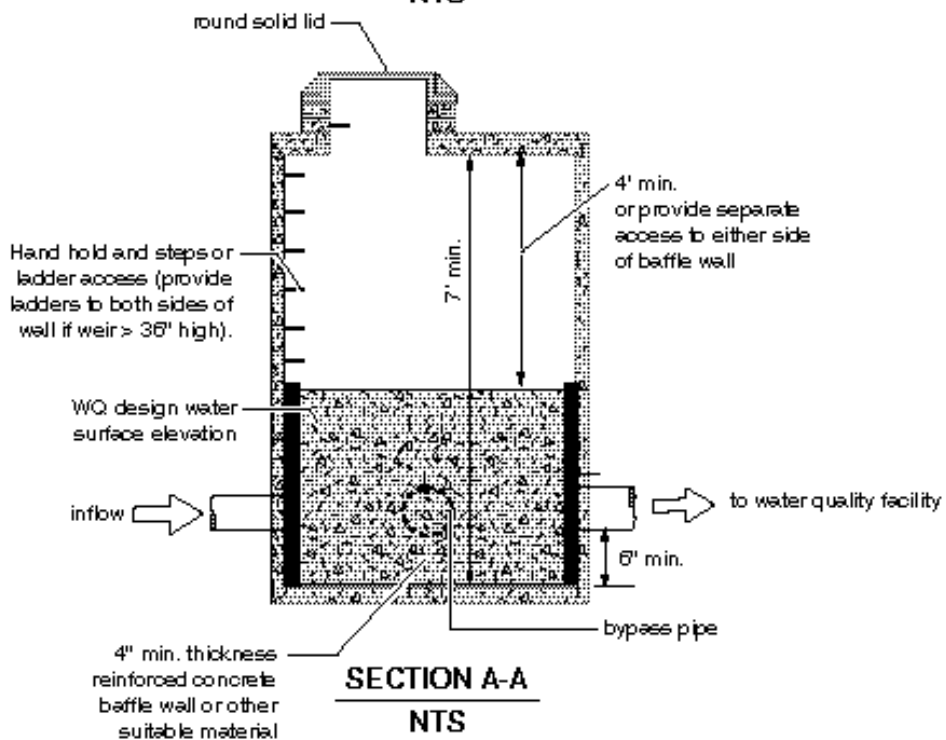
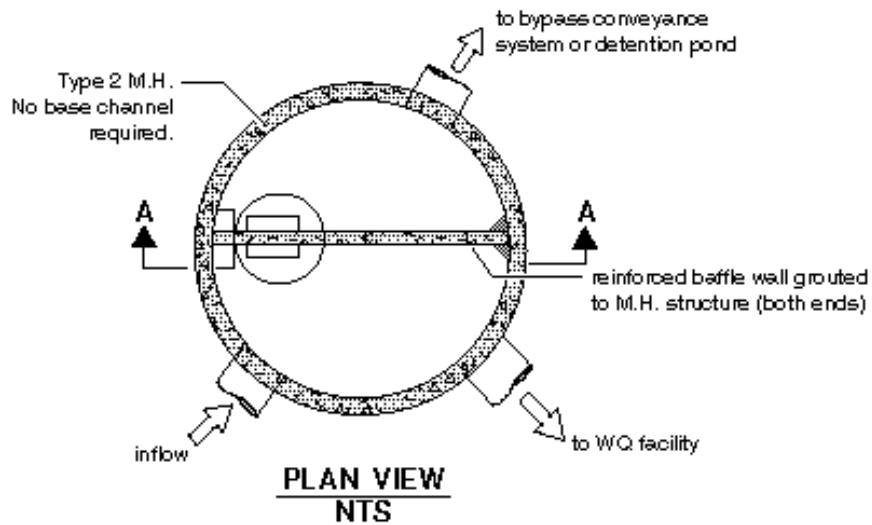
(1) **Rock lining** shall be quarry spalls with gradation as follows:

Passing 8-inch square sieve: 100%  
 Passing 3-inch square sieve: 40 to 60% maximum  
 Passing ¾-inch square sieve: 0 to 10% maximum

(2) **Riprap** shall be reasonably well graded with gradation as follows:

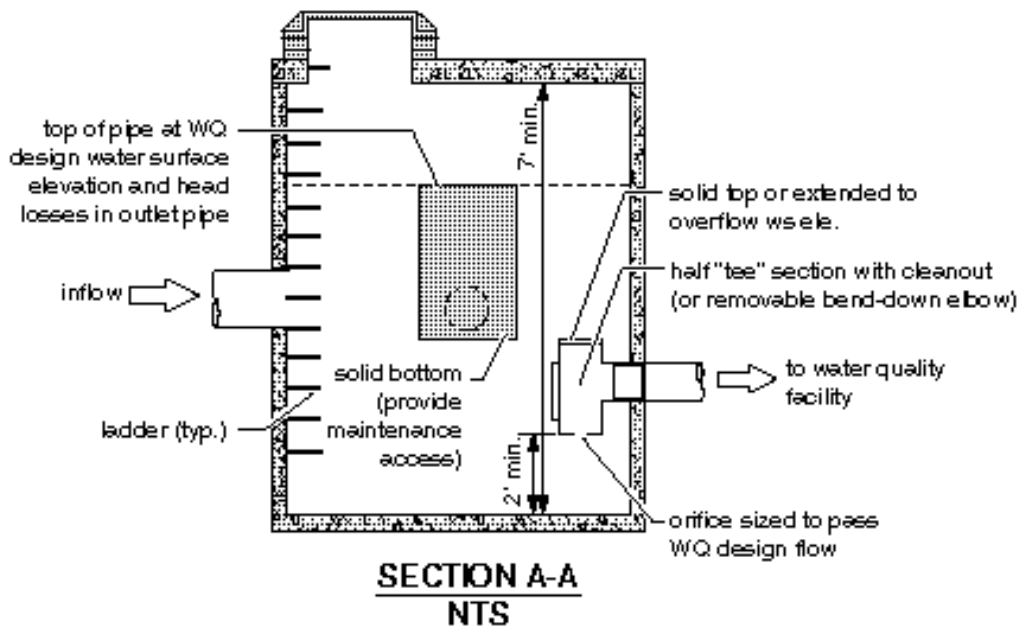
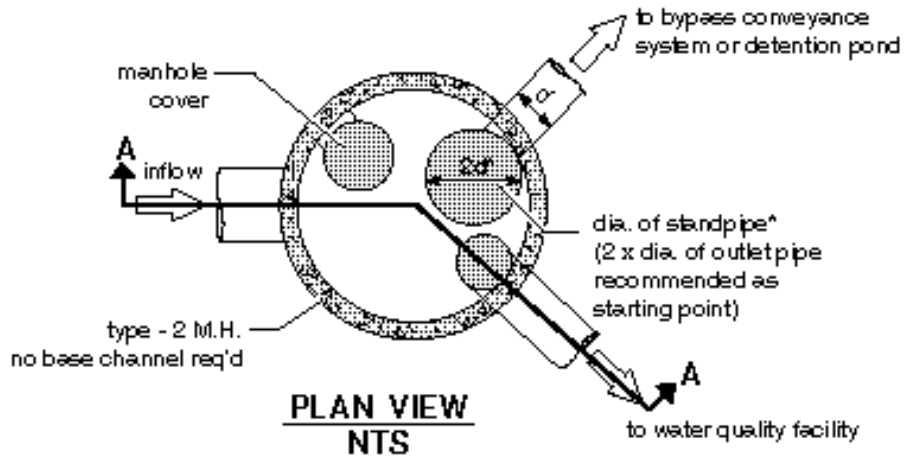
Maximum stone size: 24 inches (nominal diameter)  
 Median stone size: 16 inches  
 Minimum stone size: 4 inches

*Note: Riprap sizing governed by side slopes on outlet channel is assumed to be approximately 3:1.*



Note: The water quality discharge pipe may require an orifice plate be installed on the outlet to control the height of the design water surface (weir height). The design water surface should be set to provide a minimum headwater/diameter ratio of 2.0 on the outlet pipe.

**Figure 4-1 Flow Splitter, Option A**

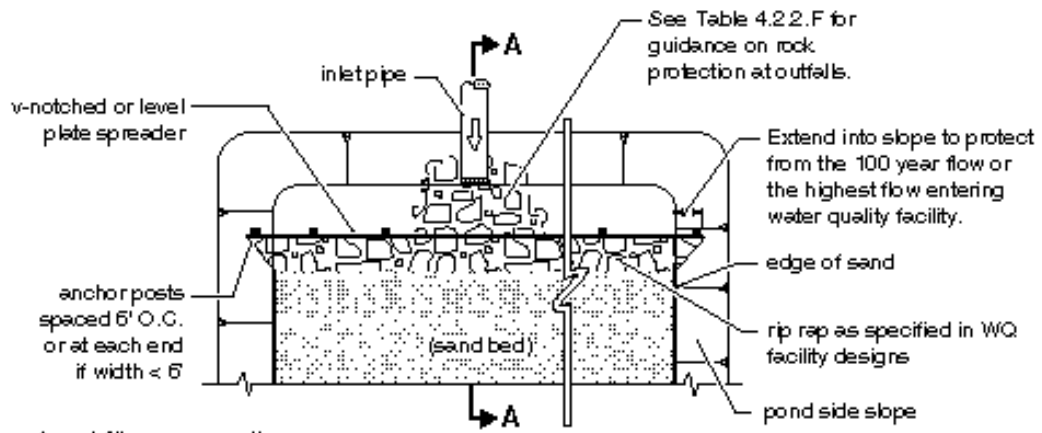


\* **NOTE:** Diameter (d) of standpipe should be large enough to minimize head above W.Q. design W.S. and to keep W.Q. design flows from increasing more than 10% during 100-year flows.

**Figure 4-2 Flow Splitter, Option B**

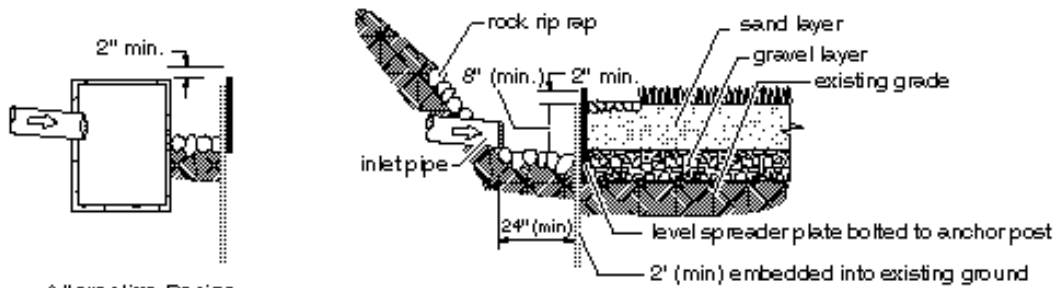


Example of anchored plate used with a sand filter\* (may also be used with other water quality facilities).



\*sand filter may use other spreading options

**PLAN VIEW**  
NTS

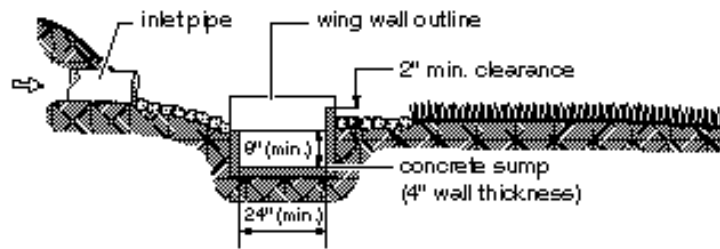
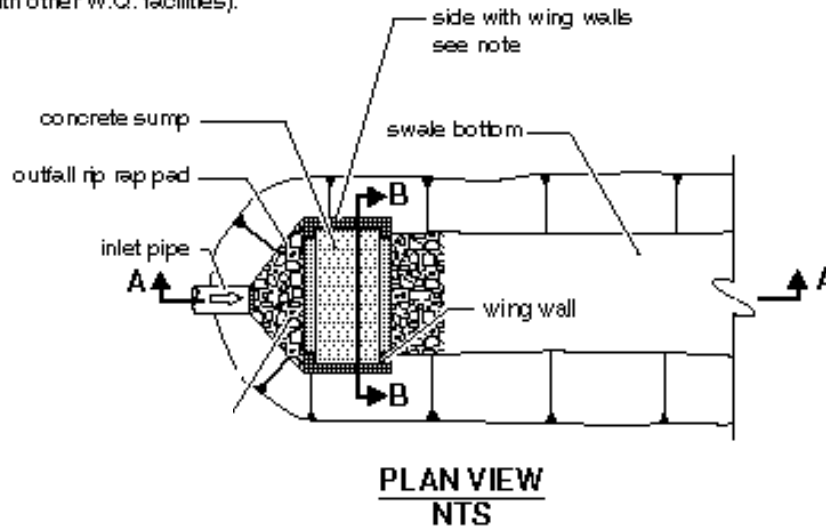


**Alternative Design**  
Catch basin recommended for higher flow situations (generally for inflow velocities of 5 f/s or greater for 100 year storm).

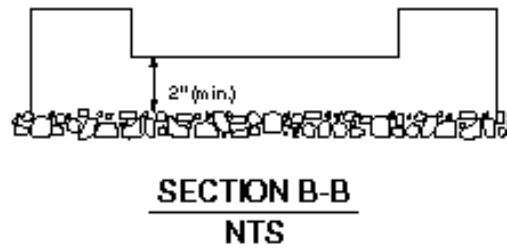
**SECTION A-A**  
NTS

**Figure 4-3 Flow Spreader Option A: Anchored Plate**

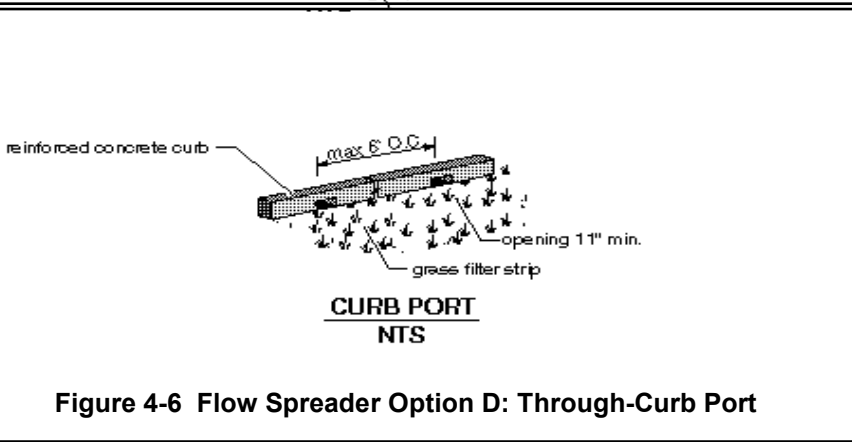
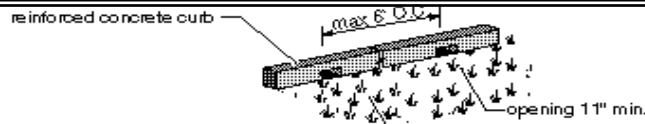
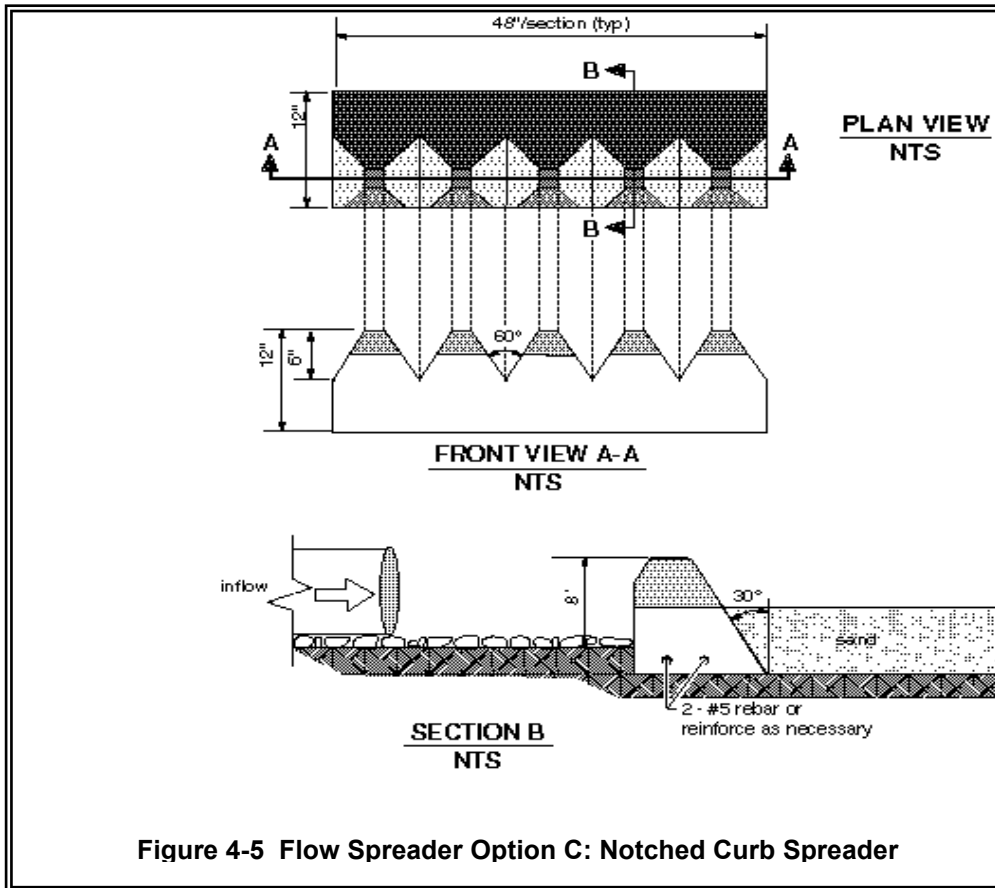
Example of a concrete sump flow spreader used with a biofiltration swale (may be used with other W.Q. facilities).



Note: Extend sides into slope. Height of side wall and wing walls must be sufficient to handle the 100 year flow or the highest flow entering the facility.



**Figure 4-4 Flow Spreader Option B: Concrete Sump Box**





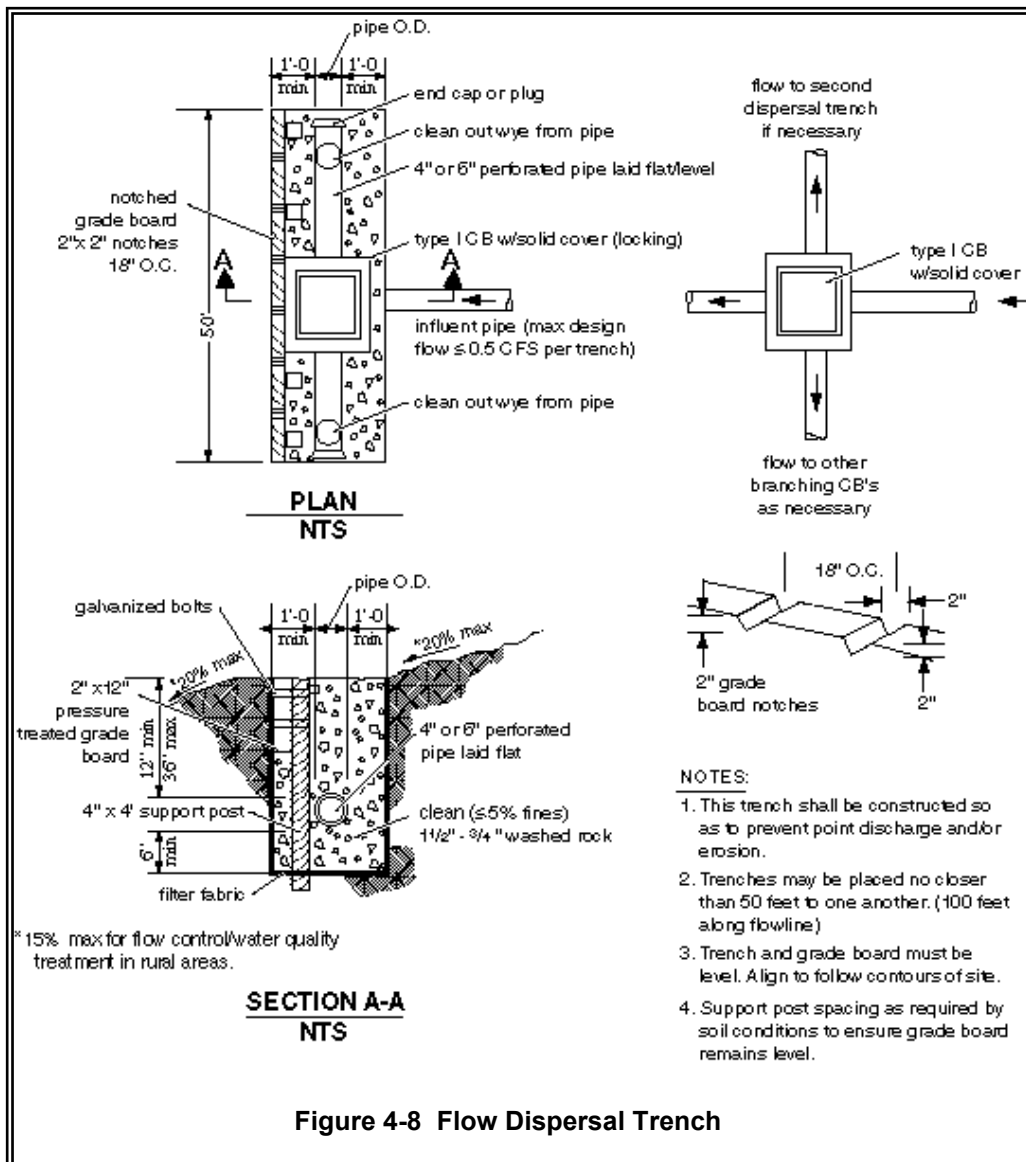
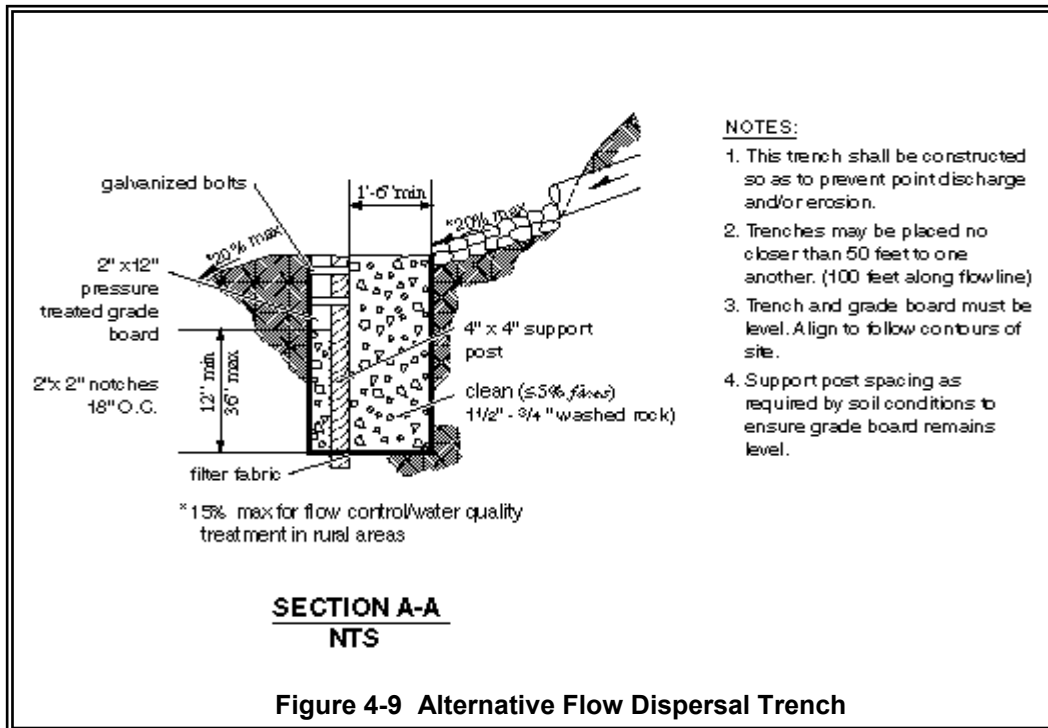
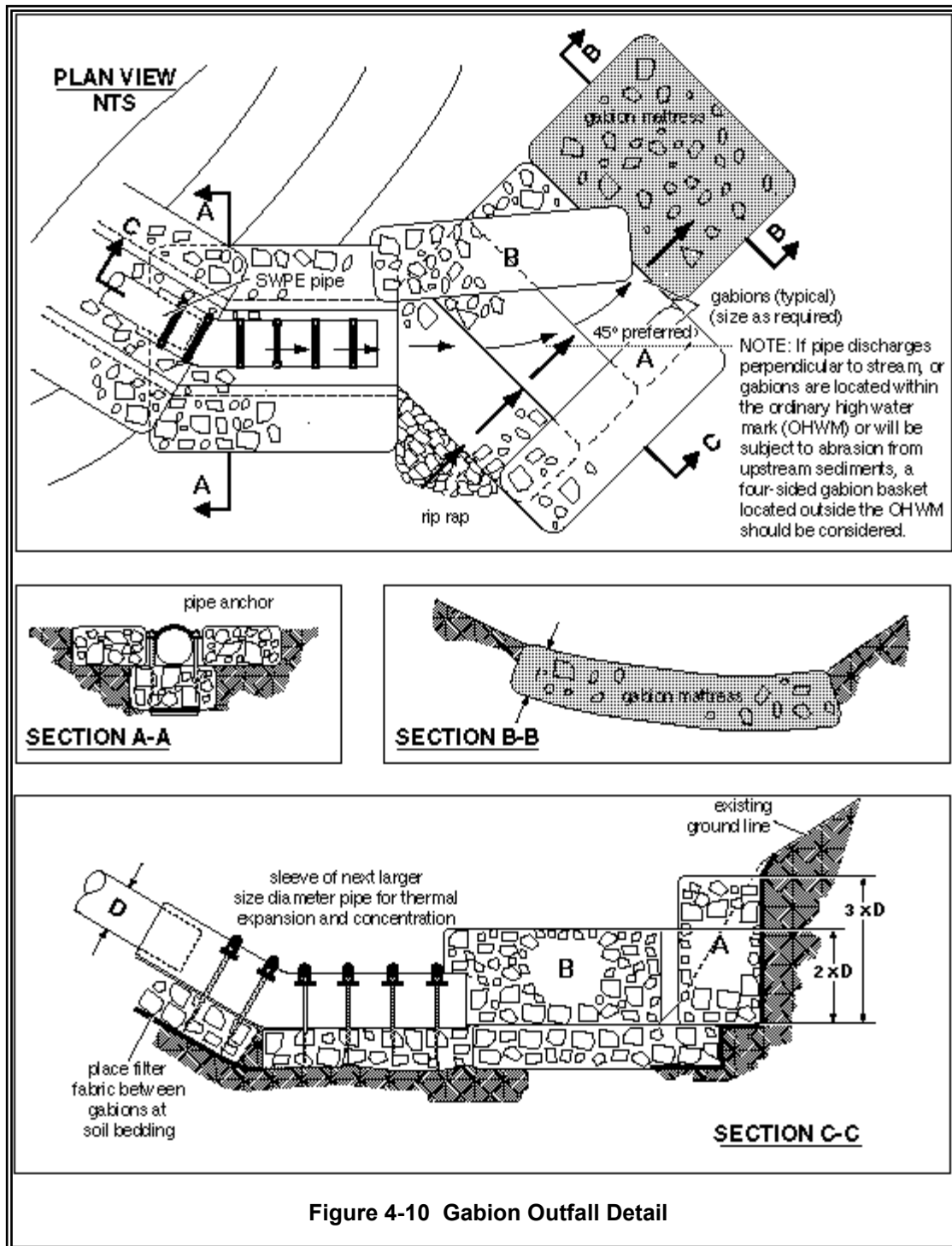
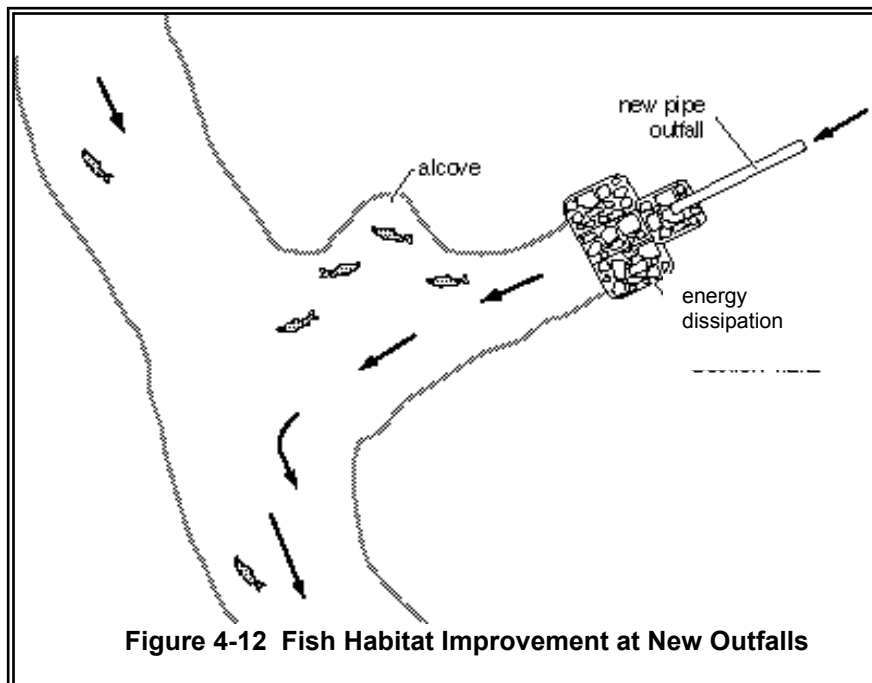
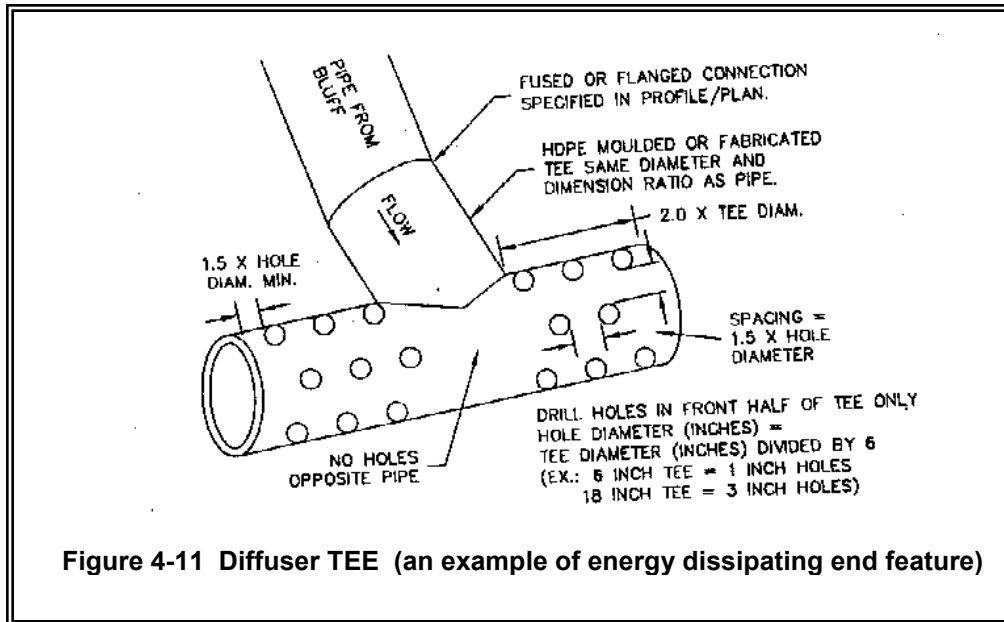


Figure 4-8 Flow Dispersal Trench









# Chapter 5 - On-Site Storm Water Management

---

*Note: Figures 5.1 through 5.5 are courtesy of King County, Figures 5.6 and 5.7 are from Ecology's 1992 Manual, and Figures 5.8 through 5.14 are courtesy of Washington Concrete and Aggregate Association.*

## 5.1 Purpose

This Chapter presents the methods for analysis and design of on-site storm water management Best Management Practices (BMPs). Many of these BMPs, although being used elsewhere, are new locally. Efforts are underway to further develop these "low impact development" concepts in Western Washington. Ecology will update these BMPs when local standards are established. The City will update these BMPs as information is made available by Ecology.

Design procedures and requirements for storm water management BMPs meeting Minimum Requirement #7, Flow Control, are not found in this Volume but are found in Volume III.

## 5.2 Application

The On-Site Storm Water Management BMPs presented in this Chapter have application to treatment situations specified in Volume V, Chapter 3.

On-site BMPs focus on minimization of impervious surface area, the use of infiltration, and dispersion through on-site vegetation for storm water runoff flow control and treatment.

Most of the BMPs serve to control runoff flow rate as well as to provide runoff treatment. Non-pollution generating surfaces, such as rooftops and patios, may also use the infiltration BMPs contained in Volume III, Section 3.1, which provide flow control only. Pollution generating surfaces, such as driveways, small parking lots, and landscaping, must use on-site BMPs to provide some water quality treatment.

## 5.3 Best Management Practices for On-Site Storm Water Management

Included are the following specific On-Site Storm Water Management BMPs discussed in this Chapter:

### Section 5.3.1 - Dispersion and Soil Quality BMPs

- BMP T5.10 Downspout Dispersion
- BMP T5.11 Concentrated Flow Dispersion
- BMP T5.12 Sheet Flow Dispersion
- BMP T5.13 Post-Construction Soil Quality and Depth

### Section 5.3.2 - Site Design BMPs

- BMP T5.20 Preserving Natural Vegetation
- BMP T5.21 Better Site Design

### Section 5.3.3 – Other Practices

- BMP T5.30 Full Dispersion
- BMP T5.31 Vegetated Rooftops
- BMP T5.32 Cisterns
- BMP T5.33 Concave Vegetated Surface
- BMP T5.34 Multiple Small Basins
- BMP T5.35 Engineered Soil/Landscape Systems
- BMP T5.36 Soil Compaction Protection and Mitigation

### Section 5.3.4 - Permeable/Porous Pavements

- BMP T5.40 Porous Pavement
- BMP T5.41 Porous Pavers
- BMP T5.42 Permeable Interlocking Concrete Pavement

Projects shall employ these BMPs to infiltrate, disperse, and retain storm water runoff on site to the maximum extent practicable without causing flooding or erosion impacts. **Infiltration and dispersion systems shall have pre-approval by the City with regard to appropriateness for the project site.** Sites that can fully infiltrate (see Volume III, Chapter 3) or fully disperse (see BMP T5.30) are not required to provide runoff treatment or flow control facilities. Full dispersion credit is limited to sites with a maximum of 10% impervious area that is dispersed through 65% of the site maintained in natural vegetation.

Impervious surfaces that are not fully dispersed should be partially dispersed to the maximum extent practicable and then hydrologically modeled. If the model predicts that there will be a 0.1 cfs or greater increase in the 100-year return frequency flow, or if certain thresholds of impervious surfaces or converted pervious surfaces are exceeded within a threshold discharge area (see Volume I, Table 3.2), then a flow control facility is required. Also, a treatment facility is required if the thresholds in Table 3.1 of Volume I are exceeded. Residential roofs that are dispersed through at least 50 feet of native vegetation may be modeled as grass. Other impervious surfaces that are partially dispersed will not be given flow credit. Modular grid pavements will be allowed a flow credit. Porous concrete and asphalt will not be allowed a flow credit at this time due to the uncertainty of long-term viability.

### **5.3.1 Dispersion and Soil Quality BMPs**

The following BMPs pertain to dispersion and soil quality applications.

#### **BMP T5.10 Downspout Dispersion**

##### ***Purpose and Definition***

*Downspout dispersion BMPs* are splashblocks or gravel-filled trenches that serve to spread roof runoff over vegetated pervious areas. Dispersion attenuates peak flows by slowing entry of the runoff into the conveyance system, allows for some infiltration, and provides some water quality benefits. This information is repeated in Volume III.

##### ***Applications and Limitations***

- Downspout dispersion may be used on all subdivision single-family lots which meet one of the following criteria (with City pre-approval):
  1. Lots greater than or equal to 22,000 square feet where downspout infiltration is not being provided according to the requirements in Volume III, Chapter 3.
  2. Lots smaller than 22,000 square feet where soils are not suitable for downspout infiltration as determined in Volume III, Chapter 3 and where the design criteria below can be met.
- All other projects required to apply Roof Downspout BMPs must provide downspout dispersion if downspout infiltration is not feasible or applicable as determined in Volume III, Chapter 3, and if the design criteria below can be met.

##### ***General Design Guidelines***

- Dispersion trenches designed as shown in the Figures 5.1 and 5.2 shall be used for all downspout dispersion applications except where splashblocks are allowed below. See Figure 5.3 for a typical splashblock.
- Splashblocks may be used for downspouts discharging to a vegetated flowpath at least 50 feet in length as measured from the downspout to the downstream property line, structure, sensitive steep slope, stream, wetland, or other impervious surface. Sensitive area buffers may count toward flowpath lengths. The vegetated flowpath must be covered with well-established lawn or pasture, landscaping with well-established groundcover, or native vegetation with natural groundcover. The groundcover shall be dense enough to help disperse and infiltrate flows and to prevent erosion.
- If the vegetated flowpath (measured as defined above) is less than 25 feet on a subdivision single-family lot, a perforated stub-out connection may be used in lieu of downspout dispersion (see Volume III, Chapter 3). A perforated stub-out may also be used where implementation of downspout dispersion might cause erosion or flooding problems, either on site or on adjacent lots. This provision might be appropriate, for example, for lots constructed on steep hills

where downspout discharge could be cumulative and might pose a potential hazard for lower lying lots, or where dispersed flows could create problems for adjacent offsite lots. This provision does not apply to situations where lots are flat and onsite downspout dispersal would result in saturated yards.

*Note: For all other types of projects, the use of a perforated stub-out in lieu of downspout dispersion shall be as determined by the City.*

#### **Additional Design Criteria For Dispersion Trenches**

- A vegetated flowpath of at least 25 feet in length must be maintained between the outlet of the trench and any property line, structure, stream, wetland, or impervious surface. A vegetated flowpath of at least 50 feet in length must be maintained between the outlet of the trench and any steep slope. Sensitive area buffers may count towards flowpath lengths.
- Trenches serving up to 700 square feet of roof area may be simple 10-foot-long by 2-foot wide gravel filled trenches as shown on Figure 5-1. For roof areas larger than 700 square feet, a dispersion trench with notched grade board as shown in Figure 5-2 may be used as approved by the City. The total length of this design must provide at least 10 feet of trench per 700 square feet of roof area and not exceed 50 feet.
- All dispersion systems shall be at least 10 feet from any structure. If necessary, setbacks shall be increased from the minimum 10 feet in order to maintain a 1:1 side slope for future excavation and maintenance.
- All dispersion systems shall be placed at least 5 feet from any property line. If necessary, setbacks shall be increased from the minimum 5 feet in order to maintain a 1:1 side slope for future excavation and maintenance.
- Dispersion systems shall be setback from sensitive areas, steep slopes, landslide hazard areas, and erosion hazard areas as governed by the Tacoma Municipal Code.
- No erosion or flooding of downstream properties shall result.
- Runoff discharged towards landslide hazard areas must be evaluated by a geotechnical engineer or qualified geologist. The discharge point shall not be placed on or above slopes greater than 20% or above erosion hazard areas without evaluation by a geotechnical engineer or qualified geologist and City approval.
- For sites with septic systems, the discharge point must be downgradient of the drainfield primary and reserve areas. This requirement can be waived by the City's permit review staff if site topography will clearly prohibit flows from intersecting the drainfield.

### **Additional Design Criteria For Splashblocks**

In general, if the ground is sloped away from the foundation, and there is adequate vegetation and area for effective dispersion, splashblocks will adequately disperse storm runoff. If the ground is fairly level, if the structure includes a basement, or if foundation drains are proposed, splashblocks with downspout extensions may be a better choice because the discharge point is moved away from the foundation. Downspout extensions can include piping to a splashblock/discharge point a considerable distance from the downspout, as long as the runoff can travel through a well-vegetated area as described below.

The following conditions must be met to use splashblocks:

- A vegetated flowpath of at least 50 feet must be maintained between the discharge point and any property line, structure, steep slope, stream, wetland, lake, or other impervious surface. Sensitive area buffers may count toward flowpath lengths.
- Flows shall not be directed onto sidewalks.
- A maximum of 700 square feet of roof area may drain to each splashblock.
- A splashblock or a pad of crushed rock (2 feet wide by 3 feet long by 6 inches deep) shall be placed at each downspout discharge point.
- No erosion or flooding of downstream properties may result.
- Runoff discharged towards landslide hazard areas must be evaluated by a geotechnical engineer or qualified geologist. Splashblocks may not be placed on or above slopes greater than 20% or above erosion hazard areas without evaluation by a geotechnical engineer or qualified geologist and approval by the City.
- For sites with septic systems, the discharge point must be downslope of the primary and reserve drainfield areas. This requirement may be waived by the City if site topography clearly prohibits flows from intersecting the drainfield or where site conditions indicate that this is unnecessary (see Volume III, Chapter 3).

## **BMP T5.11 Concentrated Flow Dispersion**

### ***Purpose and Definition***

Dispersion of concentrated flows from driveways or other pavement through a vegetated pervious area attenuates peak flows by slowing entry of the runoff into the conveyance system, allows for some infiltration, and provides some water quality benefits (see Figure 5.4).

### ***Applications and Limitations***

- Any situation where concentrated flow can be dispersed through vegetation.
- Dispersion for driveways will generally only be effective for single-family residences on large lots and in rural short plats. Lots proposed by short plats in urban areas will generally be too small to provide effective dispersion of driveway runoff.
- Figure 5.4 shows two possible ways of spreading flows from steep driveways.

### ***Design Guidelines***

- A vegetated flowpath of at least 50 feet should be maintained between the discharge point and any property line, structure, steep slope, stream, lake, wetland, lake, or other impervious surface.
- A maximum of 700 square feet of impervious area may drain to each dispersion BMP.
- A pad of crushed rock (2 feet wide by 3 feet long by 6 inches deep) shall be placed at each discharge point.
- No erosion or flooding of downstream properties may result.
- Runoff discharged towards landslide hazard areas must be evaluated by a geotechnical engineer or qualified geologist. The discharge point shall not be placed on or above slopes greater than 20% or above erosion hazard areas without evaluation by a geotechnical engineer or qualified geologist and approval by the City.
- For sites with septic systems, the discharge point should be downgradient of the drainfield primary and reserve areas. This requirement may be waived by the City if site topography clearly prohibits flows from intersecting the drainfield or where site conditions indicate that this is unnecessary (see Volume III, Chapter 3).

## **BMP T5.12 Sheet Flow Dispersion**

### ***Purpose and Definition***

Sheet flow dispersion is the simplest method of runoff control. This BMP can be used for any impervious or pervious surface that is graded so as to avoid concentrating flows. Because flows are already dispersed as they leave the surface, they need only traverse a narrow band of adjacent vegetation for effective attenuation and treatment.

### ***Applications and Limitations***

Flat or moderately sloping (<15% slope) impervious surfaces such as driveways, sport courts, patios, and roofs without gutters; sloping cleared areas that are comprised of bare soil, non-native landscaping, lawn, and/or pasture; or any situation where concentration of flows can be avoided.

### ***Design Guidelines***

- See Figure 5.5 for details for driveways.
- A 2-foot-wide transition zone to discourage channeling should be provided between the edge of the driveway pavement and the downslope vegetation, or under building eaves. This may be an extension of subgrade material (crushed rock), modular pavement, drain rock, or other material acceptable to the City.
- A vegetated buffer width of 10 feet of vegetation must be provided for up to 20 feet of width of paved or impervious surface. An additional 5 feet of width must be added for each additional 20 feet of width or fraction thereof.
- A vegetated buffer width of 25 feet of vegetation must be provided for up to 150 feet of contributing cleared area (i.e., bare soil, non-native landscaping, lawn, and/or pasture). Slopes within the 25-foot minimum flowpath through vegetation should be no steeper than 8 percent. If this criterion cannot be met due to site constraints, the 25-foot flowpath length must be increased 1.5 feet for each percent increase in slope above 8%.
- No erosion or flooding of downstream properties may result.
- Runoff discharge toward landslide hazard areas must be evaluated by a geotechnical engineer or a qualified geologist. The discharge point may not be placed on or above slopes greater than 20% or above erosion hazard areas without evaluation by a geotechnical engineer or qualified geologist and approval by the City.
- For sites with septic systems, the discharge point must be downgradient of the drainfield primary and reserve areas. This requirement may be waived by the City if site topography clearly prohibits flows from intersecting the drainfield or where site conditions indicate that this is unnecessary (see Volume III, Chapter 3).

## **BMP T5.13 Post-Construction Soil Quality and Depth**

### ***Purpose and Definition***

Naturally occurring (undisturbed) soil and vegetation provide important storm water functions including: water infiltration; nutrient, sediment, and pollutant adsorption; sediment and pollutant biofiltration; water interflow storage and transmission; and pollutant decomposition. These functions are largely lost when development strips away native soil and vegetation and replaces it with minimal topsoil and sod. Not only are these important storm water functions lost, but such landscapes themselves become pollution generating pervious surfaces due to increased use of pesticides, fertilizers and other landscaping and household/industrial chemicals, the concentration of pet wastes, and pollutants that accompany roadside litter.

Establishing soil quality and depth regains greater storm water functions in the post development landscape, provides increased treatment of pollutants and sediments that result from development and habitation, and minimizes the need for some landscaping chemicals, thus reducing pollution through prevention.

### ***Applications and Limitations***

Establishing a minimum soil quality and depth is not the same as preservation of naturally occurring soil and vegetation. It also does not maximize the storm water functions that could be attained through greater soil depth and more specialized formulations as presented in BMP T5.35, Engineered Soil/Landscape Systems. However, establishing a minimum soil quality and depth will provide improved on-site management of storm water flow and water quality.

Soil organic matter can be attained through numerous materials such as compost, composted woody material, biosolids, and forest product residuals. It is important that the materials used to meet the soil quality and depth BMP be appropriate and beneficial to the plant cover to be established. Likewise, it is important that imported topsoils improve soil conditions and do not have an excessive percent of clay fines.

### ***Design Guidelines***

- Soil retention. The duff layer and native topsoil should be retained in an undisturbed state to the maximum extent practicable. In any areas requiring grading, remove and stockpile the duff layer and topsoil on site in a designated, controlled area, not adjacent to public resources and critical areas, to be reapplied to other portions of the site where feasible.
- Soil quality. All areas subject to clearing and grading that have not been covered by impervious surface, incorporated into a drainage facility or engineered as structural fill or slope shall, at project completion, demonstrate the following:
  1. Retention or enhancement of the moisture infiltration rate and soil moisture holding capacity of the original undisturbed soil native to the site. Areas which have been compacted or have removed



some or all of the duff layer or underlying top soil shall be amended to mitigate for lost moisture infiltration and moisture holding capacity; and

2. A topsoil layer with a minimum organic matter content of ten percent dry weight and a pH from 6.0 to 8.0 or matching the pH of the original undisturbed soil. The topsoil layer shall have a minimum depth of eight inches except where tree roots limit the depth of incorporation of amendments needed to meet the criteria. Subsoils below the topsoil layer should be scarified at least 4 inches with some incorporation of the upper material to avoid stratified layers, where feasible (see Volume II).
- These criteria can be met by using on-site native topsoil, incorporating amendments into on-site soil, or importing blended topsoil. If blended topsoil is imported, then fines should be limited to twenty-five percent passing through a 200 sieve.
  - The resulting soil should be conducive to the type of vegetation to be established.

### ***Maintenance***

- Soil quality and depth should be established toward the end of construction and once established, should be protected from compaction, such as from large machinery use, and from erosion.
- Soil should be planted and mulched after installation.
- Plant debris or its equivalent should be left on the soil surface to replenish organic matter.
- It should be possible to reduce use of irrigation, fertilizers, herbicides and pesticides. These activities should be adjusted where possible, rather than continuing to implement formerly established practices.

### **5.3.2 Site Design BMPs**

The two BMPs in this section are general practices for design and maintenance at the site.

#### **BMP T5.20 Preserving Natural Vegetation**

##### ***Purpose And Definition***

Preserving natural vegetation on-site to the maximum extent practicable will minimize the impacts of development on storm water runoff. Ecology prefers that 65 percent or more of the development site should be protected for the purposes of retaining or enhancing existing forest cover and preserving wetlands and stream corridors.

##### ***Applications and Limitations***

New development often takes place on tracts of forested land. In fact, building sites are often selected because of the presence of mature trees. However, unless sufficient care is taken and planning done, in the interval between buying the property and completing construction much of this resource is likely to be destroyed. The property owner is ultimately responsible for protecting as many trees as possible, with their understory and groundcover. This responsibility is usually exercised by agents, planners, designers, and contractors. It takes 20 to 30 years for newly planted trees to provide the benefits for which trees are so highly valued.

Forest and native growth areas allow rainwater to naturally percolate into the soil, recharging groundwater for summer stream flows and reducing storm water runoff that creates erosion and flooding. Conifers can hold up to about 50 percent of all rain that falls during a storm. Twenty to 30 percent of this rain may never reach the ground but evaporates or is taken up by the tree. Forested and native growth areas also may be effective as storm water buffers around smaller developments.

On lots that are one acre or greater, preservation of 65 percent or more of the site in natural vegetation will allow the use of full dispersion techniques presented in BMP T5.30. Sites that can fully disperse are not required to provide runoff treatment or flow control facilities.

##### ***Design Guidelines***

- The preserved area should be situated to minimize the clearing of existing forest cover, to maximize the preservation of wetlands, and to buffer stream corridors.
- The preserved area should be placed in a separate tract or protected through recorded easements for individual lots.
- If feasible, the preserved area should be located downslope from the building sites, since flow control and water quality are enhanced by flow dispersion through duff, undisturbed soils, and native vegetation.

- The preserved area should be shown on all property maps and should be clearly marked during clearing and construction on the site.

***Maintenance***

- Vegetation and trees should not be removed from the natural growth retention area, except for approved timber harvest activities and the removal of dangerous and diseased trees.

## **BMP T5.21 Better Site Design**

### ***Purpose and Definition***

Fundamental hydrological concepts and storm water management concepts can be applied at the site design phase that are:

- more integrated with natural topography,
- reinforce the hydrologic cycle,
- more aesthetically pleasing, and
- often less expensive to build.

A few site planning principles help to locate development on the least sensitive portions of a site and accommodate residential land use while mitigating its impact on storm water quality.

### ***Design Guidelines***

- **Define Development Envelope and Protected Areas** - The first step in site planning is to define the development envelope. This is done by identifying protected areas, setbacks, easements and other site features, and by consulting applicable local standards and requirements. Site features to be protected may include important existing trees, steep slopes, erosive soils, riparian areas, or wetlands.

By keeping the development envelope compact, environmental impacts can be minimized, construction costs can be reduced, and many of the site's most attractive landscape features can be retained. In some cases, economics or other factors may not allow avoidance of all sensitive areas. In these cases, care can be taken to mitigate the impacts of development through site work and other landscape treatments.

- **Minimize Directly Connected Impervious Areas** - Impervious areas directly connected to the storm drain system are the greatest contributors to urban nonpoint source pollution. Any impervious surface that drains into a catch basin or other conveyance structure is a "directly connected impervious surface." As storm water runoff flows across parking lots, roadways, and other paved areas, the oil, sediment, metals, and other pollutants are collected and concentrated. If this runoff is collected by a drainage structure and carried directly along impervious gutters or in sealed underground pipes, it has no opportunity for filtering by plant material or infiltration into the soil. It also increases in velocity and amount, causing increased peak-flows in the winter and decreased base-flows in the summer.

A basic site design principle for storm water management is to minimize these directly connected impervious areas. This can be

done by limiting overall impervious land coverage or by infiltrating and/or dispersing runoff from these impervious areas.

- **Maximize Permeability** - Within the development envelope, many opportunities are available to maximize the permeability of new construction. These include minimizing impervious areas, paving with permeable materials, clustering buildings, and reducing the land coverage of buildings by smaller footprints. All of these strategies make more land available for infiltration and dispersion through natural vegetation.

Clustered driveways, small visitor parking bays and other strategies can also minimize the impact of transportation-related surfaces while still providing adequate access.

Once site coverage is minimized through clustering and careful planning, pavement surfaces can be selected for permeability. A patio of brick-on-sand, for example, is more permeable than a large concrete slab. Engineered soil/landscape systems are permeable ground covers suitable for a wide variety of uses. Permeable/porous pavements can be used in place of traditional concrete or asphalt pavements in many low traffic applications.

Maximizing permeability at every possible opportunity requires the integration of many small strategies. These strategies will be reflected at all levels of a project, from site planning to materials selection. In addition to the environmental and aesthetic benefits, a high-permeability site plan may allow the reduction or elimination of expensive runoff underground conveyance systems, flow control and treatment facilities, yielding significant savings in development costs.

- **Build Narrower Streets** - More than any other single element, street design has a powerful impact on storm water quantity and quality. In residential development, streets and other transportation-related structures typically can comprise between 60 and 70 percent of the total impervious area, and, unlike rooftops, streets are almost always directly connected to the storm water conveyance system.

The combination of large, directly connected impervious areas, together with the pollutants generated by automobiles, makes the street network a principal contributor to storm water pollution in residential areas.

- **Maximize Choices for Mobility** - Given the costs of automobile use, both in land area consumed and pollutants generated, maximizing choices for mobility is a basic principle for environmentally responsible site design. By designing residential developments to promote alternatives to automobile use, a primary source of storm water pollution can be mitigated.

Bicycle lanes and paths, secure bicycle parking at community centers and shops, direct, safe pedestrian connections, and transit facilities are all site-planning elements that maximize choices for mobility.

- **Use Drainage as a Design Element** - Unlike conveyance storm drain systems that hide water beneath the surface and work independently of surface topography, a drainage system for storm water infiltration or dispersion can work with natural land forms and land uses to become a major design element of a site plan.

By applying storm water management techniques early in the site plan development, the drainage system can suggest pathway alignments, optimum locations for parks and play areas, and potential building sites. In this way, the drainage system helps to generate urban form, giving the development an integral, more aesthetically pleasing relationship to the natural features of the site. Not only does the integrated site plan complement the land, it can also save on development costs by minimizing earthwork and expensive drainage features.

### ***Resource Material***

Start at the Source. Residential Site Planning & Design Guidance Manual for Stormwater Quality Protection. Bay Area Stormwater Management Agencies Association. January 1997.

Site Planning for Urban Stream Protection. Center for Watershed Protection. December, 1995.

Better Site Design: A Handbook for Changing Development Rules in Your Community. Center for Watershed Protection. August 1998.

<http://www.stormwatercenter.net>

### 5.3.3 Other Practices

The BMPs described in this section are other general practices for on-site treatment of storm water.

#### **BMP T5.30 Full Dispersion**

##### ***Purpose and Definition***

This BMP allows for "fully dispersing" runoff from impervious surfaces and cleared areas of development sites that protect at least 65% of the site (or a threshold discharge area on the site) in a forest or native condition.

##### ***Applications and Limitations***

- Rural single-family residential developments should use these dispersion BMPs wherever possible to minimize effective impervious surface to less than 10% of the development site.
- Other types of development that retain 65% of the site (or a threshold discharge area on the site) in a forested or native condition may also use these BMPs to avoid triggering the flow control facility requirement.

##### ***Design Guidelines***

- **Roof Downspouts** - Roof surfaces that comply with the downspout infiltration requirements in Volume III, Chapter 3, are considered to be "fully dispersed" (i.e., zero percent effective imperviousness). All other roof surfaces are considered to be "fully dispersed" (i.e., at or approaching zero percent effective imperviousness) only if they are within a threshold discharge area that is or will be more than 65% forested (or native vegetative cover) and less than 10% impervious (total), **and** if they comply with the downspout dispersion requirements of BMP T5.10, and have vegetated flow paths through native vegetation exceeding 100 feet.
- **Driveway Dispersion** - Driveway surfaces are considered to be "fully dispersed" if they are within a threshold discharge area that is or will be more than 65% forested (or native vegetative cover) and less than 10% impervious (total), **AND** if they comply with the driveway dispersion BMPs – BMP 5.11 and BMP T5.12 - and have flow paths through native vegetation exceeding 100 feet. This also holds true for any driveway surfaces that comply with the roadway dispersion BMPs described below.
- **Roadway Dispersion BMPs** - Roadway surfaces are considered to be "fully dispersed" if they are within a threshold discharge area that is or will be more than 65% forested (or native vegetative cover) and less than 10% impervious (total), **and** if they comply with the following dispersion requirements:

1. Roadway runoff dispersion is allowed only on rural neighborhood collectors and local access streets. To the extent feasible, driveways should be dispersed to the same standards as roadways to ensure adequate water quality protection of downstream resources.
2. The road section shall be designed to minimize collection and concentration of roadway runoff. Sheet flow over roadway fill slopes (i.e., where roadway subgrade is above adjacent right-of-way) should be used wherever possible to avoid concentration.
3. When it is necessary to collect and concentrate runoff from the roadway and adjacent upstream areas (e.g., in a ditch on a cut slope), concentrated flows shall be incrementally discharged from the ditch via cross culverts or at the ends of cut sections. These incremental discharges of newly concentrated flows shall not exceed 0.5 cfs at any one discharge point from a ditch for the 100-year runoff event. Where flows at a particular ditch discharge point were already concentrated under existing site conditions (e.g., in a natural channel that crosses the roadway alignment), the 0.5-cfs limit would be in addition to the existing concentrated peak flows.
4. Ditch discharge points with up to 0.2 cfs discharge for the peak 100-year flow shall use rock pads or dispersion trenches to disperse flows. Ditch discharge points with between 0.2 and 0.5 cfs discharge for the 100-year peak flow shall use only dispersion trenches to disperse flows.
5. Dispersion trenches shall be designed to accept storm flows (free discharge) from a pipe, culvert, or ditch end, shall be aligned perpendicular to the flowpath, and shall be minimum 2 feet by 2 feet in section, 50 feet in length, filled with  $\frac{3}{4}$ -inch to  $1\frac{1}{2}$ -inch washed rock, and provided with a level notched grade board (see Figure 5.2). Manifolds may be used to split flows up to 2 cfs discharge for the 100-year peak flow between up to 4 trenches. Dispersion trenches shall have a minimum spacing of 50 feet.
6. After being dispersed with rock pads or trenches, flows from ditch discharge points must traverse a minimum of 100 feet of undisturbed native vegetation before leaving the project site, or entering an existing onsite channel carrying existing concentrated flows across the road alignment.

*Note: In order to provide the 100-foot flowpath length to an existing channel, some roadway runoff may unavoidably enter the channel undispersed. Also note that water quality treatment may be waived for roadway runoff dispersed through 100 feet of undisturbed native vegetation.*
7. Flowpaths from adjacent discharge points must not intersect within the 100-foot flowpath lengths, and dispersed flow from a discharge point must not be intercepted by another discharge point. To enhance the flow control and water quality effects of



dispersion, the flowpath shall not exceed 15% slope, and shall be located within designated open space.

*Note: Runoff may be conveyed to an area meeting these flowpath criteria.*

8. Ditch discharge points shall be located a minimum of 100 feet upgradient of steep slopes (i.e., slopes steeper than 40%), wetlands, and streams.
9. Where the City determines there is a potential for significant adverse impacts downstream (e.g., erosive steep slopes or existing downstream drainage problems), dispersion of roadway runoff may not be allowed, or other measures may be required. See Volume I, Chapter 2 for geographic specific requirements.

- **Cleared Area Dispersion BMPs**

The runoff from cleared areas that are comprised of bare soil, non-native landscaping, lawn, and/or pasture is considered to be "fully dispersed" if it is dispersed through at least 25 feet of native vegetation in accordance with the following criteria:

1. The contributing flowpath of cleared area being dispersed must be no more than 150 feet, and
2. Slopes within the 25-foot minimum flowpath through native vegetation should be no steeper than 8%. If this criterion cannot be met due to site constraints, the 25-foot flowpath length must be increased 1.5 feet for each percent increase in slope above 8%.

## **BMP T5.31 Vegetated Rooftops (Green Roofs)**

### ***Purpose and Definition***

Vegetated rooftops, also known as green roofs or eco-roofs, are veneers of living vegetation that are installed on top of conventional roofs. A green roof is an extension of the existing roof, which involves a special root repelling membrane, a drainage system, a lightweight growing medium, and plants.

### ***Applications and Limitations***

Vegetated rooftops offer a practical method of managing runoff in densely developed urban neighborhoods and can be engineered to achieve specific storm water runoff control objectives.

### ***Design Guidelines***

Vegetated rooftops achieve runoff control by mimicking a variety of hydrologic processes that are associated with open space. These include:

- Interception of rainfall by foliage
- Direct runoff
- Infiltration
- Percolation
- Shallow subterranean flow (i.e., analogous to shallow groundwater flow)
- Root zone moisture uptake and subsequent evapotranspiration

In a vegetated roof cover, all of these functions occur in a thin layer, typically 10 to 20 cm in depth. Through careful design, these hydrologic processes can be modulated to achieve specific outcomes. Vegetated roof covers can be considered as falling into three categories. These are:

1. Single layer system with free drainage.
2. Multi-layer system with a freely-drained basal drainage layer.
3. Multi-layer system, incorporating restricted drainage that causes a free water surface to form inside the drainage layer (integral storage).

It is important to properly specify the hydraulic properties of materials used in constructing vegetated roof covers. Both the growth media and the drainage layer play an important role in controlling runoff. Growth media properties, including saturated hydraulic conductivity, porosity, and moisture retention exert influence when the cover is dry. When the cover has been soaked by antecedent rainfall, the transmissivity of the drainage layer is more important.

It is important to consider practical limitations as well as hydraulic considerations. Hydraulic conductivity of growth media should not be less than 0.03 cm/min to prevent anaerobic conditions from becoming established. Designs that incorporate less transmissive drainage layers will be associated with the transient build-up of hydrostatic pressure over some areas of the waterproofing membrane. This may not be desirable, especially in retrofit situations.

Allowable load capacities of roofs may also constrain the depth of cover.

***Resource Material***

Miller, C. and Grantley Pyke. Methodology for the Design of Vegetated Roof Covers, Proceedings of the 1999 International Water Resources Engineering Conference, Seattle, Washington.

## **BMP T5.32 Cisterns**

### ***Purpose and Definition***

A cistern is a vessel that allows storage and use of roof runoff. Cisterns may be either an above ground vessel with a manually operated valve or permanently open outlet or a below ground vessel with a pump. Cisterns should provide at least 1,000 gallons of storage to have any significant hydrologic effect.

### ***Applications and Limitations***

If the cistern has an operable valve, the valve can be closed to store storm water for irrigation use or infiltration between storms. This system requires continual monitoring by the resident or grounds crew, but provides greater flexibility in water storage and metering. If a cistern is provided with an operable valve and water is stored inside for long periods, the cistern must be covered to prevent mosquitoes from breeding.

A cistern system with a permanently open outlet can also provide for metering storm water runoff. If the cistern outlet is significantly smaller than the size of the downspout inlet (e.g.  $\frac{1}{4}$  or  $\frac{1}{2}$  inch diameter), runoff will build up inside the cistern during storms, and will empty out slowly after peak intensities subside.

Cisterns require active management and maintenance by all future property owners in order to provide any long-term benefit.

### ***Design Guidelines***

- Cisterns can be incorporated into the aesthetics of the building and garden.
- If a cistern holds more than 6 inches depth of water, it should be covered securely or have a top opening of 4 inches or less to prevent small children from gaining access to the standing water.
- The cistern should be designed and maintained to minimize clogging by leaves and other debris.
- Design information is available from the University of Florida Cooperative Extension Service at <http://edis.ifas.ufl.edu>.

## **BMP T5.33 Concave Vegetated Surfaces**

### ***Purpose and Definition***

A landscape surface is graded to have a slightly concave slope to collect storm water and promote infiltration.

### ***Applications and Limitations***

Landscape surfaces are conventionally graded to have a slight convex slope, causing water to run off a central high point into a surrounding drainage system. If a landscape surface is graded to have a slightly concave slope, it will hold water. Conventional practice in a concave vegetated surface is to place an area drain or catch basin at the center to collect storm water. If the drain is placed not in the central low spot, but at the high edge, just below the adjacent pavements, then the concave surface will hold water until it reaches the level of the catch basin. In locations where a storm drainage system is used, a check dam can serve as an alternative to the overflow drain, allowing the water to overflow from the concave vegetated surface into a swale system.

### ***Design Guidelines***

Concave vegetated surfaces need not be very deep to make a significant contribution to overall storm storage capacity and storm water quality. For example, a square lawn area 50 feet on a side, sloping 2 percent towards the center will create a low point 6 inches below the outside rim. This 6-inch slope over 25 feet of distance is barely noticeable, and is similar to standard grading practice for lawn areas. This 50-foot x 50-foot x 6-inch deep lawn area creates a storage capacity of 413 cubic feet. If adjacent impervious surfaces, such as sidewalks, rooftops, and roads are designed to sheet flow into this concave lawn, their runoff can gradually infiltrate into the soil.

If a series of concave vegetated surfaces are designed and located to collect and hold runoff from small storms, most pollutants and storm water can be controlled on-site. Catch basins located at the edge of the concave vegetated surfaces can collect runoff from larger storms.

Effectiveness can be enhanced by the presence of a properly functioning soil system. This requires appropriate soil depth and composition to ensure both short-term and long-term filtration effectiveness. Substantial filtration, retention, and pollution control can occur if soil depths of 8 inches or more are present. Soils should be designed per BMP T5.13, Post-Construction Soil Quality And Depth.

## **BMP T5.34 Multiple Small Basins**

### ***Purpose and Definition***

Multiple small infiltration basins or wetponds are designed on site.

### ***Applications and Limitations***

Multiple small basins can provide a great deal of water storage and infiltration capacity. These small basins can fit into the parkway planting strips. If connected by culverts under walks and driveways, they can create a continuous linear infiltration system. Infiltration basins can be placed under wood decks, in parking lot planter islands, and at roof downspouts. Outdoor patios or seating areas can be sunken a few steps, paved with a permeable pavement such as flagstone or gravel, and designed to hold a few inches of water collected from surrounding rooftops or paved areas for a few hours after a rain.

Rain gardens can be planned and integrated into both new and existing developments. A rain garden combines shrubs, grasses, trees and plants in depressions (about 6 inches deep) that allow water to pool after a rain event. The plants in the rain garden absorb the water and remove nutrients for a very low cost.

These examples of small basins can store water for a brief period, allowing it to infiltrate into the soil, slowing its release into the drainage network, and filtering pollutants.

Effectiveness can be enhanced by the presence of a properly functioning soil system. This requires appropriate soil depth and composition to ensure both short-term and long-term filtration effectiveness. Substantial filtration, retention, and pollution control can occur if soil depths of 8 inches or more are present. Soils should be designed per BMP T5.13, Post-Construction Soil Quality And Depth

## **BMP T5.35 Engineered Soil/Landscape Systems**

### ***Purpose and Definition***

The engineered soil/landscape system is a self-sustaining soil and plant system that simultaneously supports plant growth, soil microbes, water infiltration, nutrient and pollutant adsorption, sediment and pollutant biofiltration, water interflow, and pollutant decomposition.

### ***Applications and Limitations***

Installing an engineered soil/landscape system is not the same as preservation of natural vegetation. However, it can provide improvements to both the post-development plant and soil systems and help them function more effectively. This provides a soil/landscape system with adequate depth, permeability, and organic matter to sustain itself by creating a sustainable nutrient cycle.

Amending existing landscapes and turf systems to improve depth, permeability, and percent organic matter can substantially improve the disease and drought resistance of the vegetation and reduce fertilizer demand. Organic matter is the least water-soluble form of nutrient that can be added to the soil. Composted organic matter generally releases only between 2 and 10 percent of its total nitrogen annually, and this release corresponds closely to many plant growth cycles. If natural plant debris and mulch are returned to the soil this system can continue regenerating natural nutrients indefinitely.

Landscaped areas are frequently used to treat and infiltrate runoff from adjacent impervious areas. They are also used in treatment BMPs for removal of pollutants, control of peak flows, and control of erosion. However, the standard modeling approach for hydrologic analysis and flow control prescribes that designers use only marginal values for lawns and landscaping. The best runoff performance allowed for lawns and landscapes is less than that of pasture, grasslands, and woods. Providing an engineered soil/landscape system allows the designer to use the landscape as a flow control system.

### ***Design Guidelines***

Provide an engineered soil/landscape system that has the following characteristics:

- Protected from compaction and erosion.
- A plant system (landscape design) to support a sustained soil quality.
- A soil depth that is equivalent to pasture and grassland in runoff curve numbers.
- Permeability characteristics of greater than or equal to 6.0, 2.0, 0.6, and less than 0.6 inches/hour for hydrologic soil groups A, B, C, and D, respectively (per ASTM D 3385).

- Minimum percent organic matter of 12, 14, 16, and 18 percent for hydrologic soil groups A, B, C, and D, respectively (per ASTM D 2974).

### ***Maintenance***

The system should be protected from compaction and erosion. Compaction should be prevented using BMP T5.36.

- The system should be planted or mulched after installation.
- Plant debris or its equivalent should be left on the soil surface.
- Pesticides and herbicides should be used infrequently or not at all.
- Fertilizer, if used, should be applied in the form of organic matter, organic-based, or in a slow-release, non-water soluble form.



## **BMP T5.36 Soil Compaction Protection and Mitigation**

### ***Purpose and Definition***

Landscaped areas are frequently used to treat and infiltrate runoff from adjacent impervious areas. They are also used in treatment BMPs for removal of pollutants, control of peak flows, and control of erosion. Compaction and permeability are directly related. As landscapes mature, they often become more compact due to loss of organic matter, climate- and pathogen-related stress on landscape plantings, foot traffic, vehicle/mower pressures, turf thatching, and similar activities.

Provide protection from compaction through the use of amendments. These include, but are not limited to, organic matter, coarse sand, pumice, granulated rubber, and similar soil components. Also provide protection from compaction through appropriate landscape plant selection and placement, and by defining foot traffic and vehicle pathways.

### ***Design Guidelines***

- Compost (WSDOT standard specification 8-02, section 8-12.2 with supplement 02021.FR8) can be used to increase organic matter to the 12 to 18 percent range.
- Coarse sand and pumice can be added to improve permeability. Clay soils may respond differently than other soils. For clay soils, the organic matter should be added first, and then sand or pumice added as a final ingredient to prevent the creation of an impermeable, cement-like matrix.
- Lawns can be aerated and then top-dressed with appropriate amendments to improve permeability.
- Granulated (crumb) rubber has successfully been incorporated into lawns, golf courses (EPA Publication 530-F-97-043), and athletic fields to improve permeability and resistance to compaction where the surface has constant and heavy use.
- Landscapes that are designed to prevent excessive foot traffic and vehicle/mower compression can better retain their permeability.
- Landscapes should have well-defined pathways that are designed to withstand frequent or excessive foot traffic and vehicle compression.

### **5.3.4 Permeable/Porous Pavements**

The BMPs described in this section relate to the use of porous and permeable concrete and asphalt.

#### **BMP T5.40 Porous Concrete and Porous Asphalt**

##### ***Purpose and Definition***

Porous concrete, also known as “no fines concrete,” is a special type of concrete that allows storm water to pass through it, thereby reducing the runoff from a site. In addition, porous concrete provides runoff treatment through filtration and allows for groundwater recharge.

Porous concrete or “No Fines Concrete Paving” is a structural, open textured pervious concrete paving surface consisting of standard Portland cement, fly ash, locally available open graded coarse aggregate, admixtures, fibers, and potable water. When properly handled and installed, porous concrete has a high percentage of void space (approximately 17-22%), which allows rapid percolation of storm water through the pavement. Figure 5.6 illustrates a porous concrete paving section.

Porous asphaltic paving material consists of an open graded coarse aggregate cemented together by asphalt cement into a coherent mass, with sufficient interconnected voids to provide a high rate of permeability to water. Figure 5.7 illustrates a porous asphalt paving section.

##### ***Applications and Limitations***

Porous concrete and asphalt pavements are a replacement for conventional asphalt pavement or other hard paving surfaces provided that the grades, subsoil drainage characteristics and groundwater table conditions are suitable for its use:

- Not recommended on slopes greater than 5 percent and best with slopes as flat as possible
- The minimum infiltration rate in the subsoils should be 0.25 inches per hour. Infiltration rates less than 2.4 inches per hour and a cation exchange capacity of 5 milliequivalents CEC/100 grams dry soil or greater will provide water quality treatment in the subsoils.
- Minimum depth to bedrock and seasonally high water table should be 3 feet.

Possible areas for use of this paving material include:

- Commercial, public, and municipal parking lots, including perimeter and overflow parking areas;
- Parking aprons, taxiways, and runway shoulders at airports;

- Vehicle access areas, including roadway shoulders, medians, fire lanes, on-street parking areas, emergency stopping lanes, and vehicle cross-overs on divided highways;
- Low-speed residential roads;
- Residential driveways, patios, sidewalks, and sport courts;
- Sidewalks, bicycle trails, golf cart paths, community trail/pedestrian path systems, or any pedestrian accessible paved area,
- Areas where additional drainage capabilities are desired with improved structural capacity such as soccer fields, open space areas, or drainage fields; and
- Fill or underlayment for precast, modular paver, or grid systems.

This BMP functions as an infiltration and retention area that can accommodate pedestrians, light and heavy load parking areas, is applicable in most impervious applications in both residential and commercial applications. This combination of functions offers the following benefits:

- Allows site precipitation to reach the root systems for plants and vegetation;
- Mimics natural soils filtration throughout the pavement depth, underlying subbase drainage filter and native soils for improved groundwater quality;
- Reduction of storm water runoff temperatures;
- Increased recharge of groundwater;
- Allows for natural infiltration characteristics of native area soils;
- Elimination of typical random cracking patterns commonly found in improperly jointed concrete;
- Year round construction ability; and
- Use of locally available aggregates.

Handling and placement practices for porous concrete are different from conventional concrete placement. Placement should be completed by contractors with experience in placing porous concrete. In the absence of experience in placement, contractors should be required to view instructional porous concrete construction videos.

If perimeter, narrow, or integral porous concrete strips are to be used in conjunction with “hard” pavements, drainage curtains should be provided to prevent water migration under adjacent paved areas. Consideration should also be given to areas immediately adjacent to porous concrete edges to minimize spill over of soils or other easily dislodged fine particles.

Pervious pavements should not be used in high vehicle traffic areas.

### ***Design Criteria***

- Drainage time for the design storm: minimum is 12 hours, maximum is 72 hours, recommended is 24 hours.
- Run-on to the pavement from offsite areas is not allowed.
- On-site soils should be tested for porosity, permeability, and cation exchange capacity. These properties should be considered when designing the subbase layer.
- Subgrade soils should be uniformly compacted and prepared in accordance with other pavement design considerations.
- The gradation required to obtain a porous concrete pavement is of the “open” graded or coarse type. Generally 5/8-inch or 3/8-inch minus crushed materials are preferred. Readily available aggregates should be considered as not all gradations are locally available. Recycled aggregates are encouraged for open graded subbase materials.
- Local guidelines relative to specifying and constructing, and suggested design procedures for use of pervious concrete are available through the Washington Aggregates & Concrete Association, 399 114<sup>th</sup> Ave. NE, Bellevue, WA 98004 (or through the website at [www.washingtonconcrete.org](http://www.washingtonconcrete.org)). These suggested guidelines will assist material suppliers, contractors, specifying agencies and design professionals in the proper procedures used to place porous concrete.

### ***Operation and Maintenance***

- Routine maintenance involves removal of debris that is too coarse to be washed through the pavement system. Vacuuming pavement is required to remove particulates that are fine enough to be carried into the pavement but too large to pass through, thus clogging the void space. Porous pavements require no more repair maintenance than conventional pavements, so maintenance problems can generally be reduced to better “housekeeping” practices on the part of area residents and more efficient street cleaning procedures in municipalities.
- Pervious pavements may have a tendency to clog if improperly maintained. Maintenance procedures include standard vacuum trucks, street sweepers, leaf blowers, and other practices to remove or prevent leaves, needles, or other foliage from collecting in parking areas and streets. Should clogging occur, it is usually limited to spot areas. Remedies include localized vacuuming and power washing and, in severe cases, the clogged area may be removed and replaced.
- Clogging can be prevented by waiting until all other phases of construction are complete; covering and protecting until all landscaping, topsoil import, or hydroseeding are complete; avoiding areas where any pervious pavement would not be successful; and by regular inspection and preventive maintenance practices.

- If spills occur, they should be immediately vacuumed up followed by a pressure wash or other appropriate rinse procedure. This treatment will restore permeability to almost prespill levels (95 percent).

### ***Resource Material***

Virginia State Water Control Board, Best Management Practices Handbook: Urban, Planning Bulletin 321, Richmond, Virginia, 1979.

Thelen, E. and L.F. Howe, Porous Pavement, The Franklin Institute Press, Philadelphia. PA, 1978.

Thelen, E. et al., Investigation of Porous Pavements for Urban Runoff Control, prepared by the Franklin Institute Research Laboratories for the U.S. Environmental Protection Agency, NTIS PB-227-5, Springfield, VA, 1972.

Smith, R.W., J.M. Rice and S.R. Spelman, Design of Open Graded Asphalt Friction Courses, Federal Highway Administration, U.S. Department of Transportation, FHWA-RD-74-2, 1974.

United States Environmental Protection Agency, Storm Water Technology Fact Sheet, Porous Pavement, EPA 832-F-99-023, September 1999.

## **BMP T5.41 Porous Pavers**

### ***Purpose and Definition***

The various porous paver materials available commercially can be separated into the following categories:

- Flexible plastic cellular confinement systems. Examples include Geoweb, Grasspave 2 and Gravelpave 2, and GRASSY™ PAVERS.
- Molded plastic materials. Examples include Geoblock and Checkerblock.
- Interlocking concrete blocks. Examples include UNI Eco-stone and Turfstone. See BMP T5.42 for further information on these systems.
- Cast-in-place concrete blocks. These are made with reusable forms to create voids needed for planting grass. They can be reinforced with welded wire mesh to prevent differential settlement. Grasscrete is an example of this technology.

### ***Application and Limitations***

Appropriate soil conditions and the protection of groundwater are among the important considerations that may limit the use of this BMP.

Modular pavement is applicable where pavement is desirable or required for low-volume traffic areas. This practice is most applicable for new construction, but it can be used in existing developments to expand a parking area or even to replace existing pavement if that is a cost-effective measure, or for aesthetic reasons.

Possible areas for use of these paving materials include:

- Parking aprons, taxiways, blast pads, and runway shoulders at airports (heavier loads may demand the use of reinforced grid systems).
- Emergency stopping and parking lanes and vehicle crossovers on divided highways.
- On-street parking aprons in residential neighborhoods.
- Recreational vehicle camping area parking pads.
- Private roads, easement service roads and fire lanes.
- Industrial storage yards and loading zones (heavier loads may demand the use of reinforced grid systems).
- Driveways for residential and light commercial use.
- Bike paths, walkways, patios and swimming pool aprons.

### ***Design Criteria***

Modular pavement systems vary considerably in configuration. Categories include:

- Pre-Cast Concrete Grids - Concrete paving units incorporating void areas are usually precast in a concrete products plant and trucked to a job site for placement on the ground. However, for large jobs these units can be formed and cast at the site. There are two types of grid pavers:
  1. Lattice Pavers - Generally flat and grid-like in surface configuration.
  2. Castellated Pavers - Distinguished by a more complex surface configuration characterized by crenels and merlons that are exposed when pervious materials are added. These units show a higher percentage of grass surface.
- Modular Unit Pavers - Smaller pavers which may be clay bricks, granite sets, or cast concrete of various shapes. These pavers are monolithic units which do not have void areas incorporated into their configuration. They are installed on the ground to be covered with pervious material placed in the gaps between the units.

### ***Construction Criteria***

All installations of modular pavement should be designed and constructed according to the manufacturer's specifications. To be consistent with other forms of treatment, stored water must be percolated prior to the time limit specified for other on-site retention systems. However, facilities using vegetative cover in combination with pavers must be capable of disposing of stored waters within time limits necessary to avoid damage to the ground cover (24 to 36 hours for most grasses). Parking areas should avoid extensive ponding for periods exceeding more than an hour or two.

### ***Operation and Maintenance***

Where turf is incorporated into these installations, normal turf maintenance – watering, fertilizing, and mowing – will be necessary. Mowing is seldom required in areas of frequent traffic. It is documented that the hard surfaces in these installations require very little maintenance. However, fertilizers, pesticides and other chemicals may have adverse effects on concrete products. The use of such chemicals should be restricted as much as possible.

## **BMP T5.42 Permeable Interlocking Concrete Pavement**

### ***Description***

Permeable interlocking concrete pavement (PICP) combines high load-bearing strength with surface permeability through narrow jointing and a built-in pattern of openings. The openings are filled with aggregate and the pavers are typically placed on an open-graded aggregate base for storing runoff. Interlocking concrete pavements are typically constructed as flexible pavements on compacted soil subgrade and compacted aggregate base. The pavers are then placed on a thin layer of bedding sand, compacted, sand swept into the joints, and the units compacted again. When compacted the pavers interlock, transferring vertical loads from vehicles to surrounding pavers by shear forces through the joint sand. The sand in the joints enables applied loads to be spread in a manner similar to asphalt, reducing the stresses on the base and subgrade. PICP has patterns with openings or drainage holes for rainfall to enter, while maintaining high side-to-side contact among units for stability under vehicular loads (Figure 5.8).

### ***Applications and Limitations***

Typical applications include:

- Vehicular access (residential driveways, service driveways, roadway shoulders, crossovers, and medians, fire lanes and utility access)
- Parking areas
- Bicycle trails
- Golf course (cart paths, cart parking)
- Pedestrian access (approaches to monuments, statues, and foundations, areas for outdoor special events, picnic areas and highway waysides, pathways and trails, sidewalks, pedestrian plazas)
- Equestrian trails
- Roof plaza and parking decks

This BMP functions as an infiltration and retention area that can accommodate pedestrians, and vehicular parking and traffic. This combination of functions offers the following benefits:

- Filtration through the base and soil for improvement of water quality
- Reduction of runoff temperature
- Increased recharge of groundwater
- Reduction of overall project development costs due to reduction in storm sewers and drainage appurtenances
- Elimination of cracking normal to conventional asphalt and concrete pavements
- Accommodation of year-round construction
- Pavement can be opened and closed without using jackhammers, using less construction equipment, and reusing the same pavers (“reinstatement”).



PICP is not recommended for the following circumstances:

- When the depth from the bottom of the base to the high level of the water table is less than 4 feet, or when there is insufficient depth of soil to offer adequate filtering and treatment of water pollutants.
- Over solid rock without a loose rock layer above it.
- Over aquifers where there is insufficient depth of soil to filter the pollutants before entering the groundwater. These can include karst, fissured, or cleft aquifers.
- Over fill soils that can become unstable when saturated.

Should any of these conditions apply, an alternative design may incorporate “no infiltration” by using an impermeable liner to capture, store, and release runoff from the base. If infiltration is not provided and the total of new and/or replaced impervious surface is greater than 10,000 square feet, the underdrain must discharge through a flow control facility in compliance with Volume 1 of this manual. If infiltration is not provided and the underdrain is commingled with untreated runoff from other pollution generating surfaces in the conveyance system, the treatment facility for the project must be sized to include the flow from the PICP. In this case, the reduced curve numbers in Volume III, Chapter 2 for permeable pavement should not be used for sizing a treatment BMP. If the flow from the underdrain can be kept separate from untreated runoff from other pollution generating impervious surfaces, it may be discharged without further treatment.

Other considerations:

- Total catchment area draining into the permeable pavement cannot be greater than 15 acres.
- The pavement should be upslope from building foundations, and the foundations should have piped drainage at the footers.
- Land surrounding and draining into the pavement cannot exceed 20 percent slope.

### ***General Design Criteria***

A qualified and experienced geotechnical or civil engineer must complete the design of a PICP project. Zollinger et al (1998) and ICPI Tech Spec No. 4, Structural Design of Interlocking Concrete Pavement for Roads and Parking Lots provide detailed information on designing PICP. Dr. Shackel developed the Lockpave Pro computer program to assist in the structural design of interlocking concrete block pavements for a variety of applications. The structural design aspects of PICP are included in the program, as well as a hydraulic design program based on SWMM, the EPA's Stormwater Management Model.

Key performance factors include:

- Width of joints (0.08 - 0.12 in) between blocks and proper placement of the jointing sand.
- Use of edge restraints to facilitate development of shear between concrete blocks

- Minimal roughness in the initial construction of the longitudinal profile.
- Uniformity of the bedding layer (maintaining a thickness of 1-1.5 in) and proper compaction of pavers. Improperly designed and placed bed layers may result in premature rutting.
- Quality of materials (gradation, shape, etc.) should be as uniform as possible.
- Incorporate into design the proper balance between void ratio and gradation limits, and material stability and strength to simultaneously meet both the drainage and structural requirements of the design.

Pavement cross-section design options (Figures 5.9 through 5.13):

- Full or partial infiltration – A design for full infiltration uses an open-graded base with aggregate-filled joints for maximum infiltration and storage of storm water. The water infiltrates directly into the base and through the soil. Partial infiltration does not rely completely on infiltration through the soil to dispose all of the captured runoff. Some of the water may infiltrate into the soil and the remainder drained by pipes. In this latter case, the permeable pavement credit in the WWHM should not be turned on.
- No infiltration – No infiltration is desirable when the soil has low permeability and low strength, or there are other site limitations. An impermeable layer may be used if the pollutant loads are expected to exceed the capacity of the soil and base to treat them. A liner may also be used if the depth to bedrock or to the water table is only a few feet (3 feet). By storing water for a time in the base and then slowly releasing it through pipes, the design behaves like an underground detention pond. In other cases, the soil of the sub-base may be stabilized to render improved support for vehicular loads. This practice reduces infiltration into the soil to nearly zero. The “no infiltration” option requires the use of geotextile and bedding between the pavers and the open-graded base. In this case, no credit for reduction in flow should be taken in the WWHM. The area is modeled as an impervious surface.
- A common error in designing PICP is assuming that the amount or percent of open surface is equal to the percentage of perviousness. The perviousness and amount of infiltration is dependent on the infiltration rate of the joint filling material, bedding layer, and base materials, not the percentage of the open-surface area. A key consideration is the design permeability of the entire pavement cross section, including the soil subgrade. Because of short-term variations in antecedent conditions and long-term reduction in infiltration capacity, a long-term infiltration rate of 10 percent of the initial rate should be used in design.

#### ***Additional Design Considerations***

- The hydrological performance of PICP should be factored into managing runoff within a larger catchment or watershed. As previously mentioned, Dr. Shackel's Lockpave Pro software includes a hydraulic design program based on SWMM, titled PC-SWMM for

Permeable Pavements. PC-SWMM provides a step by step accounting (conservation of mass) of water movement through the permeable pavement installation, including storm detention, overland flow, infiltration, subsurface storage, and subsurface drainage. If this program is included within a SWMM model that gains Ecology approval as an alternative continuous runoff model, it may be used to estimate the flow benefits of PICP.

- More sophisticated methods for calculating infiltration and exfiltration with a free-draining base or partial exfiltration by drainage pipes, and no infiltration with an impermeable liner and drainpipes are listed in the reference section.

*Storm runoff volumes:* A storm drainage system should be designed to remove storm water within certain time limits and physical constraints. The rate of runoff is influenced by the intensity and duration of rainfall, the type and moisture condition of the base and soil at the time of rainfall, the slope of the surface, the permeability of fill material in drainage voids on the pavement surface, and the drainage voids in the pavement surface itself. Acceptable methods for calculating runoff volumes for treatment and/or flow control purposes are discussed in Volume III of the Surface Water Manual.

*Protection against flooding from extreme storm events:* Drainage pipes may be built into the open-graded base to handle overflow conditions from extreme rainfall. If this is done, the permeable pavement credit in the WWHM should not be turned on. An added measure of protection could include an overflow area or drainage swale designed to handle overflows from an adjacent pervious parking lot.

*Design for water quality:* The type of soil subgrade affects the pollution reduction capabilities of infiltration areas. Unfortunately, many clay soils that are effective pollutant filters do not have sufficiently high infiltration rates or bearing capacity when saturated, and cannot be used under infiltration areas subject to vehicular loads. However, a layer of sand could be placed under the open-graded base to filter and treat pollutants prior to their release into a stream or storm sewer. This would be especially effective with soils that have little treatment capacity. A sand filtering system could also be implemented for filtering runoff from adjacent impervious surfaces.

### **Collection Systems**

- A collection system may be necessary for collecting water from the drainage layer and conveying it to suitable outlets for further treatment or release. If this is done, the permeable pavement credit option in the WWHM should not be turned on. Factors in designing the collection system include the collection system drainage capacity, the location and depth of the collectors and their outlets, the type of collection system to be utilized, and filter protection to provide sufficient drainage capacity and to prevent flushing of the drainage aggregate into the collection system.

- Types of edge drains include the traditional perforated or slotted pipe underdrains, prefabricated geocomposite fin drains, geotextile-wrapped underdrains, and geotextile-socked perforated pipes (see Figure 5.14).

The selection of the type of collection system depends on soil conditions at the site, the function of the collection system (i.e., to be temporary storage or to be a medium for water to pass through), construction feasibility, and economic considerations. Local geotextile suppliers can provide more information on subdrainage designs.

### **Construction Criteria**

Experienced contractors who hold a current Basic Level Certificate in the ICPI Contractor Certification Program must perform installation. Contractors holding this certification have been instructed and tested on knowledge of interlocking concrete pavement construction. Construction guidelines are provided in ICPI Tech Spec 2, Construction of Interlocking Concrete Pavements, ICPI Tech Spec No. 9, Guide Specification for the Construction of Interlocking Concrete Pavement, ICPI Tech Spec 10, Application Guide for Interlocking Concrete Pavements, and Zollinger et al. (1998).

PICP typically consists of a soil subgrade, an aggregate base, bedding sand, concrete pavers, edge restraints, and drainage. Geotextiles are sometimes used under the base, over fine, moist subgrade soils to extend the life of the base and reduce the likelihood of deformation.

Preventing and diverting sediment from entering the base and pavement surface during construction must be the highest priority. Preventing muddy construction equipment from entering the area, installing silt fences, and using temporary drainage swales to divert runoff away from the site make a significant difference in keeping the pavement infiltrating well. Practices intended to prevent clogging should be included in the construction drawings and specifications.

Existing pedestrian paths should be studied and defined before a parking lot or plaza is constructed. Vehicle lands, parking spaces, and pedestrian paths as well as spaces for handicapped persons can be delineated with solid concrete pavers.

### **Soils, Geotextile and Drain Pipes**

- Prior to placing the base, the soil subgrade should be compacted to at least 95 percent of standard Proctor density (per ASTM D 698) for pedestrian areas and to a minimum of 95 percent modified Proctor density (per ASTM D 1557) for vehicular applications. Compaction will reduce infiltration rates but is necessary in most applications for increased structural stability. Some soils may not achieve these recommended minimum levels of density. These soils may have a low bearing capacity or be continually wet. If they are under a base that will receive constant vehicular traffic, the soils may need to be stabilized or have drainage designed to remove excess water.

- Geotextiles are used in all permeable pavement applications. Specifications and minimum physical requirements for geotextiles suited to separation and drainage can be found in the reference section. For vehicular applications, high-quality fabric should be specified that resists the puncturing by coarse, angular aggregate from compaction during construction and from repeated wheel loads during its service life.
- Bases should have their sides and bottoms wrapped in geotextile. For open-graded bases, there should be a 12-inch length placed over the compacted No. 8 aggregate along the perimeter. Geotextile should be used between bedding sand and the No. 8 aggregate base to prevent loss of bedding sand into the surface of the larger No. 8 material.
- Partial or no infiltration designs require pipes to handle storage and outflow from design storms and those from overflow conditions.

### **Open-Graded Aggregate Bases**

- A test section is required for monitoring the aggregate during compaction to determine the settlement of the pavement section. After application of the geotextile, No. 57 base material should be spread in 4- to 6-inch lifts and compacted with a vibratory roller at approximately 1,200 times per minute. At least 4 passes should be made with a minimum 10-ton steel drum roller. The crushed stone should be kept moist during compaction, but water should be kept from wetting the soil subgrade.
- When the base has been compacted, a 3-inch thick layer of leveling course (moist No. 8 crushed stone) is applied to the top surface and pressed into the top of the No. 57 with at least 4 passes of a 10-ton vibratory roller. The No. 8 should be moist in order to facilitate movement into the No. 57.
- After the No. 8 is compacted a 3/4 to 1-inch thick layer is loosened evenly across its surface. The pavers are placed on this loosened layer and compacted with a plate compactor. For concrete units 3 1/8 to 4-inch thick, the plate compactor should exert a minimum 5,000 lbf at 75 to 90 Hz. For thicker concrete units, the compactor should exert at least 6,800 lbf.
- The joints or openings are filled with No. 8 material and the paving units are compacted again. Excess stone is removed by sweeping.
- The concrete pavers should be applied immediately after the base and leveling layers have been placed in order to prevent or reduce the chance of construction equipment passing over the base and contaminating it with sediment. Equipment drivers should avoid rapid acceleration, hard braking, or sharp turning on the compacted drainage layer.

### **Stabilized Bases**

- Open-graded bases may be stabilized with asphalt prior to placement. It should be used on the No. 57 layer and not on the No. 8 layer. The use of asphalt will likely reduce the storage capacity of the base, but stabilization may be necessary in weak soils—those subject to frost heave or under high loads.
- To maintain high void space, only enough asphalt to coat the aggregate is required. This is usually 2 to 2 ½ percent asphalt by weight of the aggregate. The asphalt grade should be AC20 or higher.
- Asphalt-stabilized base will need to be compacted at temperatures lower than normal for asphalt pavement. In most cases, the asphalt should cool to less than 200° F before starting compaction.

*Edge restraints:* ICPI Tech Spec 3, Edge Restraints for Interlocking Concrete Pavements provides guidance on selection of edge restraints for pavement construction with dense-bases. Recommended edge restraints for permeable interlocking concrete pavements on an open-graded base are cast-in-place and precast concrete. Manufacturers of edge restraints fastened by metal spikes should be consulted as to the suitability of their edge restraint systems on open-graded bases subject to pedestrian or vehicular traffic.

*Bedding sand:* As with all interlocking pavements, the gradation of the bedding sand should conform to ASTM C 33 or CSA A23.1. Limestone screenings or stone dust must never be used. The thickness of the bedding sand should be between 1 and 1 1/2 inches and screened to a consistent thickness.

### **Paver Installation**

- PICP concrete pavers are typically installed level to maximize infiltration. Installation can be done by hand or with mechanical equipment. Mechanized installation may be a cost-efficient means to install the units and will reduce the installation time. ICPI Tech Spec 11, Mechanized Installation of Interlocking Concrete Pavements provides detailed information on mechanical installation.
- Like solid pavers, permeable pavers are vibrated into the bedded material with a high frequency (75-90 Hz), low-amplitude plate compactor. The machine should have a minimum centrifugal compaction force of at least 5,000 lbf for settling units 3 1/8 to 4 inches thick. Thicker units will require equipment capable of at least 6,800 lbf. Units should be cut to fill any spaces along the edges prior to compaction. All installed units should be compacted into the bedding sand or No. 8 aggregate and joints filled with the appropriate material at the end of the day.
- The pavers are again compacted.

### ***Operation and Maintenance***

Infiltration areas can become clogged with sediment over time, thereby decreasing storage capacity and slowing their infiltration rate. The rate of sedimentation depends on the amount of traffic and other sources that wash sediment into the joints, base, and soil. Since the pavement is detaining runoff with sediments, there may be a need to remove and replace the base material when the infiltration is reduced to where the pavement is no longer performing its job in storing and exfiltrating water.

Economics may prevent this extent of hydrological rehabilitation to the pavement. The best way to ensure enduring infiltration is to prevent sediment from entering the pavement. A well-designed and maintained pavement can be expected to last from 15 to 25 years. Depending on drainage performance, the base may need to be excavated, sediment removed, and clean aggregate reinstated with the same concrete pavers.

The lifetime of the pavement can be extended by pre-treating runoff that originates offsite, such as runoff originating from adjacent impervious surfaces. Filter areas or small basins used to capture sediment in urban runoff will reduce the potential for clogging of the PICP. They will also substantially extend the number of years before removal and replacement with clean sand and aggregate are necessary. The length of years added to the infiltrative performance of the pavement may be worth the additional space and initial expenditure.

Permeability has been successfully restored in some PICP projects using conventional street-sweeper equipment with vacuums, water, and brushes.

All PICP should have an observation well to monitor the amount of sediment in the water held in the base. The well is typically a 4 to 6-inch diameter capped pipe that can be uncovered and water samples drawn from time to time.

Snow can be plowed from pavers as with as other pavement. If a unit cracks from soil or base settlement, it should be removed and replaced. Likewise, the same units can be reinstated after repairs to the base, drainpipes, liners, or to underground utilities.

## Resource Material

The following references provide detailed information on the technical design and construction of PICP.

AASHTO-AGC-ARTBA Joint Committee. 1990. Guide Specifications and Test Procedures for Geotextiles. Task Force 25 Report. American Association of State Highway and Transportation Officials, Washington DC.

American Association for State Highway and Transportation Officials. 1993a. Designation T-215, Standard Methodology of Test for Permeability of Granular Soils (Constant Head). In Standard Specifications for Transportation Material and Methods of Sampling and Testing, 16<sup>th</sup> Edition, Part II Tests, Washington, DC.

American Association for State Highway and Transportation Officials. 1993b. Standard Method of Test for the Moisture-Density Relations of Soils Using a 5.5-lb [2.5 kg] Rammer and a 12 in [305 mm] Drop, AASHTO Designation T-99. *In* Standard Specifications for Transportation Material and Methods of Sampling and Testing, 16<sup>th</sup> Edition, Part II Tests. American Association for State Highway and Transportation Officials, Washington, DC.

American Association for State Highway and Transportation Officials. 1993c. Standard Method of Test for the Relations of Soils Using a 10-lb Rammer and an 18-in Drop, AASHTO Designation T-180. *In* Standard Specifications for Transportation Material and Methods of Sampling and Testing, 16<sup>th</sup> Edition, Part II Tests, American Association for State Highway and Transportation Officials, Washington, DC.

American Association for State Highway and Transportation Officials. 1993d. AASHTO Designation T-193. *In* Standard Specifications for Transportation Material and Methods of Sampling and Testing, 16<sup>th</sup> Edition, Part II Tests, Washington, DC.

American Society for Testing and Materials. 1996. ASTM C 33, Standard Specification for Concrete Aggregates. *In* Annual Book of ASTM Standards, Vol. 04.02. Conshohocken, Pennsylvania.

American Society for Testing and Materials. 1998. ASTM D 698, Standard Test Method for Laboratory Compaction Characteristics of Soil Using Standard Effort (12,400 ft-lbf/ft<sup>3</sup> (600 kN-m/m<sup>3</sup>)). *In* Annual Book of ASTM Standards, Vol. 04.08. American Society for Testing and Materials, Conshohocken, Pennsylvania.

American Society for Testing and Materials. 1991. ASTM C 936, Standard Specification for Solid Concrete Interlocking Paving Units. *In* Annual Book of ASTM Standards, Vol. 04.05., Conshohocken, Pennsylvania.

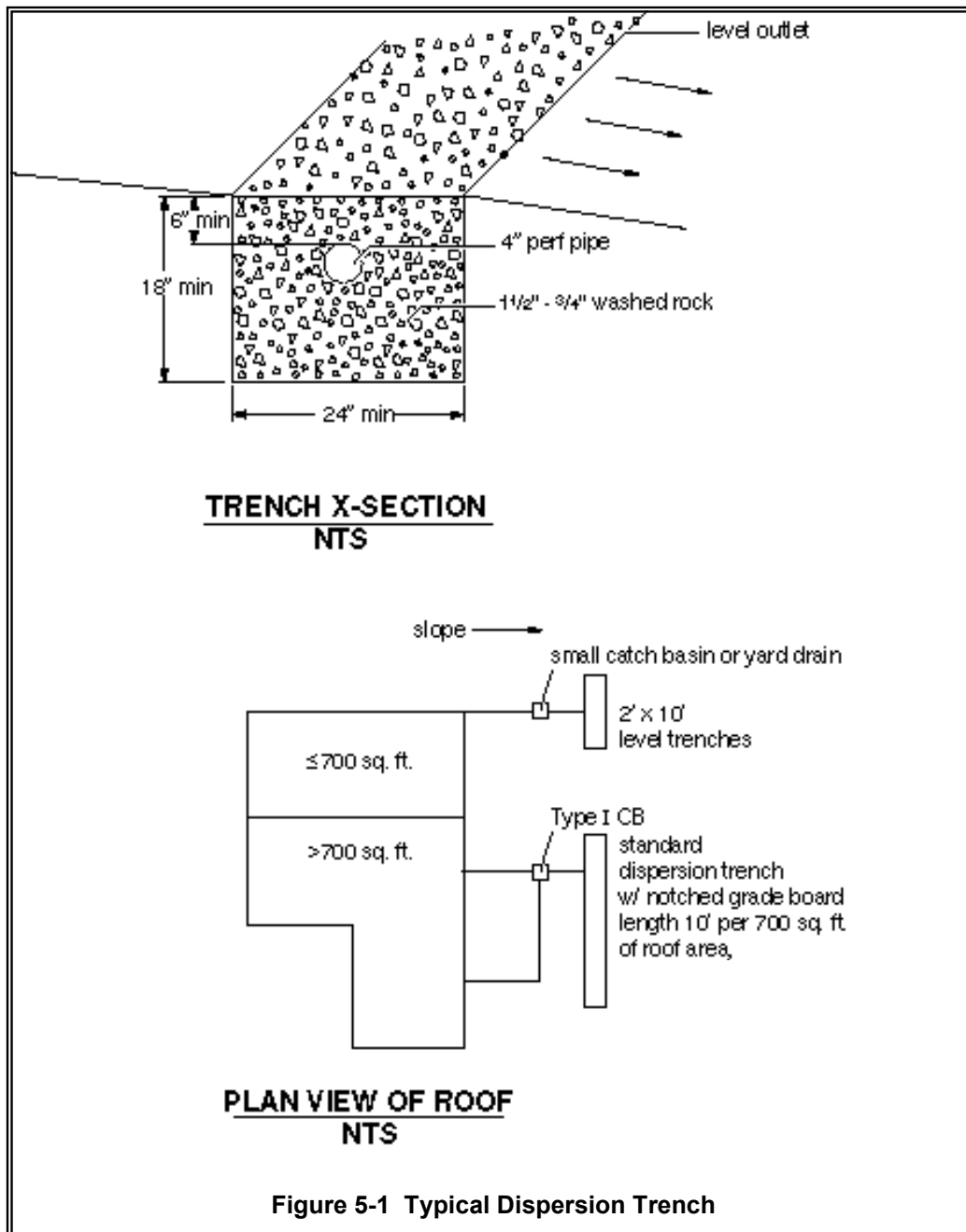
American Society for Testing and Materials. 1998. ASTM D 1557, Standard Test Method for Laboratory Compaction Characteristics of Soil Using Modified Effort. *In* Annual Book of ASTM Standards, Vol. 04.08, Conshohocken, Pennsylvania.

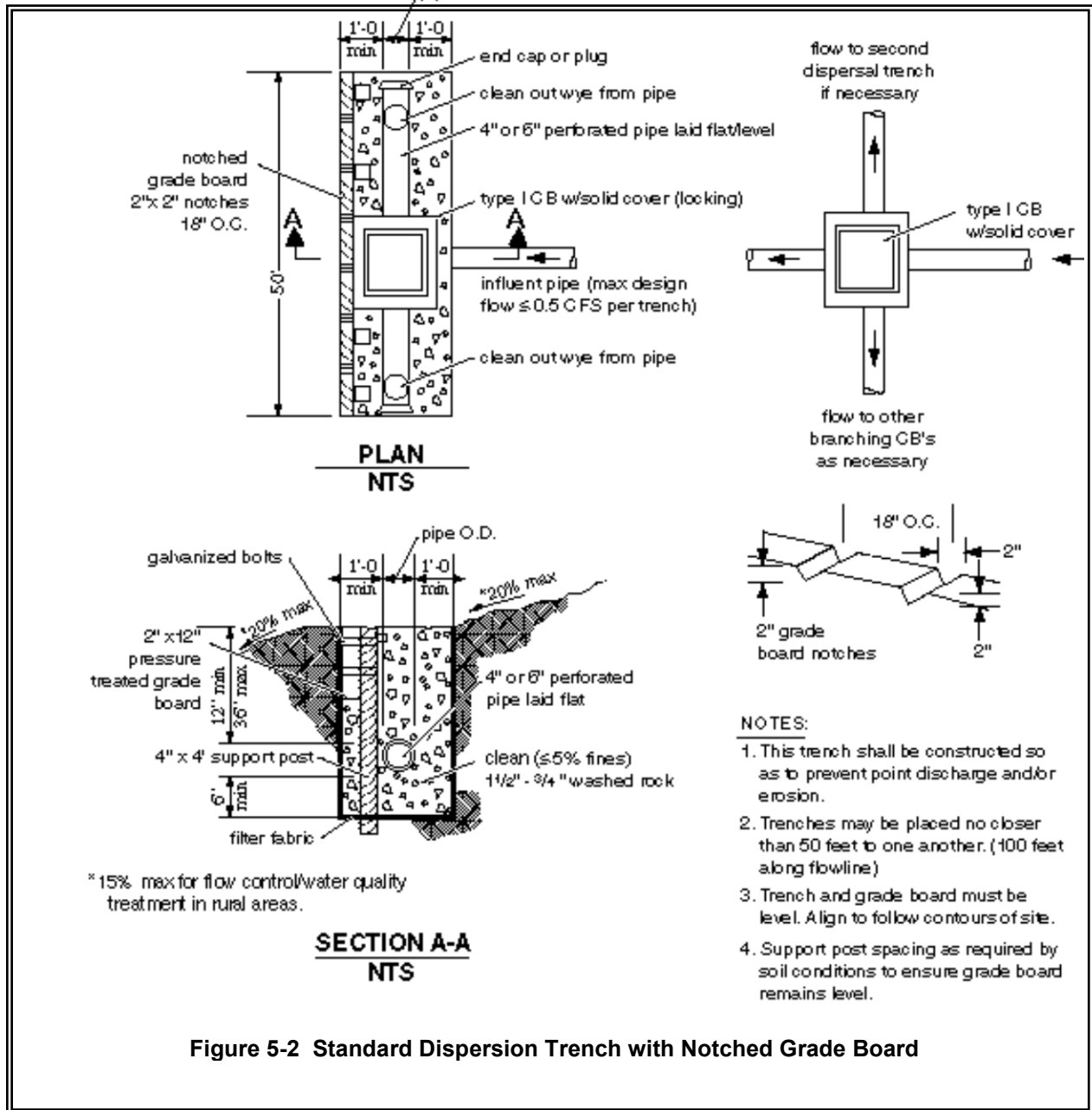
American Society for Testing and Materials. 1998. ASTM D 1883, Standard Test Method for CBR (California Bearing Ratio) of Laboratory-Compacted Soil. *In* Annual Book of ASTM Standards, Vol. 04.08, Conshohocken, Pennsylvania.



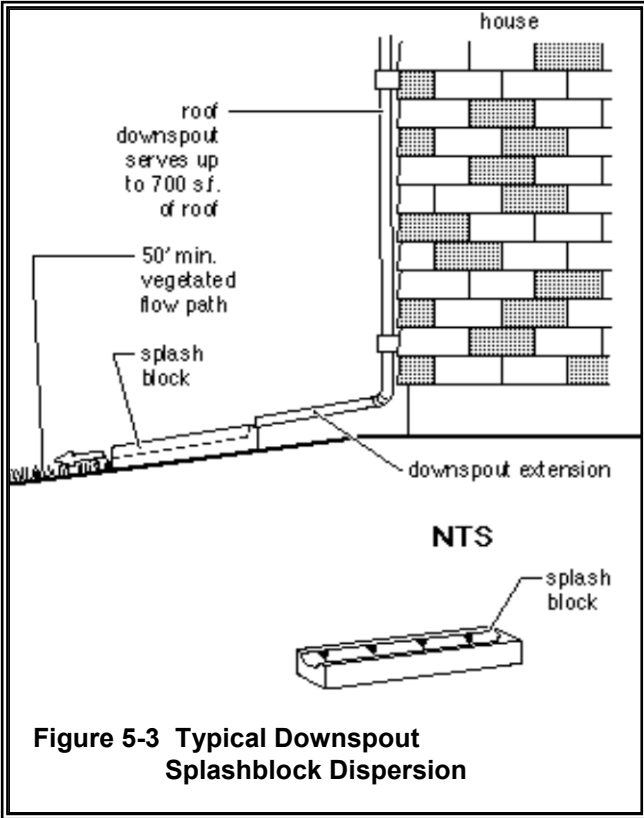
- American Society for Testing Materials. 1998. ASTM D 2434, Standard Test Methodology for Permeability of Granular Soils. *In Annual Book of ASTM Standards*, Vol. 04.08, Conshohocken, Pennsylvania.
- American Society for Testing and Materials. 1998. ASTM D 2487, Standard Classification of Soils for Engineering Purposes (Unified Soil Classification System). *In Annual Book of ASTM Standards*, Vol. 04.08. American Society for Testing and Materials, Conshohocken, Pennsylvania.
- American Society for Testing and Materials. 1995. ASTM D 2940, Standard Specification for Graded Aggregate Material for Bases or Subbases for Highway or Airports. *In Annual Book of ASTM Standards*, Vol. 04.03. American Society for Testing and Materials, Conshohocken, Pennsylvania.
- Asphalt Institute. 1993. Soils Manual for the Design of Asphalt Pavement Structures, MS-10. Fifth Edition, Lexington, Kentucky.
- Asphalt Institute. 1989. The Asphalt Handbook. MS-4, Lexington, Kentucky.
- Barksdale, R.D., editor. 1991. The Aggregate Handbook, National Stone Association, Washington, DC.
- Canadian Standards Association. 1990. CSA A23.1-M90, Concrete Materials and Methods of Concrete Construction. Canadian Standards Association, Rexdale, Ontario.
- Canadian Standards Association. 1995. A231.2-95, Precast Concrete Pavers. Rexdale, Ontario, 1995.
- Canadian Standards Association. 1999. A231.1-99, Precast Concrete Paving Slabs. Rexdale, Ontario.
- Cao, S.L., Poduska, D. and D.G. Zollinger. 1998. Drainage Design and Rutting Performance Guidelines for Permeable Pavement. Texas A & M University, College Station, Texas.
- Cedergren, H.R. 1987. Drainage of Highway and Airfield Pavements. Krieger Publishing Company, Malabar, Florida.
- Claytor, R.A., and T.R. Schueler. 1996. Design of Storm water Filtering Systems. Center for Watershed Protection, Silver Spring, Maryland.
- Debo, T.N., and A.J. Reese. 1995. Municipal Storm Water Management. Lewis Publishers. CBC Press, Boca Raton, Florida.
- Ferguson, B.K. 1994. Stormwater Infiltration. Lewis Publishers. CBC Press, Boca Raton, Florida.
- Goforth, G.F., Danuas, E.V. and J.B. Rawhide. 1983. Stormwater Hydrological Characteristics of Porous and Conventional Paving Systems. Municipal Environmental Research Laboratory, Office of Research and Development. US Environmental Protection Agency, Cincinnati, Ohio.

- Interlocking Concrete Pavement Institute. 1995a. ICPI Tech Spec 1, Glossary of Terms used in the Production, Design, Construction and Testing of Interlocking Concrete Pavement. Interlocking Concrete Pavement Institute, Washington DC.
- Interlocking Concrete Pavement Institute. 1999. ICPI Tech Spec 2, Construction of Interlocking Concrete Pavements. Interlocking Concrete Pavement Institute, Washington DC.
- Interlocking Concrete Pavement Institute. 1995b. ICPI Tech Spec 3, Edge Restraints for Interlocking Concrete Pavement. Interlocking Concrete Pavement Institute, Washington DC.
- Interlocking Concrete Pavement Institute. 1995c. ICPI Tech Spec 4, Structural Design of Interlocking Pavements for Roads and Parking Lots. Interlocking Concrete Pavement Institute, Washington DC.
- Interlocking Concrete Pavement Institute. 1996. ICPI Tech Spec 6, Reinstatement of Interlocking Concrete Pavements. Interlocking Concrete Pavement Institute, Washington DC.
- Interlocking Concrete Pavement Institute. 1999b. ICPI Tech Spec 9, Guide Specification for the Construction of Interlocking Concrete Pavement. Interlocking Concrete Pavement Institute, Washington DC.
- Interlocking Concrete Pavement Institute. 1998.a ICPI Tech Spec 10, Application Guide for Interlocking Concrete Pavements. Interlocking Concrete Pavement Institute, Washington DC.
- Interlocking Concrete Pavement Institute. 1998b. ICPI Tech Spec 11, Mechanical Installation of Interlocking Concrete Pavements. Interlocking Concrete Pavement Institute, Washington DC.
- KPFF Consulting Engineers. 2000. Eco-Stone Permeable Pavement System Hydraulic Analysis (DRAFT). Project No. 99493. Prepared for Mutual Materials, Seattle, Washington.
- Rollings, R.S. and M.P. Rollings. 1999. SF-Rima: A Permeable Paving Stone System. SF Concrete Technologies, Mississauga, Ontario.
- Rollings, R.S. and M.P. Rollings. 1993. Design Considerations for the Uni Eco-Stone Concrete Paver. Uni-Group USA, Palm Beach Gardens, Florida.
- Shackel, B. 1999. Lockpave Pro 2000, Structural Design of Interlocking Concrete Block Pavements Software Program. Uni-Group USA, Palm Beach, Florida.
- Zollinger, D.G., Cao, S.L., and D. Poduska. 1998. Drainage Design and Performance Guidelines for Uni Eco-Stone Permeable Pavement. The Department of Civil Engineering, Texas A & M University. Uni-Group, U.S.A., Palm Springs, Florida.





**Figure 5-2 Standard Dispersion Trench with Notched Grade Board**



**Figure 5-3 Typical Downspout  
Splashblock Dispersion**

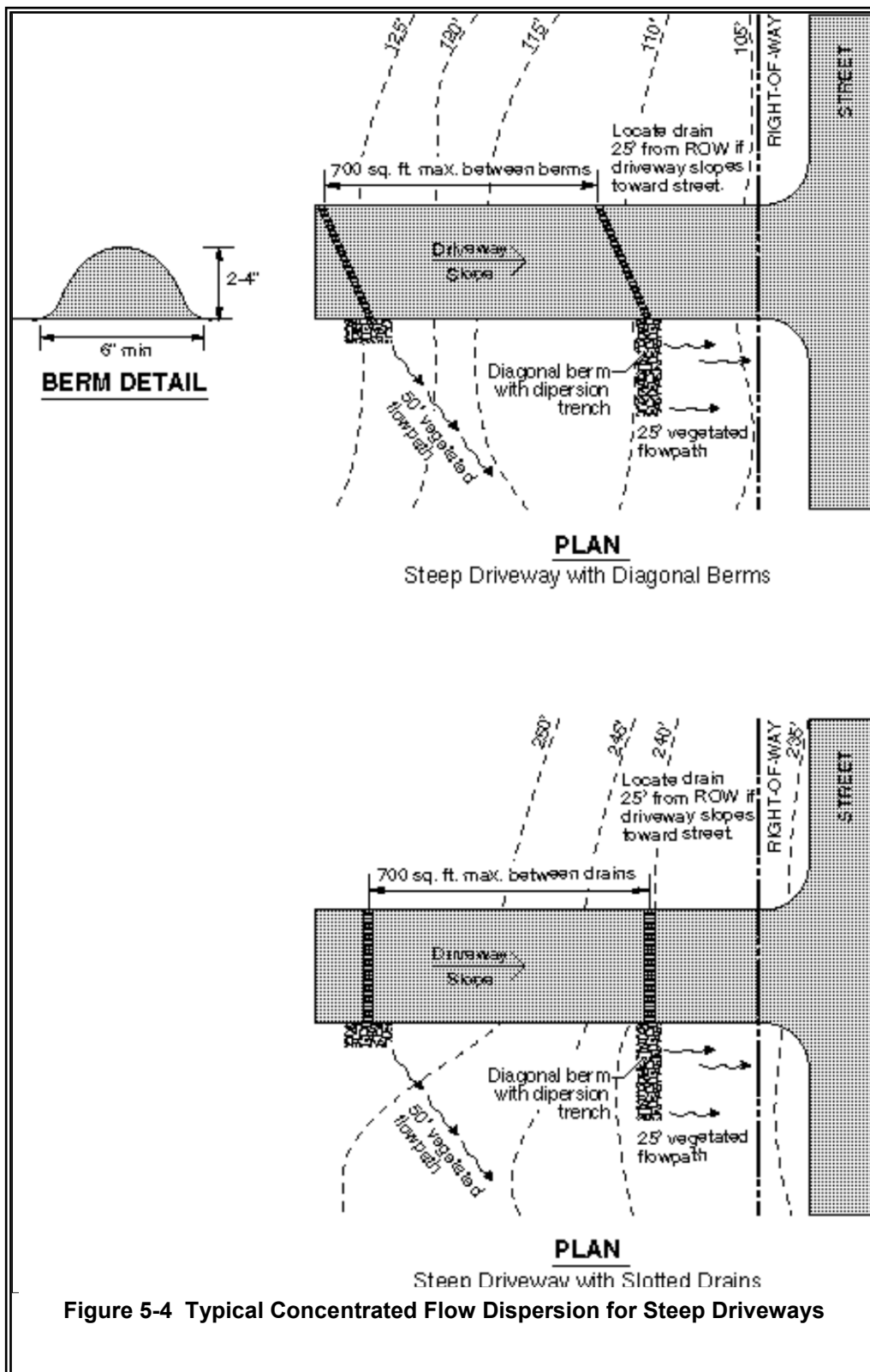


Figure 5-4 Typical Concentrated Flow Dispersion for Steep Driveways

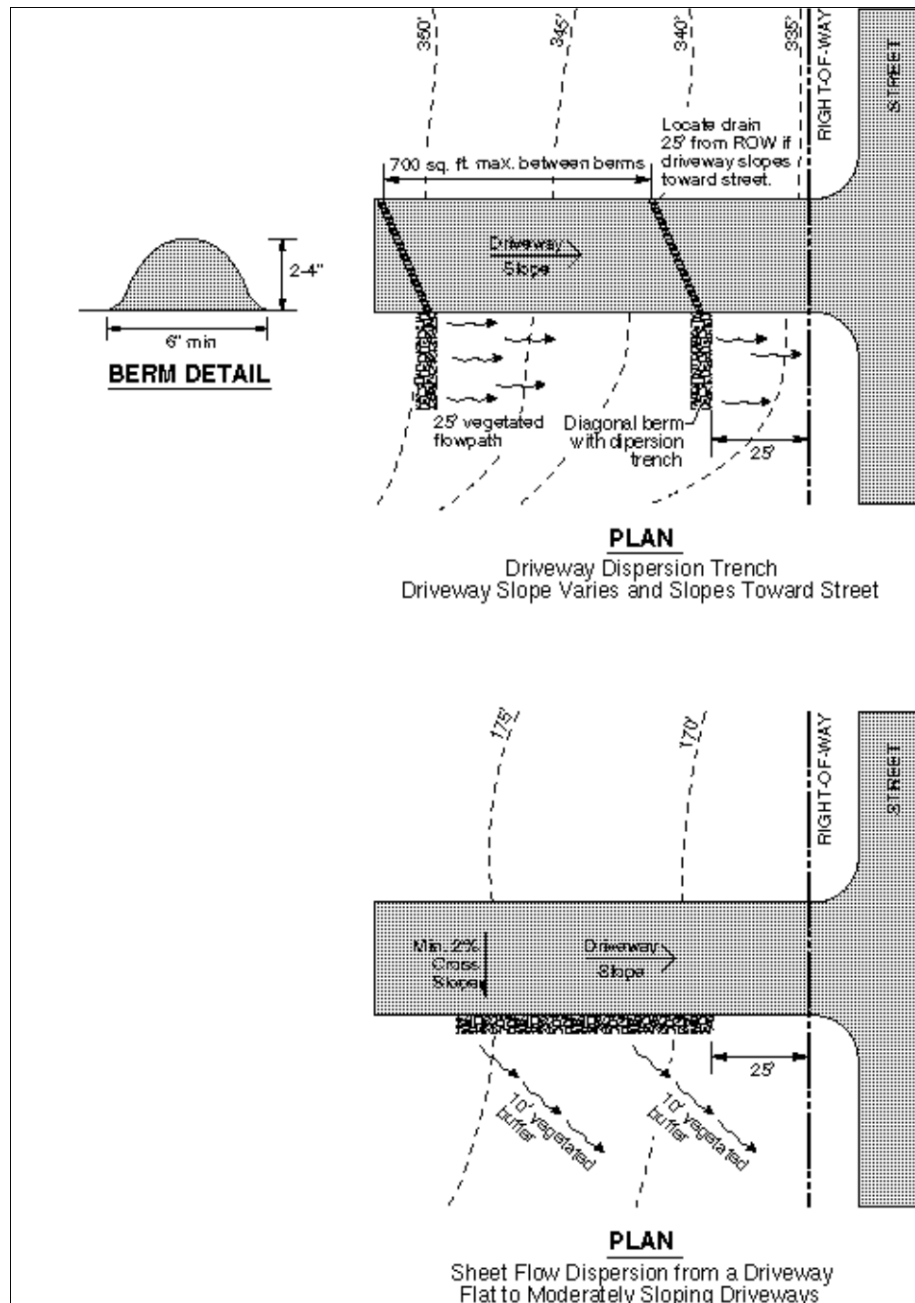
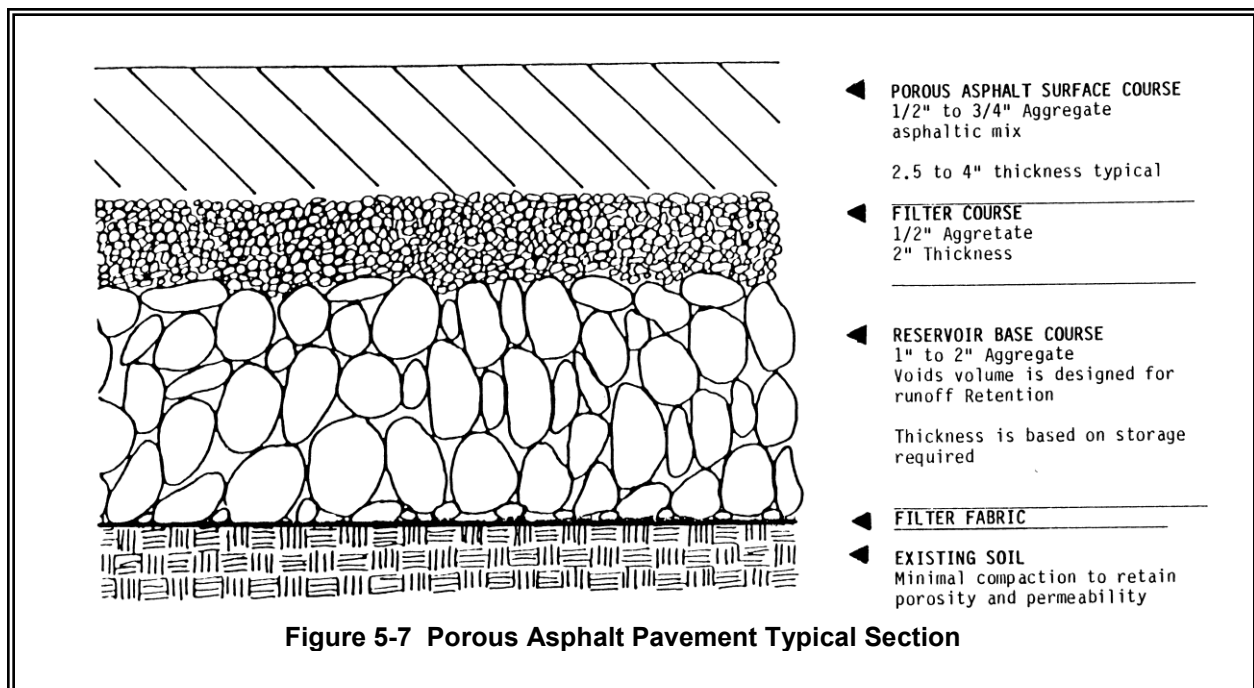
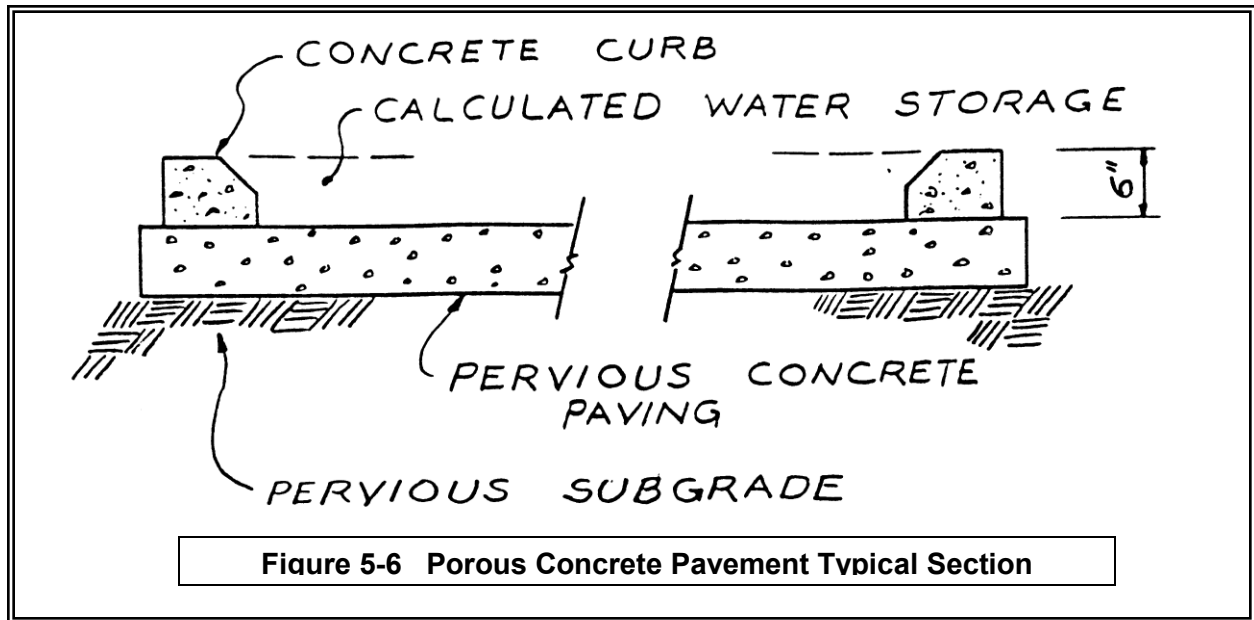
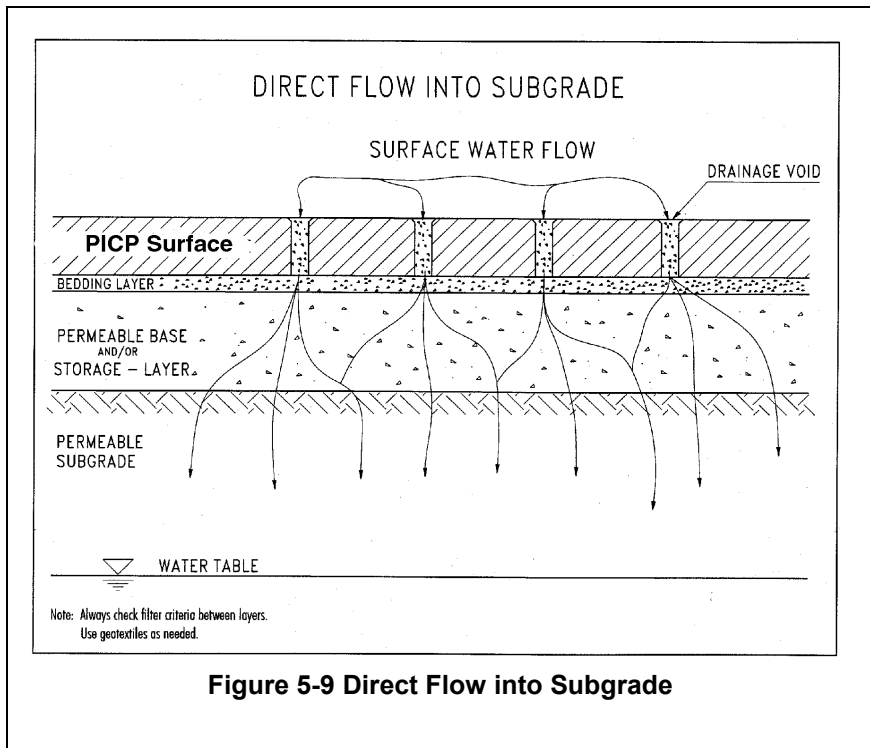
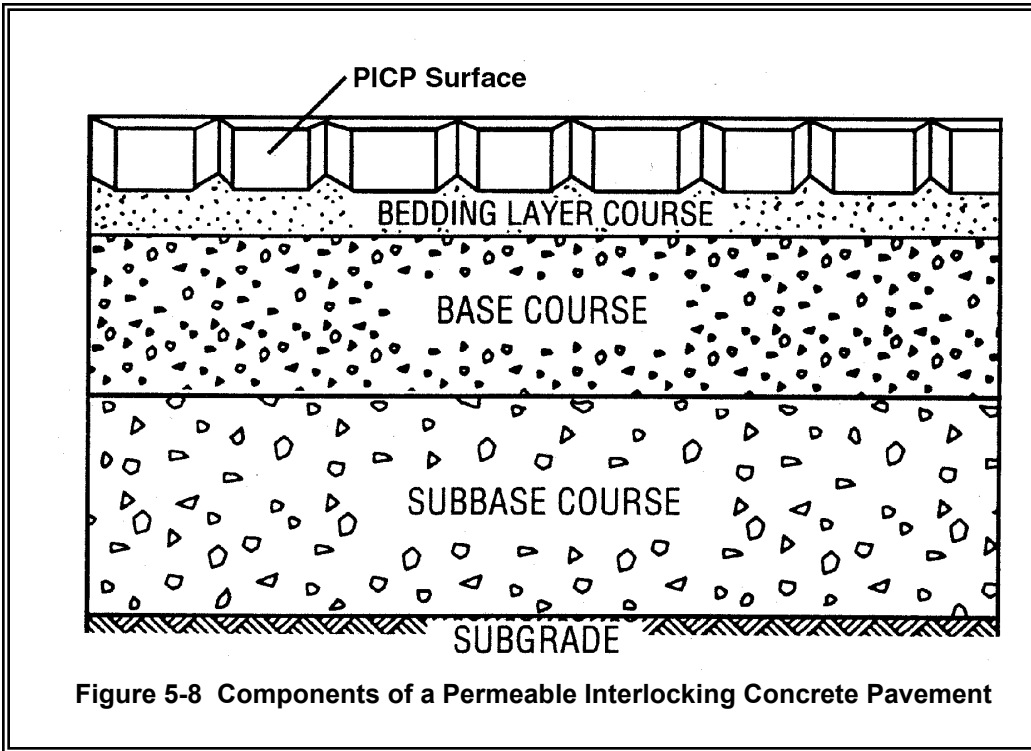
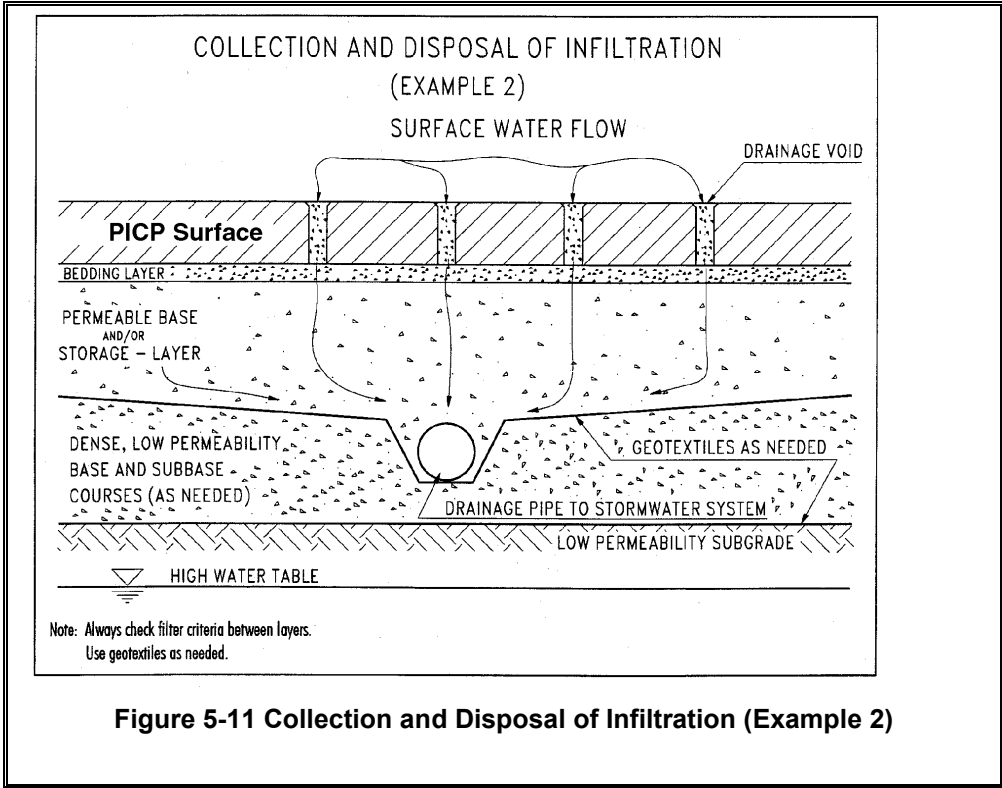
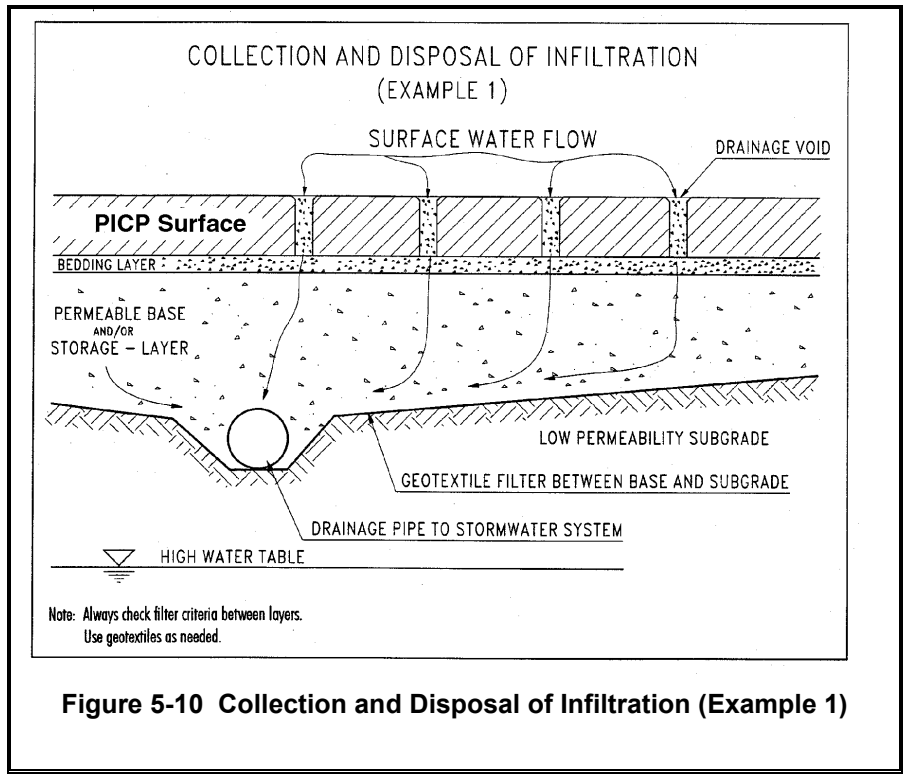


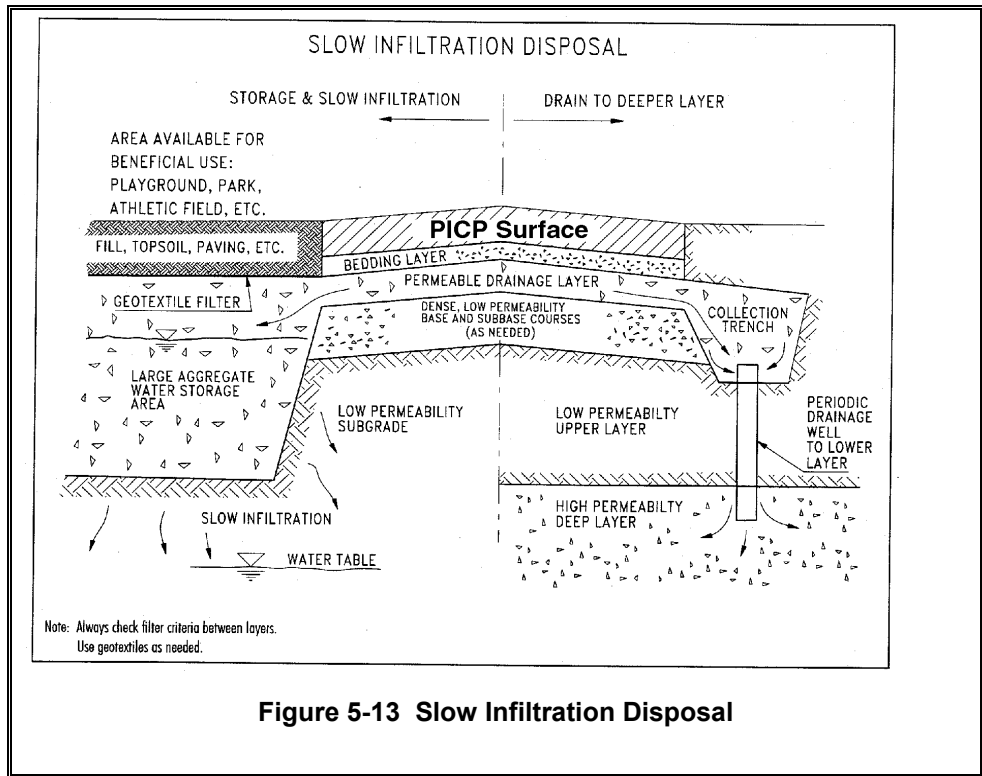
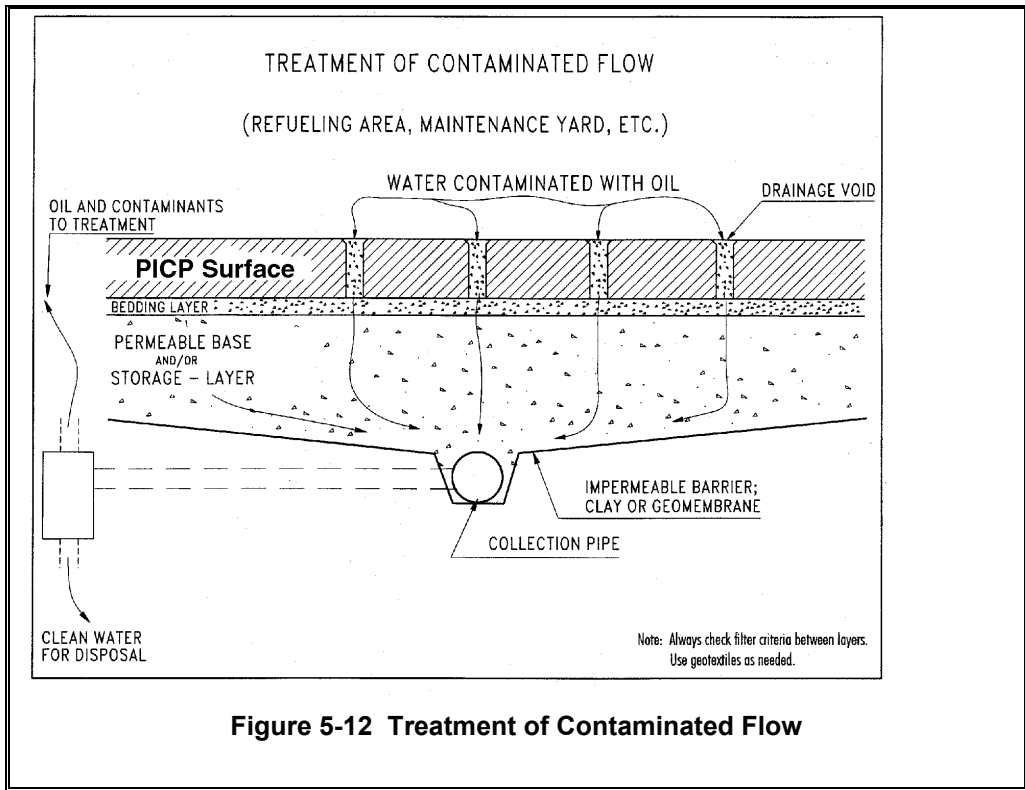
Figure 5-5 Sheet Flow Dispersion for Driveways

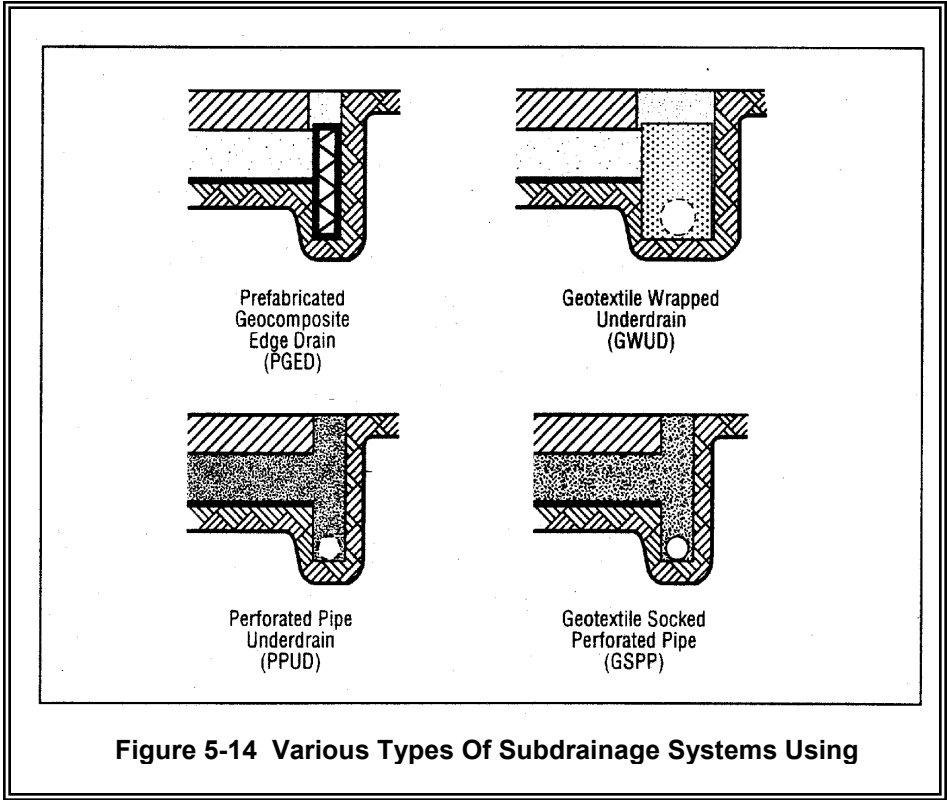












# Chapter 6 - Pretreatment

---

## 6.1 Purpose

This chapter presents the methods that may be used to provide pretreatment prior to basic or enhanced runoff treatment facilities. Pretreatment must be provided in the following applications:

- For sand and media filtration and infiltration BMPs to protect them from excessive siltation and debris;
- Where the basic treatment facility or the receiving water may be adversely affected by non-targeted pollutants (e.g., oil), or may be overwhelmed by a heavy load of targeted pollutants (e.g., suspended solids).

## 6.2 Application

Presettling basins are a typical pretreatment BMP used to remove suspended solids. All of the basic runoff treatment facilities may also be used for pretreatment to reduce suspended solids. Catchbasin inserts may be appropriate in some circumstances to provide oil or TSS control, depending on the type of insert. Some of the manufactured storm drain structures presented in Chapter 12 may also be used for pretreatment for oil or TSS reduction.

A detention pond sized to meet the flow control standard in Volume I may also be used to provide pretreatment for suspended solids removal.

## 6.3 Best Management Practices (BMPs) for Pretreatment

This Chapter has only one BMP - BMP T6.10 for presettling basins.

## **BMP T6.10 Presettling Basin**

### ***Purpose and Definition***

A Presettling Basin provides pretreatment of runoff in order to remove suspended solids, which can impact other runoff treatment BMPs.

### ***Application and Limitations***

Runoff treated by a Presettling Basin may not be discharged directly to a receiving water; it must be further treated by a basic or enhanced runoff treatment BMP.

### ***Design Criteria***

1. A presettling basin shall be designed with a wetpool. The treatment volume shall be at least 30 percent of the total volume of runoff from the 6-month, 24-hour storm event.
2. If the runoff in the Presettling Basin will be in direct contact with the soil, it must be lined per the liner requirement in Section 4.4.
3. The Presettling Basin shall conform to the following:
  - a) The length-to-width ratio shall be at least 3:1. Berms or baffles may be used to lengthen the flowpath.
  - b) The minimum depth shall be 4 feet; the maximum depth shall be 6 feet.
4. Inlets and outlets shall be designed to minimize velocity and reduce turbulence. Inlet and outlet structures should be located at extreme ends of the basin in order to maximize particle-settling opportunities.

### ***Site Constraints and Setbacks***

Site constraints are any manmade restrictions such as property lines, easements, structures, etc. that impose constraints on development. Constraints may also be imposed from natural features such as requirements in the Tacoma Municipal Code. These should also be reviewed for specific application to the proposed development. For Setback Requirements and Site Constraints See Section 4.3.1 and 4.3.2.

# Chapter 7 - Infiltration and Bio-infiltration Treatment Facilities

---

## 7.1 Purpose

This Chapter provides site suitability, design, and maintenance criteria for infiltration treatment systems. Infiltration treatment Best Management Practices (BMPs) serve the dual purpose of removing pollutants (TSS, heavy metals, phosphates, and organics) from storm water and recharging aquifers.

A storm water infiltration treatment facility is an impoundment, typically a basin, trench, or bio-infiltration swale whose underlying soil removes pollutants from storm water. The infiltration BMPs described in this chapter include:

BMP T7.10 Infiltration basins  
BMP T7.20 Infiltration trenches  
BMP T7.30 Bio-infiltration swales

Infiltration treatment soils must contain sufficient organic matter and/or clays to sorb, decompose, and/or filter storm water pollutants. Pollutant/soil contact time, soil sorptive capacity, and soil aerobic conditions are important design considerations.

The earlier sections of this Chapter provide information regarding site criteria, infiltration rates, site suitability, and guidance of a general nature for all of these BMPs. Later in the Chapter, detailed additional design criteria and considerations are provided for each specific BMP. Also, design requirements for infiltration facilities meeting Minimum Requirements #7: Flow Control, are not found in this Volume, but are found in Volume III.

## 7.2 Application

These infiltration and bio-infiltration treatment measures are capable of achieving the performance objectives cited in Chapter 3 for specific treatment menus. In general, these treatment techniques can capture and remove or reduce the target pollutants to levels that:

- Will not adversely affect public health or beneficial uses of surface and groundwater resources, and
- Will not cause a violation of groundwater quality standards

Infiltration treatment systems are typically installed:

- As off-line systems, or on-line for small drainages.
- As a polishing treatment for street/highway runoff after pretreatment for TSS and oil.
- As part of a treatment train.
- As retrofits at sites with limited land areas, such as residential lots, commercial areas, parking lots, and open space areas.
- With appropriate pretreatment for oil and silt control to prevent clogging. Appropriate pretreatment devices include a pre-settling basin, wet pond/vault, biofilter, constructed wetland, media filter, and oil/water separator.

An infiltration basin is preferred, where applicable, and where a trench or bio-infiltration swale cannot be sufficiently maintained.

## **7.3 General Considerations**

Discussed below are several considerations common to infiltration and bio-infiltration treatment.

### **7.3.1 Site Characterization Criteria**

One of the first steps in siting and designing infiltration treatment facilities is to conduct a characterization study. Information gathered during initial geotechnical investigations can be used for the site characterization. Some of the key data and issues to be characterized include the following:

#### **Surface Features Characterization:**

- Topography within 500 feet of the proposed facility.
- Anticipated site use (street/highway, residential, commercial, high-use site).
- Location of water supply wells within 500 feet of proposed facility.
- Location of groundwater protection areas and/or 1, 5 and 10-year time of travel zones for municipal well protection areas.
- A description of local site geology, including soil or rock units likely to be encountered, the groundwater regime, and geologic history of the site.

#### **Subsurface Characterization**

- Subsurface explorations (test holes or test pits) to a depth below the base of the infiltration facility of at least 5 times the maximum design depth of ponded water proposed for the infiltration facility,
- Test holes or test pits explorations shall be conducted during the wet season (December 1<sup>st</sup> through April 30<sup>th</sup>) to provide accurate groundwater saturation and groundwater information.



- Continuous sampling (representative samples from each soil type and/or unit within the infiltration receptor) to a depth below the base of the infiltration facility of 2.5 times the maximum design ponded water depth, but not less than 6 feet.
  - For basins, at least one test pit or test hole per 5,000 ft<sup>2</sup> of basin infiltrating surface (in no case less than two per basin).
  - For trenches, at least one test pit or test hole per 50 feet of trench length (in no case less than two per trench).

*Note: The depth and number of test holes or test pits and samples should be increased if, in the judgment of a licensed engineer with geotechnical expertise (P.E.) or other licensed professional acceptable to the City, the conditions are highly variable and such increases are necessary to accurately estimate the performance of the infiltration system. The exploration program may also be decreased if, in the opinion of the licensed engineer or other professional, the conditions are relatively uniform and the borings/test pits omitted will not influence the design or successful operation of the facility. In high water table sites the subsurface exploration sampling need not be conducted lower than two (2) feet below the groundwater table.*

- Prepare detailed logs for each test pit or test hole and a map showing the location of the test pits or test holes. Logs must include at a minimum, depth of pit or hole, soil descriptions, depth to water, presence of stratification.

*Note: Logs must substantiate whether stratification does or does not exist. The licensed professional may consider additional methods of analysis to substantiate the presence of stratification that will significantly impact the design of the infiltration facility.*

### **Infiltration Rate Determination**

Determine the representative infiltration rate of the unsaturated vadose zone based on field infiltration tests and/or grain size/texture determinations. Field infiltration rates can be determined using the Pilot Infiltration Test (see PIT-Appendix V-B). Such site testing should be considered to verify infiltration rate estimates based on soil size distribution and/or texture. Infiltration rates may also be estimated based on soil grain-size distributions from test pits or test hole samples. This may be particularly useful where a sufficient source of water does not exist to conduct a pilot infiltration test. As a minimum, one soil grain-size analysis per soil stratum in each test hole shall be performed within 2.5 times the maximum design water depth, but not less than 6 feet.

The infiltration rate is needed for routing and sizing purposes and for classifying the soil for treatment adequacy.

## **Soil Testing**

At a minimum, soil characterization for each soil unit (soils of the same texture, color, density, compaction, consolidation and permeability) encountered shall include:

- Grain-size distribution (ASTM D422 or equivalent AASHTO specification).
- Textural class (USDA) (See Figure 7.1).
- Percent clay content (include type of clay, if known).
- Cation exchange capacity (CEC) and organic matter content for each soil type and strata. Where distinct changes in soil properties occur, to a depth below the base of the facility of at least 2.5 times the maximum design water depth, but not less than 6 feet. Consider if soils are already contaminated, thus diminishing pollutant sorptive capacity (for water quality design only).
- For soils with low CEC and organic content, deeper characterization of soils may be warranted (refer to Section 7.3.3 Site Suitability Criteria) (for water quality design only).
- Color/mottling.
- Variations and nature of stratification.

## **Infiltration Receptor**

Infiltration receptor (unsaturated and saturated soil receiving the storm water) characterization should include:

- Installation of groundwater monitoring wells. Use at least three per infiltration facility, or three hydraulically connected surface and groundwater features. This will establish a three-dimensional relationship for the groundwater table, unless the highest groundwater level is known to be at least 50 feet below the proposed infiltration facility. The monitoring wells will:
  - Monitor the seasonal groundwater levels at the site during at least one wet season, and,
  - Consider the potential for both unconfined and confined aquifers, or confining units, at the site that may influence the proposed infiltration facility as well as the groundwater gradient. Other approaches to determine groundwater levels at the proposed site could be considered if pre-approved by the City of Tacoma, and,
  - Determine the ambient groundwater quality, if that is a concern.
- An estimate of the volumetric water holding capacity of the infiltration receptor soil. This is the soil layer below the infiltration facility and above the seasonal high-water mark, bedrock, hardpan, or other low permeability layer. This analysis should be conducted at a conservatively high infiltration rate based on vadose zone porosity, and the water quality runoff volume to be infiltrated. This, along with

an analysis of groundwater movement, will be useful in determining if there are volumetric limitations that would adversely affect drawdown.

- Depth to groundwater table and to bedrock/impermeable layers.
- Seasonal variation of groundwater table based on well water levels and observed mottling.
- Existing groundwater flow direction and gradient.
- Lateral extent of infiltration receptor.
- Horizontal hydraulic conductivity of the saturated zone to assess the aquifer's ability to laterally transport the infiltrated water.
- Impact of the infiltration rate and volume at the project site on groundwater mounding, flow direction, and water table; and the discharge point or area of the infiltrating water. A groundwater mounding analysis should be conducted at all sites where the depth to seasonal groundwater table or low permeability stratum is less than 15 feet and the runoff to the infiltration facility is from more than one acre. The site professional can consider conducting an aquifer test, or slug test and the type of groundwater mounding analysis necessary at the site.

*Note: A detailed soils and hydrogeologic investigation should be conducted if potential pollutant impacts to groundwater are a concern, or if the applicant is proposing to infiltrate in areas underlain by till or other impermeable layers. (Suggested references: "Implementation Guidance for the Ground Water Quality Standards", Department of Ecology, publication 96-2, 1996, and, "Washington State Water Quality Guide," Natural Resources Conservation Service, W. 316 Boone Ave, Spokane, WA 99201-2348).*

### **7.3.2 Design Infiltration Rate Determination**

The representative site infiltration rate must be determined from soil test results, the stratification identified during the site characterization, and/or in-situ field measurements.

Infiltration rates for treatment can be determined using either a correlation to grain size distribution from soil samples, textural analysis, or by in-situ field measurements. Short-term infiltration rates up to 2.4 in./hr represent soils that typically have sufficient treatment properties. Long-term infiltration rates are used for sizing the infiltration pond based on maximum pond level and drawdown time. Long-term infiltration rates up to 2.0 inches per hour can also be considered for treatment if SSC-4 and SSC-6 are met, as defined in Section 7.3.3.

Historically, infiltration rates have been estimated from soil grain size distribution (gradation) data using the United States Department of Agriculture (USDA) textural analysis approach. To use the USDA textural analysis approach, the grain size distribution test must be conducted in accordance with the USDA test procedure (Soil Survey Manual, U.S. Department of Agriculture, October 1993, page 136). This manual only

considers soil passing the #10 sieve (2 mm) (U.S. Standard) to determine percentages of sand, silt, and clay for use in Figure 7.1 (USDA Textural Triangle). However, many soil test laboratories use the ASTM soil size distribution test procedure (ASTM D422), which considers the full range of soil particle sizes, to develop soil size distribution curves. **The ASTM soil gradation procedure must not be used with Figure 7.1.**

### **Three Methods for Determining Long-term Infiltration Rate for Sizing the Infiltration Basin, Trench, or Swale**

For designing the infiltration facility, the site professional should select one of the three methods described below that will best represent the long-term infiltration rate at the site. The long-term infiltration rate should be used for routing and sizing the basin/trench for the maximum drawdown time of 24 hours. It is suggested that Method 1 be used to corroborate and compare the infiltration rate estimates of the other methods, using the appropriate correction factors. Verification testing of the completed facility is strongly encouraged using Site Suitability Criterion (SSC) # 9.

#### *Method 1 — USDA Soil Textural Classification*

Table 7.1 correlates USDA soil texture and infiltration rates for homogeneous soils. It is based on the correlation developed by Rawls, et. al., with minor changes in the infiltration rates based on WEF/ASCE (1998). The infiltration rates provided in Table 7.1 represent short-term conservative rates for homogeneous soils, which should be used for treatment soil suitability determinations. However, these rates do not represent the effects of site variability and long-term clogging due to siltation and biomass buildup in the infiltration facility.

To determine long-term infiltration rates, Ecology's Technical Advisory Committee (TAC) recommends that the short-term infiltration rates be reduced as shown in Table 7.1. A correction factor of 2 to 4 is assigned, depending on the soil textural classification. These correction factors (CF) consider an average degree of long-term facility maintenance, TSS reduction through pretreatment, and site variability in the subsurface conditions (due to a deposit of ancient landslide debris, buried stream channels, lateral grain size variability, etc. that affect homogeneity).

However, these correction factors could be reduced, subject to the approval of the City of Tacoma, under the following conditions:

- For sites with little soil variability,
- Where there will be a high degree of long-term facility maintenance,
- Where specific, reliable pretreatment is employed to reduce TSS entering the infiltration facility.

#### **In no case shall a correction factor less than 2.0 be used.**

Correction factors higher than those provided in Table 7.1 should be considered for situations where: long-term maintenance will be difficult to implement; where little or no pretreatment is anticipated; or, where site conditions are highly variable or uncertain. These situations require the

use of best professional judgment by the site engineer and the approval of the City. An operation and maintenance plan and a financial bonding plan may also be required by the City.

#### *Method 2 — ASTM Gradation Testing at Full Scale Infiltration Facilities*

As an alternative to Table 7.1, recent studies by Massmann and Butchart were used to develop long-term infiltration rates provided in Table 7.2. These studies compare infiltration measurements from full-scale infiltration facilities to soil gradation data developed using the ASTM procedure (ASTM D422). The data that forms the basis for Table 7.2 was from soils that would be classified as sands or sandy gravels. No data was available for finer soils. Therefore, Table 7.2 should not be used for soils with a  $d_{10}$  size (10% passing the size listed) less than 0.05 mm (U.S. Standard Sieve).

The primary source of the data used by Massmann and Butchart was from Wiltsie (1998), who included limited infiltration studies only on Thurston County sites. However, Massmann and Butchart also included limited data from King and Clark County sites in their analysis. This table provides recommended long-term infiltration rates that have been correlated to soil gradation parameters using the ASTM soil gradation procedure.

Table 7.2 can be used to estimate long-term design infiltration rates directly from soil gradation data, subject to the approval of the local jurisdiction. As is true of Table 7.1, the long-term rates provided in Table 7.2 represent average conditions regarding site variability, the degree of long-term maintenance and pretreatment for Total Suspended Solids (TSS) control. The long-term infiltration rates in Table 7.2 may need to be decreased if the site is highly variable, or if maintenance and influent characteristics are not well controlled.

The infiltration rates provided in Tables 7.1 and 7.2 represent rates for homogeneous soil conditions. If more than one soil unit is encountered within 6 feet of the base of the facility, or 2.5 times the proposed maximum water design depth, use the lowest infiltration rate determined from each of the soil units as the representative site infiltration rate.

If soil mottling, fine silt or clay layers, which cannot be fully represented in the soil gradation tests, are present below the bottom of the infiltration pond, the infiltration rates provided in the tables will be too high and should be reduced. Based on limited full-scale infiltration data (Massmann and Butchart, 2000; Wiltsie, 1998), it appears that the presence of mottling indicates soil conditions that reduce the infiltration rate for homogeneous conditions by a factor of 3 to 4.

#### *Method 3 - In-situ Infiltration Measurements or Pilot Infiltration Tests (PIT)*

Where feasible, Ecology encourages in-situ infiltration measurements, using a procedure such as the Pilot Infiltration Test (PIT) described in Appendix V-B. Small-scale infiltration tests such as the EPA Falling Head

or double ring infiltrometer test (ASTM D3385-88) are not recommended unless modified versions are determined to be acceptable by Ecology or the City.

As with the previous methods, the infiltration rate obtained from the PIT shall be considered to be a short-term rate. To obtain long-term infiltration rates the short-term rates must be reduced by applying a total correction factor. The total correction factor is the sum of the partial correction factors, presented in Table 7.3, that account for site variability, number of tests conducted, degree of long-term maintenance, influent pretreatment/control, and potential for long-term clogging due to siltation and bio-buildup.

The typical range of partial correction factors to account for these issues based on TAC experience is summarized in Table 7.3. The range of partial correction factors is for general guidance only. The specific partial correction factors used shall be determined based on the professional judgment of the licensed engineer or other site professional considering all issues which may affect the long-term infiltration rate, subject to the approval of the City.

The following discussions are to provide guidance in determining the partial correction factors to apply in Table 7.3.

**Site variability and number of locations tested.** The number of locations tested must be capable of representing the subsurface conditions throughout the facility site. The partial correction factor used for this issue varies directly with the level of uncertainty for the occurrence of adverse subsurface conditions. If the range of uncertainty is low (for example, conditions are known to be uniform through previous exploration and site geological factors), one pilot infiltration test may be adequate to justify a partial correction factor at the low end of the range. If the level of uncertainty is high, due to highly variable site conditions or limited local testing data, a partial correction factor near the high end of the range may be appropriate. This might be the case where the site conditions are highly variable due to a deposit of ancient landslide debris, or buried stream channels. In these cases, even with many explorations and several pilot infiltration tests, the level of uncertainty may still be high.

**Degree of long-term maintenance to prevent siltation and bio-buildup.** The standard of comparison here is the long-term maintenance requirements provided in Section 4.6, and any additional requirements by the City. Full compliance with these requirements would be justification to use a partial correction factor at the low end of the range. If there is a high degree of uncertainty that long-term maintenance will be carried out consistently, or if the maintenance plan is poorly defined, a partial correction factor near the high end of the range may be justified.

**Degree of influent control to prevent siltation and bio-buildup.** A partial correction factor near the high end of the range may be justified under the following circumstances:

- If the infiltration facility is located in a shady area where moss or litter fall, buildup from the surrounding vegetation is likely and cannot be easily controlled through long-term maintenance.
- If there is minimal pre-treatment, and the influent is likely to contain moderately-high TSS levels.

If influent into the facility can be well controlled such that the planned long-term maintenance can easily manage siltation and biomass buildup, then a partial correction factor near the low end of the range may be justified.

The determination of long-term design infiltration rates from in-situ infiltration test data involves a considerable amount of engineering judgment. Therefore, when reviewing or determining the final long-term design infiltration rate, the City may consider the results of both textural analyses and in-situ infiltration tests results when available.

### **7.3.3 Site Suitability Criteria (SSC)**

This section specifies the site suitability criteria that must be considered for siting infiltration treatment systems. When a site investigation reveals that any of the nine applicable criteria cannot be met, appropriate mitigation measures must be implemented so that the infiltration facility will not pose a threat to safety, health, and the environment.

For infiltration treatment, site selection and design decisions, a geotechnical and hydrogeologic report should be prepared by a qualified engineer with geotechnical and hydrogeologic experience. A comparable professional, acceptable to the City, may also conduct the work if it is under the seal of a registered Professional Engineer. The design engineer may utilize a team of certified or registered professionals in soil science, hydrogeology, geology, and other related fields.

The nine site suitability criteria are as follows:

#### **SSC-1 Setback Criteria**

Setback requirements are generally required by the City, uniform building code requirements, or state regulations. Where a conflict between setbacks occurs, the City shall require compliance with the most stringent of the setback requirements from the various codes/regulations.

***Below are conditions the soils professional must evaluate to determine the need for additional or more stringent setbacks not found in this manual.***

#### ***The professional should evaluate:***

- Potential impacts to drinking water wells, septic tanks or drainfields, and springs used for public drinking water supplies. Infiltration facilities upgradient of drinking water supplies and within 1, 5, and 10-year time of travel zones must comply with Health Department

requirements (Washington Wellhead Protection Program, DOH, 12/93).

- Potential impacts from roadways subject to deicers or herbicides which are likely to be present in the influent to the infiltration system.
- Potential impacts to all building foundations in the vicinity of the proposed infiltration facility. Recommend investigating all building foundations within 100 feet downslope and 20 feet upslope from the facility.
- Potential impacts to all property lines within 20 feet of the facility.
- Potential impacts to a Native Growth Protection Easement (NGPE);  $\geq 20$  feet.
- Potential impacts to the top of slopes  $>15\%$  and within 50 feet.
- On-site and offsite structural stability due to extended subgrade saturation and/or head loading of the permeable layer, including the potential impacts to downgradient properties, especially on hills with known side-hill seeps.

### ***SSC-2 Ground Water Protection Areas***

A site is not suitable if the infiltrated storm water will cause a violation of Ecology's Ground Water Quality Standards (see SSC-9 for verification testing guidance). The City shall be consulted for applicable pretreatment requirements and whether the site is located in an aquifer sensitive area, sole source aquifer, or a wellhead protection zone. See Volume I, Chapter 2 for geographic specific requirements.

### ***SSC-3 High Vehicle Traffic Areas***

Treatment infiltration BMPs may be considered for runoff from areas of industrial activity and the high vehicle traffic areas described below, if appropriate pretreatment (including oil removal) is provided to ensure that groundwater quality standards will not be violated and that the infiltration facility will not be adversely affected.

High Vehicle Traffic Areas are:

- Commercial or industrial sites subject to an expected average daily traffic count (ADT)  $\geq 100$  vehicles/1,000 ft<sup>2</sup> gross building area (trip generation); and
- Road intersections with an ADT of  $\geq 25,000$  on the main roadway, or  $\geq 15,000$  on any intersecting roadway.

### ***SSC-4 Soil Infiltration Rate/Drawdown Time for Treatment***

*Infiltration Rates-Short-term and long-term:*

For treatment purposes the short-term soil infiltration rate should be 2.4 in./hour, or less, to a depth of 2.5 times the maximum design pond water



depth, or a minimum of 6 ft. below the base of the infiltration facility. This infiltration rate is also typical for soil textures that possess sufficient physical and chemical properties for adequate treatment, particularly for soluble pollutant removal (see SSC-6). It is comparable to the textures represented by Hydrologic Groups B and C. Long-term infiltration rates up to 2.0 inches/hour can also be considered, if the infiltration receptor is not a sole-source aquifer, and in the judgment of the site professional, the treatment soil has characteristics comparable to those specified in SSC-6 to adequately control the target pollutants.

The long-term infiltration rate should also be used for maximum drawdown time and routing calculations.

#### *Drawdown Time:*

It is necessary to empty the maximum ponded depth (water quality volume) from the infiltration basin within 24 hours from the completion of inflow to the storage pond in order to meet the following objectives:

- Restore hydraulic capacity to receive runoff from a new storm.
- Maintain infiltration rates.
- Aerate vegetation and soil to keep the vegetation healthy.
- Enhance the biodegradation of pollutants and organics in the soil.

#### **SSC-5 Depth to Bedrock, Water Table, or Impermeable Layer**

The base of all infiltration basins or trench systems shall be  $\geq 5$  feet above the seasonal high-water mark, bedrock (or hardpan) or other low permeability layer. A minimum separation of 3 feet may be considered if the groundwater mounding analysis, volumetric receptor capacity, and the design of the overflow and/or bypass structures are judged by the site professional to be adequate to prevent overtopping and to meet the site suitability criteria specified in this section.

#### **SSC-6 Soil Physical and Chemical Suitability for Treatment**

The soil texture and design infiltration rates should be considered along with the physical and chemical characteristics specified below to determine if the soil is adequate for removing the target pollutants. The following soil properties must be carefully considered in making such a determination:

- Cation exchange capacity (CEC) of the treatment soil must be  $\geq 5$  milliequivalents CEC/100 g dry soil (USEPA Method 9081). *Consider empirical testing of soil sorption capacity, if practicable.* Ensure that soil CEC is sufficient for expected pollutant loadings, particularly heavy metals. CEC values of  $>5$  meq/100g are expected in loamy sands, according to Rawls, et al. Lower CEC content may be considered if it is based on a soil loading capacity determination for the target pollutants that is accepted by the City.
- Depth of soil used for infiltration treatment must be a minimum of 18 inches.

- Organic Content of the treatment soil (ASTM D 2974): Organic matter can increase the sorptive capacity of the soil for some pollutants. The site professional should evaluate whether the organic matter content is sufficient for control of the target pollutant(s).
- Waste fill materials should not be used as infiltration soil media nor should such media be placed over uncontrolled or non-engineered fill soils.
- Engineered soils may be used to meet the design criteria in this chapter and the performance goals in Chapters 3 and 4. Field performance evaluation(s), using acceptable protocols, would be needed to determine feasibility, and acceptability by the local jurisdiction. See also Chapter 12.

#### ***SSC-7 Cold Climate and Impact of Roadway deicers***

- For cold climate design criteria (snowmelt/ice impacts) refer to D. Caraco and R. Claytor (1997).
- Potential impact of roadway deicers on potable water wells must be considered in the siting determination. Mitigation measures must be implemented if infiltration of roadway deicers can cause a violation of groundwater quality standards.

#### ***SSC-8 Verification Testing of the Completed Facility***

Verification testing of the completed full-scale infiltration facility is recommended to confirm that the design infiltration parameters are adequate to manage the design volume and meet the pollutant capture objectives of the infiltrating soil. The site professional should determine the duration and frequency of the verification testing program for the potentially impacted groundwater. The groundwater monitoring wells installed during site characterization may be used for this purpose. Long-term in-situ drawdown and water quality monitoring for a two-year period would be preferable (see Volume III, Chapter 3, Section 3.2.6 – SSC-7).

#### **7.3.4 General Information for Infiltration Basins, Trenches, and Bio-infiltration Swales**

This section covers general design, construction, and maintenance criteria that apply to infiltration basins, trenches, and bio-infiltration swales.

##### ***Sizing Criteria***

Size should be determined by one of the following methods:

- 1) Routing 91% of the runoff volume, as predicted by Western Washington Hydrology Model (WWHM) (or an approved, equivalent continuous runoff model) through the facility; or
- 2) Using the Simple Method, discussed below, that infiltrates the Water Quality Design Storm Volume within 24 hours.

### **Off-line versus On-line Treatment**

Infiltration facilities for treatment can be located upstream or downstream of detention and can be off-line or on-line. For off-line facilities, the flow splitter should be designed to route the water quality design flow rate to the infiltration facility. Until a continuous runoff model is available that identifies the flow rate associated with 91% of the runoff volume, use:

- Estimate for that flow rate as identified in Chapter 4 for upstream facilities;
- 2-year return frequency flow rate for flows downstream of detention.

The storage pond above the infiltration surface should not overflow since all flows routed to it are at or below the water quality design flow rate.

*Note: An emergency overflow should still be included in the design. See Chapter 4 for flow splitter design details.*

For on-line infiltration facilities, the storage pond should be sized to restrict the total amount of overflow to 9% of the total runoff volume of the long-term time series or less depending on the design objective.

*Note: Refer to Volume III for overflow structure design details.*

### **Method of Design and Sizing Criteria Procedure**

- **Simple Method**

$$A_{inf} = A_t Q_d / F_t$$

$A_{inf}$  = Bottom surface area of infiltration facility

$A_t$  = tributary drainage area

$Q_d$  = the runoff depth for the 6-month, 24-hour storm, estimated using the SCS (NRCS) Curve Number Equations approach detailed in Volume III, Chapter 2.

$F$  = long-term infiltration rate

$t$  = 24 hours maximum drawdown time

- **Continuous Runoff Method**

Refer to Chapter 8 for sizing sand filters using the Continuous Runoff Model Sizing Method. The only difference for sizing an infiltration facility is that the infiltration rate is a function only of surface area and ponded hydraulic head does not play a role. The long-term infiltration rate, as determined in Section 7.3.2 is multiplied by the horizontal surface area of an infiltration bed to obtain a volumetric infiltration rate that is input to the WWHM as a stage-storage-discharge table.

*Note: Horizontal surface area changes with stage if the sidewalls are sloped.*

- **Control of Side-Wall Seepage**

Typically, side-wall seepage is not a concern if seepage occurs through the same stratum as the bottom of the facility. However, for engineered soils or for soils with very low permeability, the potential to bypass the treatment soil through the side-walls may be significant. In

those cases, the side-walls must be lined, either with an impervious liner or with at least 18 inches of treatment soil, to prevent seepage of untreated flows through the side walls.

- **Construction Criteria**

- Excavation - Initial excavation should be conducted to within 1-foot of the final elevation of the floor of the infiltration facility. Final excavation to the finished grade should be deferred until all disturbed areas in the upgradient watershed have been stabilized or protected. The final phase of excavation should remove all accumulated sediment. After construction is completed, prevent sediment from entering the infiltration facility by first conveying the runoff water through an appropriate pretreatment system such as a pre-settling basin, wet pond, or sand filter.
- Infiltration facilities should generally not be used as temporary sediment traps during construction. If an infiltration facility is to be used as a sediment trap, it must not be excavated to final grade until after the upgradient drainage area has been stabilized. Any accumulation of silt in the basin must be removed before putting it in service.
- Traffic Control - Relatively light-tracked equipment is recommended for excavation to avoid compaction of the floor of the infiltration facility. The use of draglines and trackhoes should be considered. The infiltration area should be flagged or marked to keep equipment away.

- **Maintenance Criteria**

Provision should be made for regular and perpetual maintenance of the infiltration basin/trench, including replacement and/or reconstruction of the treatment infiltration medium. Maintenance should be conducted when water remains in the basin or trench for more than 24 hours or overflows the basin/pond. Adequate access for O&M must be included in the design of infiltration basins and trenches. An Operation and Maintenance Plan, approved by the City, should ensure maintaining the desired efficiency of the infiltration facility.

Debris/sediment accumulation - Removal of accumulated debris/sediment in the basin/trench should be conducted every 6 months or as needed to prevent clogging, or when water remains in the pond for greater than 24hours.

The treatment soil should be replaced or amended as needed to ensure maintaining adequate treatment capacity.

- **Verification of Performance**

During the first 1-2 years of operation, verification testing as specified in SSC-9 is strongly recommended, along with a maintenance program that achieves expected performance levels. Operating and maintaining groundwater monitoring wells is also strongly encouraged.

## **7.4 Best Management Practices (BMPs) for Infiltration and Bio-infiltration Treatment**

The three BMPs discussed below are recognized currently as effective treatment techniques using infiltration and bio-infiltration. Selection of a specific BMP should be coordinated with the Treatment Facility Menus provided in Chapter 3.

## **BMP T7.10 Infiltration Basins**

### ***Description:***

Infiltration basins are typically earthen impoundments with a grass cover, as shown schematically in Figure 7.2. - Example Infiltration Basin/Pond.

### ***Additional Design Criteria specific for Basins***

- The slope of the basin bottom should not exceed 3% in any direction.
- Treatment infiltration basins must have sufficient vegetation established on the basin floor and side slopes to prevent erosion and sloughing of the sideslopes and to provide additional pollutant removal. Erosion protection of inflow points to the basin must also be provided (e.g., riprap, flow spreaders, energy dissipaters). Select suitable vegetative materials for the basin floor and side slopes to be stabilized. Refer to Chapter 9 for recommended vegetation.
- A minimum of 1-foot of freeboard is recommended when establishing the design water depth at the long-term infiltration rate. Freeboard is measured from the rim of the infiltration facility to the maximum ponding level or from the rim down to the overflow point.
- A non-erodible outlet or spillway must be established at a proper elevation to discharge overflow. Ponding level, drawdown time, and storage volume are calculated from that reference point.

### ***Maintenance Criteria Specific for Basins***

- Maintain basin floor and side slopes to promote dense turf with extensive root growth. This enhances infiltration, prevents erosion and consequent sedimentation of the basin floor, and prevents invasive weed growth. Bare spots are to be immediately stabilized and revegetated.
- Vegetation growth should not be allowed to exceed 18 inches in height. Mow the slopes periodically and check for clogging and erosion.
- Seed mixtures should be the same as those recommended in Chapter 9. The use of low-growing, stoloniferous grasses will permit long intervals between mowing. Mowing twice a year is generally satisfactory. Fertilizers should be applied only as necessary and in limited amounts to avoid contributing to the pollution problems, including groundwater pollution. Consult the local extension agency for appropriate fertilizer types, including slow release fertilizers, and application rates.

## **BMP T7.20 Infiltration Trenches**

### ***Description:***

Infiltration trenches are generally at least 24 inches wide, and are backfilled with a coarse stone aggregate, allowing for temporary storage of storm water runoff in the voids of the aggregate material. Stored runoff then gradually infiltrates into the surrounding soil. The surface of the trench can be covered with grating and/or consist of stone, gabion, sand, or a grassed covered area with a surface inlet. Perforated rigid pipe of at least 8-inch diameter can also be used to distribute the storm water in a stone trench. Trench configurations by Schueler (Figures 7.3 – 7.8) with inlet filter strips and/ or 6-12 inches bottom sand layers are shown.

Due to accessibility and maintenance limitations infiltration trenches must be carefully designed, constructed and maintained.

### **Additional Design Criteria specific for Trenches**

- Slope - The slope of the trench bottom should not exceed 3% in any direction.
- Access Port - Consider including an access port or open or grated top for accessibility to conduct inspections and maintenance.
- Backfill Material - The aggregate material for the infiltration trench should consist of a clean aggregate with a maximum diameter of 3 inches and a minimum diameter of 1.5 inches. Void space for these aggregates should be in the range of 30 percent to 40 percent.
- Filter Fabric - Protective permeable geotextile filter fabric should line the top and sides of the trench from one foot below the aggregate surface. The bottom sand or removable permeable fabric layer is optional.
- Overflow Channel - A non-erosive overflow channel or path, leading to a stabilized watercourse, should be provided at the 24-hour drawdown level.
- Observation Well - An observation well should be installed at the lower end of the infiltration trench to check for water levels, drawdown time, and to show the impact of sediments. Figure 7.9 illustrates observation well details. A typical observation well consists of a perforated PVC pipe, 4 to 6 inches in diameter, constructed flush with the ground elevation. For larger trenches a 12-36 inch diameter well can be installed to facilitate maintenance operations, such as pumping out the sediment. The top of the well should be capped, or covered with an ordinary drainage grate.
- Surface Cover - A stone-filled trench can be placed under a porous or impervious cover to conserve space.

### **Construction Criteria Specific for Trenches**

- Trench Preparation - Excavated materials must be placed away from the trench sides to enhance trench wall stability. Care should also be

taken to keep this material away from slopes, neighboring property, sidewalks and streets. It is recommended that this material be covered with plastic (see Erosion/Sediment Control Measures in Volume II).

- **Stone Aggregate Placement and Compaction** - The stone aggregate should be placed in lifts and compacted using plate compactors. As a rule of thumb, a maximum loose lift thickness of 12 inches is recommended. The compaction process ensures geotextile conformity to the excavation sides, thereby reducing potential piping and geotextile clogging, and settlement problems.
- **Potential Contamination** - Prevent natural or fill soils from intermixing with the stone aggregate. All contaminated stone aggregate must be removed and replaced with uncontaminated stone aggregate.
- **Overlapping and Covering** - Following the stone aggregate placement, the geotextile must be folded over the stone aggregate to form a 12-inch minimum longitudinal overlap. When overlaps are required between rolls, the upstream roll should overlap a minimum of 2 feet over the downstream roll in order to provide a shingled effect.
- **Voids Behind Geotextile** - Voids between the geotextile and excavation sides must be avoided. Removing boulders or other obstacles from the trench walls eliminates one source of such voids. Natural soils should be placed in these voids at the most convenient time during construction to ensure geotextile conformity to the excavation sides. Soil piping and geotextile clogging, and possible surface subsidence will be avoided by this remedial process.
- **Unstable Excavation Sites** - Vertically excavated walls may be difficult to maintain in areas where the soil moisture is high or where soft or cohesionless soils predominate. Trapezoidal, rather than rectangular, cross-sections may be needed.

#### ***Maintenance Criteria Specific for Trenches***

- Sediment buildup in the top foot of stone aggregate or the surface inlet should be monitored on the same schedule as the observation well.



## **BMP T7.30 Bio-infiltration Swale**

### ***Description***

Bio-infiltration swales, also known as Grass Percolation Areas, combine grassy vegetation and soils to remove storm water pollutants by percolation into the ground. Their pollutant removal mechanisms include filtration, soil sorption, and uptake by vegetative root zones.

In general, bio-infiltration swales are used for treating storm water runoff from roofs, roads and parking lots. Flows greater than design flows are typically overflowed to the subsurface through an appropriate conveyance facility, or an overflow channel to storm water.

### ***Additional Design Criteria Specific for Bio-infiltration Swales***

- Use the same sizing guidance, off-line and on-line guidance, and design procedures as in Section 7.3.4.
- Drawdown time for the maximum ponded volume: 24 hours max.
- Swale bottom: flat with a longitudinal slope less than 1%.
- The maximum ponded level: 6 inches.
- Treatment soil to be at least 18 inches thick with a CEC of at least 5 meq/100 gm dry soil, organic content of at least 1%, and sufficient target pollutant loading capacity. The design soil thickness may be reduced to as low as 6 inches if appropriate performance data demonstrates that the vegetated root zone and the natural soil can be expected to provide adequate removal and loading capacities for the target pollutants. The design professional should calculate the pollutant loading capacity of the treatment soil to estimate if there is sufficient treatment soil volume for an acceptable design period (see Criteria for Assessing the Trace Element Removal Capacity of Bio-filtration Systems, Stan Miller, Spokane County, June 2000).
- Other combinations of treatment soil thickness, CEC, and organic content design factors can be considered if it is demonstrated that the soil and vegetation will provide a target pollutant loading capacity and performance level acceptable to the local jurisdiction.
- The treatment zone depth of 6 inches or more should contain sufficient organics and texture to ensure good growth of the vegetation.
- The treatment soil infiltration rate should not exceed 1-inch per hour for a treatment zone depth of 6 inches relying on the root zone to enhance pollutant removal. The Site Suitability Criteria in Section 7.3.3 must also be applied; if a design soil depth of 18 inches is used then a maximum infiltration rate of 2.4 inches per hour is applicable.
- Native or adapted grass should be used.
- Pretreatment of debris, gross TSS, and oil & grease to prevent the clogging of the treatment soil and/or growth of the vegetation, where necessary.

- Identify pollutants, particularly in industrial and commercial area runoff, that could cause a violation of Ecology's groundwater quality standards (Chapter 173-200 WAC). Include appropriate mitigation measures (pretreatment, source control, etc.) for those pollutants.

<b>Table 7.1 Recommended Infiltration Rates Based on USDA Soil Textural Classification</b>			
	<b>*Short-Term Infiltration Rate (in./hr)</b>	<b>Correction Factor, CF</b>	<b>Estimated Long- Term (Design) Infiltration Rate (in./hr)</b>
Clean sandy gravels and gravelly sands (i.e., 90% of the total soil sample is retained in the #10 sieve)	20	2	10 **
Sand	8	4	2***
Loamy Sand	2	4	0.5
Sandy Loam	1	4	0.25
Loam	0.5	4	0.13

\* From WEF/ASCE, 1998.

\*\* Not recommended for treatment

\*\*\* Refer to SSC-4 and SSC-6 for treatment acceptability criteria

<b>Table 7.2 Alternative Infiltration Rates Based on ASTM Gradation Testing</b>	
<b>D<sub>10</sub> Size from ASTM D422 Soil Gradation Test (mm)</b>	<b>Estimated Long-Term (Design) Infiltration Rate (in./hr)</b>
≥ 0.4	9*
0.3	6.5*
0.2	3.5*
0.1	2.0**
0.05	0.8

\* Not recommended for treatment

\*\* Refer to SSC-4 and SSC-6 for treatment acceptability criteria

<b>Table 7.3 Correction Factors to be Used With In-Situ Infiltration Measurements to Estimate Long-Term Design Infiltration Rates</b>	
<b>Issue</b>	<b>Partial Correction Factor</b>
Site variability and number of locations tested	CF <sub>v</sub> = 1.5 to 6
Degree of long-term maintenance to prevent siltation and bio-buildup	CF <sub>m</sub> = 2 to 6
Degree of influent control to prevent siltation and bio-buildup	CF <sub>i</sub> = 2 to 6

Total Correction Factor (CF) = CF<sub>v</sub> + CF<sub>m</sub> + CF<sub>i</sub>

# Textural Triangle U.S.D.A.

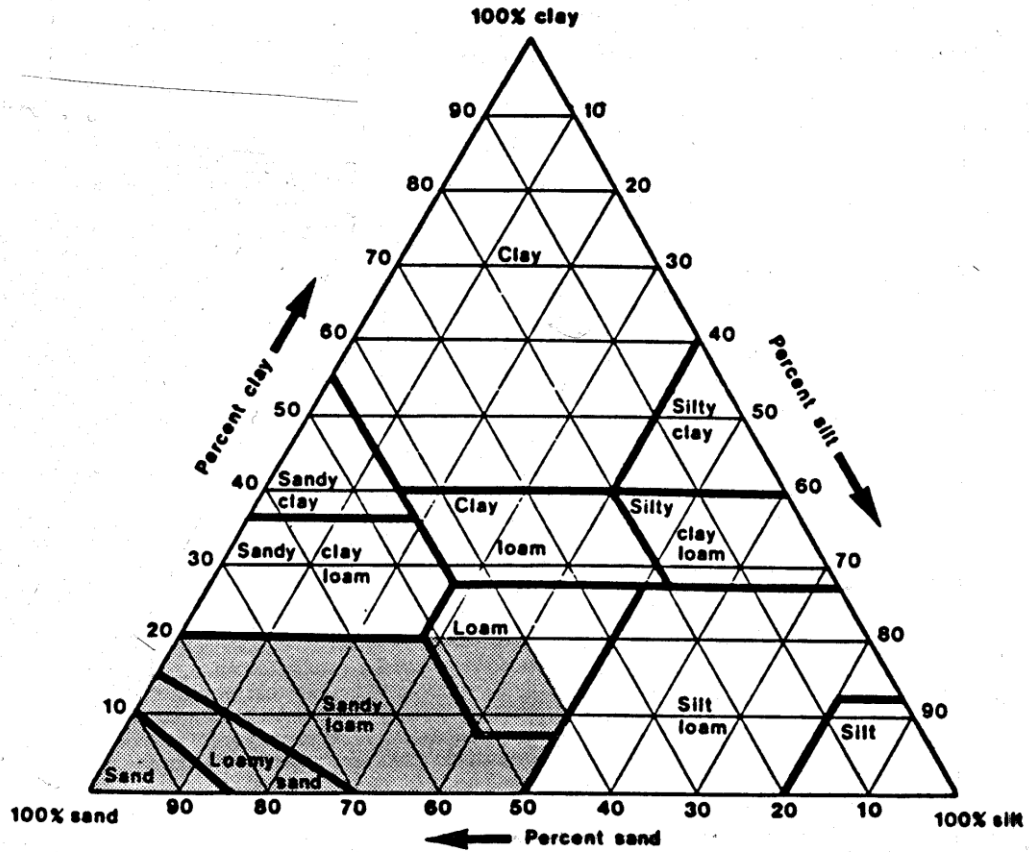
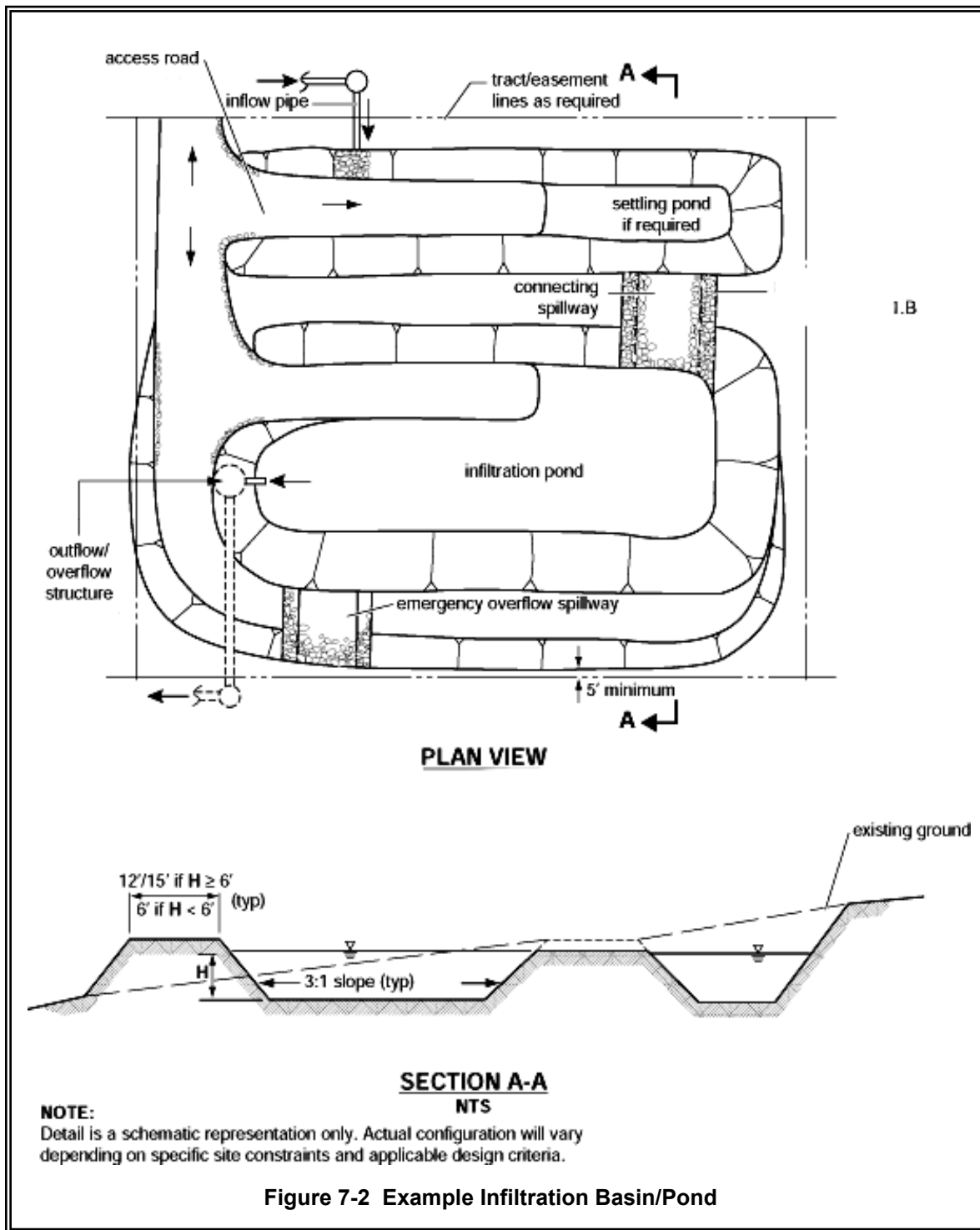


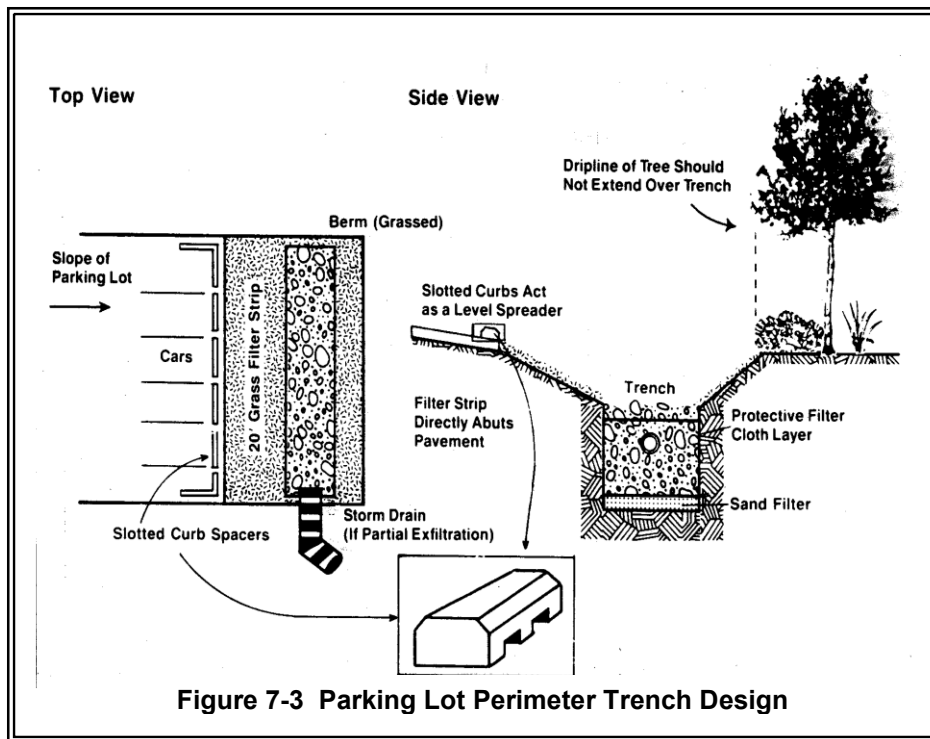
Figure 7-1 USDA Textural Triangle

Note: Shaded area applicable for design of infiltration BMPs

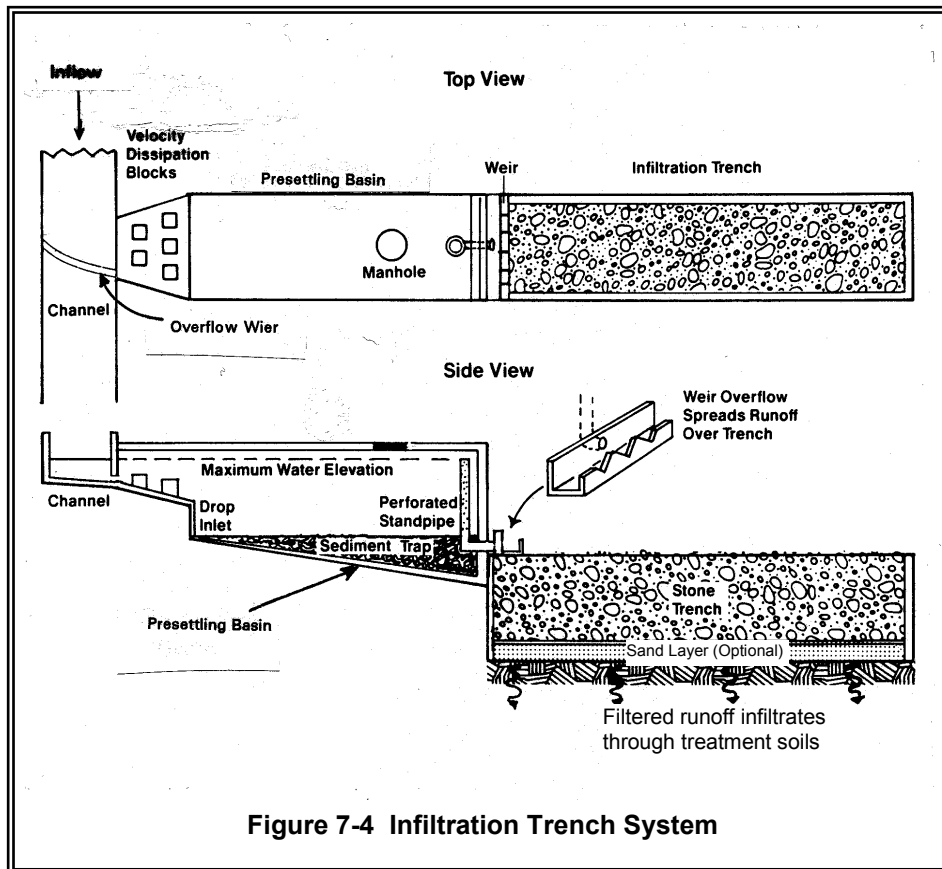
Source: USDA (reproduced with permission)



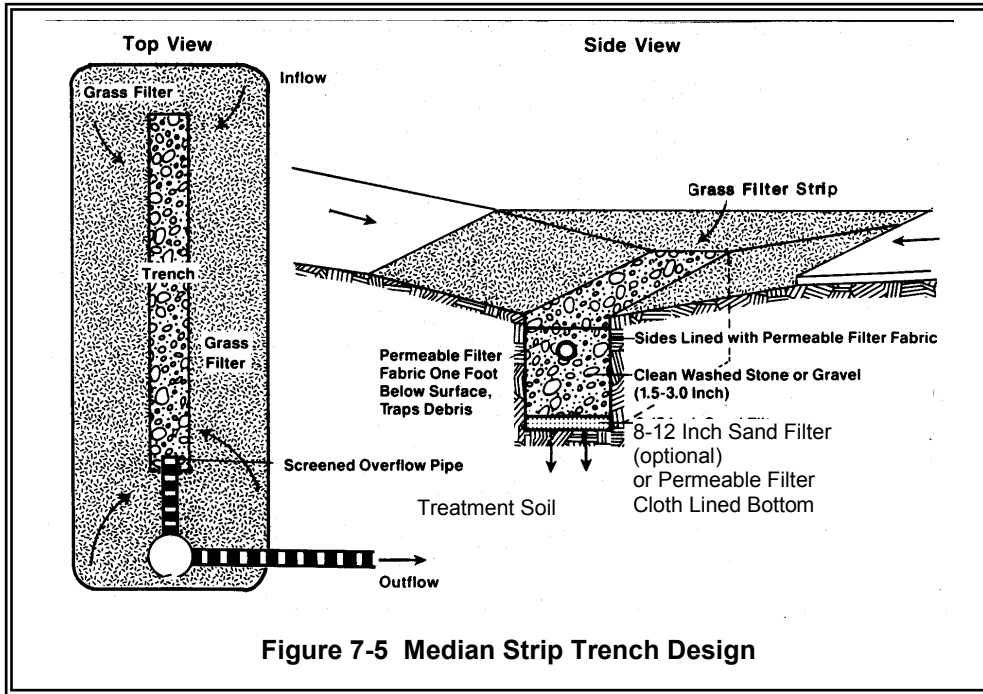
Source: King County (reproduced with permission)



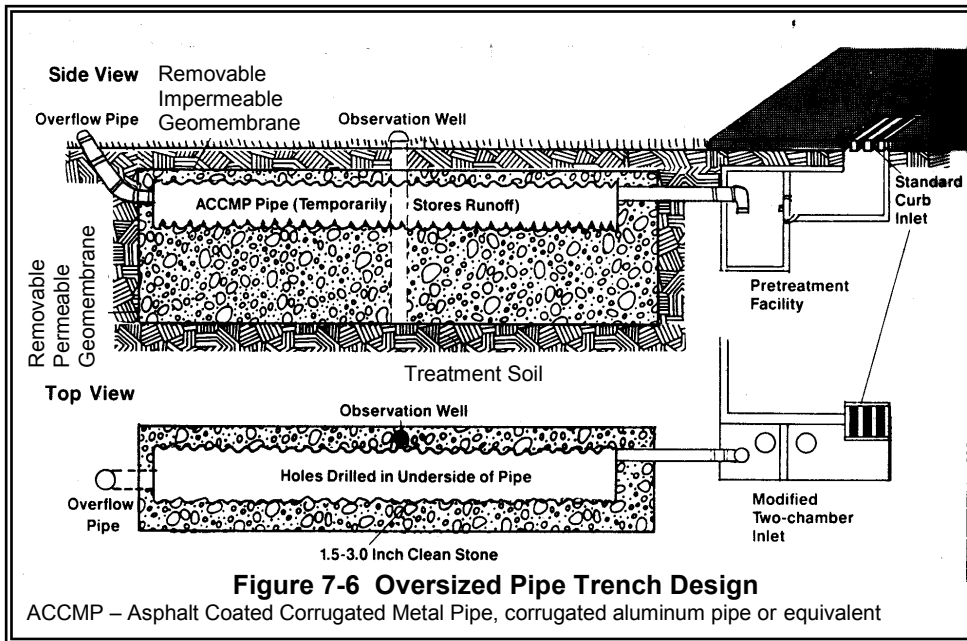
Source: Schueler (reproduced with permission)



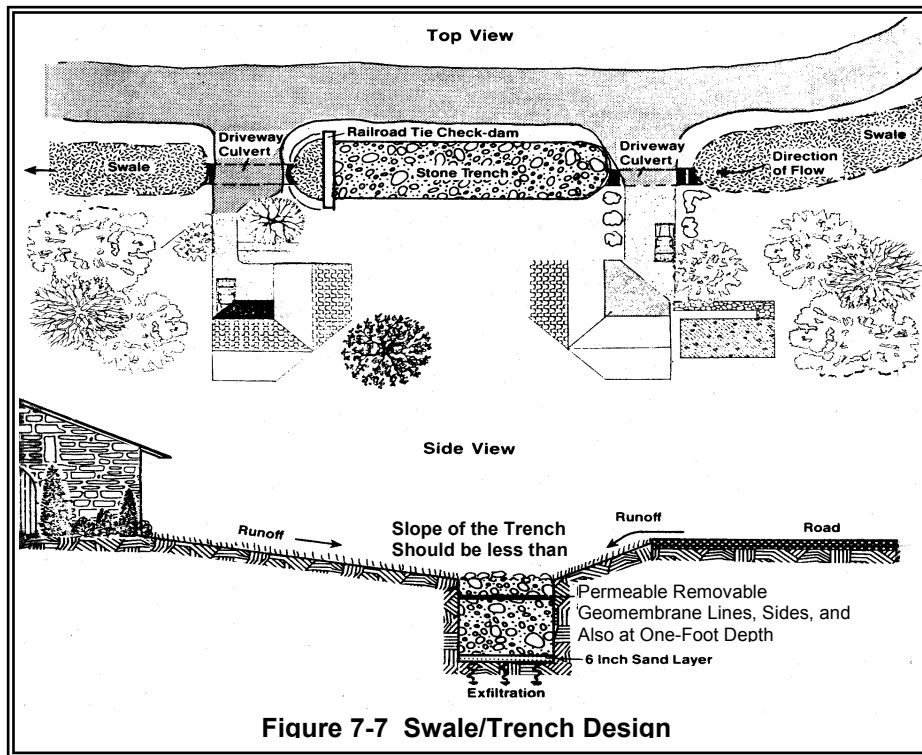
Source: Schueler (reproduced with permission)



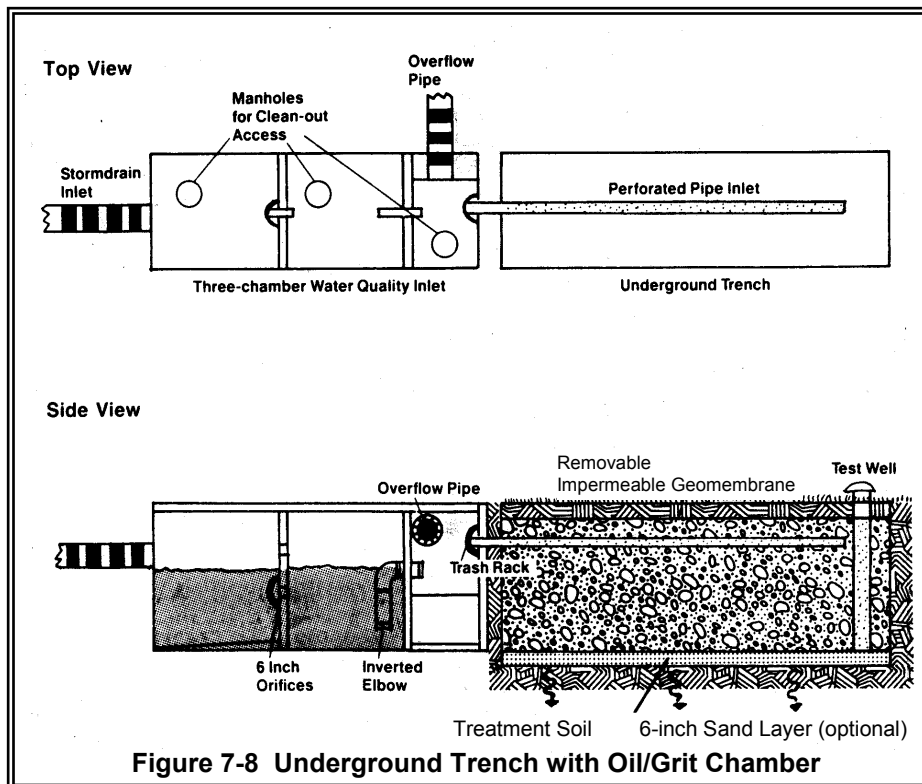
Source: Schueler (reproduced with permission)



Source: Schueler (reproduced with permission)

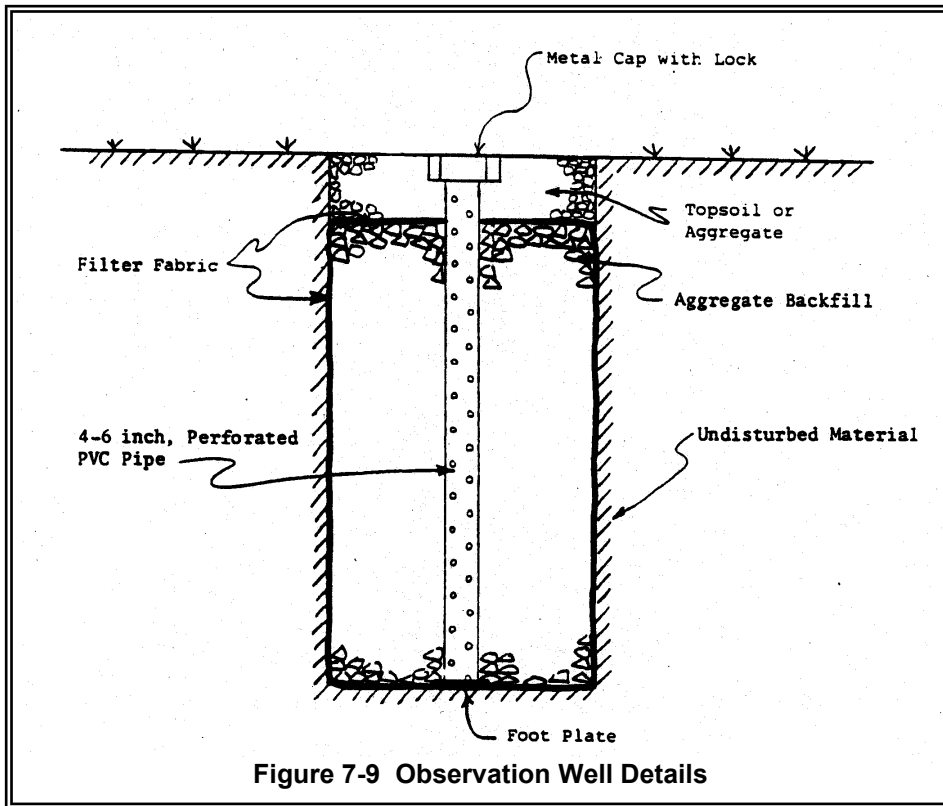


Source: Schueler (reproduced with permission)



Source: Schueler (reproduced with permission)





**Figure 7-9 Observation Well Details**

Source: King County (reproduced with permission)

# Chapter 8 - Sand Filtration Treatment Facilities

---

*Note: Figures in Chapter 8 are courtesy of King County, except as noted.*

This Chapter presents criteria for the design, construction and maintenance of runoff treatment sand filters including basin, vault, and linear filters. Two Best Management Practices (BMPs) are discussed in this Chapter:

BMP T8.10 Sand Filter Vault  
BMP T8.20 Linear Sand Filter

## 8.1 Purpose

To collect and treat the design runoff volume to remove TSS, phosphorous, and insoluble organics (including oils) from stormwater.

## 8.2 Description

A typical sand filtration system consists of a pretreatment system, flow spreader(s), a sand bed, and the underdrain piping. The sand filter bed includes a geotextile fabric between the sand bed and the bottom underdrain system.

An impermeable liner under the facility may also be needed if the filtered runoff requires additional treatment to remove soluble groundwater pollutants, or in cases where additional groundwater protection was mandated. The variations of a sand filter include a basic or large sand filter, sand filter with level spreader, sand filter vault, and linear sand filter. (Figures 8.1 through 8.7 provide examples of various sand filter configurations.)

## 8.3 Performance Objectives

**Basic Sand Filter** - Basic sand filters are expected to achieve the performance goals for Basic Treatment. Based upon experience in King County and Austin, Texas, basic sand filters should be capable of achieving the following average pollutant removals:

- 80 percent TSS at influent Event Mean Concentrations (EMCs) of 30-300 mg/L (King County, 1998) (Chang, 2000).
- Oil and grease to below 10 mg/L daily average and 15 mg/L at any time, with no ongoing or recurring visible sheen in the discharge.

**Large Sand Filter** - **Large sand filters are expected to remove at least 50 percent of the total phosphorous compounds (as TP) by collecting and treating 95% of the runoff volume. (ASCE and WEF, 1998)**

## 8.4 Applications and Limitations

Sand filtration can be used in most residential, commercial, and industrial developments where debris, heavy sediment loads, and oils and greases will not clog or prematurely overload the sand, or where adequate pretreatment is provided for these pollutants. Specific applications

include residential subdivisions, parking lots for commercial and industrial establishments, gas stations, high-use sites, high-density multi-family housing, roadways, and bridge decks.

Sand filters should be located off-line before or after detention (Chang, 2000). Sand filters are also suited for locations with space constraints in retrofit, and new/re-development situations. Overflow or bypass structures must be carefully designed to handle the larger storms. An off-line system is sized to treat 91% runoff volume predicted by a continuous runoff model. If a project must comply with Minimum Requirement #7, Flow Control, the flows bypassing the filter and the filter discharge must be routed to a retention/detention facility.

Pretreatment is necessary to reduce velocities to the sand filter and remove debris, floatables, large particulate matter, and oils. In high water table areas adequate drainage of the sand filter may require additional engineering analysis and design considerations. An underground filter should be considered in areas subject to freezing conditions. (Urbonas, 1997)

## 8.5 Site Suitability

The following site characteristics should be considered in siting a sand filtration system:

- Space availability, including a presettling basin.
- Sufficient hydraulic head, at least 4 feet from inlet to outlet.
- Adequate Operation and Maintenance capability including accessibility for O & M.
- Sufficient pretreatment of oil, debris and solids in the tributary runoff.

## 8.6 Design Criteria

**Objective:** To capture and treat the Water Quality Design Storm volume (when using the Simple Sizing Method described below), or 91% of the runoff volume (95% for large sand filter) predicted by a continuous runoff model, and bypass/overflow 9% of the total runoff volume to the R/D system. Off-line sand filters can be located either upstream or downstream of detention facilities. On-line sand filters should only be located downstream of detention.

**Simple Sizing Method:** This method applies to the off-line placement of a sand filter upstream or downstream of detention facilities. A conservative design approach is provided below using a routing adjustment factor that does not require flow routing computations through the filter. An alternative simple approach for off-line placement downstream of detention facilities is to route the full 2-year release rate from the detention facility (sized for duration control) to a sand filter with sufficient surface area to infiltrate at that flow rate.

**Basic Sand Filter:** For sizing a Basic Sand Filter, a 0.7 routing adjustment factor is applied to compensate for routing through the sand bed at the maximum pond depth. A flow splitter should be designed to

route the water quality design flow rate to the sand filter. Until a continuous runoff model is available that identifies the flow rate associated with 91% of the runoff volume, use the estimate for that flow rate as identified in Chapter 4. The estimate is a percentage of the predicted 2-year return frequency flow as predicted by the Western Washington Hydrology Model. Use the adjustment for the 15-minute time series.

**Large Sand Filter:** For sizing a Large Sand Filter (LSF), use the same procedure as outlined above for the Basic Sand Filter. Then apply a scale-up factor of 1.6 to the surface area. This is considered a reasonable average for various impervious tributary sources. For a Large Sand Filter the flow splitter upstream or downstream of the detention facility should be designed to route the flow rate associated with conveying 95% of the runoff volume to the sand filter. Until a continuous runoff model is available that identifies the flow rate associated with conveying 95% of the runoff volume for sizing the Large Sand filter, use the water quality design flow rate for the Basic Sand Filter multiplied by 1.2.

*Note: An overflow should be included in the design of the basic and large sand filter pond. The overflow height should be at the maximum hydraulic head of the pond above the sand bed.*

**Example Calculation using the simple sizing method and a routing adjustment factor:**

**Design Specifications:**

*Background: The sizing of the sand filter is based on routing the design runoff volume through the sand filter and using Darcy's Law to account for the increased flow through the sand bed caused by the hydraulic head variations in the pond above the sand bed. Darcy's Law is represented by the following equation:*

$Q_{sf} = KiA_{sf} = FA_{sf}$	where: $i = (h+L)/L$
Therefore,	$A_{sf} = Q_{sf}/Ki$
Also,	$Q_{sf} = A_t Q_d R/t$
Substituting for $Q_{sf}$ ,	$A_{sf} = A_t Q_d R/Kit$
Or,	$A_{sf} = A_t Q_d R/\{K(h+L)/L\}t$
Or,	$A_{sf} = A_t Q_d R/Ft$

Where:

$Q_{sf}$  is the flow rate in cu. feet per day (or ft<sup>3</sup>/sec.) at which runoff is filtered by the sand filter bed,

$A_{sf}$  is the sand filter surface area (sq. ft.)

$Q_d$  is the design storm runoff depth (ft.) for the 6 month, 24-hour storm. It is estimated using the SCS Curve Number equations detailed in Volume III, Chapter 2.

R is a routing adjustment factor. Use R = 0.7.

$A_t$  is the tributary drainage area (sq. ft.)

$K$  is the hydraulic conductivity of the sand bed. Use 2 ft./day or 1.0 inch/hour at full pre-sedimentation

$i$  is the hydraulic gradient of the pond above the filter;  $(h+L)/L$ , (ft/ft)

$F=Ki$  is the filtration rate, ft./day (or inches per hour)

$d$  is the maximum sand filter pond depth, and  $h = d/2$  in ft.

$t$  is the recommended maximum drawdown time of 24 hours from the completion of inflow into the sand filter pond (assume ponded pre-settling basin) of a discrete storm event to the completion of outflow from the sand filter underdrain of that same storm event.

$L$  is the sand bed depth; Use 1.5 ft.

*Given condition:*

- Sedimentation basin fully ponded and no pond water above sand filter (Full sedimentation prior to sand filter-24 hours residence of WQ storm runoff)
- $A_t = 10$  acres is tributary drainage area
- $Q_d = 0.922$  inches (0.0768 ft.), for SeaTac Rainfall
- with Curve Number = 96.2 for 85% impervious and 15% till grass tributary surfaces
- $R = 0.7$ , the routing adjustment factor
- Maximum drawdown time through sand filter, 24 hours
- Maximum pond depth above sand filter, example at 3 and 6 feet,
- $h = 1.5$  and 3 feet
- Design Hydraulic Conductivity of basic sand filter,  $K$ , 2.0 feet/day (1 inch/hour)

*Using Design Equation:*

$$A_{sf} = A_t Q_d R L / K t (h+L)$$

At pond depth of 6 feet:

$$A_{sf} = (10)43560(0.0768)(.7)(1.5)/(2)(1)(4.5) = 3911 \text{ square feet}$$

Therefore  $A_{sf}$  for Basic Sand Filter becomes:

**3911 sq. feet at pond depth of 6 feet**

**5867 sq. feet at pond depth of 3 feet**

Using the 1.6 scale-up factor, the Large Sand Filter design sizes for the conditions of this example become:

**6258 sq. feet at pond depth of 6 feet**

**9387 sq. feet at pond depth of 3 feet**

#### **Continuous Runoff Model Sizing Method:**

*Basic Sand Filter.* This method is intended to capture and treat 91% of the runoff volume through use of a continuous runoff model coupled with a flow-routing routine that determines stage-storage-discharge relationships. At the time of publication of this manual, a 15-minute time series and a flow routing routine for sizing sand filters is not available with the Western Washington Hydrology Model (WWHM). Until a 15-minute time series is available, the 1-hour time series in the WWHM can be used for facility sizing. A spreadsheet must be used to calculate filtration rates as a function of head and surface area. A stage-storage-discharge table can be imported to the WWHM as an electronic text file, or, the table can be typed directly into the WWHM. The WWHM will route the post-development stormwater runoff through the stage-storage-discharge table. A spreadsheet analysis of the flow duration table produced by the WWHM can determine the total quantities discharged and bypassed for verifying that 91% of the runoff volume has been treated.

*Off-line:* An off-line, basic sand filter located upstream of detention facilities should have an upstream flow splitter that is designed to bypass the incremental portion of flows above the water quality design flow rate (using 15-minute time steps). The long-term runoff time series used as input to the sand filter should be modified to use the water quality design flow rate for all flows above that rate. The design overflow volume for off-line sand filters is zero since all flows routed to the filter will be at or below the water quality design flow. Therefore, the goal is to size the storage reservoir such that its capacity is not exceeded (Note: an emergency overflow should still be included in the design).

Unfortunately, at the time of publication of this manual, the user does not have access to the runoff time series to modify it as described above for design of off-line facilities. Until that capability is provided to the user, the storage reservoir for the off-line facility can be sized as if in an on-line mode. All of the post-development time series is routed to the storage reservoir, which is then sized to overflow 9% of the total runoff volume of the time series. In actual practice, an offline flow splitter will not route all of the post-development time series to the storage reservoir, and so the reservoir should not overflow if operating within design criteria. This design approach should result in slightly oversizing the storage reservoir.

Downstream of detention facilities, the flow splitter should be designed to bypass the incremental portion of flows above the flow rate that corresponds with treating 91% of the runoff volume of the long-term time series. Because the flows are dampened by the detention facility, this flow rate will be lower than the water quality design flow rate for facilities located upstream of detention. Accordingly, the post-detention runoff

time series, used as input to the filter, should be adjusted to use the flow rate corresponding to treating 91% of the runoff volume for all flows above that rate. Note: Downstream of detention facilities, a one-hour time series may be used to compute the sand filter size until such time as a 15-minute time series is available. Due to the flow dampening effect of the detention facilities, there should not be much difference between a sand filter sized to treat 91% of the runoff volume using 15-minute versus 1-hour time series data.

*On-line:* Sand filter designs that are on-line (i.e., all flows enter the storage reservoir) should only be allowed downstream of detention facilities to prevent exposure of the sand filter surface to high flow rates that could cause loss of media and previously removed pollutants. The storage pond above the sand bed should be sized to restrict the total amount of overflow from the reservoir to 9% of the total runoff volume of the long-term time series.

*Large Sand Filter:* This method is intended to capture and treat 95% of the runoff volume through use of a continuous runoff model coupled with a flow-routing routine that determines stage-storage-discharge relationships.

*Off-line:* An off-line, large sand filter should have an upstream flow splitter that is designed to bypass the incremental portion of flows above the flow rate that corresponds with treating 95% of the runoff volume of the long-term time series (using 15-minute time steps). The design overflow volume for off-line sand filters is zero since all flows routed to the filter must be treated. Therefore, the goal is to size the storage reservoir such that its capacity is not exceeded (Note: An emergency overflow should still be included in the design). Because of the flow dampening effects of a detention facility, a large sand filter downstream of detention facilities will be smaller than a filter upstream of detention. A conservative design would use a flow splitter to route the full 2-year release rate from the detention facility, sized for flow duration control, to a filter with sufficient surface area to infiltrate at that flow rate. Such a design should treat over 95% of the runoff volume.

*On-line:* Sand filter designs that are on-line (i.e., all flows enter the storage reservoir) should only be allowed downstream of detention facilities to prevent exposure of the sand filter surface to high flow rates that could cause loss of media and previously removed pollutants. The storage pond should be sized to restrict the total amount of overflow from the reservoir to 5% of the total runoff volume of the long-term time series. This is not a preferred design because of the extended timeframe during which the filter is saturated. This will reduce its potential for phosphorus removal.

***Additional Design Information:***

1. Runoff to be treated by the sand filter must be pretreated (e.g., presettling basin, etc. depending on pollutants) to remove debris and other solids, and oil from high use sites.
2. Inlet bypass and flow spreading structures (e.g., flow spreaders, weirs or multiple orifice openings) should be designed to capture the applicable design flow rate, minimize turbulence and to spread the flow uniformly across the surface of the sand filter. Stone riprap or other energy dissipation devices should be installed to prevent gouging of the sand medium and to promote uniform flow. Include emergency spillway or overflow structures (see Volume III).
3. The following are design criteria for the underdrain piping: *(types of underdrains include a central collector pipe with lateral feeder pipes; or a geotextile drain strip in an 8-inch gravel backfill or drain rock bed; or longitudinal pipes in an 8-inch gravel backfill or drain rock with a collector pipe at the outlet end.)*
  - Upstream of detention, underdrain piping should be sized to handle double the two-year return frequency flow indicated by the WWHM (the doubling factor is a conversion from the 1-hr. time step to a 15 minute time step). Downstream of detention the underdrain piping should be sized for the two-year return frequency flow indicated by the WWHM. In both instances there should be at least one foot of hydraulic head above the invert of the upstream end of the collector pipe. (King County, 1998)
  - Internal diameters of underdrain pipes should be a minimum of six inches having two rows of ½-inch holes spaced 6 inches apart longitudinally (maximum), with rows 120 degrees apart (laid with holes downward). Maximum perpendicular distance between two feeder pipes must be 15 feet. All piping is to be schedule 40 PVC or greater wall thickness. Drain piping could be installed in basin and trench configurations.
  - Main collector underdrain pipe should be at a slope of 0.5 percent minimum. (King County, 1998)
  - A geotextile fabric (specifications in Appendix V-C) must be used between the sand layer and drain rock or gravel and placed so that 1-inch of drain rock/gravel is above the fabric. Drain rock should be 0.75-1.5 inch rock or gravel backfill, washed free of clay and organic material. (King County, 1998)

Cleanout wyes with caps or junction boxes must be provided at both ends of the collector pipes. Cleanouts must extend to the surface of the filter. A valve box must be provided for access to the cleanouts. Access for cleaning all underdrain piping should be provided. This may consist of installing cleanout ports, which tee into the underdrain system and surface above the top of the sand bed. To facilitate



maintenance of the sand filter an inlet shutoff/bypass valve is recommended.

*Note: Other equivalent energy dissipaters can be used if needed.*

4. Sand specification: The sand in a filter must consist of a medium sand meeting the size gradation (by weight) given in Table 8.1 below. The contractor must obtain a grain size analysis from the supplier to certify that the No. 100 and No. 200 sieve requirements are met. *(Note: Standard backfill for sand drains, Wa. Std. Spec. 9-03.13, does not meet this specification and should not be used for sand filters.)*
5. Impermeable Liners for Sand Bed Bottom: Impermeable liners are generally required for soluble pollutants such as metals and toxic organics and where the underflow could cause problems with structures. Impermeable liners may be clay, concrete or geomembrane. Clay liners should have a minimum thickness of 12 inches and meet the specifications give in Table 8.2:
  - If a geomembrane liner is used it should have a minimum thickness of 30 mils and be ultraviolet resistant. The geomembrane liner should be protected from puncture, tearing, and abrasion by installing geotextile fabric on the top and bottom of the geomembrane.
  - Concrete liners may also be used for sedimentation chambers and for sedimentation and sand filtration basins less than 1,000 square feet in area. Concrete should be 5 inches thick Class A or better and should be reinforced by steel wire mesh. The steel wire mesh should be 6 gauge wire or larger and 6-inch by 6-inch mesh or smaller. An "Ordinary Surface Finish" is required. When the underlying soil is clay or has an unconfined compressive strength of 0.25 ton per square foot or less, the concrete should have a minimum 6-inch compacted aggregate base. This base must consist of coarse sand and river stone, crushed stone or equivalent with diameter of 0.75- to 1-inch.
  - If an impermeable liner is not required then a geotextile fabric liner should be installed that retains the sand and meets the specifications listed in Appendix V-C unless the basin has been excavated to bedrock.
  - If an impermeable liner is not provided, then an analysis should be made of possible adverse effects of seepage zones on groundwater, and near building foundations, basements, roads, parking lots and sloping sites. Sand filters without impermeable liners should not be built on fill sites and should be located at least 20-feet downslope and 100-feet upslope from building foundations.
6. Include an access ramp with a slope not to exceed 7:1, or equivalent, for maintenance purposes at the inlet and the outlet of a surface filter. Consider an access port for inspection and maintenance.

7. Side slopes for earthen/grass embankments should not exceed 3:1 to facilitate mowing.
8. High groundwater may damage underground structures or affect the performance of filter underdrain systems. There should be sufficient clearance (at least 2 feet is recommended) between the seasonal high groundwater level (highest level of ground water observed) and the bottom of the sand filter to obtain adequate drainage.

## 8.7 Construction Criteria

No runoff should enter the sand filter prior to completion of construction and approval of site stabilization by the responsible inspector. Construction runoff may be routed to a pretreatment sedimentation facility, but discharge from sedimentation facilities should by-pass downstream sand filters. Careful level placement of the sand is necessary to avoid formation of voids within the sand that could lead to short-circuiting (particularly around penetrations for underdrain cleanouts), and to prevent damage to the underlying geomembranes and underdrain system. Over-compaction should be avoided to ensure adequate filtration capacity. Sand is best placed with a low ground pressure bulldozer (4 psig or less). After the sand layer is placed water settling is recommended. Flood the sand with 10-15 gallons of water per cubic foot of sand.

## 8.8 Maintenance Criteria

Inspections of sand filters and pretreatment systems should be conducted every 6 months and after storm events as needed during the first year of operation, and annually thereafter if filter performs as designed. Repairs should be performed as necessary. Suggestions for maintenance include:

- Accumulated silt and debris on top of the sand filter should be removed when their depth exceeds 1/2-inch. The silt should be scraped off during dry periods with steel rakes or other devices. Once sediment is removed, the design permeability of the filtration media can typically be restored by then striating the surface layer of the media. Finer sediments that have penetrated deeper into the filtration media can reduce the permeability to unacceptable levels, necessitating replacement of some or all of the sand.
- Sand replacement frequency is not well established and will depend on suspended solids levels entering the filter (the effectiveness of the pretreatment BMP can be a significant factor).
- Frequent overflow into the spillway or overflow structure or slow drawdown are indicators of plugging problems. A sand filter should empty in 24 hours following a storm event (24 hours for the pre-settling chamber), depending on pond depth. If the hydraulic conductivity drops to 1-inch per hour corrective action is needed, e.g.:
  - Scraping the top layer of fine-grain sediment accumulation (mid-winter scraping is suggested)

- Removal of thatch
- Aerating the filter surface
- Tilling the filter surface (late-summer rototilling is suggested)
- Replacing the top 4 inches of sand.
- Inspecting geotextiles for clogging
- Rapid drawdown in the sand bed (greater than 12 inches per hour) indicates short-circuiting of the filter. Inspect the cleanouts on the underdrain pipes and along the base of the embankment for leakage.
- Drawdown tests for the sand bed could be conducted, as needed, during the wet season. These tests can be conducted by allowing the filter to fill (or partially fill) during a storm event, then measuring the decline in water level over a 4-8 hour period. An inlet and an underdrain outlet valve would be necessary to conduct such a test.
- Formation of rills and gullies on the surface of the filter indicates improper function of the inlet flow spreader, or poor sand compaction. Check for accumulation of debris on or in the flow spreader and refill rills and gullies with sand.
- Avoid driving heavy equipment on the filter to prevent compaction and rut formation.

## **BMP T8.10 Sand Filter Vault**

### **Description: (Figures 8.6a and 8.6b)**

A sand filter vault is similar to an open sand filter except that the sand layer and underdrains are installed below grade in a vault. It consists of presettling and sand filtration cells.

### **Applications and Limitations**

- Use where space limitations preclude above ground facilities
- Not suitable where high water table and heavy sediment loads are expected
- An elevation difference of 4 feet between inlet and outlet is needed

### **Additional Design Criteria for Vaults**

- Vaults may be designed as off-line systems or on-line for small drainages.
- In an off-line system a diversion structure should be installed to divert the design flow rate into the sediment chamber and bypass the remaining flow to detention/retention (if necessary to meet Minimum Requirement #7), or to surface water.
- Optimize sand inlet flow distribution with minimal sand bed disturbance. A maximum of 8-inch distance between the top of the spreader and the top of the sand bed is suggested. Flows may enter the sand bed by spilling over the top of the wall into a flow spreader pad or alternatively a pipe and manifold system may be used. Any pipe and manifold system must retain the required dead storage volume in the first cell, minimize turbulence, and be readily maintainable.
- If an inlet pipe and manifold system is used, the minimum pipe size should be 8 inches. Multiple inlets are recommended to minimize turbulence and reduce local flow velocities.
- Erosion protection must be provided along the first foot of the sand bed adjacent to the spreader. Geotextile fabric secured on the surface of the sand bed, or equivalent method, may be used.
- The filter bed should consist of a sand top layer, and a geotextile fabric second layer with an underdrain system.
- Design the presettling cell for sediment collection and removal. A V-shaped bottom, removable bottom panels, or equivalent sludge handling system should be used. One-foot of sediment storage in the presettling cell must be provided.
- The pre-settling chamber must be sealed to trap oil and trash. This chamber is usually connected to the sand filtration chamber through an invert elbow to protect the filter surface from oil and trash.

- If a retaining baffle is necessary for oil/floatables in the presettling cell, it must extend at least one foot above to one foot below the design flow water level. Provision for the passage of flows in the event of plugging must be provided. Access opening and ladder must be provided on both sides of the baffle.
- To prevent anoxic conditions, a minimum of 24 square feet of ventilation grate should be provided for each 250 square feet of sand bed surface area. For sufficient distribution of airflow across the sand bed, grates may be located in one area if the sand filter is small, but placement at each end is preferred. Small grates may also be dispersed over the entire sand bed area.
- Provision for access is the same as for wet vaults. Removable panels must be provided over the entire sand bed.
- Sand filter vaults must conform to the materials and structural suitability criteria specified for wet vaults.
- Provide a sand filter inlet shutoff/bypass valve for maintenance
- A geotextile fabric over the entire sand bed may be installed that is flexible, highly permeable, three-dimensional matrix, and adequately secured. This is useful in trapping trash and litter.

## **BMP T8.20 Linear Sand Filter**

### **Description: (Figure 8.7)**

Linear sand filters are typically long, shallow, two-celled, rectangular vaults. The first cell is designed for settling coarse particles, and the second cell contains the sand bed. Stormwater flows into the second cell via a weir section that also functions as a flow spreader.

### **Application and Limitations**

- Applicable in long narrow spaces such as the perimeter of a paved surface.
- As a part of a treatment train as downstream of a filter strip, upstream of an infiltration system, or upstream of a wet pond or a biofilter for oil control.
- To treat small drainages (less than 2 acres of impervious area).
- To treat runoff from high-use sites for TSS and oil/grease removal, if applicable.

### **Additional Design Criteria for Linear Sand Filters**

- The two cells should be divided by a divider wall that is level and extends a minimum of 12 inches above the sand bed.
- Stormwater may enter the sediment cell by sheet flow or a piped inlet.
- The width of the sand cell must be 1-foot minimum to 15 feet maximum.
- The sand filter bed must be a minimum of 12 inches deep and have an 8-inch layer of drain rock with perforated drainpipe beneath the sand layer.
- The drainpipe must be 6-inch diameter minimum and be wrapped in geotextile and sloped a minimum of 0.5 percent.
- Maximum sand bed ponding depth: 1-foot.
- Must be vented as for sand filter vaults.
- Linear sand filters must conform to the materials and structural suitability criteria specified for wet vaults.
- Set sediment cell width as follows:

Sand filter width, (w) inches	12-24	24-48	48-72	72+
Sediment cell width, inches	12	18	24	w/3

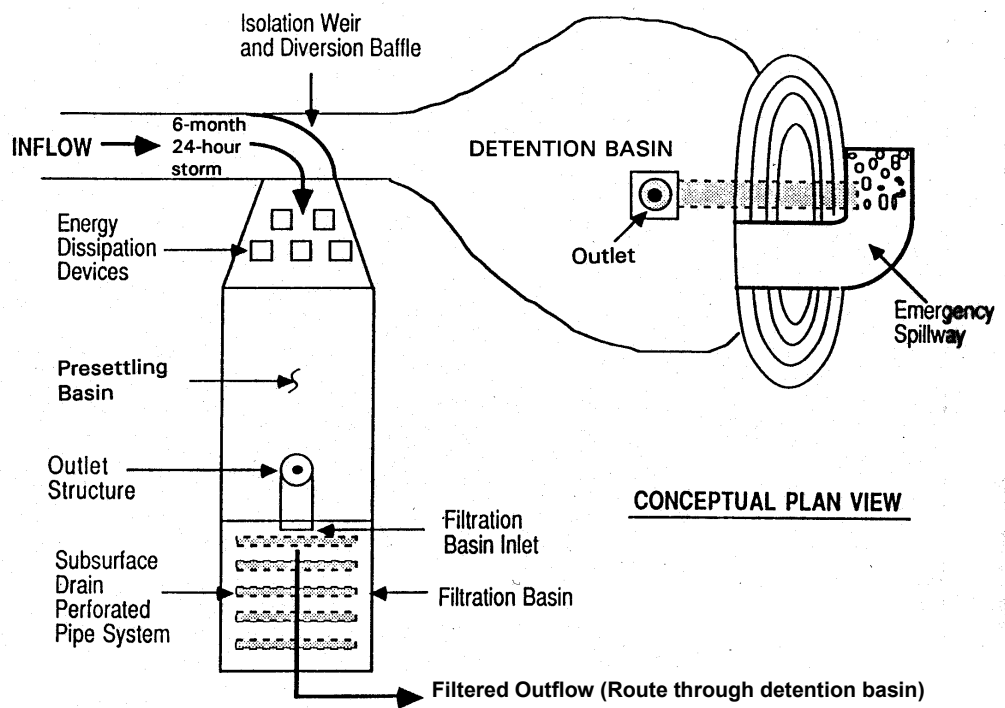
<b>Table 8.1 -- Sand Medium Specification</b>	
<b>U.S. Sieve Number</b>	<b>Percent Passing</b>
4	95-100
8	70-100
16	40-90
30	25-75
50	2-25
100	<4
200	<2

Source: King County Surface Water Design Manual, September 1998

<b>Table 8.2 - Clay Liner Specifications</b>			
<b>Property</b>	<b>Test Method</b>	<b>Unit</b>	<b>Specification</b>
Permeability	ASTM D-2434	cm/sec	$1 \times 10^{-6}$ max.
Plasticity Index of Clay	ASTM D-423 & D-424	percent	Not less than 15
Liquid Limit of Clay	ASTM D-2216	percent	Not less than 30
Clay Particles Passing	ASTM D-422	percent	Not less than 30
Clay Compaction	ASTM D-2216	percent	95% of Standard Proctor Density

Source: City of Austin, 1988

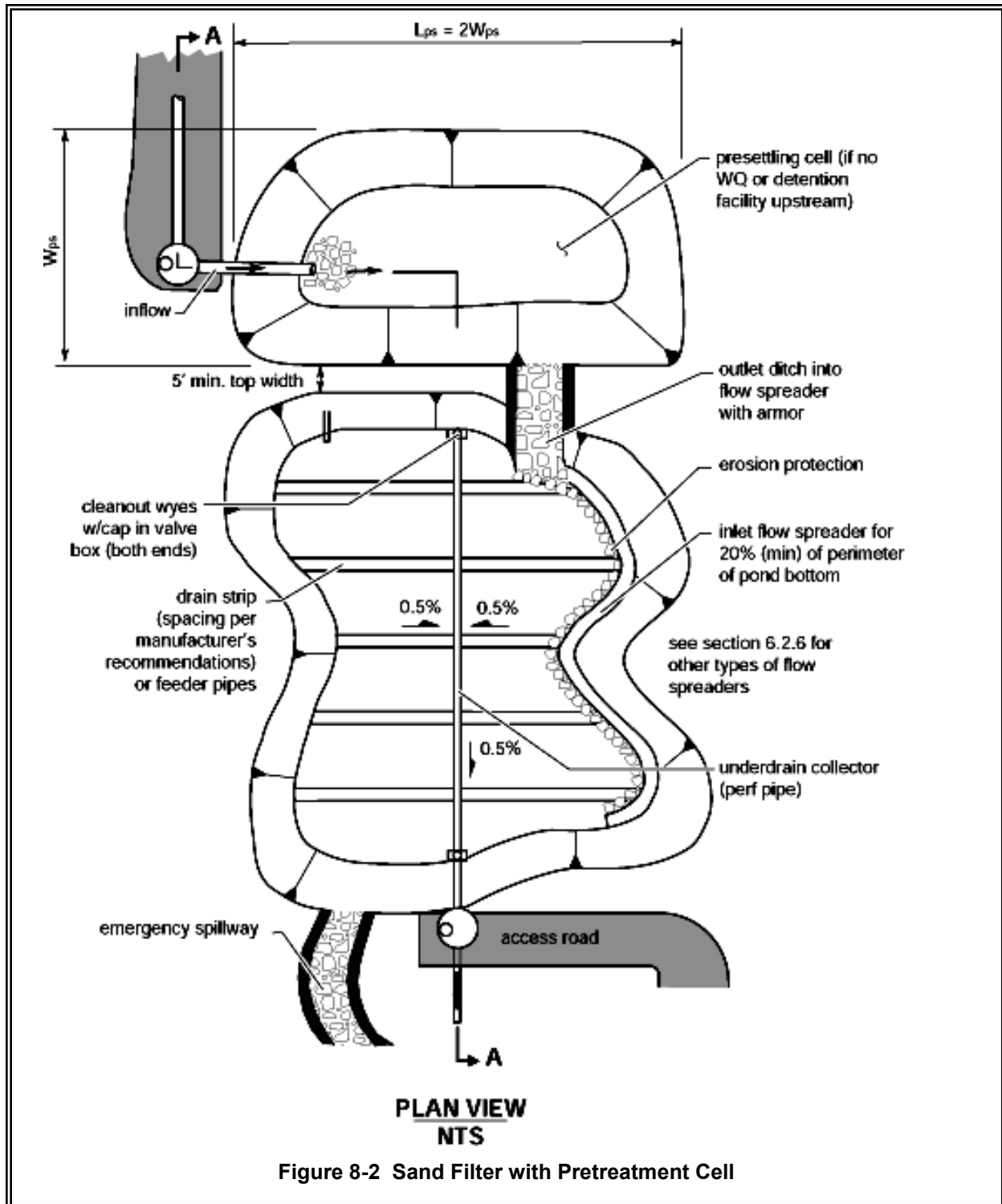
**SAND FILTRATION BASIN PRECEDED BY PRESETTLING BASIN**

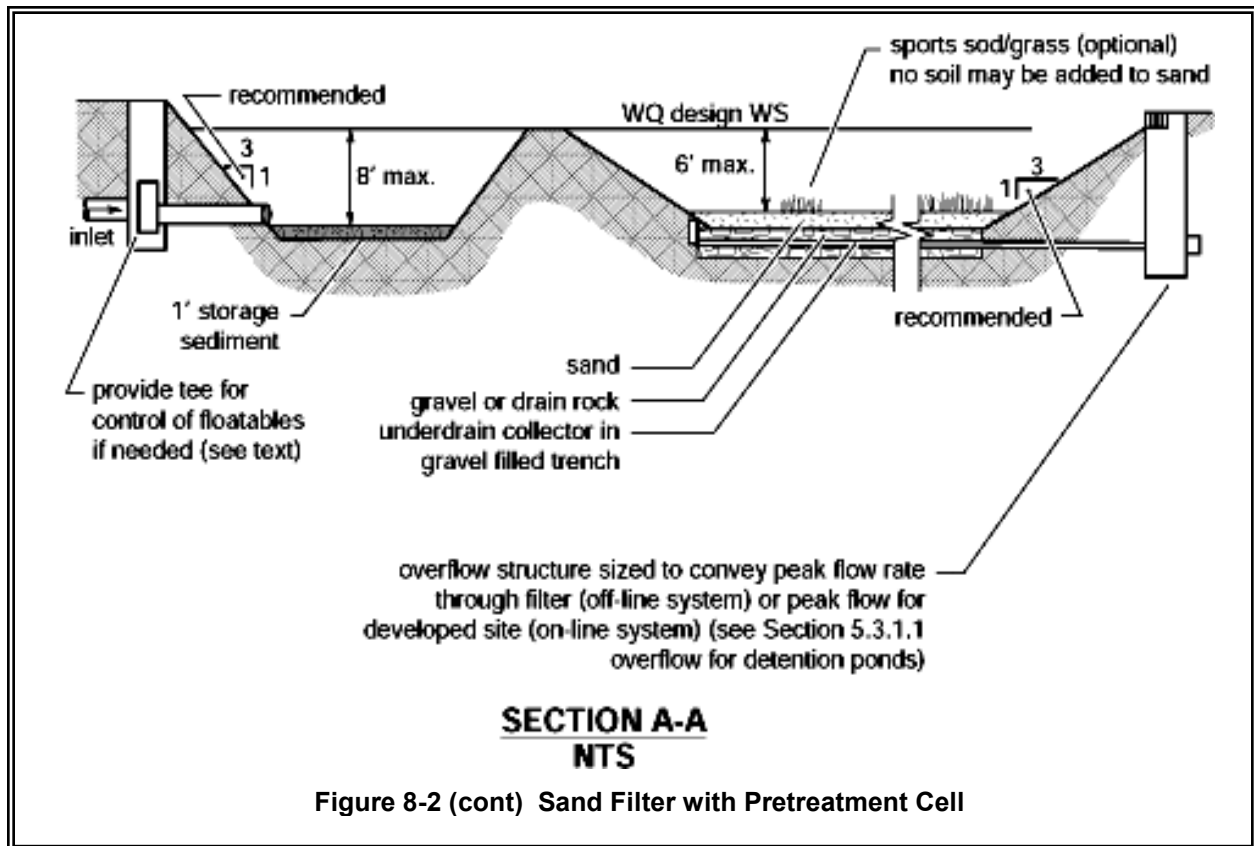


**Figure 8-1 Sand Filtration Basin Preceded by Presettling Basin (Variation of a Basic Sand Filter)**

Source: City of Austin







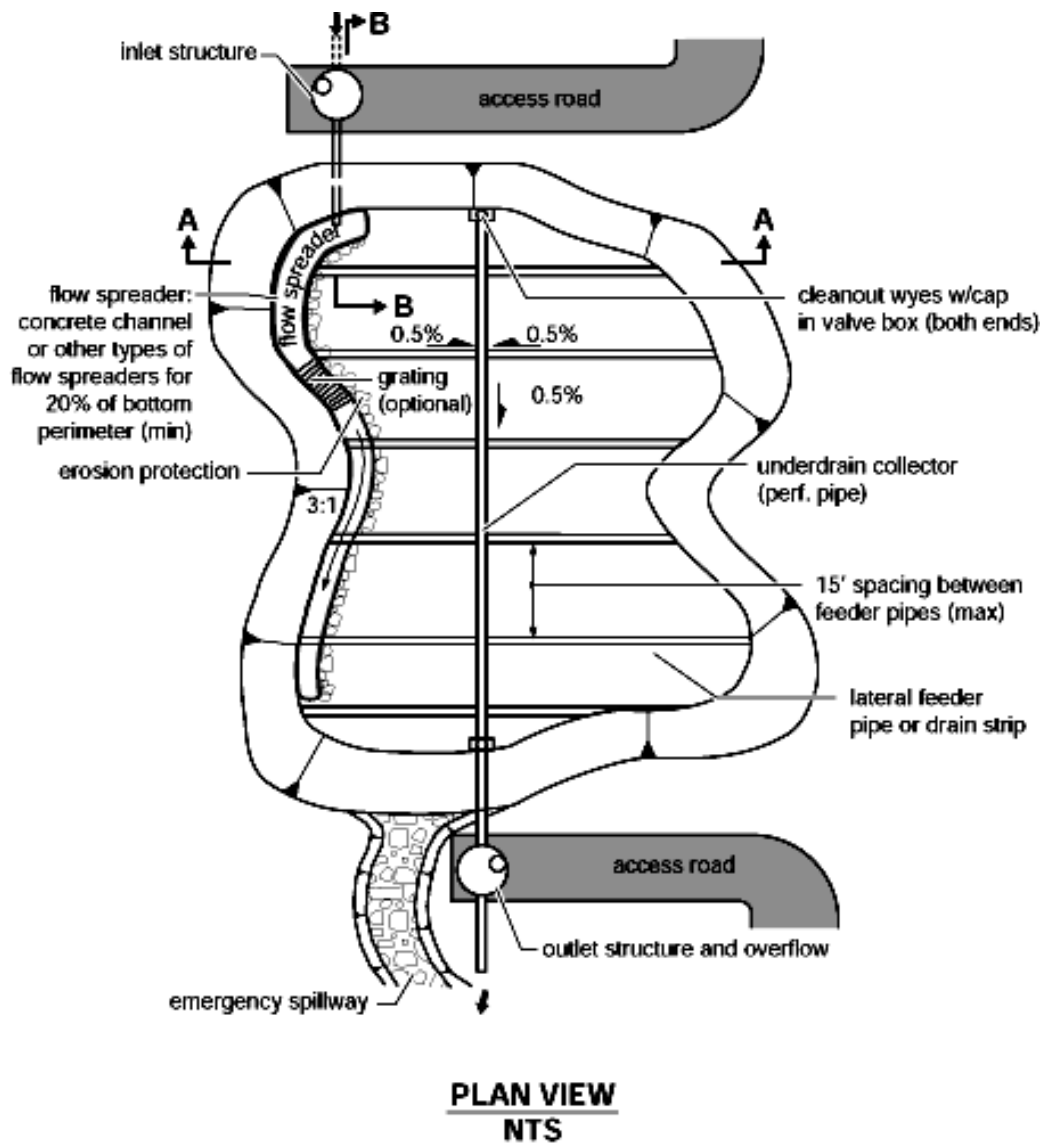


Figure 8-3 Sand Filter with Level Spreader

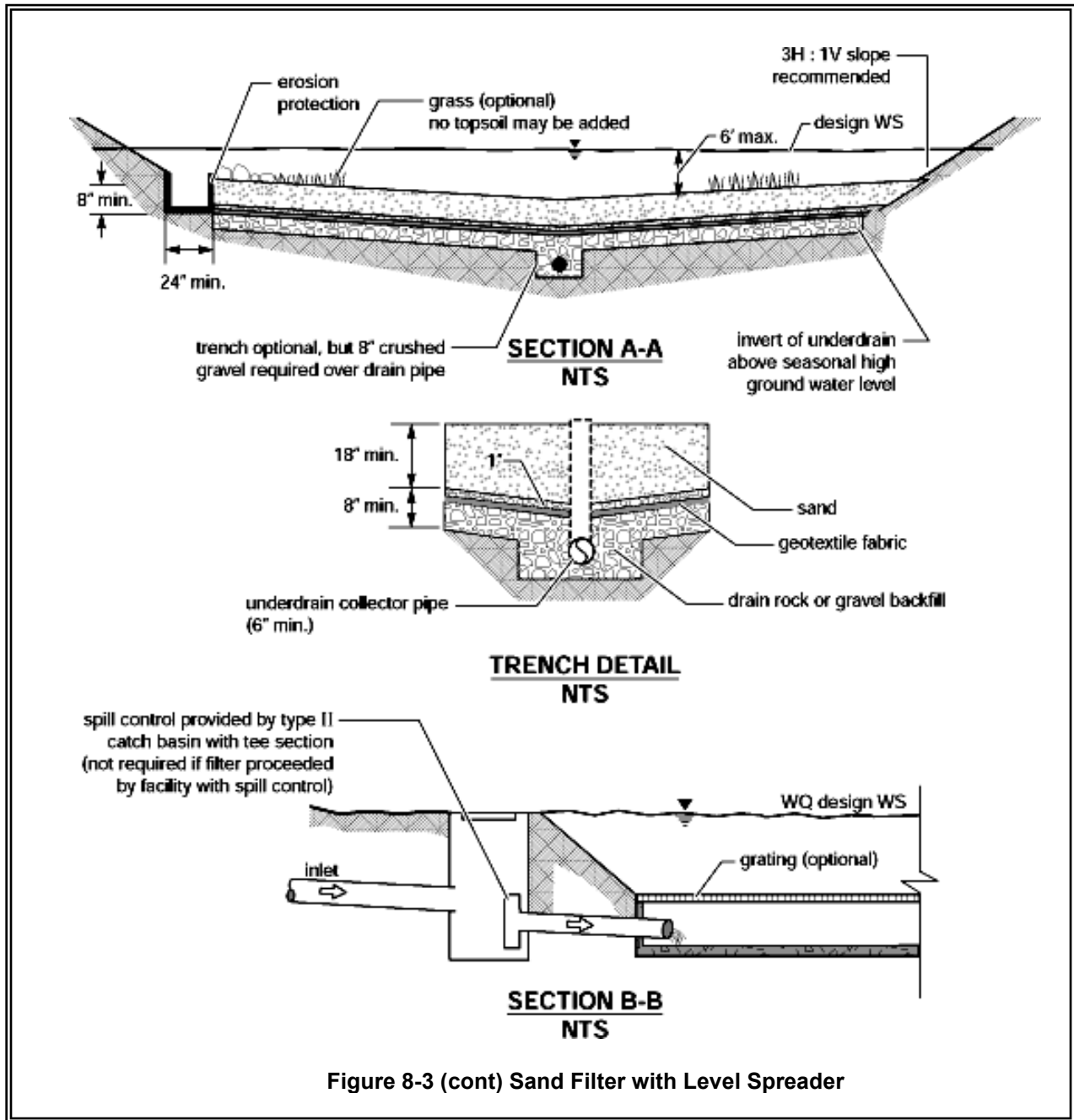
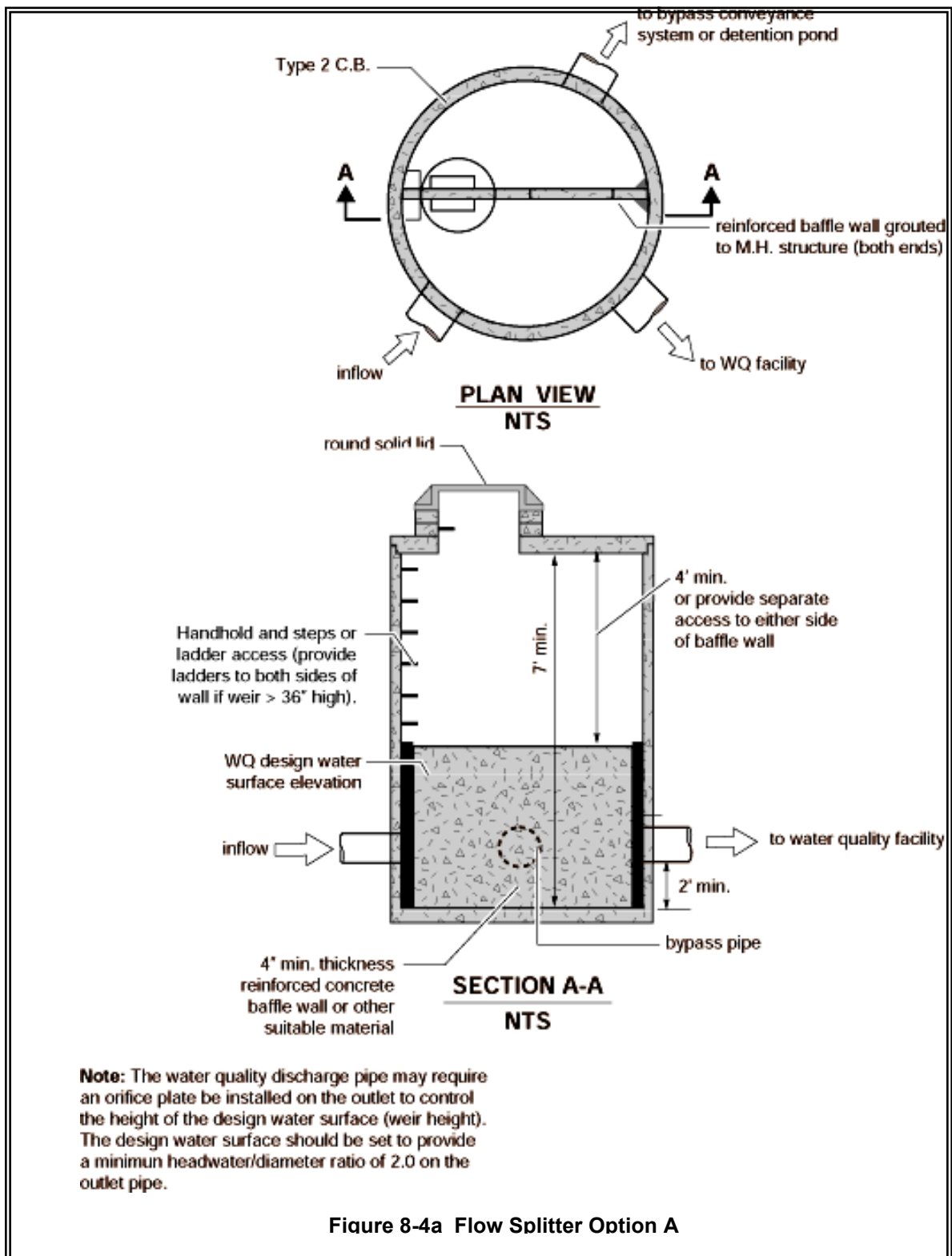
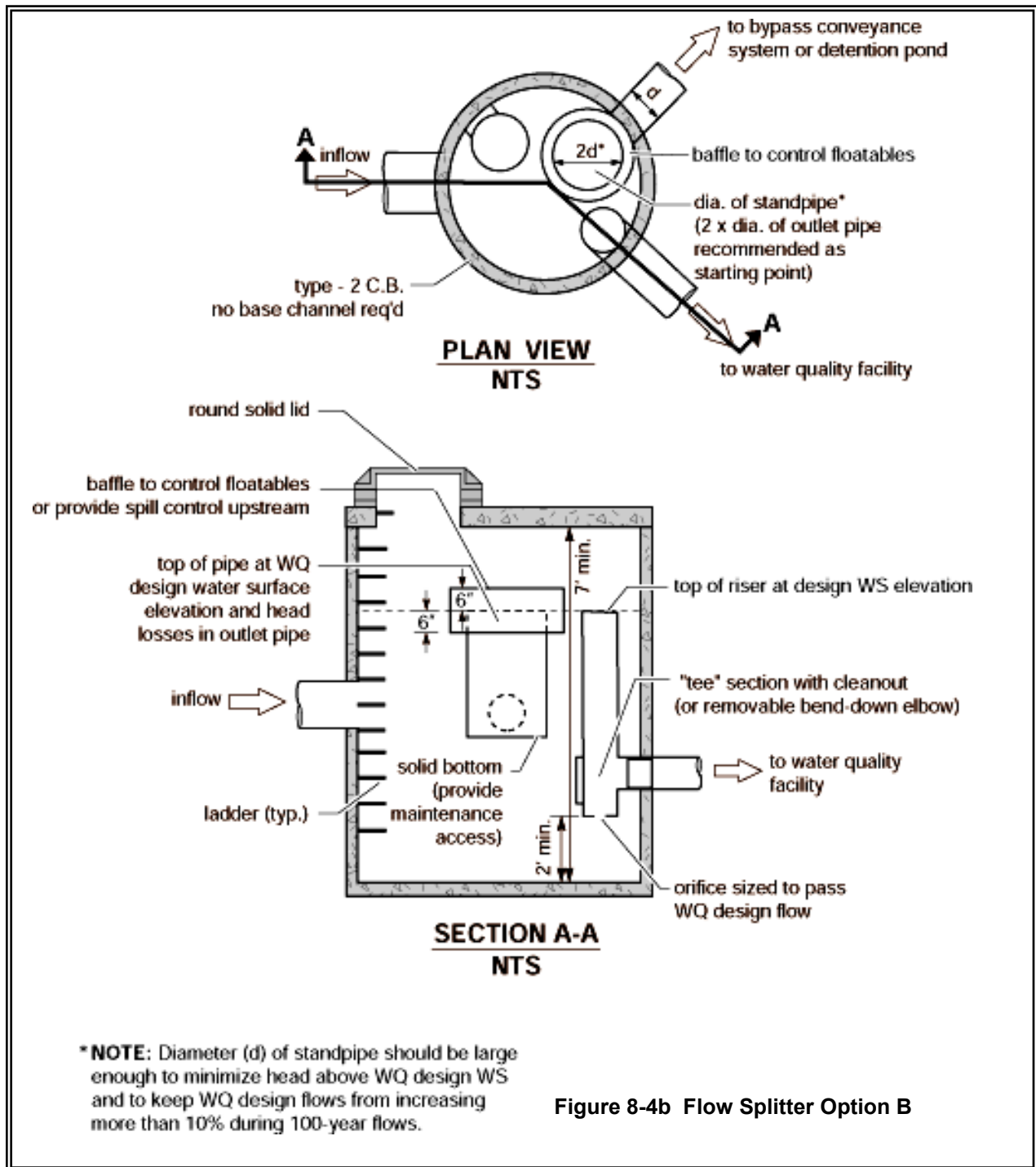
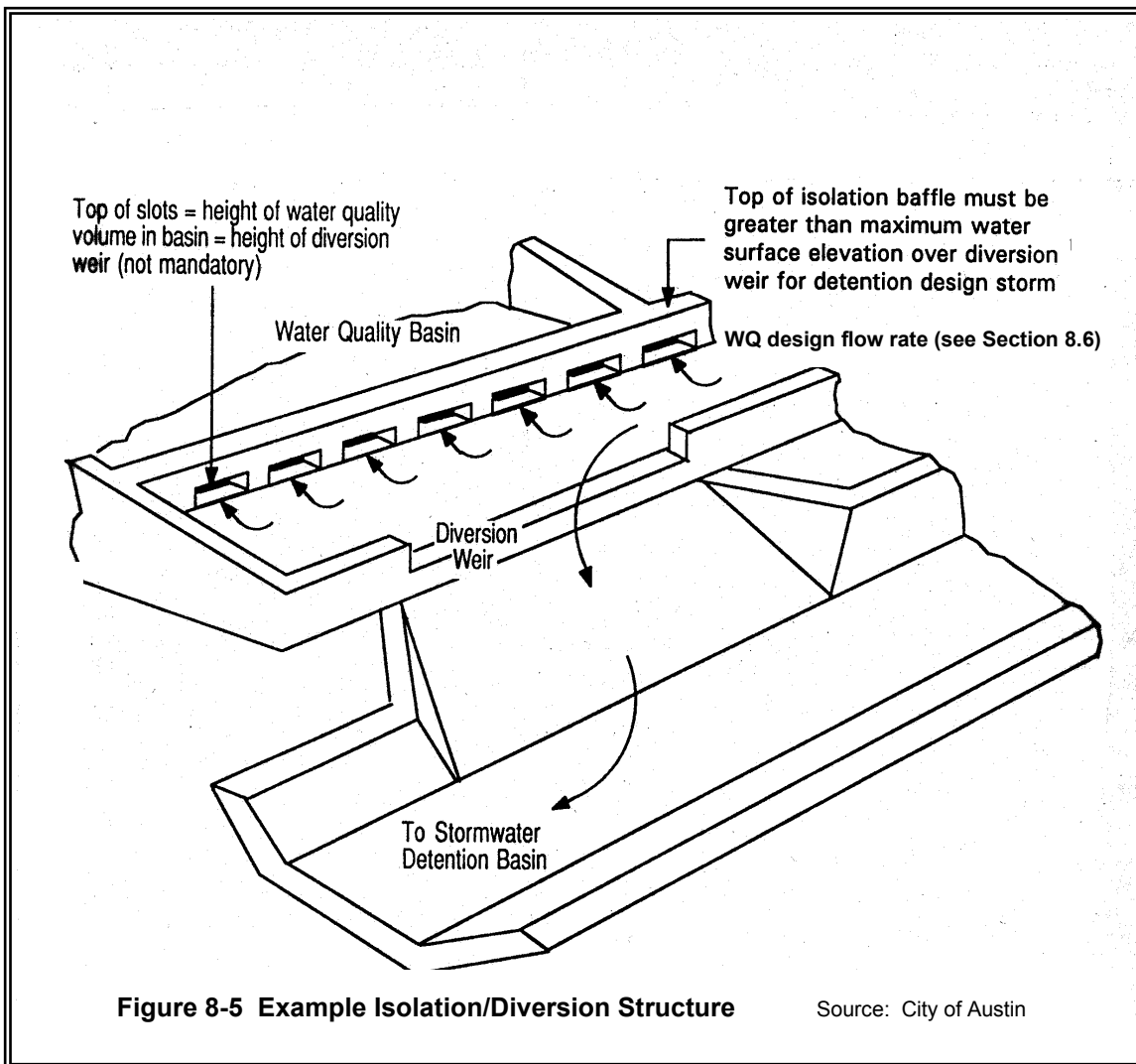
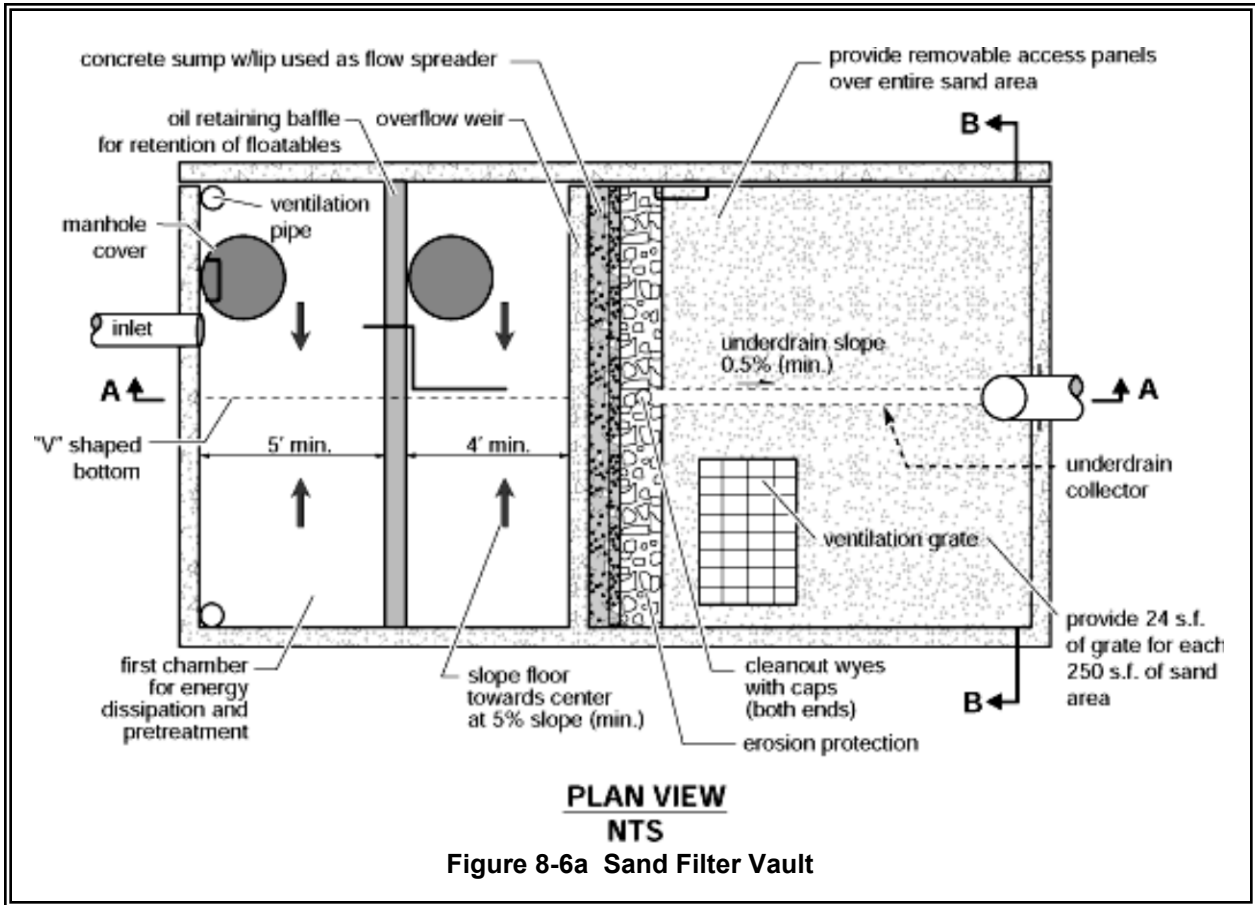


Figure 8-3 (cont) Sand Filter with Level Spreader











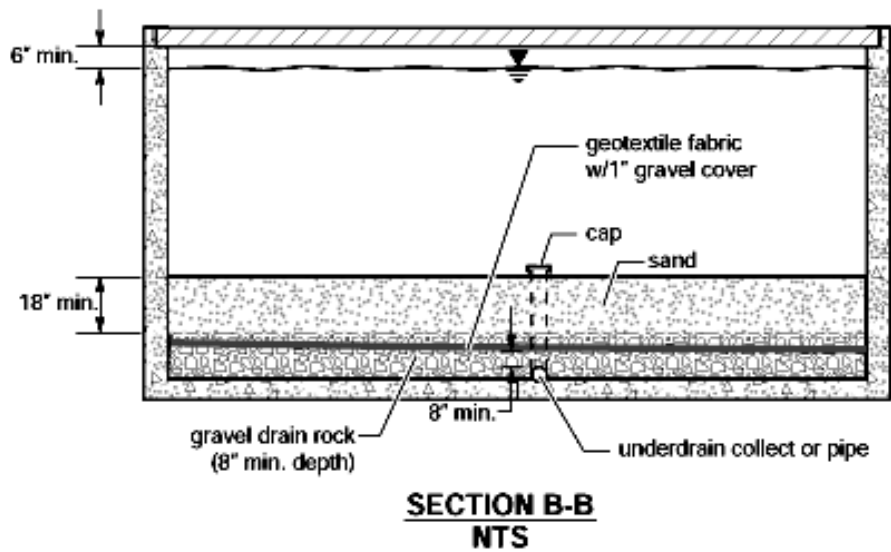
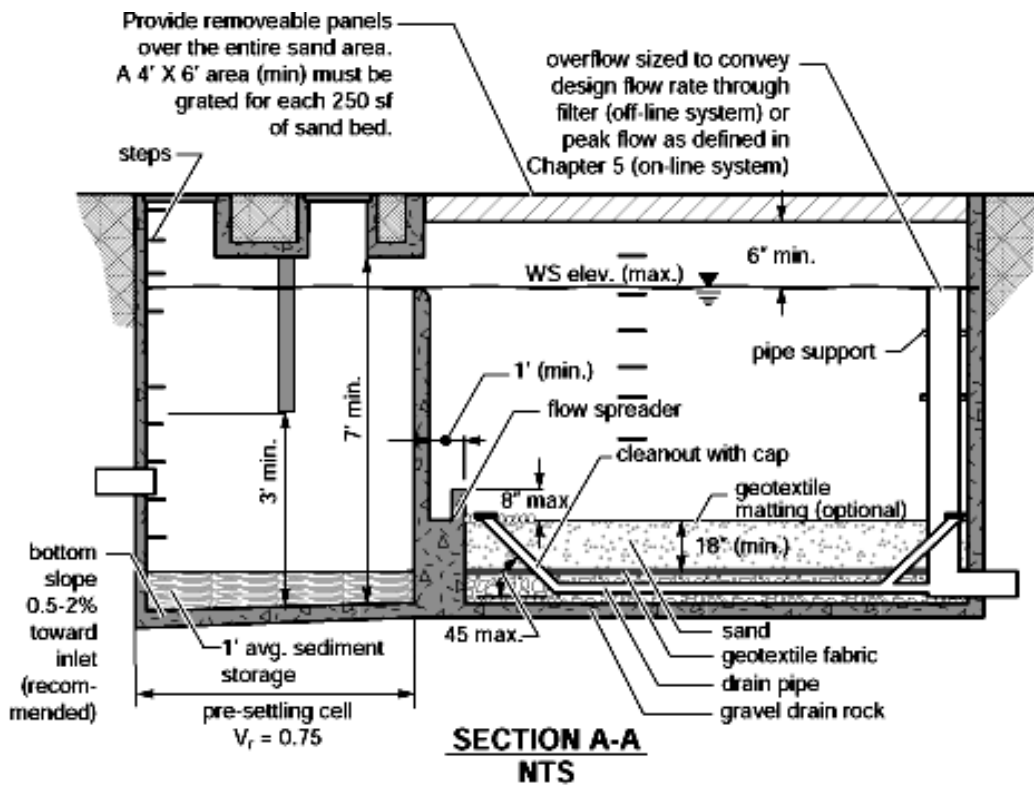
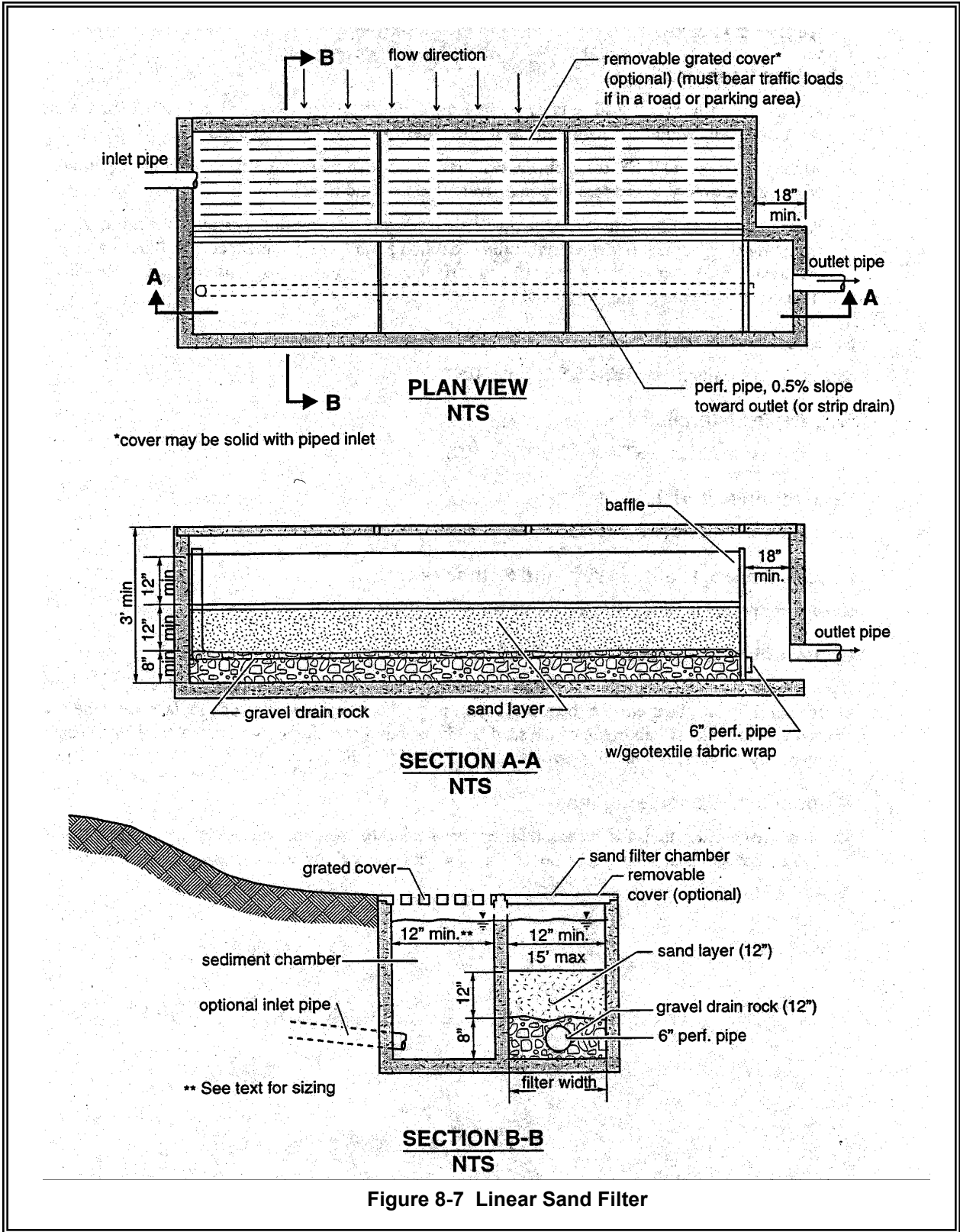


Figure 8-6b Sand Filter Vault (cont)



# Chapter 9 – Biofiltration Treatment Facilities

---

*Note: Figures in Chapter 9 are courtesy of King County, except as noted.*

This Chapter addresses five Best Management Practices (BMPs) that are classified as biofiltration treatment facilities.

Biofilters are vegetated treatment systems (typically grass) that remove pollutants by means of sedimentation, filtration, soil sorption, and/or plant uptake. They are typically configured as swales or flat filter strips.

## 9.1 Purpose

The BMPs discussed in this Chapter are designed to remove low concentrations and quantities of total suspended solids (TSS), heavy metals, petroleum hydrocarbons, and/or nutrients from storm water.

## 9.2 Applications

A biofilter can be used as a basic treatment BMP for contaminated storm water runoff from roadways, driveways, parking lots, and highly impervious ultra-urban areas or as the first stage of a treatment train. In cases where hydrocarbons, high TSS, or debris would be present in the runoff, such as high-use sites, a pretreatment system for those components would be necessary. Off-line location is preferred to avoid flattening vegetation and the erosive effects of high flows. Biofilters should be considered in retrofit situations where appropriate. (Center for Watershed Protection, 1998)

## 9.3 Site Suitability

The following factors must be considered for determining site suitability:

- Target pollutants are amenable to biofilter treatment.
- Accessibility for operation and maintenance.
- Suitable growth environment (soil, etc.) for the vegetation.
- Adequate siting for a pre-treatment facility if high petroleum hydrocarbon levels (oil/grease) or high TSS loads could impair treatment capacity or efficiency.
- If the biofilter can be impacted by snowmelts and ice, refer to Caraco and Claytor for additional design criteria (USEPA, 1997).

## 9.4 Best Management Practices

The following five Biofiltration Treatment Facilities BMPs are discussed in this Chapter:

- BMP T9.10 – Basic Biofiltration Swale
- BMP T9.20 – Wet Biofiltration Swale
- BMP T9.30 – Continuous Inflow Biofiltration Swale
- BMP T9.40 – Basic Filter Strip
- BMP T9.50 – Narrow Area Filter Strip

## **BMP T9.10 Basic Biofiltration Swale**

### ***Description:***

Biofiltration swales are typically shaped as a trapezoid or a parabola as shown in Figure 9.1.

### ***Limitations:***

Data suggest that the performance of biofiltration swales is highly variable from storm to storm. It is therefore recommended that treatment methods providing more consistent performance, such as sand filters and wet ponds, be considered first. Swales downstream of devices of equal or greater effectiveness can convey runoff but should not be expected to offer a treatment benefit. (Horner, 2000)

### ***Design Criteria:***

- *Design criteria are specified in Table 9.1.* A 22-minute hydraulic residence time is used at the peak 15 minute Water Quality Design Flow Rate (Q) representing 91% runoff volume as determined by the Western Washington Hydrology Model (WWHM) (see Volume I).
- Check the hydraulic capacity/stability for inflows greater than design flows. Bypass high flows, or control release rates into the biofilter, if necessary.
- Install level spreaders (min. 1-inch gravel) at the head and every 50 feet in swales of  $\geq 4$  feet width. Include sediment cleanouts (weir, settling basin, or equivalent) at the head of the biofilter as needed.
- Use energy dissipators (riprap) for increased downslopes.

**Guidance for Bypassing Off-line Facilities:** Swales designed in an off-line mode using the new water quality design flow rate and hydraulic residence time are allowed to bypass storm water at a lower flow rate than allowed in the 1992 manual. Ecology does not know if this will increase or decrease the annual average pollutant removal because no definitive information is known concerning the performance of properly designed swales at flow rates between the new water quality design flow rate and the old water quality design flow rate. This manual will be updated when new information is available.

### ***Sizing Procedure for Biofiltration Swales:***

This guide provides biofilter swale design procedures in full detail, along with examples.

### **Preliminary Steps (P)**

**P-1.** Determine the Water Quality design flow rate (Q) in 15-minute time-steps using the WWHM. Until the WWHM provides that information directly, estimate the water quality design flow rate using the 2-year return frequency flow predicted by the WWHM and Table 4.1.

**P-2.** Establish the longitudinal slope of the proposed biofilter.

**P-3.** Select a vegetation cover suitable for the site. Refer to Tables 9.2, 9.3, 9.4, and 9.5 (in text) to select vegetation for Western Washington.

**Design Calculations for Biofiltration Swale:**

There are a number of ways of applying the design procedure introduced by Chow (Chow, 1959). These variations depend on the order in which steps are performed, what constants are established at the beginning of the process and which ones are calculated, and what values are assigned to the variables selected initially.

The procedure recommended here is an adaptation appropriate for biofiltration applications of the type being installed in the Puget Sound region. This procedure reverses Chow's order, designing first for capacity and then for stability. The capacity analysis emphasizes the promotion of biofiltration, rather than transporting flow with the greatest possible hydraulic efficiency. Therefore, it is based on criteria that promote sedimentation, filtration, and other pollutant removal mechanisms. Because these criteria include a lower maximum velocity than permitted for stability, the biofilter dimensions usually do not have to be modified after a stability check.

**Design Steps (D):**

**D-1.** Select the type of vegetation, and design depth of flow (based on frequency of mowing and type of vegetation) (see Table 9.1).

**D-2.** Select a value of Manning's n (Table 9.1 with footnote #3).

**D-3.** Select swale shape-typically trapezoidal or parabolic.

**D-4.** Use Manning's equation and first approximations relating hydraulic radius and dimensions for the selected swale shape to obtain a working value of a biofilter width dimension:

$$Q = \frac{1.49AR^{0.67}s^{0.5}}{n} \quad (1)$$

$$A_{\text{rectangle}} = Ty \quad (2)$$

$$R_{\text{rectangle}} = \frac{Ty}{T + 2y} \quad (3)$$

Where:

- Q = Water Quality Design flow rate in 15-minute time steps based on WWHM, (ft<sup>3</sup>/s, cfs) (See Appendix I-B, Volume I)
- n = Manning's n (dimensionless)
- s = Longitudinal slope as a ratio of vertical rise/horizontal run (dimensionless)
- A = Cross-sectional area (ft<sup>2</sup>)

- R = Hydraulic radius (ft)
- T = top width of trapezoid or width of a rectangle (ft)
- y = depth of flow (ft)
- b = bottom width of trapezoid (ft)

If equations 2 and 3 are substituted into equation 1 and solved for T, complex equations result that are difficult to solve manually. However, approximate solutions can be found by recognizing that  $T \gg y$  and  $Z^2 \gg 1$ , and that certain terms are nearly negligible. The approximation solutions for rectangular and trapezoidal shapes are:

$$R_{\text{rectangle}} \approx y, \quad R_{\text{trapezoid}} \approx y, \quad R_{\text{parabolic}} \approx 0.67y, \quad R_v \approx 0.5y$$

Substitute  $R_{\text{trapezoid}}$  and  $A_{\text{trapezoid}} = by + Zy^2$  into Equation 1, and solve for the bottom width b (trapezoidal swale):

$$b \approx \frac{2.5Qn}{1.49y^{1.67} s^{0.5}} - Zy$$

For a trapezoid, select a side slope Z of at least 3. Compute b and then top width T, where  $T = b + 2yZ$ . (*Note: Adjustment factor of 2.5 accounts for the differential between Water Quality design flow rate and the SBUH design flow.*)

If b for a swale is greater than 10 ft, either investigate how Q can be reduced, divide the flow by installing a low berm, or arbitrarily set  $b = 10$  ft and continue with the analysis. For other swale shapes refer to Fig. 9.5.

**D-5.** Compute A:

$$A_{\text{rectangle}} = Ty \quad \text{or} \quad A_{\text{trapezoid}} = by + Zy^2$$

$$A_{\text{filter strip}} = Ty$$

**D-6.** Compute the flow velocity at design flow rate:

$$V = \frac{Q}{A}$$

If  $V > 1.0$  ft/sec (or  $V > 0.5$  ft/sec for a filter strip), repeat steps D-1 to D-6 until the condition is met. A velocity greater than 1.0 ft/sec was found to flatten grasses, thus reducing filtration. A velocity lower than this maximum value will allow a 22-minute hydraulic residence time criterion in a shorter biofilter. If the value of V suggests that a longer biofilter will be needed than space permits, investigate how Q can be reduced, or increase y and/or T (up to the allowable maximum values) and repeat the analysis.

**D-7.** Compute the swale length (L, ft)

$$L = Vt \text{ (60 sec/min)}$$

Where: t = hydraulic residence time (min)

Use t = 22 minutes for this calculation (use t = 44 minutes for a continuous inflow biofiltration swale). If a biofilter length is greater than the space permits, follow the advice in step D-6.

If a length less than 100 feet results from this analysis, increase it to 100 feet, the minimum allowed. In this case, it may be possible to save some space in width and still meet all criteria. This possibility can be checked by computing V in the 100 ft biofilter for t = 22 minutes, recalculating A (if  $V < 1.0$  ft/sec) and recalculating T.

**D-8.** If there is still not sufficient space for the biofilter, the local government and the project proponent should consider the following solutions (listed in order of preference):

- 1) Divide the site drainage to flow to multiple biofilters.
- 2) Use infiltration to provide lower discharge rates to the biofilter (only if the criteria and Site Suitability Criteria in Chapter 7 are met).
- 3) Increase vegetation height and design depth of flow (note: the design must ensure that vegetation remains standing during design flow).
- 4) Reduce the developed surface area to gain space for biofiltration.
- 5) Increase the longitudinal slope.
- 6) Increase the side slopes.
- 7) Nest the biofilter within or around another BMP.

***Check for Stability (Minimizing Erosion):***

The stability check must be performed for the combination of highest expected flow and least vegetation coverage and height. A check is not required for biofiltration swales that are located "off-line" from the primary conveyance/detention system, i.e., when flows in excess of the water quality design flow rate bypass the biofilter. Off-line is the desired configuration.

Maintain the same units as in the biofiltration capacity analysis.

**SC-1.** Unless runoff at rates higher than the water quality design flow rate (or at rates higher than 2.5x the water quality design flow rate as an alternative allowed in this guidance) bypass the biofilter, perform the stability check for the 100-year, return frequency flow using 15-minute time steps using an approved continuous runoff model. Until WWHM peak flow rates in 15-minute time steps are available, the designer can use the WWHM 100-yr. hourly peak flows multiplied by an adjustment factor of 1.6 to approximate peak flows in 15-minute time steps.

**SC-2.** Estimate the vegetation coverage ("good" or "fair") and height on the first occasion that the biofilter will receive flow, or whenever the coverage and height will be least. Avoid flow introduction during the vegetation establishment period by timing planting or bypassing.

**SC-3.** Estimate the degree of retardance from Table 9.2. When uncertain, be conservative by selecting a relatively low degree.

Establish the maximum permissible velocity for erosion prevention ( $V_{max}$ ) from Table 9.3.

***Stability Check Steps (SC):***

**SC-4.** Select a trial Manning's  $n$ . The minimum value for poor vegetation cover and low height (possibly, knocked from the vertical by high flow) is 0.033. A good initial choice under these conditions is 0.04.

**SC-5.** Refer to Figure 9.6 to obtain a first approximation for  $VR$ .

**SC-6.** Compute hydraulic radius,  $R$ , from  $VR$  in Figure 9.6 and  $V_{max}$  in Table 9.3.

**SC-7.** Use Manning's equation to solve for the actual  $VR$ .

**SC-8.** Compare the actual  $VR$  from step SC-7 and first approximation from step SC-5. If they do not agree within 5 percent, repeat steps SC-4 to SC-8 until acceptable agreement is reached. If  $n < 0.033$  is needed to get agreement, set  $n = 0.033$ , repeat step SC-7, and then proceed to step SC-9.

**SC-9.** Compute the actual  $V$  for the final design conditions:

Check to be sure  $V < V_{max}$

**SC-10.** Compute the required swale cross-sectional area,  $A$ , for stability.

**SC-11.** Compare the  $A$ , computed in step SC-10 of the stability analysis, with the  $A$  from the biofiltration capacity analysis (step D-5).

If less area is required for stability than is provided for capacity, the capacity design is acceptable. If not, use  $A$  from step SC-10 of the stability analysis and recalculate channel dimensions.

**SC-12.** Calculate the depth of flow at the stability check design flow rate condition for the final dimensions and use  $A$  from step SC-10.

**SC-13.** Compare the depth from step SC-12 to the depth used in the biofiltration capacity design (Step D-1). Use the larger of the two and add 0.5 ft. of freeboard to obtain the total depth ( $y_t$ ) of the swale. Calculate the top width for the full depth using the appropriate equation.



**SC-14.** Recalculate the hydraulic radius: (use b from Step D-4 calculated previously for biofiltration capacity, or Step SC-11, as appropriate, and  $y_t$  = total depth from Step SC-13).

**SC-15.** Make a final check for capacity based on the stability check design storm (this check will ensure that capacity is adequate if the largest expected event coincides with the greatest retardance). Use Equation 1, a Manning's n selected in step D-2, and the calculated channel dimensions, including freeboard, to compute the flow capacity of the channel under these conditions. Use R from step SC-14, above, and  $A = b(y_t) + Z(y_t)^2$  using b from Step D-4, D-15, or SC-11 as appropriate.

If the flow capacity is less than the stability check design storm flow rate, increase the channel cross-sectional area as needed for this conveyance. Specify the new channel dimensions.

**Completion Step (CO):**

**CO.** Review all of the criteria and guidelines for biofilter planning, design, installation, and operation above and specify all of the appropriate features for the application.

**Example of Design Calculations for Biofiltration Swales:**

**Preliminary Steps:**

**P-1.** Assume that the WWHM based Water Quality Design Flow Rate in 15-minute time-steps, Q, is 0.2 cfs.

**P-2.** Assume the slope (s) is 2 percent.

**P-3.** Assume the vegetation will be a grass-legume mixture and it will be infrequently mowed.

**Design for Biofiltration Swale Capacity:**

**D-1.** Set winter grass height at 5" and the design flow depth (y) at 3 inches.

**D-2.** Use  $n = 0.20$  to  $n_2 = 0.30$ .

**D-3.** Base the design on a trapezoidal shape, with a side slope  $Z = 3$ .

**D-4a.** Calculate the bottom width, b;

Where:

$n = 0.20$                        $y = 0.25$  ft  
 $Q = 0.2$  cfs                  $s = 0.02$   
 $Z = 3$

$$b \approx \frac{2.5Qn}{1.49y^{1.67}s^{0.5}} - Zy$$

$$b \approx 4.0 \text{ ft}$$

$$\text{At } n_2; b_2 = 6.5 \text{ feet}$$

**D-4b.** Calculate the top width (T):

$$T = b + 2yZ = 4.0 + [2(0.25)(3)] = 5.5 \text{ feet}$$

**D-5.** Calculate the cross-sectional area (A):

$$A = by + Zy^2 = (4.0)(0.25) + (3)(0.25^2) = 1.19 \text{ ft}^2$$

**D-6.** Calculate the flow velocity (V):

$$V = \frac{Q}{A} = 0.17 \text{ ft / sec}$$

$$0.17 < 1.0 \text{ ft/sec} \therefore \text{OK}$$

**D-7.** Calculate the Length (L):

$$L = Vt(60 \text{ sec/min})$$

$$= 0.17 (22)(60)$$

$$\text{For } t = 22 \text{ min, } L = 224 \text{ ft. at } n$$

$$\text{At } n_2; L = 145 \text{ ft.}$$

Because  $b$  is less than the maximum value, it may be possible to reduce  $L$  by increasing  $b$ . For example, if  $L = 180$  ft is desired at  $n$ , then:

$$V = \frac{L}{60t} = 0.136 \text{ ft/sec}$$

$$A = \frac{Q}{V} = 1.47 \text{ ft}^2$$

$$b = \frac{A - Zy^2}{y} = 5.13 \text{ ft at } n,$$

$$\text{At } n_2 \text{ and } L = 130 \text{ feet; } b_2 = 7.41 \text{ ft.}$$

*Note:  $b$  and  $L$  are calculated at the same flow.*

**Check for Channel Stability:**

**SC-1.** Base the check on passing the 100-year, return frequency flow (15-minute time steps) through a swale with a mixture of Kentucky bluegrass and tall fescue on loose erodible soil. Until WWHM peak flow rates in 15-minute time steps are available the designer can use the WWHM 100-yr. hourly peak flows times an adjustment factor of 1.6 to approximate peak flows in 15-minute time steps. Assume that the adjusted peak  $Q$  is 1.92 cfs.

**SC-2.** Base the check on a grass height of 3 inches with "fair" coverage (lowest mowed height and least cover, assuming flow bypasses or does not occur during grass establishment).

**SC-3.** From Table 9.2, Degree of Retardance = D (low).  
From Table 9.3 set  $V_{\max} = 5$  ft/sec

**SC-4.** Select trial Manning's  $n = 0.04$ .

**SC-5.** From Figure 9.6,  $VR_{\text{appx}} = 3$  ft<sup>2</sup>/s.

**SC-6.** Calculate R:

$$R = \frac{VR_{\text{appx}}}{V_{\max}} = 0.6 \text{ ft}$$

**SC-7.** Calculate  $VR_{\text{actual}}$ :

$$VR_{\text{actual}} = \frac{1.49}{n} R^{1.67} s^{0.5} = 2.24 \text{ ft}^2 / \text{sec}$$

**SC-8.**  $VR_{\text{actual}}$  from step SC-7 <  $VR_{\text{appx}}$  from step SC-5 by > 5%:

Select new trial  $n = 0.038$

Figure 9.6:  $VR_{\text{appx}} = 4$  ft<sup>2</sup>/s

$R = 0.8$  ft.

$VR_{\text{actual}} = 3.81$  ft<sup>2</sup>/s (within 5% of  $VR_{\text{appx}} = 4$ )

**SC-9.** Calculate V:

$$V = \frac{VR_{\text{actual}}}{R} = \frac{3.81}{0.8} = 4.76 \text{ ft} / \text{sec}$$

$V = 4.76$  ft/sec < 5 ft/sec ∴ OK

**SC-10.** Calculate Stability Area:

$$A_{\text{Stability}} = \frac{Q}{V} = \frac{1.92}{4.76} = 0.4 \text{ ft}^2$$

**SC-11.** Stability Check:

$A_{\text{Stability}} = 0.4$  ft<sup>2</sup> is less than  $A_{\text{Capacity}}$  from step D-5 ( $A_{\text{Capacity}} = 1.19$  ft<sup>2</sup>) or D-7 ( $A_{\text{Capacity}} = 1.47$  ft<sup>2</sup>). ∴ OK

At  $n_2$  and  $b_2$ :  $A_{\text{capacity}} = 1.81$  ft<sup>2</sup> from D-5, and  $A_{\text{capacity}} = 2.04$  ft<sup>2</sup> from D-7: ∴ OK

If  $A_{\text{Stability}} > A_{\text{Capacity}}$ , it will be necessary to select new trial sizes for width and flow depth (based on space and other considerations), recalculate  $A_{\text{Capacity}}$ , and repeat steps SC-10 and SC-11.

**SC-12.** Calculate depth of flow at the stability design flow rate condition using the quadratic equation solution:

$$y = \frac{-b \pm \sqrt{b^2 - 4Z(-A)}}{2Z}$$

For  $b = 5.13$ ,  $y = 0.075$  ft (positive root)

**SC-13.** Greater depth is 0.25-foot, which was the basis for the biofiltration capacity design. Add 0.05 feet freeboard to that depth.

Total channel depth = 0.75 ft

Top Width =  $b + 2yZ$

=  $5.13 + (2)(0.75)(3)$

= 9.63 ft

**SC-14.** Recalculate hydraulic radius and flow rate.

For  $b = 5.13$  ft,  $y = 0.75$  ft

$Z = 3$ ,  $s = 0.02$ ,  $n = 0.2$

$A = by + Zy^2 = 5.54$  ft<sup>2</sup>

$R = by + Zy^2 / \{b + 2y\sqrt{Z^2 + 1}\} = 0.56$  ft.

**SC-15.** Calculate Flow Capacity at Greatest Resistance.

$$Q = \frac{1.49AR^{0.67}s^{0.5}}{n} = 3.9 \text{ cfs}$$

$Q = 3.9$  cfs > 1.6 cfs ∴ OK

At  $n_2$  and  $b_2$ :  $Q = 3.7$  cfs ∴ OK

**Completion Step:**

**CO-1.** Assume 180 feet of swale length is available.

The final channel dimensions are:

Bottom width,  $b = 5.13$  feet

Channel depth = 0.75 feet

Top width =  $b + 2yZ = 9.63$  feet

**CO-2.** At swale length of 130 feet and  $n_2$ :

Bottom width,  $b_2 = 7.41$  feet

Channel depth = 0.75 feet

Top width =  $b_2 + 2yZ = 11.91$  feet

No check dams are needed for a 2% slope.

**Soil Criteria:**

- The following top soil mix at least 8-inch deep:
  - Sandy loam 60-90 %
  - Clay 0-10 %
  - Composted organic matter, 10-30 %  
(excluding animal waste, toxics)
- Use compost amended soil where practicable.
- Till to at least 8-inch depth.
- For longitudinal slopes of < 2 percent use more sand to obtain more infiltration.
- If groundwater contamination is a concern, seal the bed with clay or a geomembrane liner.

**Vegetation Criteria:**

- See Tables 9.4, 9.5 and 9.6 for recommended grasses, wetland plants, and groundcovers.
- Select fine, turf-forming, water-resistant grasses where vegetative growth and moisture will be adequate for growth.
- Irrigate if moisture is insufficient during dry weather season.
- Use sod with low clay content and where needed to initiate adequate vegetative growth. Preferably sod should be laid to a minimum of one-foot vertical depth above the swale bottom.
- Consider sun/shade conditions for adequate vegetative growth and avoid prolonged shading of any portion not planted with shade tolerant vegetation.
- Stabilize soil areas upslope of the biofilter to prevent erosion.
- Fertilizing a biofilter should be avoided if at all possible in any application where nutrient control is an objective. Test the soil for nitrogen, phosphorous, and potassium and consult with a landscape professional about the need for fertilizer in relation to soil nutrition and vegetation requirements. If use of a fertilizer cannot be avoided, use a slow-release fertilizer formulation in the least amount needed.

**Recommended grasses (see Tables 9.4 and 9.5)****Construction Criteria:**

The biofiltration swale should not be put into operation until areas of exposed soil in the contributing drainage catchment have been sufficiently stabilized. Deposition of eroded soils can impede the growth of grass in the swale and reduce swale treatment effectiveness. Thus, effective erosion and sediment control measures should remain in place until the swale vegetation is established (see Volume II for erosion and sediment control BMPs). Avoid compaction during construction. Grade biofilters to attain uniform longitudinal and lateral slopes.

**Maintenance Criteria:**

- Inspect biofilters at least once every 6 months, preferably during storm events, and also after storm events of > 0.5 inch rainfall/ 24 hours. Maintain adequate grass growth and eliminate bare spots.
- Mow grasses, if needed for good growth {typically maintain at 4 – 9 inches and not below design flow level (King County, 1998)}.
- Remove sediment as needed at head of the swale if grass growth is inhibited in greater than 10 percent of the swale, or if the sediment is blocking the distribution and entry of the water (King County, 1998).
- Remove leaves, litter, and oily materials, and re-seed or resod, and regrade, as needed. Clean curb cuts and level spreaders as needed.

Prevent scouring and soil erosion in the biofilter. If flow channeling occurs, regrade and reseed the biofilter, as necessary.

Maintain access to biofilter inlet, outlet, and to mowing (Figure 9.7).

- If a swale is equipped with underdrains, vehicular traffic on the swale bottom (other than grass mowing equipment) should be avoided to prevent damage to the drainpipes.

## **BMP T9.20 Wet Biofiltration Swale**

### ***Description:***

A *wet biofiltration swale* is a variation of a basic biofiltration swale for use where the longitudinal slope is slight, water tables are high, or continuous low base flow is likely to result in saturated soil conditions. Where saturation exceeds about 2 weeks, typical grasses will die. Thus, vegetation specifically adapted to saturated soil conditions is needed. Different vegetation in turn requires modification of several of the design parameters for the basic biofiltration swale.

### ***Performance Objectives:***

To remove low concentrations of pollutants such as TSS, heavy metals, nutrients, and petroleum hydrocarbons.

### ***Applications/Limitations:***

Wet biofiltration swales are applied where a basic biofiltration swale is desired but not allowed or advisable because one or more of the following conditions exist:

- The swale is on till soils and is downstream of a detention pond providing flow control.
- Saturated soil conditions are likely because of seeps or base flows on the site.
- Longitudinal slopes are slight (generally less than 2 percent).

### ***Design Criteria:***

Use the same design approach as for basic biofiltration swales except to add the following:

**Adjust for extended wet season flow.** If the swale will be downstream of a detention pond providing flow control, multiply the treatment area (bottom width times length) of the swale by 2, and readjust the swale length, if desired. Maintain a 5:1 length to width ratio.

**Intent:** An increase in the treatment area of swales following detention ponds is required because of the differences in vegetation established in a constant flow environment. Flows following detention are much more prolonged. These prolonged flows result in more stream-like conditions than are typical for other wet biofilter situations. Since vegetation growing in streams is often less dense, this increase in treatment area is needed to ensure that equivalent pollutant removal is achieved in extended flow situations.

**Swale Geometry:** Same as specified for basic biofiltration swales except for the following modifications:

**Criterion 1:** The bottom width may be increased to 25 feet maximum, but a length-to-width ratio of 5:1 must be provided. No longitudinal dividing berm is needed. *Note: The minimum swale length is still 100 feet.*

**Criterion 2:** If longitudinal slopes are greater than 2 percent, the wet swale must be stepped so that the slope within the stepped sections averages 2 percent. Steps may be made of retaining walls, log check dams, or short riprap sections. **No underdrain or low-flow drain is required.**

**High-Flow Bypass:** A high-flow bypass is required for flows greater than the water quality design flow to protect wetland vegetation from damage. Unlike grass, wetland vegetation will not quickly regain an upright attitude after being laid down by high flows. New growth, usually from the base of the plant, often taking several weeks, is required to regain its upright form. The bypass may be an open channel parallel to the wet biofiltration swale.

**Water Depth and Base Flow:** Same as for basic biofiltration swales except the design water depth shall be 4 inches for all wetland vegetation selections, and **no underdrains or low-flow drains are required.**

**Flow Velocity, Energy Dissipation, and Flow Spreading:** Same as for basic biofiltration swales except no flow spreader is needed.

**Access:** Same as for basic biofiltration swales except access is only required to the inflow and the outflow of the swale; access along the length of the swale is not required. Also, wheel strips may not be used for access in the swale.

**Intent:** An access road is not required along the length of a wet swale because of infrequent access needs. Frequent mowing or harvesting is not desirable. In addition, wetland plants are fairly resilient to sediment-induced changes in water depth, so the need for access should be infrequent.

**Soil Amendment:** Same as for basic biofiltration swales.

**Planting Requirements:** Same as for basic biofiltration swales except for the following modifications:

1. A list of acceptable plants and recommended spacing is shown in Table 9.6. In general, it is best to plant several species to increase the likelihood that at least some of the selected species will find growing conditions favorable.
2. A wetland seed mix may be applied by hydroseeding, but if coverage is poor, planting of rootstock or nursery stock is required. Poor coverage is considered to be more than 30 percent bare area through the upper 2/3 of the swale after four weeks.



**Recommended Design Features:** Same as for basic biofiltration swales.

**Construction Considerations:** Same as for basic biofiltration swales.

**Maintenance Considerations:** Same as for basic biofiltration swales except mowing of wetland vegetation is not required. However, harvesting of very dense vegetation may be desirable in the fall after plant die-back to prevent the sloughing of excess organic material into receiving waters. Many native *Juncus* species remain green throughout the winter; therefore, fall harvesting of *Juncus* species is not recommended.

## **BMP T9.30 Continuous Inflow Biofiltration Swale**

### ***Description:***

In situations where water enters a biofiltration swale continuously along the side slope rather than discretely at the head, a different design approach—the continuous inflow biofiltration swale—is needed. The basic swale design is modified by increasing swale length to achieve an equivalent average residence time.

### ***Applications:***

A continuous inflow biofiltration swale is to be **used when inflows are not concentrated**, such as locations along the shoulder of a road without curbs. This design may also be **used where frequent, small point flows enter a swale**, such as through curb inlet ports spaced at intervals along a road, or from a parking lot with frequent curb cuts. In general, no inlet port should carry more than about 10 percent of the flow.

A continuous inflow swale is not appropriate for a situation in which significant lateral flows enter a swale at some point downstream from the head of the swale. In this situation, the swale width and length must be recalculated from the point of confluence to the discharge point in order to provide adequate treatment for the increased flows.

### ***Design Criteria:***

Same as specified for **basic biofiltration swale** except for the following:

- The design flow for continuous inflow swales must include runoff from the pervious side slopes draining to the swale along the entire swale length.
- If only a single design flow is used, the flow rate at the outlet should be used. The goal is to achieve an average residence time through the swale of 22 minutes. Assuming an even distribution of inflow into the side of the swale double the hydraulic residence time to a minimum of 44 minutes.
- For continuous inflow biofiltration swales, interior side slopes above the WQ design treatment elevation shall be planted in grass. A typical lawn seed mix or the biofiltration seed mixes are acceptable. Landscape plants or groundcovers other than grass may not be used anywhere between the runoff inflow elevation and the bottom of the swale.

**Intent:** The use of grass on interior side slopes reduces the chance of soil erosion and transfer of pollutants from landscape areas to the biofiltration treatment area.

## BMP T9.40 Basic Filter Strip

### **Description:**

A basic filter strip is flat with no side slopes (Figure 9.8). Contaminated storm water is distributed as sheet flow across the inlet width of a biofilter strip.

### **Applications/Limitations:**

The basic filter strip is typically used on-line and adjacent and parallel to a paved area such as parking lots, driveways, and roadways.

### **Design Criteria for Filter strips:**

- Use the Design Criteria specified in Table 9.3
- Filter strips should only receive sheet flow.
- Use curb cuts  $\geq$  12-inch wide and 1-inch above the filter strip inlet.

Calculate the design flow depth using Manning's equation as follows:

$$Q = (1.49A R^{0.67} s^{0.5})/n$$

Substituting for AR:

$$Q = (1.49Ty^{1.67} s^{0.5})/n$$

Where:

$$Ty = A_{\text{rectangle, ft}}^2$$

$y \approx R_{\text{rectangle}}$ , design depth of flow, ft. (1 inch maximum)

Q = peak Water Quality design flow rate based on WWHM, ft<sup>3</sup>/sec  
(See Appendix I-B, Volume I)

n = Manning's roughness coefficient

s = Longitudinal slope of filter strip parallel to direction of flow

T = Width of filter strip perpendicular to the direction of flow, ft.

A = Filter strip inlet cross-sectional flow area (rectangular), ft<sup>2</sup>

R = hydraulic radius, ft.

Rearranging for y:

$$y = [2.5Qn/1.49Ts^{0.5}]^{0.6}$$

y must not exceed 1 inch

*Note: As in swale design an adjustment factor of 2.5 accounts for the differential between the WWHM Water Quality design flow rate and the SBUH design flow.*

Calculate the design flow velocity  $V$ , ft./sec., through the filter strip:

$$V = Q/Ty$$

$V$  must not exceed 0.5 ft./sec

Calculate required length, ft., of the filter strip at the minimum hydraulic residence time,  $t$ , of 22 minutes:

$$L = tV = 1320 V$$

## **BMP T9.50 Narrow Area Filter Strip**

### ***Description:***

This section describes a filter strip design<sup>1</sup> for impervious areas with flowpaths of 30 feet or less that can drain along their widest dimension to grassy areas.

### ***Applications/Limitations:***

A narrow area filter strip could be used at roadways with limited right-of-way, or for narrow parking strips, the narrow strip. If space is available to use the basic filter strip design, that design should be used in preference to the narrow filter strip.

The treatment objectives, applications and limitations, design criteria, materials specifications, and construction and maintenance requirements set forth in the basic filter strip design apply to narrow filter strip applications.

### ***Design Criteria:***

Design criteria for narrow area filter strips are the *same as specified for basic filter strips*. The sizing of a narrow area filter strip is based on the length of flowpath draining to the filter strip and the longitudinal slope of the filter strip itself (parallel to the flowpath).

*Step 1:* Determine the length of the flowpath from the upstream to the downstream edge of the impervious area draining sheet flow to the strip. Normally this is the same as the width of the paved area, but if the site is sloped, the flow path may be longer than the width of the impervious area.

*Step 2:* Calculate the longitudinal slope of the filter strip (along the direction of unconcentrated flow), averaged over the total width of the filter strip. The minimum sizing slope is 2 percent. If the slope is less than 2 percent, use 2 percent for sizing purposes. The maximum allowable filter strip slope is 20 percent. If the slope exceeds 20 percent, the filter strip must be stepped down the slope so that the treatment areas between drop sections do not have a longitudinal slope greater than 20 percent. Drop sections must be provided with erosion protection at the base and flow spreaders to re-spread flows. Vertical drops along the slope must not exceed 12 inches in height. If this is not possible, a different treatment facility must be selected.

*Step 3:* Select the appropriate filter strip length for the flowpath length and filter strip longitudinal slope (Steps 1 and 2 above) from the graph in Figure 9.9. The filter strip must be designed to provide this minimum length *L* along the entire stretch of pavement draining into it.

---

<sup>1</sup> This narrow area filter strip design method is included here because technical limitations exist in the basic design method which result in filter strips that are proportionately longer as the contributing drainage becomes narrower (a result that is counter-intuitive). Research by several parties is underway to evaluate filter strip design parameters. This research may lead to more stringent design requirements that would supersede the design criteria presented here.

*To use the graph:* Find the length of the flowpath on one of the curves (interpolate between curves as necessary). Move along the curve to the point where the design longitudinal slope of the filter strip (x-axis) is directly below. Read the filter strip length on the y-axis which corresponds to the intersection point.

Table 9.1 -- Sizing Criteria		
Design parameter	BMP T 9.10-Biofiltration swale	BMP T 9.40-Filter strip
Longitudinal Slope	0.015 - 0.025 <sup>1</sup>	0.01 - 0.15
Maximum velocity	1 ft / sec ( @ WQ design flow rate; for stability, 5ft/sec max. preferred (see also Table 9.3)	0.5 ft / sec
Maximum water depth <sup>2</sup>	2"- if mowed frequently; 4" if mowed infrequently	1-inch max.
Manning coefficient (22)	(0.2 – 0.3) <sup>3</sup> (0.24 if mowed infrequently)	0.35 (0.45 if mowed to maintain grass height ≤ 4")
Bed width (bottom)	(2 - 10 ft) <sup>4</sup>	---
Freeboard height	0.5 ft	---
Minimum hydraulic residence time at Water Quality Design Flow Rate	22 minutes (44 minutes for continuous inflow) (See Volume I, Appendix B)	22 minutes
Minimum length	100 ft	Sufficient to achieve hydraulic residence time in the filter strip
Maximum sideslope	3 H : 1 V 4H:1V preferred	Inlet edge ≥ 1" lower than contributing paved area
Max. tributary drainage flowpath	---	150 feet
Max. longitudinal slope of contributing area	---	0.05 (steeper than 0.05 need upslope flow spreading and energy dissipation)
Max. lateral slope of contributing area	---	0.02 (at the edge of the strip inlet)

1. For swales, if the slope is less than 1.5% install an underdrain using a perforated pipe, or equivalent. Amend the soil if necessary to allow effective percolation of water to the underdrain. Install the low-flow drain 6" deep in the soil. Slopes greater than 2.5% need check dams (riprap) at vertical drops of 12-15 inches. Underdrains can be made of 6 inch Schedule 40 PVC perforated pipe with 6" of drain gravel on the pipe. The gravel and pipe must be enclosed by geotextile fabric. (See Figures 9.2 and 9.3)
2. Below the design water depth install an erosion control blanket, at least 4" of topsoil, and the selected biofiltration mix. Above the water line use a straw mulch or sod.
3. This range of Manning's n can be used in the equation;  $b = Qn/1.49y^{(1.67)}s^{(0.5)} - Zy$  with wider bottom width b, and lower depth, y, at the same flow. This provides the designer with the option of varying the bottom width of the swale depending on space limitations. Designing at the higher n within this range at the same flow decreases the hydraulic design depth, thus placing the pollutants in closer contact with the vegetation and the soil.
4. For swale widths up to 16 feet the cross-section can be divided with a berm (concrete, plastic, compacted earthfill) using a flow spreader at the inlet (Figure 9.4)

<b>Coverage</b>	<b>Average Grass Height (inches)</b>	<b>Degree of Retardance</b>
<b>Good</b>	<2	E. Very Low
	2-6	D. Low
	6-10	C. Moderate
	11-24	B. High
	>30	A. Very High
<b>Fair</b>	<2	E. Very Low
	2-6	D. Low
	6-10	D. Low
	11-24	C. Moderate
	>30	B. High

See Chow (1959).. In addition, Chow recommended selection of retardance C for a grass-legume mixture 6-8 inches high and D for a mixture 4-5 inches high. No retardance recommendations have appeared for emergent wetland species. Therefore, judgment must be used. Since these species generally grow less densely than grasses, using a "fair" coverage would be a reasonable approach.

<b>Cover</b>	<b>Slope (percent)</b>	<b>Maximum Velocity (feet per second [m/s])</b>	
		<b>Erosion-Resistant Soils</b>	<b>Easily Eroded Soils</b>
Kentucky bluegrass Tall fescue	0-5	6 [1.8]	5 [1.5]
Kentucky bluegrass Ryegrasses Western wheat-grass	5-10	5 [1.5]	4 [1.2]
Grass-legume Mixture	0.5 5-10	5 [1.5] 4 [1.2]	4 [1.2] 3 [0.9]
Red fescue	0.5	3 [0.9]	2.5 [0.8]
Redtop	5-10	Not recommended	Not recommended

\*Adapted from Chow (1959), Livingston et al. (1984), and Goldman et al. (1986).



<b>Mix 1</b>		<b>Mix 2</b>	
75-80 percent	tall or meadow fescue	60-70 percent	tall fescue
10-15 percent	seaside/colonial bentgrass	10-15 percent	seaside/colonial bentgrass
5-10 percent	redtop	10-15 percent	meadow foxtail
		6-10 percent	alsike clover
		1-5 percent	marshfield big trefoil
		1-6 percent	redtop

Note: all percentages are by weight. \* based on Briargreen, Inc.

<b>Groundcovers</b>	
kinnikinnick*	<i>Arctostaphylos uva-ursi</i>
St. John's-wort	<i>Hypericum perforatum</i>
Epimedium	<i>Epimedium grandiflorum</i>
creeping forget-me-not	<i>Omphalodes verna</i>
--	<i>Euonymus lanceolata</i>
yellow-root	<i>Xanthorhiza simplissima</i>
--	<i>Genista</i>
white lawn clover	<i>Trifolium repens</i>
white sweet clover*	<i>Melilotus alba</i>
-----	<i>Rubus calycinoides</i>
strawberry*	<i>Fragaria chiloensis</i>
broadleaf lupine*	<i>Lupinus latifolius</i>
<b>Grasses (drought-tolerant, minimum mowing)</b>	
dwarf tall fescues	<i>Festuca</i> spp. (e.g., Many Mustang, Silverado)
hard fescue	<i>Festuca ovina duriuscula</i> (e.g., Reliant, Aurora)
tufted fescue	<i>Festuca amethystina</i>
buffalo grass	<i>Buchloe dactyloides</i>
red fescue*	<i>Festuca rubra</i>
tall fescue grass*	<i>Festuca arundinacea</i>
blue oatgrass	<i>Helictotrichon sempervirens</i>

<b>Table 9.6 Recommended plants for wet biofiltration swale</b>		
<b>Common Name</b>	<b>Scientific Name</b>	<b>Spacing (on center)</b>
Shortawn foxtail	<i>Alopecurus aequalis</i>	seed
Water foxtail	<i>Alopecurus geniculatus</i>	seed
Spike rush	<i>Eleocharis spp.</i>	4 inches
Slough sedge*	<i>Carex obnupta</i>	6 inches or seed
Sawbeak sedge	<i>Carex stipata</i>	6 inches
Sedge	<i>Carex spp.</i>	6 inches
Western mannagrass	<i>Glyceria occidentalis</i>	seed
Velvetgrass	<i>Holcus mollis</i>	seed
Slender rush	<i>Juncus tenuis</i>	6 inches
Watercress*	<i>Rorippa nasturtium-aquaticum</i>	12 inches
Water parsley*	<i>Oenanthe sarmentosa</i>	6 inches
Hardstem bulrush	<i>Scirpus acutus</i>	6 inches
Small-fruited bulrush	<i>Scirpus microcarpus</i>	12 inches

\* Good choices for swales with significant periods of flow, such as those downstream of a detention facility.

Note: Cattail (*Typha latifolia*) is not appropriate for most wet swales because of its very dense and clumping growth habit which prevents water from filtering through the clump.

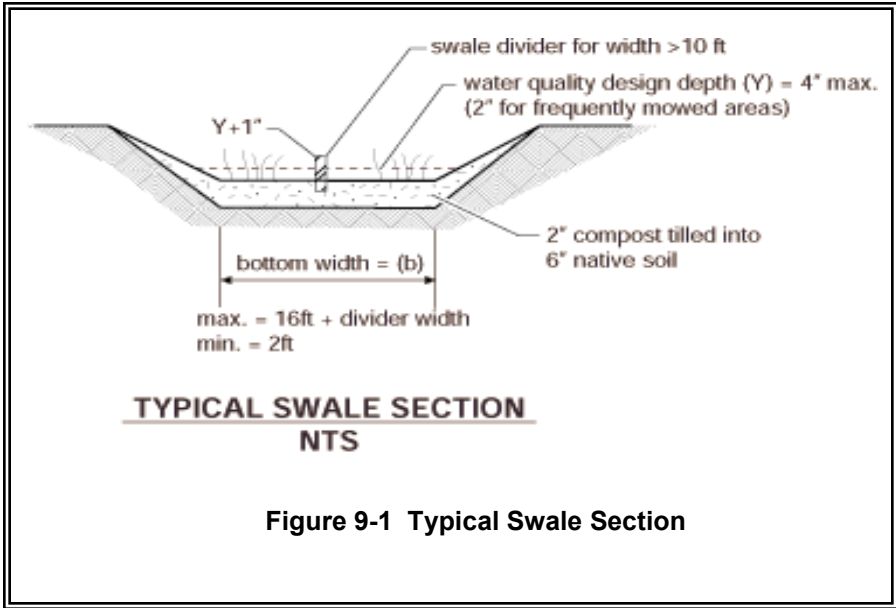


Figure 9-1 Typical Swale Section

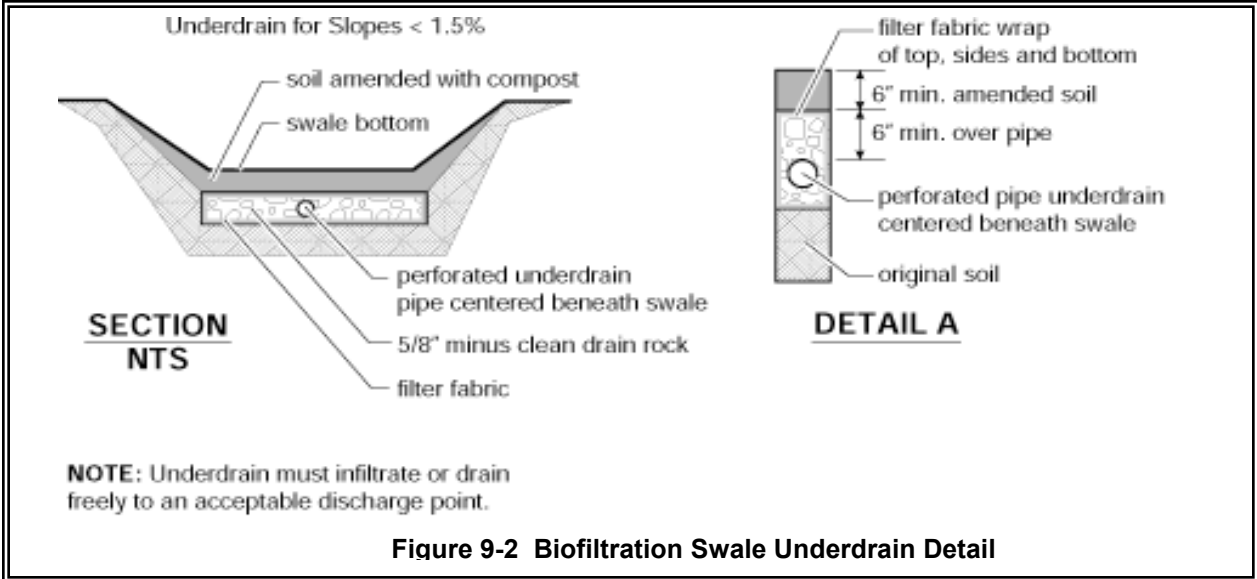


Figure 9-2 Biofiltration Swale Underdrain Detail

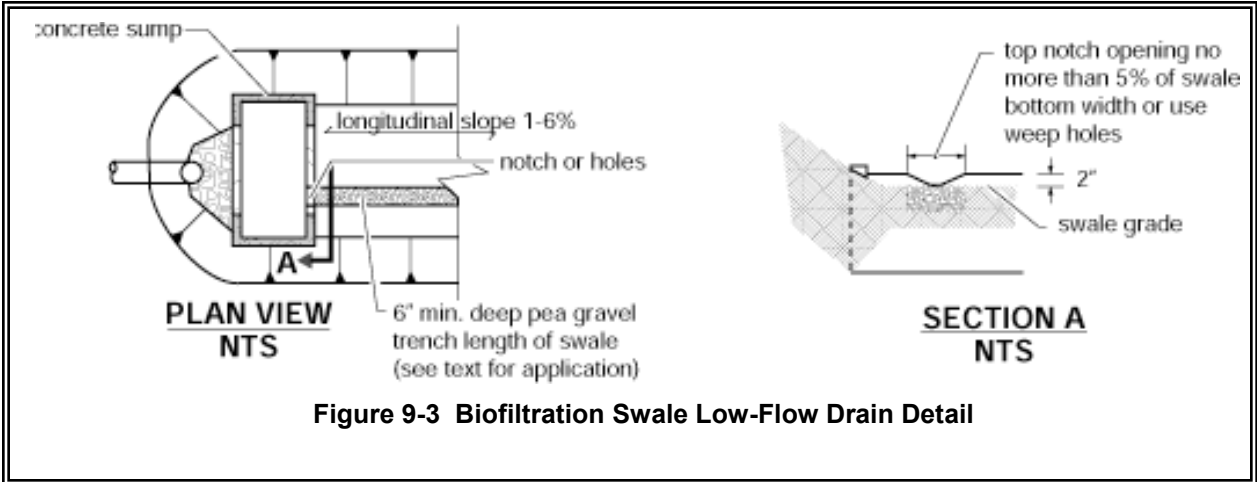
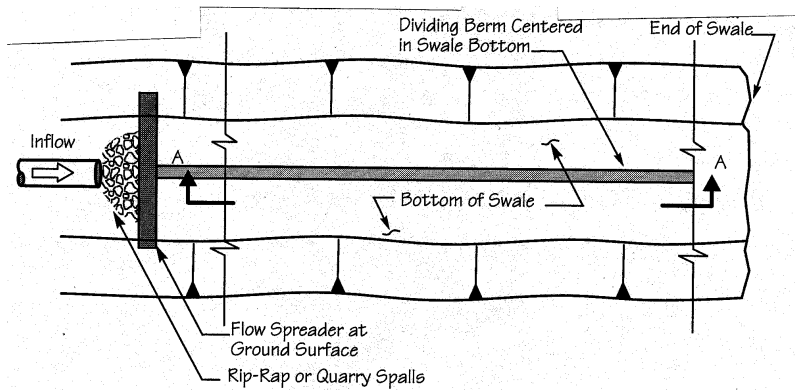
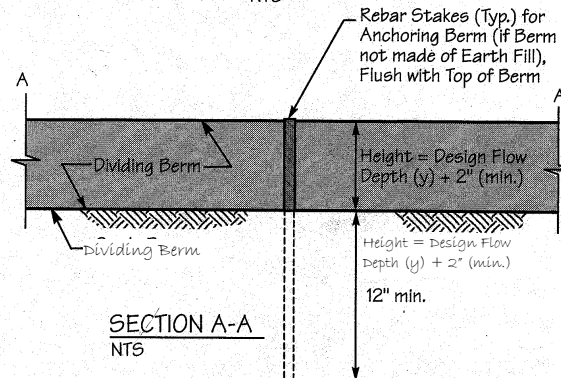


Figure 9-3 Biofiltration Swale Low-Flow Drain Detail



**PLAN VIEW**

NTS

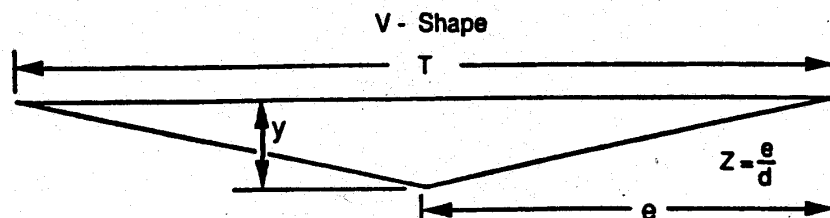


**Notes:**

1. Berm may be Made of Compacted Earthfill (seeded with grass), Timber, Concrete Plastic, or Similar Weather - Resistant Non - Erodible Material.
2. Rebar Stakes or Similar Berm Anchoring Materials Needed if Berm Made of Timber, Plastic, or Concrete Curbing - Stake Placement Required at Both Ends of Each Individual Member (at a minimum).

**Figure 9-4 Swale Dividing Berm**

### CHANNEL GEOMETRY

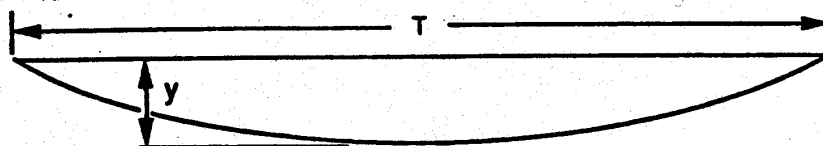


Cross-Sectional Area (A) =  $Zy^2$

Top Width (T) =  $2yZ$

Hydraulic Radius (R) =  $\frac{Zy}{2\sqrt{Z^2 + 1}}$

#### Parabolic Shape

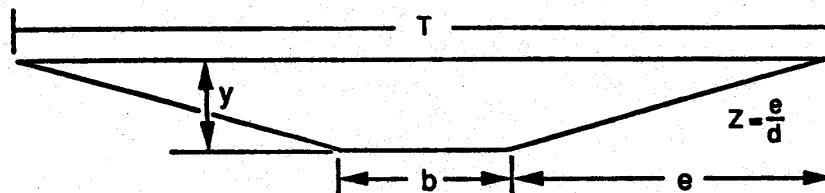


Cross-Sectional Area (A) =  $\frac{2}{3}Ty$

Top Width (T) =  $\frac{1.5A}{y}$

Hydraulic Radius (R) =  $\frac{T^2y}{1.5T^2 + 4y^2}$

#### Trapezoidal Shape



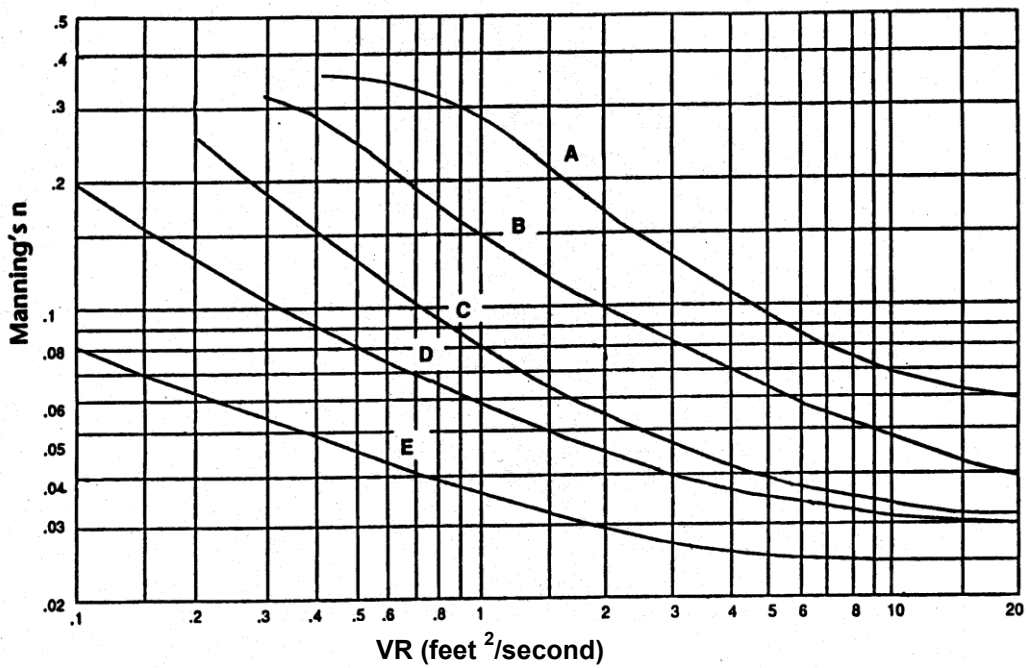
Cross-Sectional Area (A) =  $by + Zy^2$

Top Width (T) =  $b + 2yz$

Hydraulic Radius (R) =  $\frac{by + Zy^2}{b + 2y\sqrt{Z^2 + 1}}$

Figure 9-5 Geometric Formulas for Common Swale Shapes

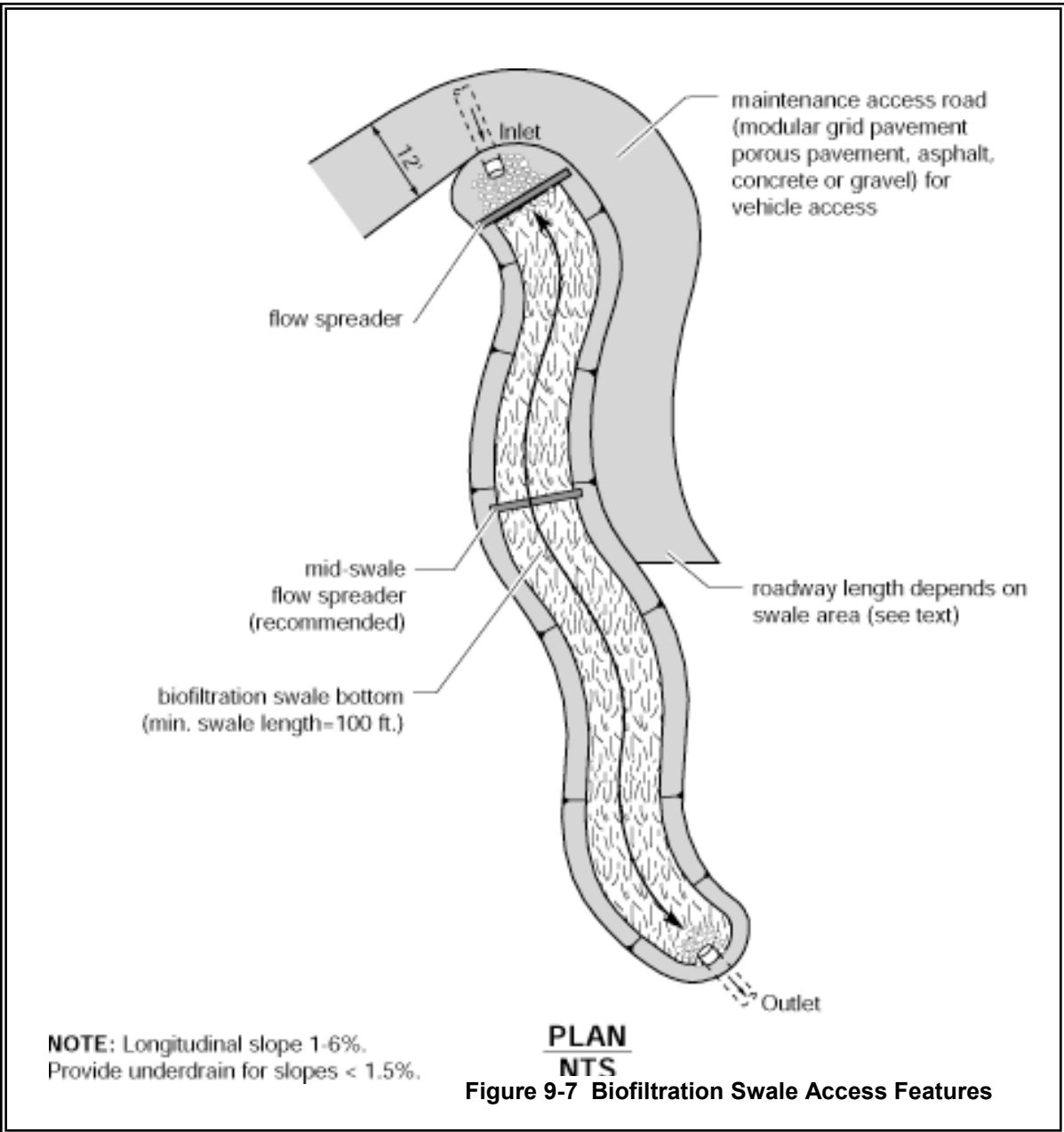
Source: Livingston, et al. 1984

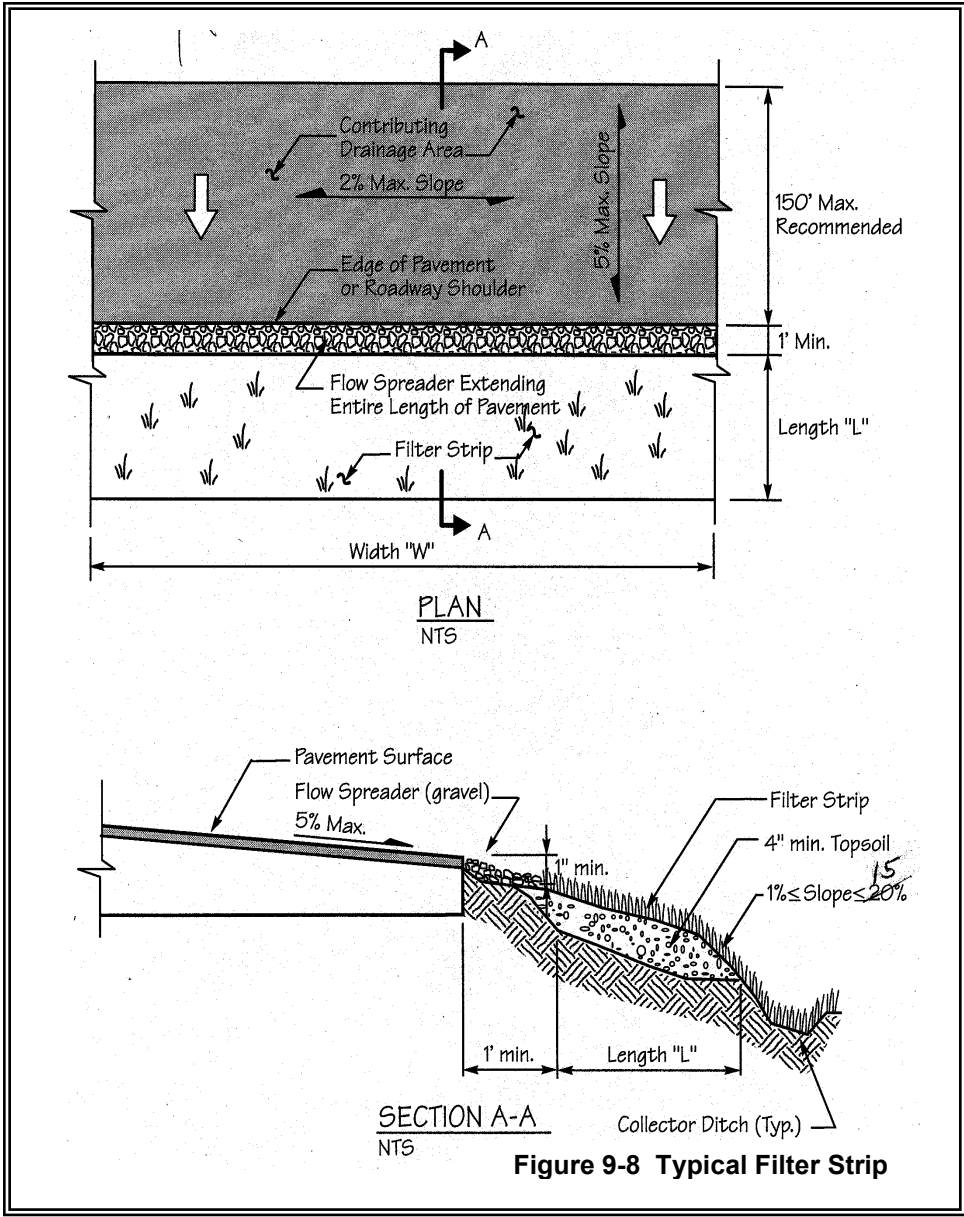


Note: VR is the product of velocity and hydraulic radius

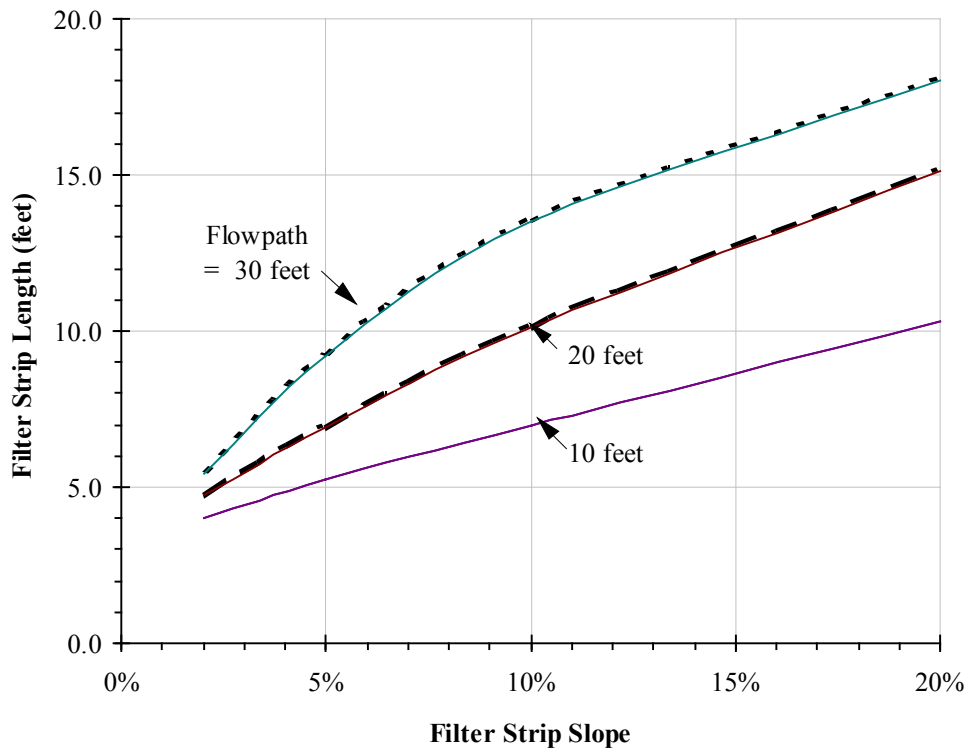
Figure 9-6 The Relationship of Manning's n with VR for Various Degrees of Flow Retardance (A-E)

Source: Livingston, et al, 1984









*Note: minimum allowable filter strip length is 4 feet*

**Figure 9-9 Filter Strip Lengths for Narrow Right-of-Way**

# Chapter 10 - Wetpool Facilities

---

*Note: Figures in Chapter 10 are from the King County Surface Water Design Manual.*

## 10.1 Purpose

This Chapter presents the methods, criteria, and details for analysis and design of wetponds, wetvaults, and storm water wetlands. These facilities have as a common element a permanent pool of water - the wetpool. Each of the wetpool facilities can be combined with a detention or flow control pond in a combined facility. Included are the following specific facility designs:

BMP T10.10 - Wetponds - Basic and Large

BMP T10.20 - Wetvaults

BMP T10.30 - Stormwater Wetlands

BMP T10.40 - Combined Detention and Wetpool Facilities

## 10.2 Application

The wetpool facility designs described for the four BMPs in this Chapter will achieve the performance objectives cited in Chapter 3 for specific treatment menus.

## 10.3 Best Management Practices (BMPs) for Wetpool Facilities

The four BMPs discussed below are currently recognized as effective treatment techniques using wetpool facilities. The specific BMPs that are selected should be coordinated with the Treatment Facility Menus discussed in Chapter 3.

## **BMP T10.10 Wetponds - Basic and Large**

### ***Purpose and Definition:***

A wetpond is a constructed storm water pond that retains a permanent pool of water ("wetpool") at least during the wet season. The volume of the wetpool is related to the effectiveness of the pond in settling particulate pollutants. As an option, a shallow marsh area can be created within the permanent pool volume to provide additional treatment for nutrient removal. Peak flow control can be provided in the "live storage" area above the permanent pool. Figures 10-1a and 10-1b illustrate a typical wet pond BMP.

The following design, construction, and operation and maintenance criteria cover two wetpond applications - the basic wetpond and the large wetpond. Large wetponds are designed for higher levels of pollutant removal.

### ***Applications and Limitations:***

A wetpond requires a larger area than a biofiltration swale or a sand filter, but it can be integrated to the contours of a site fairly easily. In till soils, the wetpond holds a permanent pool of water that provides an attractive aesthetic feature. In more porous soils, wetponds may still be used, but water seepage from unlined cells could result in a dry pond, particularly in the summer months. Lining the first cell with a low permeability liner is one way to deal with this situation. As long as the first cell retains a permanent pool of water, this situation will not reduce the pond's effectiveness but may be an aesthetic drawback.

Wetponds work best when the water already in the pond is moved out en masse by incoming flows, a phenomena called "plug flow." Because treatment works on this displacement principle, the wetpool storage of wetponds may be provided below the groundwater level without interfering unduly with treatment effectiveness. However, if combined with a detention function, the live storage must be above the seasonal high groundwater level.

Wetponds may be single-purpose facilities, providing only runoff treatment, or they may be combined with a detention pond to also provide flow control. If combined, the wetpond can often be stacked under the detention pond with little further loss of development area. See BMP T10.40 for a description of combined detention and wetpool facilities.

### ***Design Criteria:***

The primary design factor that determines a wetpond's treatment efficiency is the volume of the wetpool. The larger the wetpool volume, the greater the potential for pollutant removal. For a basic wetpond, the wetpool volume provided shall be equal to or greater than the total volume of runoff from the water quality design storm - the 6-month, 24-hour storm event. A large wetpond requires a wetpool volume at least 1.5 times larger than the total volume of runoff from the 6-month, 24-hour storm event.

Also important are the avoidance of short-circuiting and the promotion of plug flow. **Plug flow** describes the hypothetical condition of storm water moving through the pond as a unit, displacing the "old" water in the pond with incoming flows. To prevent short-circuiting, water is forced to flow, to the extent practical, to all potentially available flow routes, avoiding "dead zones" and maximizing the time water stays in the pond during the active part of a storm.

Design features that encourage plug flow and avoid dead zones are:

- Dissipating energy at the inlet.
- Providing a large length-to-width ratio.
- Providing a broad surface for water exchange using a berm designed as a broad-crested weir to divide the wetpond into two cells rather than a constricted area such as a pipe.
- Maximizing the flowpath between inlet and outlet, including the vertical path, also enhances treatment by increasing residence time.

### Sizing Procedure

Procedures for determining a wetpond's dimensions and volume are outlined below.

*Step 1:* Identify required wetpool volume using the SCS (now known as NRCS) curve number equations presented in Volume III, Chapter 2, Section 2.3.2. A basic wetpond requires a volume equal to or greater than the total volume of runoff from the 6-month, 24-hour storm event. A large wetpond requires a volume at least 1.5 times the total volume of runoff from the 6-month, 24-hour storm event.

*Step 2:* Determine wetpool dimensions. Determine the wetpool dimensions satisfying the design criteria outlined below and illustrated in Figures 10.1a and 10.1b. A simple way to check the volume of each wetpool cell is to use the following equation:

$$V = \frac{h(A_1 + A_2)}{2}$$

where:

$V$	=	wetpool volume (cf)
$h$	=	wetpool average depth (ft)
$A_1$	=	water quality design surface area of wetpool (sf)
$A_2$	=	bottom area of wetpool (sf)

*Step 3:* Design pond outlet pipe and determine primary overflow water surface. The pond outlet pipe shall be placed on a reverse grade from the pond's wetpool to the outlet structure. Use the following procedure to design the pond outlet pipe and determine the primary overflow water surface elevation:

- a) Use the nomographs in Figures 10.2 and 10.3 to select a trial size for the pond outlet pipe sufficient to pass the WQ design flow  $Q_{wq}$  (see Section 4.1.1 for a discussion on the WQ design flow).
- b) Use Figure 10.4 to determine the critical depth  $d_c$  at the outflow end of the pipe for  $Q_{wq}$ .

- c) Use Figure 10.5 to determine the flow area  $A_c$  at critical depth.
- d) Calculate the flow velocity at critical depth using continuity equation ( $V_c = Q_{wq} / A_c$ ).
- e) Calculate the velocity head  $V_H$  ( $V_H = V_c^2 / 2g$ , where  $g$  is the gravitational constant, 32.2 feet per second).
- f) Determine the primary overflow water surface elevation by adding the velocity head and critical depth to the invert elevation at the outflow end of the pond outlet pipe (i.e., overflow water surface elevation = outflow invert +  $d_c$  +  $V_H$ ).
- g) Adjust outlet pipe diameter as needed and repeat Steps (a) through (e).

**Step 4:** Determine wetpond dimensions.

General wetpond design criteria and concepts are shown in Figure 10.1a and 10.1b.

### **Wetpool Geometry**

- The wetpool shall be divided into two cells separated by a baffle or berm. The first cell shall contain between 25 to 35 percent of the total wetpool volume. The baffle or berm volume shall not count as part of the total wetpool volume. The term baffle means a vertical divider placed across the entire width of the pond, stopping short of the bottom. A berm is a vertical divider typically built up from the bottom, or if in a vault, connects all the way to the bottom.

**Intent:** The full-length berm or baffle promotes plug flow and enhances quiescence and laminar flow through as much of the entire water volume as possible.

- Sediment storage shall be provided in the first cell. The sediment storage shall have a minimum depth of 1-foot. A fixed sediment depth monitor should be installed in the first cell to gauge sediment accumulation unless an alternative gauging method is proposed.
- The minimum depth of the first cell shall be 4 feet, exclusive of sediment storage requirements. The depth of the first cell may be greater than the depth of the second cell.
- The maximum depth of each cell shall not exceed 8 feet (exclusive of sediment storage in the first cell). Pool depths of 3 feet or shallower (second cell) shall be planted with emergent wetland vegetation (see Planting requirements).
- Inlets and outlets shall be placed to maximize the flowpath through the facility. The ratio of flowpath length to width from the inlet to the outlet shall be at least 3:1. The **flowpath length** is defined as the distance from the inlet to the outlet, as measured at mid-depth. The **width** at mid-depth can be found as follows: width = (average top width + average bottom width)/2.
- Wetponds with wetpool volumes less than or equal to 4,000 cubic feet may be single celled (i.e., no baffle or berm is required). However, it

is especially important in this case that the flow path length be maximized. The ratio of flow path length to width shall be at least 4:1 in single celled wetponds, but should preferably be 5:1.

- All inlets shall enter the first cell. If there are multiple inlets, the length-to-width ratio shall be based on the average flowpath length for all inlets.
- The first cell may be lined in accordance with the liner requirements contained in Section 4.4.

### **Berms, Baffles, and Slopes**

- A berm or baffle shall extend across the full width of the wetpool, and tie into the wetpond side slopes. If the berm embankments are greater than 4 feet in height, the berm must be constructed by excavating a key with dimensions equal to 50 percent of the embankment cross-sectional height and width. This requirement may be waived if recommended by a geotechnical engineer for specific site conditions. The geotechnical analysis shall address situations in which one of the two cells is empty while the other remains full of water.
- The top of the berm may extend to the WQ design water surface or be 1-foot below the WQ design water surface. If at the WQ design water surface, berm side slopes should be 3H:1V. Berm side slopes may be steeper (up to 2:1) if the berm is submerged 1-foot.

**Intent:** Submerging the berm is intended to enhance safety by discouraging pedestrian access when side slopes are steeper than 3H:1V. An alternative to the submerged berm design is the use of barrier planting to prevent easy access to the divider berm in an unfenced wetpond.

- If good vegetation cover is not established on the berm, erosion control measures should be used to prevent erosion of the berm back-slope when the pond is initially filled.
- The interior berm or baffle may be a retaining wall provided that the design is prepared and stamped by a licensed civil engineer. If a baffle or retaining wall is used, it should be submerged one foot below the design water surface to discourage access by pedestrians.
- Criteria for wetpond side slopes are included in Section 4.3.

### **Embankments**

Embankments that impound water must comply with the Washington State Dam Safety Regulations (Chapter 173-175 WAC). If the impoundment has a storage capacity (including both water and sediment storage volumes) greater than 10 acre-feet (435,600 cubic feet or 3.26 million gallons) above natural ground level, then dam safety design and review are required by the Department of Ecology (see Volume III, Section 3.3.1).

## Inlet and Outlet

See Figure 10.1a and 10.1b for details on the following requirements:

- The inlet to the wetpond shall be submerged with the inlet pipe invert a minimum of two feet from the pond bottom (not including sediment storage). The top of the inlet pipe should be submerged at least 1-foot, if possible.

**Intent:** The inlet is submerged to dissipate energy of the incoming flow. The distance from the bottom is set to minimize resuspension of settled sediments. Alternative inlet designs that accomplish these objectives are acceptable.

- An outlet structure shall be provided. Either a Type 2 catch basin with a grated opening (jail house window) or a manhole with a cone grate (birdcage) may be used (see Volume III, Figure 3.11 for an illustration). No sump is required in the outlet structure for wetponds not providing detention storage. The outlet structure receives flow from the pond outlet pipe. The grate or birdcage openings provide an overflow route should the pond outlet pipe become clogged. The overflow criteria provided below specifies the sizing and position of the grate opening.
- The pond outlet pipe (as opposed to the manhole or type 2 catch basin outlet pipe) shall be back-sloped or have a turn-down elbow, and extend 1 foot below the WQ design water surface. Note: A floating outlet, set to draw water from 1-foot below the water surface, is also acceptable if vandalism concerns are adequately addressed.

**Intent:** The inverted outlet pipe provides for trapping of oils and floatables in the wetpond.

- The pond outlet pipe shall be sized, at a minimum, to pass the WQ design flow. Note: The highest invert of the outlet pipe sets the WQ design water surface elevation.
- The overflow criteria for single-purpose (treatment only, not combined with flow control) wetponds are as follows:
  - a) The requirement for primary overflow is satisfied by either the grated inlet to the outlet structure or by a birdcage above the pond outlet structure.
  - b) The bottom of the grate opening in the outlet structure shall be set at or above the height needed to pass the WQ design flow through the pond outlet pipe. *Note: The grate invert elevation sets the overflow water surface elevation.*
  - c) In on-line ponds, the grated opening should be sized to pass the 100-year design flow. The capacity of the outlet system should be sized to pass the peak flow for the conveyance requirements.
- An emergency spillway shall be provided and designed according to the requirements for detention ponds (see Volume III, Section 3.3.1).
- The City may require a bypass/shutoff valve to enable the pond to be taken offline for maintenance purposes.

- A gravity drain for maintenance is recommended if grade allows.  
**Intent:** It is anticipated that sediment removal will only be needed for the first cell in the majority of cases. The gravity drain is intended to allow water from the first cell to be drained to the second cell when the first cell is pumped dry for cleaning.
- The drain invert shall be at least 6 inches below the top elevation of the dividing berm or baffle. Deeper drains are encouraged where feasible, but must be no deeper than 18 inches above the pond bottom.  
**Intent:** To prevent highly sediment-laden water from escaping the pond when drained for maintenance.
- The drain shall be at least 8 inches (minimum) diameter and shall be controlled by a valve. Use of a shear gate is allowed only at the inlet end of a pipe located within an approved structure.  
**Intent:** Shear gates often leak if water pressure pushes on the side of the gate opposite the seal. The gate should be situated so that water pressure pushes toward the seal.
- Operational access to the valve shall be provided to the finished ground surface.
- The valve location shall be accessible and well marked with 1-foot of paving placed around the box. It must also be protected from damage and unauthorized operation.
- A valve box is allowed to a maximum depth of 5 feet without an access manhole. If over 5 feet deep, an access manhole or vault is required.
- All metal parts shall be corrosion-resistant. Galvanized materials should not be used unless unavoidable.  
**Intent:** Galvanized metal contributes zinc to storm water, sometimes in very high concentrations.

### **Access and Setbacks**

See Section 3.2.1 of Volume III.

- Access and maintenance roads shall extend to both the wetpond inlet and outlet structures. An access ramp (7H minimum:1V) shall be provided to the bottom of the first cell unless all portions of the cell can be reached and sediment loaded from the top of the pond.
- If the dividing berm is also used for access, it should be built to sustain loads of up to 80,000 pounds.

### **Planting Requirements**

Planting requirements for detention ponds also apply to wetponds.

- Large wetponds intended for phosphorus control should not be planted within the cells, as the plants will release phosphorus in the



winter when they die off. Phosphorus uptake is achieved in large wetponds through algae growth.

- If the second cell of a basic wetpond is 3 feet or shallower, the bottom area shall be planted with emergent wetland vegetation. See Table 10.1 for recommended emergent wetland plant species for wetponds.

**Intent:** Planting of shallow pond areas helps to stabilize settled sediment and prevent resuspension.

Note: The recommendations in Table 10.1 are for western Washington only. Local knowledge should be used to adapt this information if used in other areas.

- Cattails (*Typha latifolia*) are not recommended because they tend to crowd out other species and will typically establish themselves anyway.
- If the wetpond discharges to a phosphorus-sensitive lake or wetland, shrubs that form a dense cover should be planted on slopes above the WQ design water surface on at least three sides. For banks that are berms, no planting is allowed if the berm is regulated by dam safety requirements. The purpose of planting is to discourage waterfowl use of the pond and to provide shading. Some suitable trees and shrubs include vine maple (*Acer circinatum*), wild cherry (*Prunus emarginata*), red osier dogwood (*Cornus stolonifera*), California myrtle (*Myrica californica*), Indian plum (*Oemleria cerasiformis*), and Pacific yew (*Taxus brevifolia*) as well as numerous ornamental species.

### **Recommended Design Features**

The following design features should be incorporated into the wetpond design where site conditions allow:

- The method of construction of soil/landscape systems can cause natural selection of specific plant species. Consult a soil restoration or wetland soil scientist for site-specific recommendations. The soil formulation will impact the plant species that will flourish or suffer on the site, and the formulation should be such that it encourages desired species and discourages undesired species.
- For wetpool depths in excess of 6 feet, it is recommended that some form of recirculation be provided in the summer, such as a fountain or aerator, to prevent stagnation and low dissolved oxygen conditions.
- A flow length-to-width ratio greater than the 3:1 minimum is desirable. If the ratio is 4:1 or greater, then the dividing berm is not required, and the pond may consist of one cell rather than two.
- A tear-drop shape, with the inlet at the narrow end, rather than a rectangular pond is preferred since it minimizes dead zones caused by corners.
- A small amount of base flow is desirable to maintain circulation and reduce the potential for low oxygen conditions during late summer.

- Evergreen or columnar deciduous trees along the west and south sides of ponds are recommended to reduce thermal heating, except that no trees or shrubs may be planted on berms meeting the criteria of dams regulated for safety. In addition to shade, trees and shrubs also discourage waterfowl use and the attendant phosphorus enrichment problems they cause. Trees should be set back so that the branches will not extend over the pond.

**Intent:** Evergreen trees or shrubs are preferred to avoid problems associated with leaf drop. Columnar deciduous trees (e.g., hornbeam, Lombardy poplar, etc.) typically have fewer leaves than other deciduous trees.

- The number of inlets to the facility should be limited; ideally there should be only one inlet. The flowpath length should be maximized from inlet to outlet for all inlets to the facility.
- The access and maintenance road could be extended along the full length of the wetpond and could double as playcourts or picnic areas. Placing finely ground bark or other natural material over the road surface would render it more pedestrian friendly.
- The following design features should be incorporated to enhance aesthetics where possible:
  - Provide pedestrian access to shallow pool areas enhanced with emergent wetland vegetation. This allows the pond to be more accessible without incurring safety risks.
  - Provide side slopes that are sufficiently gentle to avoid the need for fencing (3:1 or flatter).
  - Create flat areas overlooking or adjoining the pond for picnic tables or seating that can be used by residents. Walking or jogging trails around the pond are easily integrated into site design.
  - Include fountains or integrated waterfall features for privately maintained facilities.
  - Provide visual enhancement with clusters of trees and shrubs. On most pond sites, it is important to amend the soil before planting since ponds are typically placed well below the native soil horizon in very poor soils. Make sure dam safety restrictions against planting do not apply.
  - Orient the pond length along the direction of prevailing summer winds (typically west or southwest) to enhance wind mixing.

**Construction Criteria:**

- Sediment that has accumulated in the pond must be removed after construction in the drainage area of the pond is complete (unless used for a liner - see below).
- Sediment that has accumulated in the pond at the end of construction may be used as a liner in excessively drained soils if the sediment meets the criteria for low permeability or treatment liners in keeping

with guidance given in Chapter 4. Sediment used for a soil liner must be graded to provide uniform coverage and thickness.

***Operation and Maintenance:***

- Maintenance is of primary importance if wetponds are to continue to function as originally designed. All private drainage systems serving multiple lots shall require a signed Covenant and Easement agreement with the City. The agreement shall designate the systems to be maintained and the parties responsible for maintenance. Contact the City to determine the applicability of this requirement to a project. A specific maintenance plan shall be formulated outlining the schedule and scope of maintenance operations.
- The pond may be inspected by the City. The maintenance standards contained in Section 4.6 are measures for determining if maintenance actions are required as identified through the annual inspection.
- Site vegetation should be trimmed as necessary to keep the pond free of leaves and to maintain the aesthetic appearance of the site. Slope areas that have become bare should be revegetated and eroded areas should be regraded prior to being revegetated.
- Sediment should be removed when the 1-foot sediment zone is full plus 6 inches. Sediments should be tested for toxicants in compliance with current disposal requirements. Sediments must be disposed in accordance with current local health department requirements and the Minimum Functional Standards for Solid Waste Handling. See Volume IV, Appendix IV-G Recommendations for Management of Street Waste for additional guidance.
- Any standing water removed during the maintenance operation must be properly disposed of. The preferred disposal option is discharge to a sanitary sewer at an approved location. Other disposal options include discharge back into the wetpool facility or the storm sewer system if certain conditions are met. See Volume IV, Appendix IV-G for additional guidance.

## **BMP T10.20 Wetvaults**

### ***Purpose and Definition:***

A wetvault is an underground structure similar in appearance to a detention vault, except that a wetvault has a permanent pool of water (wetpool) which dissipates energy and improves the settling of particulate pollutants (see the wetvault details in Figure 10.6). Being underground, the wetvault lacks the biological pollutant removal mechanisms, such as algae uptake, present in surface wetponds.

### ***Applications and Limitations:***

A wetvault may be used for commercial, industrial, or roadway projects if there are space limitations precluding the use of other treatment BMPs. The use of wetvaults for residential development is highly discouraged. Combined detention and wetvaults are allowed; see BMP T10.40.

A wetvault is believed to be ineffective in removing dissolved pollutants such as soluble phosphorus or metals such as copper. There is also concern that oxygen levels will decline, especially in warm summer months, because of limited contact with air and wind. However, the extent to which this potential problem occurs has not been documented.

Below-ground structures like wetvaults are relatively difficult and expensive to maintain. The need for maintenance is often not seen and as a result routine maintenance does not occur.

If oil control is required for a project, a wetvault may be combined with an API oil/water separator.

### ***Design Criteria:***

#### **Sizing Procedure**

As with wetponds, the primary design factor that determines the removal efficiency of a wetvault is the volume of the wetpool. The larger the volume, the higher the potential for pollutant removal. Performance is also improved by avoiding dead zones (like corners) where little exchange occurs, using large length-to-width ratios, dissipating energy at the inlet, and ensuring that flow rates are uniform to the extent possible and not increased between cells.

The sizing procedure for a wetvault is identical to the sizing procedure for a wetpond. The wetpool volume for the wetvault shall be equal to or greater than the total volume of runoff from the 6-month, 24-hour storm event.

Typical design details and concepts for the wetvault are shown in Figure 10.6.

#### **Wetpool Geometry**

Same as specified for wetponds (see BMP T10.10) except for the following two modifications:

- The sediment storage in the first cell shall be an average of 1-foot. Because of the v-shaped bottom, the depth of sediment storage needed above the bottom of the side wall is roughly proportional to vault width according to the schedule below:

<u>Vault Width</u>	<u>Sediment Depth (from bottom of side wall)</u>
15'	10"
20'	9"
40'	6"
60'	4"

- The second cell shall be a minimum of 3 feet deep since planting cannot be used to prevent resuspension of sediment in shallow water as it can in open ponds.

### **Vault Structure**

- The vault shall be separated into two cells by a wall or a removable baffle. If a wall is used, a 5-foot by 10-foot removable maintenance access must be provided for both cells. If a removable baffle is used, the following criteria apply:
  - 1) The baffle shall extend from a minimum of 1-foot above the WQ design water surface to a minimum of 1-foot below the invert elevation of the inlet pipe.
  - 2) The lowest point of the baffle shall be a minimum of 2 feet from the bottom of the vault, and greater if feasible.
- If the vault is less than 2,000 cubic feet (inside dimensions), or if the length-to-width ratio of the vault pool is 5:1 or greater, the baffle or wall may be omitted and the vault may be one-celled.
- The two cells of a wetvault should not be divided into additional subcells by internal walls. If internal structural support is needed, it is preferred that post and pier construction be used to support the vault lid rather than walls. Any walls used within cells must be positioned so as to lengthen, rather than divide, the flowpath.
 

**Intent:** Treatment effectiveness in wetpool facilities is related to the extent to which plug flow is achieved and short-circuiting and dead zones are avoided. Structural walls placed within the cells can interfere with plug flow and create significant dead zones, reducing treatment effectiveness.
- The bottom of the first cell shall be sloped toward the access opening. Slope should be between 0.5 percent (minimum) and 2 percent (maximum). The second cell may be level (longitudinally) sloped toward the outlet, with a high point between the first and second cells. The intent of sloping the bottom is direct the sediment accumulation to the closest access point for maintenance purposes. Sloping the second cell towards the access opening for the first cell is also acceptable.

- The vault bottom shall slope laterally a minimum of 5 percent from each side towards the center, forming a broad "v" to facilitate sediment removal. Note: More than one "v" may be used to minimize vault depth.

*Exception:* The City may allow the vault bottom to be flat if removable panels are provided over the entire vault. Removable panels should be at grade, have stainless steel lifting eyes, and weigh no more than 5 tons per panel.

- The highest point of a vault bottom must be at least 6 inches below the outlet elevation to provide for sediment storage over the entire bottom.
- Provision for passage of flows should the outlet plug shall be provided.
- Wetvaults may be constructed using arch culvert sections provided the top area at the WQ design water surface is, at a minimum, equal to that of a vault with vertical walls designed with an average depth of 6 feet.

**Intent:** To prevent decreasing the surface area available for oxygen exchange.

- Wetvaults shall conform with the "Materials" and "Structural Stability" criteria specified for detention vaults in Volume III, Chapter 3.
- Where pipes enter and leave the vault below the WQ design water surface, they shall be sealed using a non-porous, non-shrinking grout.

#### **Inlet and Outlet**

- The inlet to the wetvault shall be submerged with the inlet pipe invert a minimum of 3 feet from the vault bottom. The top of the inlet pipe should be submerged at least 1-foot, if possible.

**Intent:** The submerged inlet is to dissipate energy of the incoming flow. The distance from the bottom is to minimize resuspension of settled sediments. Alternative inlet designs that accomplish these objectives are acceptable.

- Unless designed as an off-line facility, the capacity of the outlet pipe and available head above the outlet pipe should be designed to convey the 100-year design flow for developed site conditions without overtopping the vault. The available head above the outlet pipe must be a minimum of 6 inches.
- The outlet pipe shall be back-sloped or have tee section, the lower arm of which should extend 1 foot below the WQ design water surface to provide for trapping of oils and floatables in the vault.
- The City may require a bypass/shutoff valve to enable the vault to be taken offline for maintenance.

### **Access Requirements**

Same as for detention vaults (see Volume III, Section 3.3 ), except for the following additional requirement for wetvaults:

- A minimum of 50 square feet of grate should be provided over the second cell. For vaults in which the surface area of the second cell is greater than 1,250 square feet, 4 percent of the top should be grated. This requirement may be met by one grate or by many smaller grates distributed over the second cell area. Note: A grated access door can be used to meet this requirement.

**Intent:** The grate allows air contact with the wetpool in order to minimize stagnant conditions which can result in oxygen depletion, especially in warm weather.

### **Access Roads, Right of Way, and Setbacks**

Same as for detention vaults (see Volume III, Section 3.3).

### **Recommended Design Features**

The following design features should be incorporated into wetvaults where feasible, but they are not specifically required:

- The floor of the second cell should slope toward the outlet for ease of cleaning.
- The inlet and outlet should be at opposing corners of the vault to increase the flowpath.
- A flow length-to-width ratio greater than 3:1 minimum is desirable.
- Lockable grates instead of solid manhole covers are recommended to increase air contact with the wetpool.
- Galvanized materials shall not be used unless unavoidable.
- The number of inlets to the wetvault should be limited, and the flowpath length should be maximized from inlet to outlet for all inlets to the vault.

### **Construction Criteria**

Sediment that has accumulated in the vault must be removed after construction in the drainage area is complete. If no more than 12 inches of sediment have accumulated after the infrastructure is built, cleaning may be left until after building construction is complete. In general, sediment accumulation from stabilized drainage areas is not expected to exceed an average of 4 inches per year in the first cell. If sediment accumulation is greater than this amount, it will be assumed to be from construction unless it can be shown otherwise.

### ***Operation and Maintenance***

- Accumulated sediment and stagnant conditions may cause noxious gases to form and accumulate in the vault. Vault maintenance procedures must meet OSHA confined space entry requirements, which includes clearly marking entrances to confined space areas. This may be accomplished by hanging a removable sign in the access riser(s), just under the access lid.
- Facilities may be inspected by the City. The maintenance standards contained in Section 4.6 of this volume are measures for determining if maintenance actions are required as identified through the inspection.
- Sediment should be removed when the 1-foot sediment zone is full plus 6 inches. Sediments should be tested for toxicants in compliance with current disposal requirements. Sediments must be disposed in accordance with current local health department requirements and the Minimum Functional Standards for Solid Waste Handling. See Volume IV, Appendix IV-G Recommendations for Management of Street Waste for additional guidance.
- Any standing water removed during the maintenance operation must be properly disposed of. The preferred disposal option is discharge to a sanitary sewer at an approved location. Other disposal options include discharge back into the wetpool facility or the storm sewer system if certain conditions are met. See Volume IV, Appendix IV-G for additional guidance.

### ***Modifications for Combining with a Baffle Oil/Water Separator***

If the project site is a high-use site and a wetvault is proposed, the vault may be combined with a baffle oil/water separator to meet the runoff treatment requirements with one facility rather than two. Structural modifications and added design criteria are given below. However, the maintenance requirements for baffle oil/water separators must be adhered to, in addition to those for a wetvault. This will result in more frequent inspection and cleaning than for a wetvault used only for TSS removal. See Chapter 11 for information on maintenance of baffle oil/water separators.

1. The sizing procedures for the baffle oil/water separator (Chapter 11) should be run as a check to ensure the vault is large enough. If the oil/water separator sizing procedures result in a larger vault size, increase the wetvault size to match.
2. An oil retaining baffle shall be provided in the second cell near the vault outlet. The baffle should not contain a high-flow overflow, or else the retained oil will be washed out of the vault during large storms.
3. The vault shall have a minimum length-to-width ratio of 5:1.



4. The vault shall have a design water depth-to-width ratio of between 1:3 to 1:2.
5. The vault shall be watertight and shall be coated to protect from corrosion.
6. Separator vaults shall have a shutoff mechanism on the outlet pipe to prevent oil discharges during maintenance and to provide emergency shut-off capability in case of a spill. A valve box and riser shall also be provided.
7. Wetvaults used as oil/water separators must be off-line and must bypass flows greater than the WQ design flow.

**Intent:** This design minimizes the entrainment and/or emulsification of previously captured oil during very high flow events.

## **BMP T10.30 Stormwater Treatment Wetlands**

### ***Purpose and Definition***

In land development situations, wetlands are usually constructed for two main reasons: to replace or mitigate impacts when natural wetlands are filled or impacted by development (mitigation wetlands), and to treat storm water runoff (storm water treatment wetlands). Storm water treatment wetlands are shallow man-made ponds that are designed to treat storm water through the biological processes associated with emergent aquatic plants (see the storm water wetland details in Figure 10.7 and Figure 10.8).

Wetlands created to mitigate disturbance impacts, such as filling, may not also be used as storm water treatment facilities. This is because of the different, incompatible functions of the two kinds of wetlands. Mitigation wetlands are intended to function as full replacement habitat for fish and wildlife, providing the same functions and harboring the same species diversity and biotic richness as the wetlands they replace. Storm water treatment wetlands are used to capture and transform pollutants, just as wetponds are, and over time pollutants will concentrate in the sediment. This is not a healthy environment for aquatic life. Storm water treatment wetlands are used to capture pollutants in a managed environment so that they will not reach natural wetlands and other ecologically important habitats. In addition, vegetation must occasionally be harvested and sediment dredged in storm water treatment wetlands, further interfering with use for wildlife habitat.

In general, storm water wetlands perform well to remove sediment, metals, and pollutants that bind to humic or organic acids. Phosphorus removal in storm water wetlands is highly variable.

### ***Applications and Limitations***

This storm water wetland design occupies about the same surface area as wetponds, but has the potential to be better integrated aesthetically into a site because of the abundance of emergent aquatic vegetation. The most critical factor for a successful design is the provision of an adequate supply of water for most of the year. Careful planning is needed to be sure sufficient water will be retained to sustain good wetland plant growth. Since water depths are shallower than in wetponds, water loss by evaporation is an important concern. Storm water wetlands are a good WQ facility choice in areas with high winter groundwater levels.

### ***Design Criteria***

When used for storm water treatment, storm water wetlands employ some of the same design features as wetponds. However, instead of gravity settling being the dominant treatment process, pollutant removal mediated by aquatic vegetation and the microbiological community associated with that vegetation becomes the dominant treatment process. Thus when designing wetlands, water volume is not the dominant design

criteria. Rather, factors which affect plant vigor and biomass are the primary concerns.

### **Sizing Procedure**

*Step 1:* The volume of a basic wetpond is used as a template for sizing the storm water wetland. The design volume is the total volume of runoff from the 6-month, 24-hour storm event.

*Step 2:* Calculate the surface area of the storm water wetland. The surface area of the wetland shall be the same as the top area of a wetpond sized for the same site conditions. Calculate the surface area of the storm water wetland by using the volume from Step 1 and dividing by the average water depth (use 3 feet).

*Step 3:* Determine the surface area of the first cell of the storm water wetland. Use the volume determined from Criterion 2 under "Wetland Geometry", and the actual depth of the first cell.

*Step 4:* Determine the surface area of the wetland cell. Subtract the surface area of the first cell (Step 3) from the total surface area (Step 2).

*Step 5:* Determine water depth distribution in the second cell. Decide if the top of the dividing berm will be at the surface or submerged (designer's choice). Adjust the distribution of water depths in the second cell according to Criterion 8 under "Wetland Geometry" below. Note: This will result in a facility that holds less volume than that determined in Step 1 above. This is acceptable.

**Intent:** The surface area of the storm water wetland is set to be roughly equivalent to that of a wetpond designed for the same site so as not to discourage use of this option.

*Step 6:* Choose plants. See Table 10.1 for a list of plants recommended for wetpond water depth zones, or consult a wetland scientist.

### **Wetland Geometry**

1. Storm water wetlands shall consist of two cells, a presettling cell and a wetland cell.
2. The presettling cell shall contain approximately 33 percent of the wetpool volume calculated in Step 1 above.
3. The depth of the presettling cell shall be between 4 feet (minimum) and 8 feet (maximum), excluding sediment storage.
4. One-foot of sediment storage shall be provided in the presettling cell.
5. The wetland cell shall have an average water depth of about 1.5 feet (plus or minus 3 inches).
6. The "berm" separating the two cells shall be shaped such that its downstream side gradually slopes to form the second shallow wetland cell (see the section view in Figure 10.7). Alternatively, the second

cell may be graded naturalistically from the top of the dividing berm (see Criterion 8 below).

7. The top of berm shall be either at the WQ design water surface or submerged 1-foot below the WQ design water surface, as with wetponds. Correspondingly, the side slopes of the berm must meet the following criteria:
  - a. If the top of berm is at the WQ design water surface, the berm side slopes shall be no steeper than 3H:1V.
  - b. If the top of berm is submerged 1-foot, the upstream side slope may be up to 2H:1V. If the berm is at the water surface, then for safety reasons, its slope should be not greater than 3:1, just as the pond banks should not be greater than 3:1 if the pond is not fenced. A steeper slope (2:1 rather than 3:1) is allowable if the berm is submerged in 1 foot of water. If submerged, the berm is not considered accessible, and the steeper slope is allowable.
8. Two examples are provided for grading the bottom of the wetland cell. One example is a shallow, evenly graded slope from the upstream to the downstream edge of the wetland cell (see Figure 10.7). The second example is a "naturalistic" alternative, with the specified range of depths intermixed throughout the second cell (see Figure 10.8). A distribution of depths shall be provided in the wetland cell depending on whether the dividing berm is at the water surface or submerged (see Table 10.2 below). The maximum depth is 2.5 feet in either configuration.

### **Lining Requirements**

In infiltrative soils, both cells of the storm water wetland shall be lined. To determine whether a low-permeability liner or a treatment liner is required, determine whether the following conditions will be met. If soil permeability will allow sufficient water retention, lining may be waived.

1. The second cell must retain water for at least 10 months of the year.
2. The first cell must retain at least three feet of water year-round.
3. A complete precipitation record shall be used when establishing these conditions. Evapotranspiration losses shall be taken into account as well as infiltration losses.

**Intent:** Many wetland plants can adapt to periods of summer drought, so a limited drought period is allowed in the second cell. This may allow a treatment liner rather than a low permeability liner to be used for the second cell. The first cell must retain water year-round in order for the presettling function to be effective.

- If a low permeability liner is used, a minimum of 18 inches of native soil amended with good topsoil or compost (one part compost mixed with 3 parts native soil) must be placed over the liner. For geomembrane liners, a soil depth of 3 feet is recommended to prevent damage to the liner during planting. Hydric soils are not required.

The criteria for liners given in Chapter 4 must be observed.

### **Inlet and Outlet**

Same as for wetponds (see BMP T10.10).

### **Access and Setbacks**

Also See Setback Requirements and Site Constraints in Sections 4.3.1 and 4.3.2

- Location of the storm water wetland relative to site constraints (e.g., buildings, property lines, etc.) shall be the same as for detention ponds (see Volume III).
- Access and maintenance roads shall be provided and designed according to the requirements for detention ponds (see Volume III). Access and maintenance roads shall extend to both the wetland inlet and outlet structures. An access ramp (7H minimum:1V) shall be provided to the bottom of the first cell unless all portions of the cell can be reached and sediment loaded from the top of the wetland side slopes.
- If the dividing berm is also used for access, it should be built to sustain loads of up to 80,000 pounds.

### **Planting Requirements**

The wetland cell shall be planted with emergent wetland plants following the recommendations given in Table 10.1 or the recommendations of a wetland specialist. Note: Cattails (*Typha latifolia*) are not recommended. They tend to escape to natural wetlands and crowd out other species. In addition, the shoots die back each fall and will result in oxygen depletion in the wetpool unless they are removed.

### **Construction Criteria:**

- Construction and maintenance considerations are the same as for wetponds.
- Construction of the naturalistic alternative (Option 2) can be easily done by first excavating the entire area to the 1.5-foot average depth. Then soil subsequently excavated to form deeper areas can be deposited to raise other areas until the distribution of depths indicated in the design is achieved.

### **Operation and Maintenance**

- Wetlands should be inspected at least twice per year during the first three years during both growing and non-growing seasons to observe plant species presence, abundance, and condition; bottom contours and water depths relative to plans; and sediment, outlet, and buffer conditions.
- Maintenance should be scheduled around sensitive wildlife and vegetation seasons.

- Plants may require watering, physical support, mulching, weed removal, or replanting during the first three years.
- Nuisance plant species should be removed and desirable species should be replanted.
- The effectiveness of harvesting for nutrient control is not well documented. There are many drawbacks to harvesting, including possible damage to the wetlands and the inability to remove nutrients in the below-ground biomass. If harvesting is practiced, it should be done in the late summer.

### **Resource Material**

King County Surface Water Design Manual, September 1998.

Schueler, Thomas. Design of Stormwater Wetland Systems, Guidelines for Creating Diverse and Effective Stormwater Wetland Systems in the Mid-Atlantic Region. October, 1992.

Kadlec, Robert and Robert L. Knight. Treatment Wetlands. 1996.

## **BMP T10.40 Combined Detention and Wetpool Facilities**

### ***Purpose and Definition:***

Combined detention and WQ wetpool facilities have the appearance of a detention facility but contain a permanent pool of water as well. The following design procedures, requirements, and recommendations cover differences in the design of the stand-alone WQ facility when combined with detention storage. The following combined facilities are addressed:

- Detention/wetpond (basic and large)
- Detention/wetvault
- Detention/storm water wetland.

There are two sizes of the combined wetpond, a basic and a large, but only a basic size for the combined wetvault and combined storm water wetland. The facility sizes (basic and large) are related to the pollutant removal goals. See Chapter 3 for more information about treatment performance goals.

### ***Applications and Limitations:***

Combined detention and water quality facilities are very efficient for sites that also have detention requirements. The water quality facility may often be placed beneath the detention facility without increasing the facility surface area. However, the fluctuating water surface of the live storage will create unique challenges for plant growth and for aesthetics alike.

The basis for pollutant removal in combined facilities is the same as in the stand-alone WQ facilities. However, in the combined facility, the detention function creates fluctuating water levels and added turbulence. For simplicity, the positive effect of the extra live storage volume and the negative effect of increased turbulence are assumed to balance, and are thus ignored when sizing the wetpool volume. For the combined detention/storm water wetland, criteria that limit the extent of water level fluctuation are specified to better ensure survival of the wetland plants.

Unlike the wetpool volume, the live storage component of the facility should be provided above the seasonal high water table.

### **Combined Detention and Wetpond (Basic and Large)**

Typical design details and concepts for a combined detention and wetpond are shown in Figures 10.9 and 10.10. The detention portion of the facility shall meet the design criteria and sizing procedures set forth in Volume 3.

### **Sizing Procedure**

The sizing procedure for combined detention and wetponds are identical to those outlined for wetponds and for detention facilities. The wetpool volume for a combined facility shall be equal to or greater than the total volume of runoff from the 6-month, 24-hour storm event. Follow the

standard procedure specified in Volume III to size the detention portion of the pond.

### **Detention and Wetpool Geometry**

- The wetpool and sediment storage volumes shall not be included in the required detention volume.
- The "Wetpool Geometry" criteria for wetponds (see BMP T10.10) shall apply with the following modifications/clarifications:

*Criterion 1:* The permanent pool may be made shallower to take up most of the pond bottom, or deeper and positioned to take up only a limited portion of the bottom. Note, however, that having the first wetpool cell at the inlet allows for more efficient sediment management than if the cell is moved away from the inlet. Wetpond criteria governing water depth must, however, still be met. See Figure 10.11 for two possibilities for wetpool cell placement.

**Intent:** This flexibility in positioning cells is provided to allow for multiple use options, such as volleyball courts in live storage areas in the drier months.

*Criterion 2:* The minimum sediment storage depth in the first cell is 1-foot. The 6 inches of sediment storage required for detention ponds does not need to be added to this, but 6 inches of sediment storage must be added to the second cell to comply with the detention sediment storage requirement.

### **Berms, Baffles, and Slopes**

Same as for wetponds (see BMP T10.10).

### **Inlet and Outlet**

The "Inlet and Outlet" criteria for wetponds shall apply with the following modifications:

- A sump must be provided in the outlet structure of combined ponds.
- The detention flow restrictor and its outlet pipe shall be designed according to the requirements for detention ponds (see Volume III).

### **Access and Setbacks**

Same as for wetponds.

### **Planting Requirements**

Same as for wetponds.

### **Combined Detention and Wetvault**

The sizing procedure for combined detention and wetvaults is identical to those outlined for wetvaults and for detention facilities. The wetvault volume for a combined facility shall be equal to or greater than the total volume of runoff from the 6-month, 24-hour storm event. Follow the standard procedure specified in Volume 3 to size the detention portion of the vault.

The design criteria for detention vaults and wetvaults must both be met, except for the following modifications or clarifications:



- The minimum sediment storage depth in the first cell shall average 1-foot. The 6 inches of sediment storage required for detention vaults does not need to be added to this, but 6 inches of sediment storage must be added to the second cell to comply with detention vault sediment storage requirements.
- The oil retaining baffle shall extend a minimum of 2 feet below the WQ design water surface.

**Intent:** The greater depth of the baffle in relation to the WQ design water surface compensates for the greater water level fluctuations experienced in the combined vault. The greater depth is deemed prudent to better ensure that separated oils remain within the vault, even during storm events.

*Note:* If a vault is used for detention as well as water quality control, the facility may not be modified to function as a baffle oil/water separator as allowed for wetvaults in BMP T10.20. This is because the added pool fluctuation in the combined vault does not allow for the quiescent conditions needed for oil separation.

### **Combined Detention and Storm Water Wetland**

The sizing procedure for combined detention and storm water wetlands is identical to those outlined for storm water wetlands and for detention facilities. Follow the procedure specified in BMP T10.30 to determine the storm water wetland size. Follow the standard procedure specified in Volume III to size the detention portion of the wetland.

The design criteria for detention ponds and storm water wetlands must both be met, except for the following modifications or clarifications:

- The "Wetland Geometry" criteria for storm water wetlands (see BMP T10.30) are modified as follows:
- The minimum sediment storage depth in the first cell is 1-foot. The 6 inches of sediment storage required for detention ponds does not need to be added to this, nor does the 6 inches of sediment storage in the second cell of detention ponds need to be added.

**Intent:** Since emergent plants are limited to shallower water depths, the deeper water created before sediments accumulate is considered detrimental to robust emergent growth. Therefore, sediment storage is confined to the first cell which functions as a presettling cell.

The "Inlet and Outlet" criteria for wetponds shall apply with the following modifications:

- A sump must be provided in the outlet structure of combined facilities.
- The detention flow restrictor and its outlet pipe shall be designed according to the requirements for detention ponds (see Volume III).

The "Planting Requirements" for storm water wetlands are modified to use the following plants which are better adapted to water level fluctuations:

Scirpus acutus (hardstem bulrush)	2 - 6' depth
Scirpus microcarpus (small-fruited bulrush)	1 - 2.5' depth
Sparganium emersum (burreed)	1 - 2' depth
Sparganium eurycarpum (burreed)	1 - 2' depth
Veronica sp. (marsh speedwell)	0 - 1' depth

In addition, the shrub *Spirea douglasii* (Douglas spirea) may be used in combined facilities.

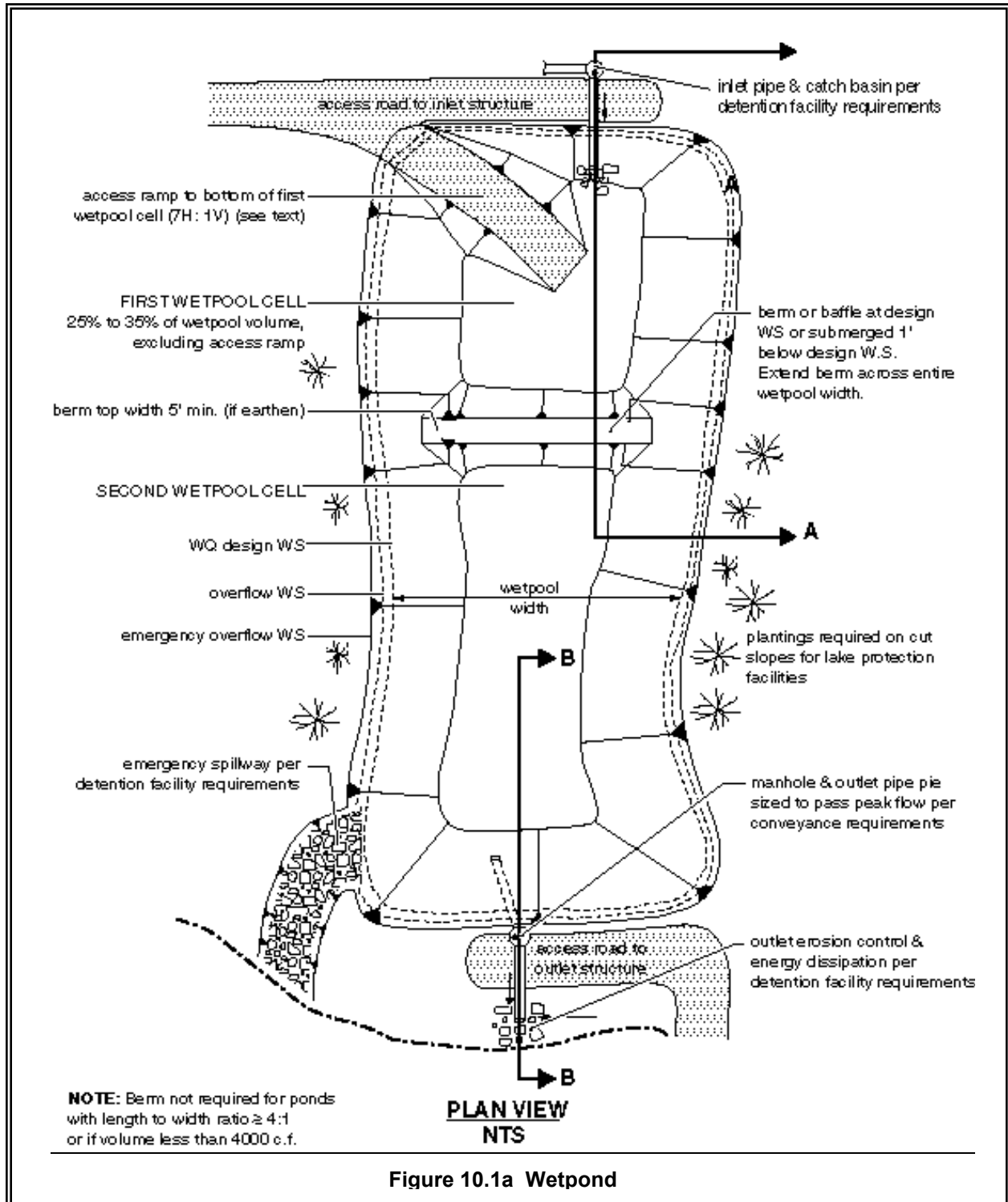
**Water Level Fluctuation Restrictions:** The difference between the WQ design water surface and the maximum water surface associated with the 2-year runoff shall not be greater than 3 feet. If this restriction cannot be met, the size of the storm water wetland must be increased. The additional area may be placed in the first cell, second cell, or both. If placed in the second cell, the additional area need not be planted with wetland vegetation or counted in calculating the average depth.

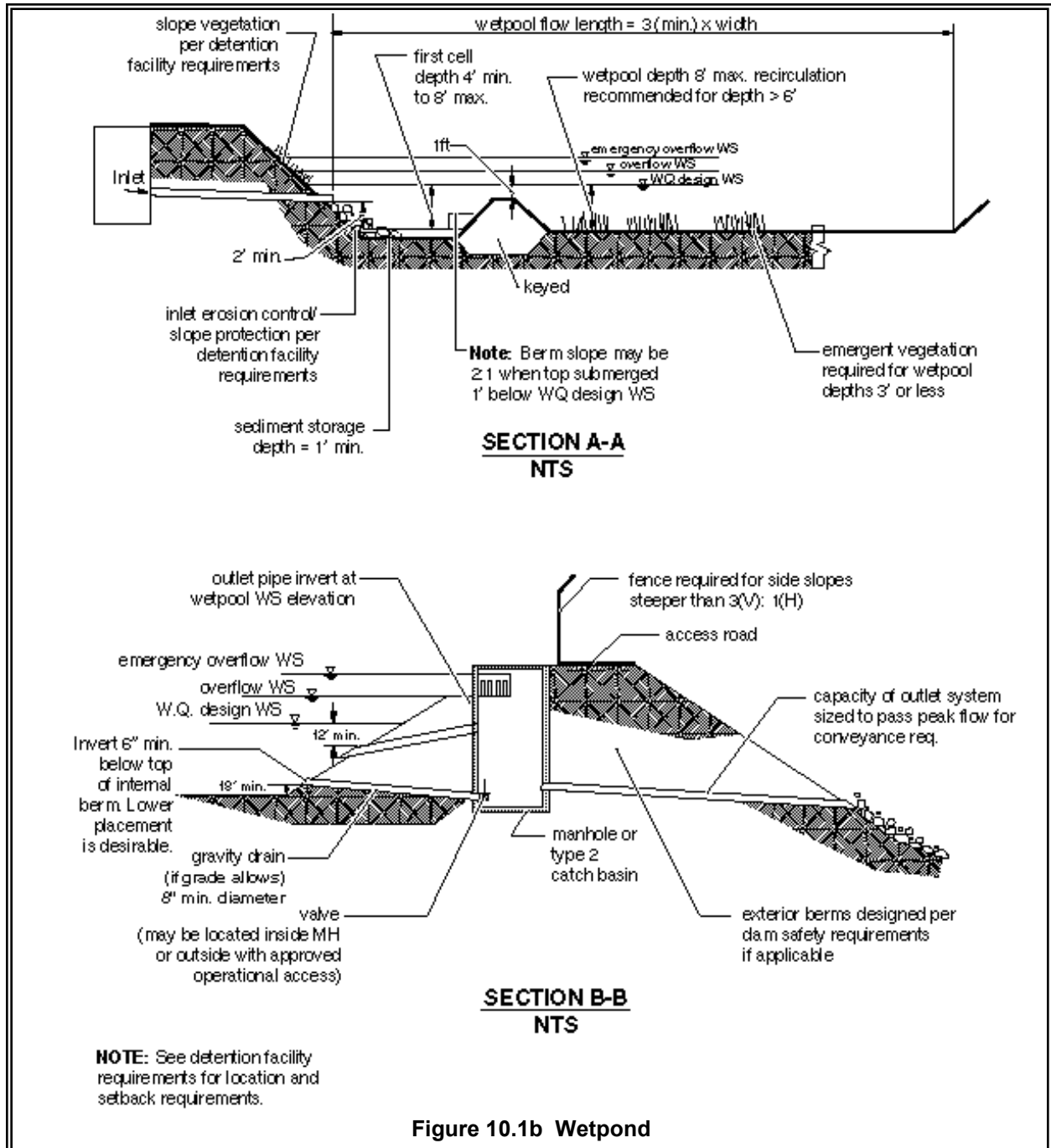
**Intent:** This criterion is designed to dampen the most extreme water level fluctuations expected in combined facilities to better ensure that fluctuation-tolerant wetland plants will be able to survive in the facility. It is not intended to protect native wetland plant communities and is not to be applied to natural wetlands.

**Table 10.1 -- Emergent wetland plant species recommended for wetponds**

Species	Common Name	Notes	Maximum Depth
<b>INUNDATION TO 1-FOOT</b>			
<i>Agrostis exarata</i> <sup>(1)</sup>	Spike bent grass	Prairie to coast	to 2 feet
<i>Carex stipata</i>	Sawbeak sedge	Wet ground	
<i>Eleocharis palustris</i>	Spike rush	Margins of ponds, wet meadows	to 2 feet
<i>Glyceria occidentalis</i>	Western mannagrass	Marshes, pond margins	to 2 feet
<i>Juncus tenuis</i>	Slender rush	Wet soils, wetland margins	
<i>Oenanthe sarmentosa</i>	Water parsley	Shallow water along stream and pond margins; needs saturated soils all summer	
<i>Scirpus atrocinctus</i> (formerly <i>S. cyperinus</i> )	Woolgrass	Tolerates shallow water; tall clumps	
<i>Scirpus microcarpus</i>	Small-fruited bulrush	Wet ground to 18 inches depth	18 inches
<i>Sagittaria latifolia</i>	Arrowhead		
<b>INUNDATION 1 TO 2 FEET</b>			
<i>Agrostis exarata</i> <sup>(1)</sup>	Spike bent grass	Prairie to coast	
<i>Alisma plantago-aquatica</i>	Water plantain		
<i>Eleocharis palustris</i>	Spike rush	Margins of ponds, wet meadows	
<i>Glyceria occidentalis</i>	Western mannagrass	Marshes, pond margins	
<i>Juncus effusus</i>	Soft rush	Wet meadows, pastures, wetland margins	
<i>Scirpus microcarpus</i>	Small-fruited bulrush	Wet ground to 18 inches depth	18 inches
<i>Sparganium emmersum</i>	Bur reed	Shallow standing water, saturated soils	
<b>INUNDATION 1 TO 3 FEET</b>			
<i>Carex obnupta</i>	Slough sedge	Wet ground or standing water	1.5 to 3 feet
<i>Beckmania syzigachne</i> <sup>(1)</sup>	Western sloughgrass	Wet prairie to pond margins	
<i>Scirpus acutus</i> <sup>(2)</sup>	Hardstem bulrush	Single tall stems, not clumping	to 3 feet
<i>Scirpus validus</i> <sup>(2)</sup>	Softstem bulrush		
<b>INUNDATION GREATER THAN 3 FEET</b>			
<i>Nuphar polysepalum</i>	Spatterdock	Deep water	3 to 7.5 feet
<i>Nymphaea odorata</i> <sup>(1)</sup>	White waterlily	Shallow to deep ponds	to 6 feet
<p><b>Notes:</b></p> <p><sup>(1)</sup> Non-native species. <i>Beckmania syzigachne</i> is native to Oregon. Native species are preferred.</p> <p><sup>(2)</sup> <i>Scirpus</i> tubers must be planted shallower for establishment, and protected from foraging waterfowl until established. Emerging aerial stems should project above water surface to allow oxygen transport to the roots.</p> <p>Primary sources: Municipality of Metropolitan Seattle, <i>Water Pollution Control Aspects of Aquatic Plants</i>, 1990. Hortus Northwest, <i>Wetland Plants for Western Oregon</i>, Issue 2, 1991. Hitchcock and Cronquist, <i>Flora of the Pacific Northwest</i>, 1973.</p>			

<b>Table 10.2 – Distribution of depths in wetland cell</b>			
<b>Dividing Berm at WQ Design Water Surface</b>		<b>Dividing Berm Submerged 1-Foot</b>	
<b>Depth Range (feet)</b>	<b>Percent</b>	<b>Depth Range (feet)</b>	<b>Percent</b>
0.1 to 1	25	1 to 1.5	40
1 to 2	55	1.5 to 2	40
2 to 2.5	20	2 to 2.5	20





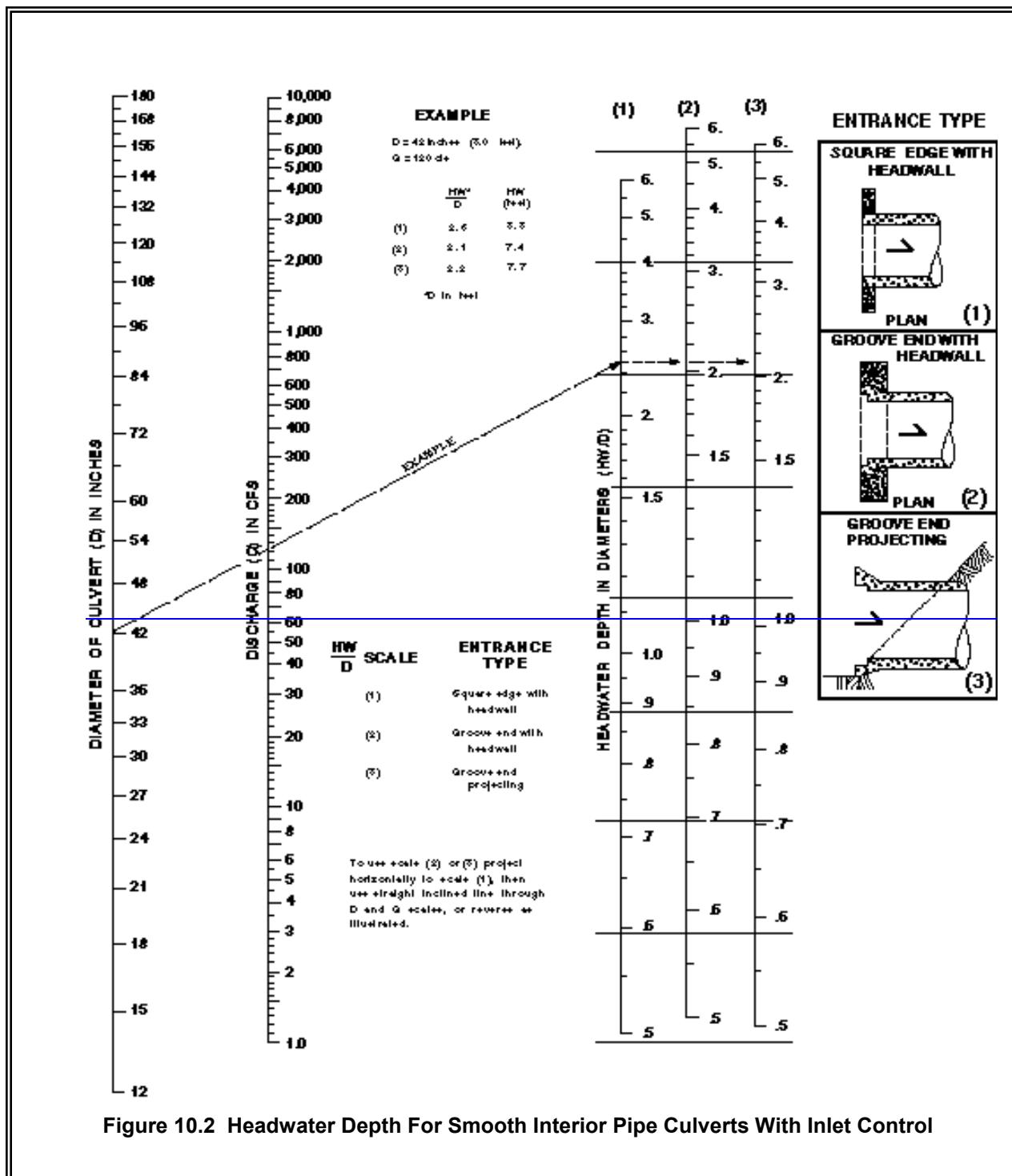


Figure 10.2 Headwater Depth For Smooth Interior Pipe Culverts With Inlet Control

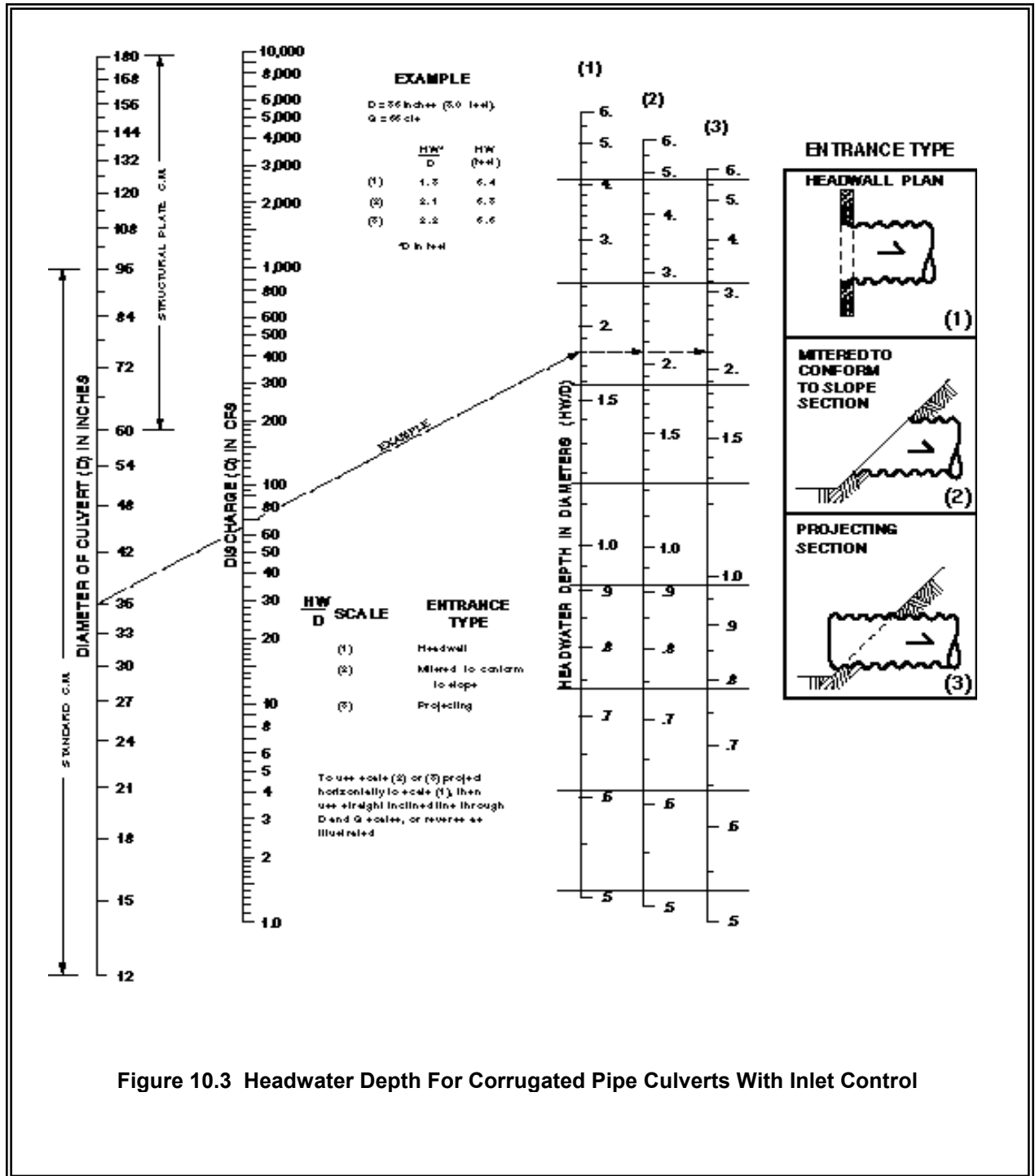


Figure 10.3 Headwater Depth For Corrugated Pipe Culverts With Inlet Control



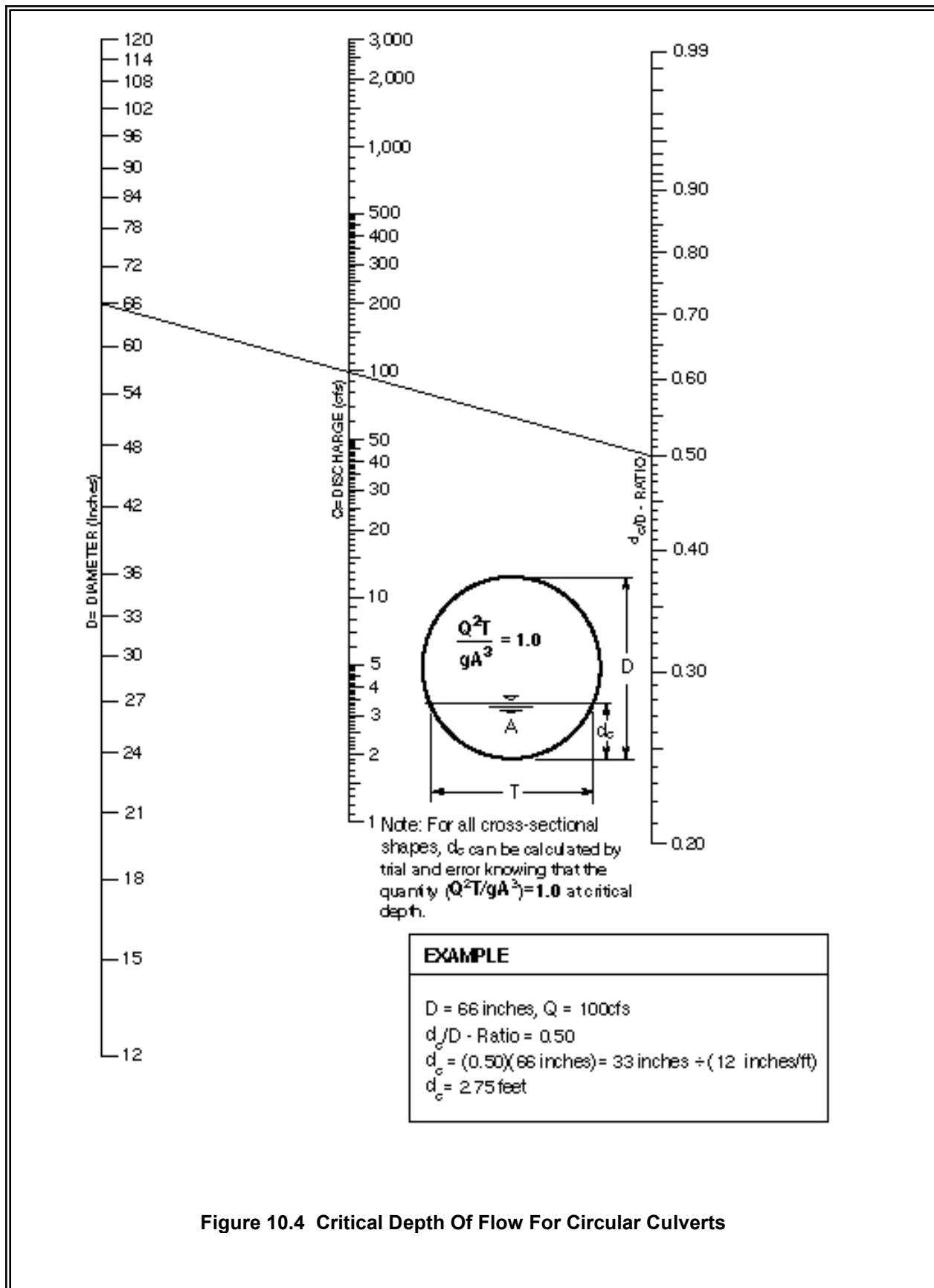
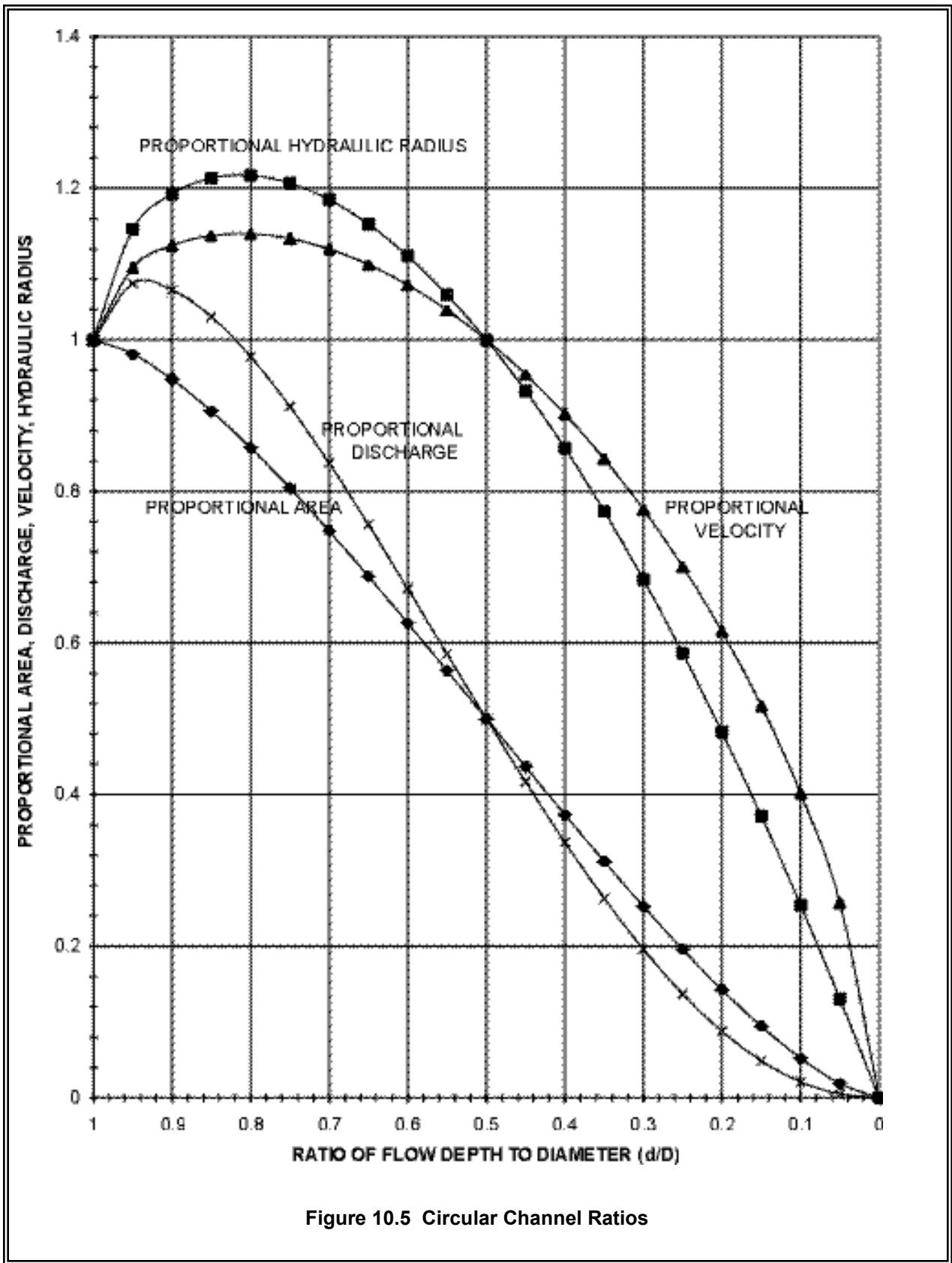
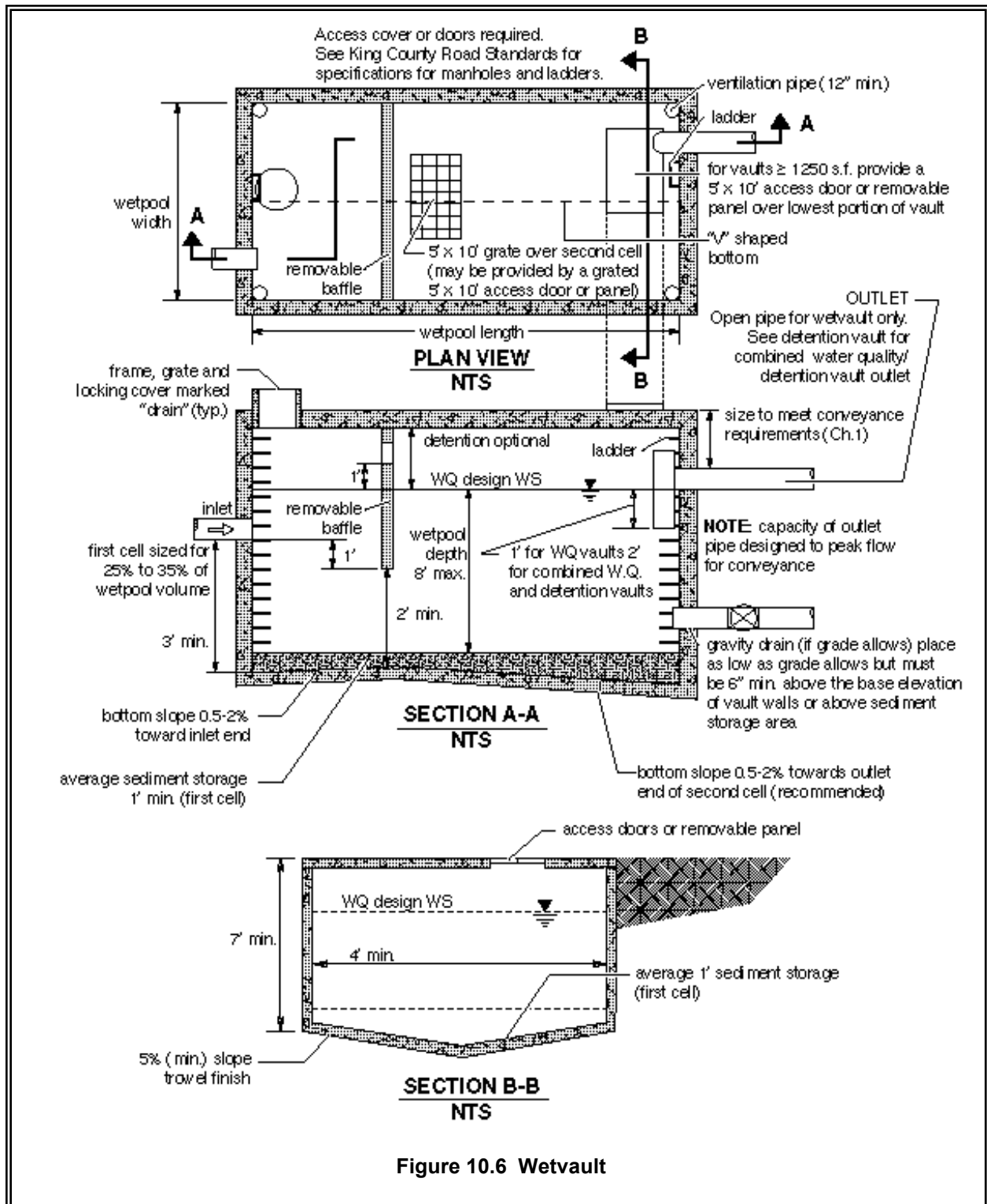
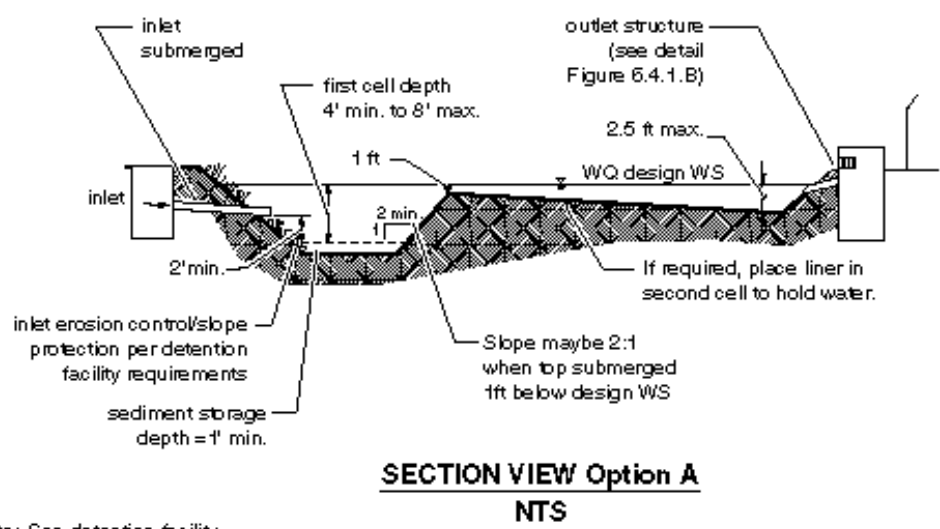
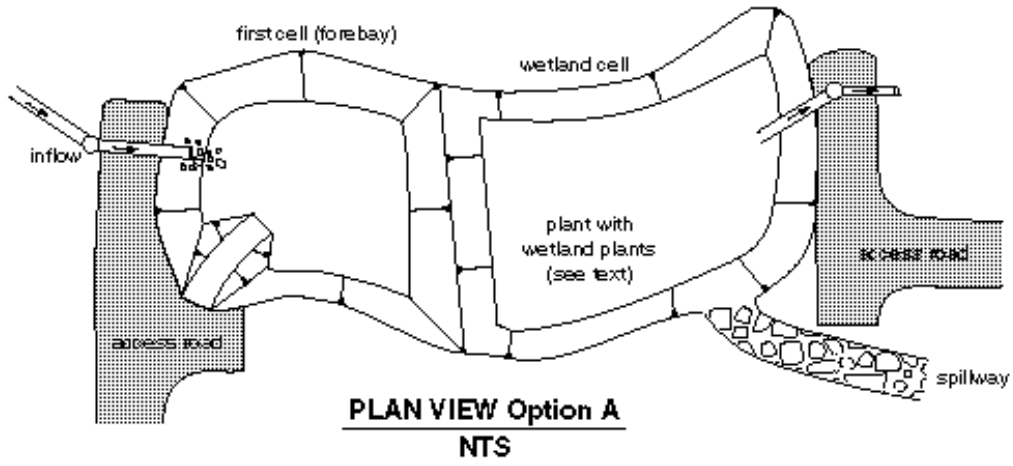


Figure 10.4 Critical Depth Of Flow For Circular Culverts







Note: See detention facility requirements for location and setback requirements.

Figure 10.7 Stormwater Wetland — Option One

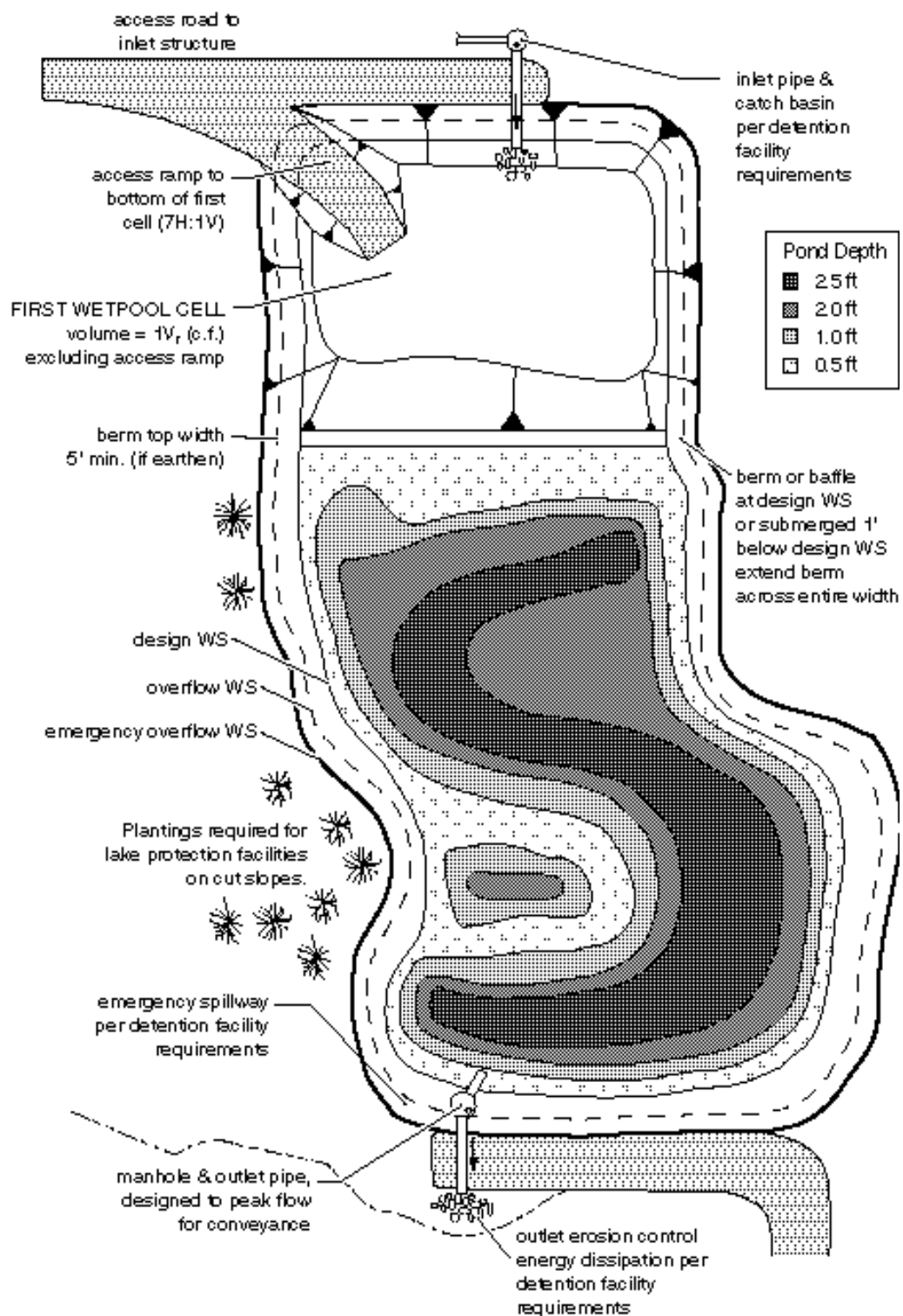


Figure 10.8 Stormwater Wetland  
— Option Two

PLAN VIEW Option B  
NTS

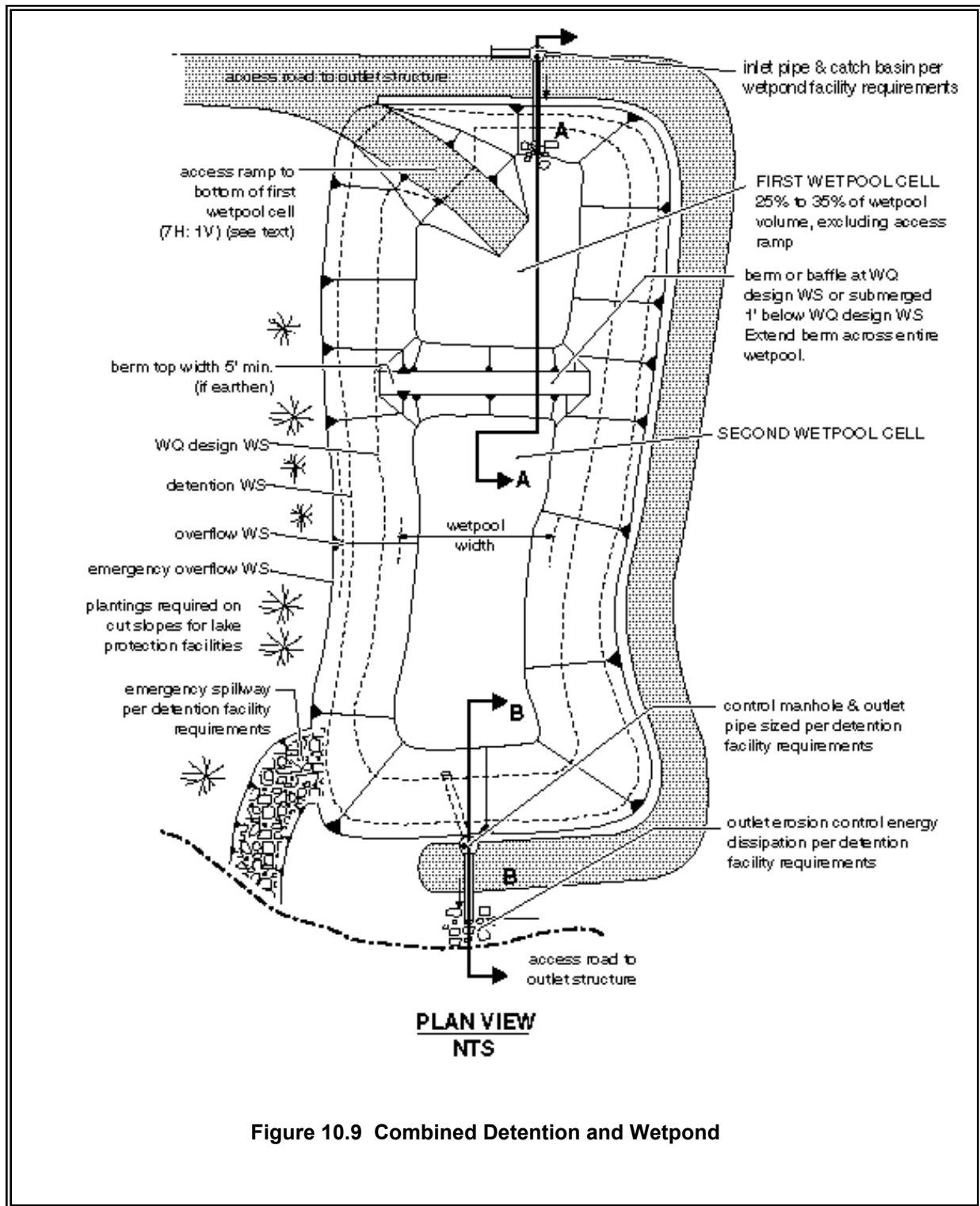


Figure 10.9 Combined Detention and Wetpond

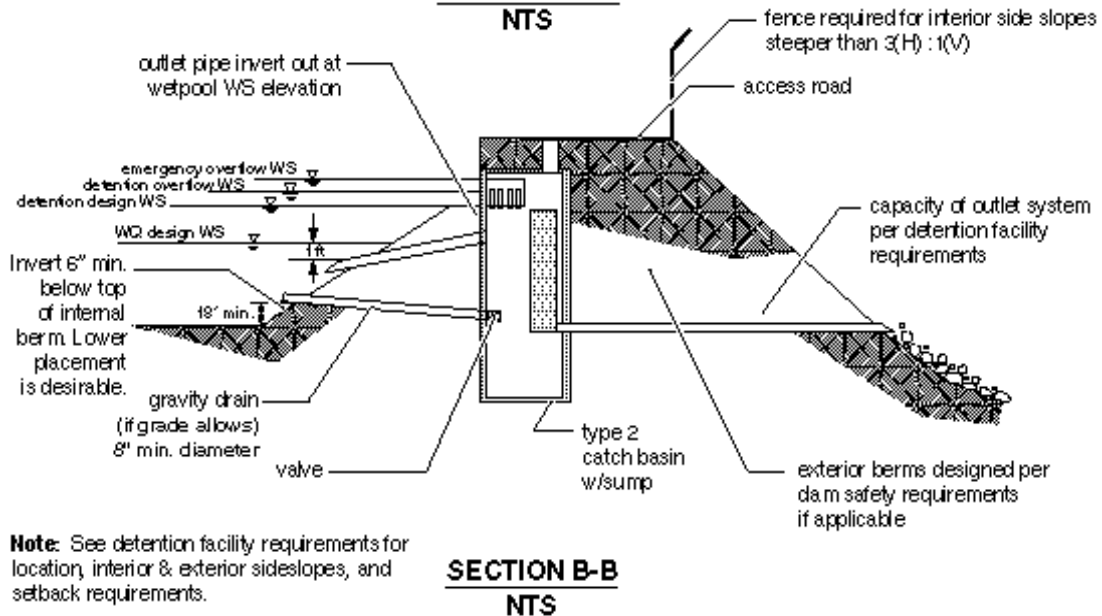
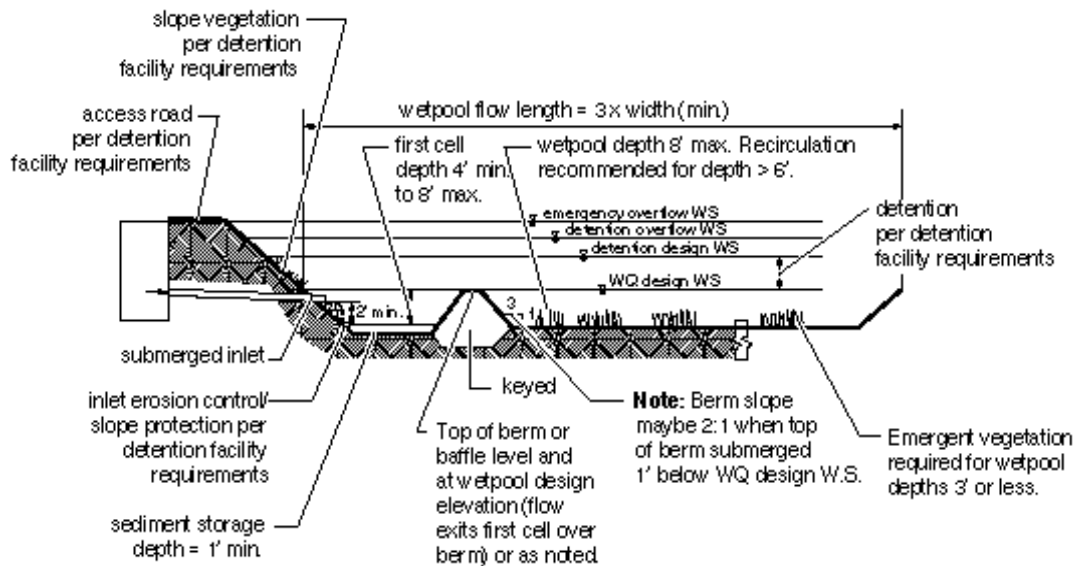
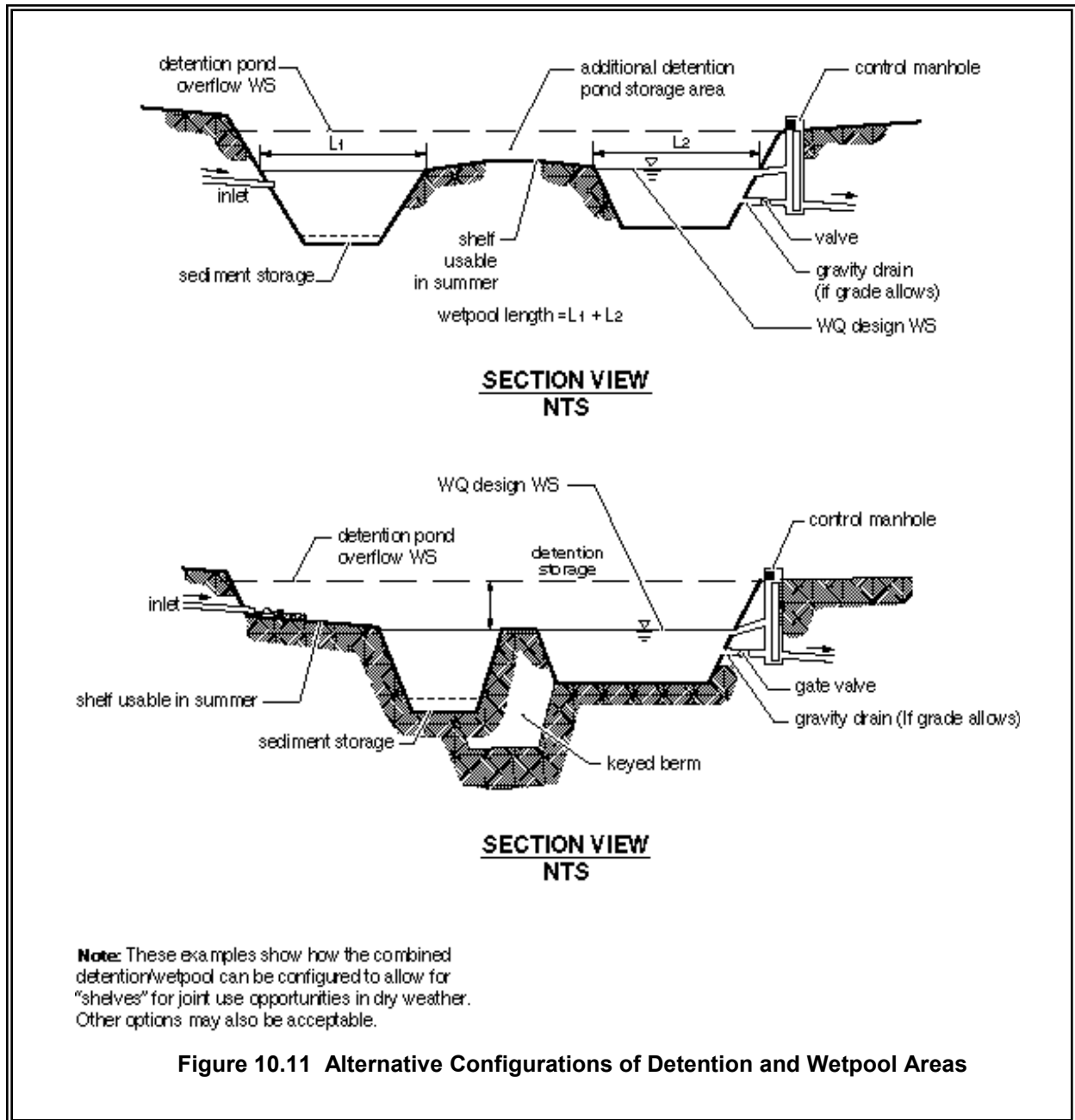


Figure 10.10 Combined Detention and Wetpond (Continued)





# Chapter 11 - Oil and Water Separators

---

This chapter provides a discussion of oil and water separators, including their application and design criteria. BMPs are described for baffle type and coalescing plate separators.

## 11.1 Purpose of Oil and Water Separators

To remove oil and other water-insoluble hydrocarbons, and settleable solids from storm water runoff.

## 11.2 Description

Oil and water separators are typically the American Petroleum Institute (API) (also called baffle type) (American Petroleum Institute, 1990) or the coalescing plate (CP) type using a gravity mechanism for separation. See Figures 11.1 and 11.2. Oil removal separators typically consist of three bays; forebay, separator section, and the afterbay. The CP separators need considerably less space for separation of the floating oil due to the shorter travel distances between parallel plates. A spill control (SC) separator (Figure 11.3) is a simple catchbasin with a T-inlet for temporarily trapping small volumes of oil. The spill control separator is included here for comparison only and is not designed for, or to be used for treatment purposes.

## 11.3 Performance Objectives

Oil and water separators should be designed to remove oil and TPH down to 15 mg/L at any time and 10 mg/L on a 24-hr average, and produce a discharge that does not cause an ongoing or recurring visible sheen in the storm water discharge, or in the receiving water (see also Chapter 3).

## 11.4 Applications/Limitations

The following are potential applications of oil and water separators where free oil is expected to be present at treatable high concentrations and sediment will not overwhelm the separator. (Seattle METRO, 1990; Watershed Protection Techniques, 1994; King County Surface Water Management, 1998) For low concentrations of oil, other treatments may be more applicable. These include sand filters and emerging technologies.

- Commercial and industrial areas including petroleum storage yards, vehicle maintenance facilities, manufacturing areas, airports, utility areas (water, electric, gas), and fueling stations. (King County Surface Water Management, 1998)
- Facilities that would require oil control BMPs under the high-use site threshold described in Chapter 2 including parking lots at convenience stores, fast food restaurants, grocery stores, shopping malls, discount

warehouse stores, banks, truck fleets, auto and truck dealerships, and delivery services. (King County Surface Water Management, 1998)

- Without intense maintenance oil/water separators may not be sufficiently effective in achieving oil and TPH removal down to required levels.
- Pretreatment should be considered if the level of TSS in the inlet flow would cause clogging or otherwise impair the long-term efficiency of the separator.
- For inflows from small drainage areas (fueling stations, maintenance shops, etc.) a coalescing plate (CP) type separator is typically considered, due to space limitations. However, if plugging of the plates is likely, then a new design basis for the baffle type API separator may be considered on an experimental basis (see 11.6 Design Criteria).

## 11.5 Site Suitability

Consider the following site characteristics:

- Sufficient land area
- Adequate TSS control or pretreatment capability
- Compliance with environmental objectives
- Adequate influent flow attenuation and/or bypass capability
- Sufficient access for operation and maintenance (O & M)

## 11.6 Design Criteria-General Considerations

There is concern that oil/water separators used for storm water treatment have not performed to expectations. (Watershed Protection Techniques, 1994; Schueler, Thomas R., 1990) Therefore, emphasis should be given to proper application (see Section 11.4), design, O & M, (particularly sludge and oil removal) and prevention of CP fouling and plugging. (US Army of Engineers, 1994) Other treatment systems, such as sand filters and emerging technologies, should be considered for the removal of insoluble oil and TPH.

The following are design criteria applicable to API and CP oil/water separators:

- If practicable, determine oil/grease (or TPH) and TSS concentrations, lowest temperature, pH; and empirical oil rise rates in the runoff, and the viscosity, and specific gravity of the oil. Also determine whether the oil is emulsified or dissolved. (Washington State Department of Ecology, 1995) Do not use oil/water separators for the removal of dissolved or emulsified oils such as coolants, soluble lubricants, glycols, and alcohols.
- Locate the separator off-line and bypass flows in excess of 2.15 times the Water Quality design flow rate.
- Use only impervious conveyances for oil contaminated storm water.

- Specify appropriate performance tests after installation and shakedown, and/or certification by a professional engineer that the separator is functioning in accordance with design objectives. Expedient corrective actions must be taken if it is determined the separator is not achieving acceptable performance levels.
- Add pretreatment for TSS that could cause clogging of the CP separator, or otherwise impair the long-term effectiveness of the separator.

**Criteria for Separator Bays:**

- Size the separator bay for the Water Quality design flow rate x a correction factor of 2.15 (see Chapter 4 of this Volume for a definition of the Water Quality Design Flow Rate).
- To collect floatables and settleable solids, design the surface area of the forebay at  $\geq 20 \text{ ft}^2$  per 10,000  $\text{ft}^2$  of area draining to the separator <sup>(6)</sup>. The length of the forebay should be 1/3-1/2 of the length of the entire separator. Include roughing screens for the forebay or upstream of the separator to remove debris, if needed. Screen openings should be about 3/4 inch.
- Include a submerged inlet pipe with a turn-down elbow in the first bay at least two feet from the bottom. The outlet pipe should be a Tee, sized to pass the design peak flow and placed at least 12 inches below the water surface.
- Include a shutoff mechanism at the separator outlet pipe. (King County Surface Water Management, 1998)
- Use absorbents and/or skimmers in the afterbay as needed.

**Criteria for Baffles:**

- Oil retaining baffles (top baffles) should be located at least at 1/4 of the total separator length from the outlet and should extend down at least 50% of the water depth and at least 1 ft. from the separator bottom.
- Baffle height to water depth ratios should be 0.85 for top baffles and 0.15 for bottom baffles.

## **11.7 Oil and Water Separator BMPs**

Two BMPs are described in this section. BMP T11.10 for baffle type separators, and BMP T11.11 for coalescing plate separators.

## **BMP T11.10 API (Baffle type) Separator Bay**

### **Design Criteria:**

The criteria for small drainages is based on  $V_h$ ,  $V_t$ , residence time, width, depth, and length considerations. As a correction factor API's turbulence criteria is applied to increase the length.

Ecology is modifying the API criteria for treating storm water runoff from small drainage area (fueling stations, commercial parking lots, etc.) by using the design hydraulic horizontal velocity,  $V_h$ , for the design  $V_h/V_t$  ratio rather than the API minimum of  $V_h/V_t = 15$ . The API criteria appear applicable for greater than two acres of impervious drainage area. Performance verification of this design basis must be obtained during at least one wet season using the test protocol referenced in Chapter 12 for new technologies.

The following is the sizing procedure using modified API criteria:

- Determine the oil rise rate,  $V_t$ , in cm/sec, using Stokes Law (Water Pollution Control Federation, 1985), or empirical determination, or 0.033 ft./min for 60 $\mu$  oil. The application of Stokes' Law to site-based oil droplet sizes and densities, or empirical rise rate determinations recognizes the need to consider actual site conditions. In those cases the design basis would not be the 60 micron droplet size and the 0.033 ft/min. rise rate.
- Stokes Law equation for rise rate,  $V_t$  (cm/sec):

$$V_t = g(\sigma_w - \sigma_o)D^2 / 18\eta_w$$

Where:

$g$  = gravitational constant (981 cm/sec<sup>2</sup>)

$D$  = diameter of the oil particle in cm.

Use

oil particle size diameter,  $D=60$  microns (0.006 cm)

$\sigma_w = 0.999$  gm/cc. at 32° F

$\sigma_o$ : Select conservatively high oil density,

For example, if diesel oil @  $\sigma_o=0.85$  gm/cc and motor oil @  $\sigma_o = 0.90$  can be present then use  $\sigma_o=0.90$  gm/cc

$\eta_w = 0.017921$  poise, gm/cm-sec. at  $T_w=32$  °F, (See API Publication 421, February , 1990)

Use the following separator dimension criteria:

Separator water depth,  $d \geq 3 \leq 8$  feet (to minimize turbulence).

(American Petroleum Institute, 1990; US Army Corps of Engineers, 1994)

Separator width, 6-20 feet (WEF & ASCE, 1998; King County Surface Water Management, 1998)

Depth/width ( $d/w$ ) of 0.3-0.5 (American Petroleum Institute, 1990)

**For Storm Water Inflow from Drainages under 2 Acres:**

1. Determine  $V_t$  and select depth and width of the separator section based on above criteria.
2. Calculate the minimum residence time ( $t_m$ ) of the separator at depth  $d$ :

$$t_m = d/V_t$$

3. Calculate the horizontal velocity of the bulk fluid,  $V_h$ , vertical cross-sectional area,  $A_v$ , and actual design  $V_h/V_t$  (American Petroleum Institute, 1990; US Army Corps of Engineers, 1994).

$$V_h = Q/dw = Q/A_v \text{ (} V_h \text{ maximum at } < 2.0 \text{ ft/min.) (American Petroleum Institute, 1990)}$$

$$Q = 2.15 \times \text{the Water Quality design flow rate in ft}^3/\text{min, at minimum residence time, } t_m$$

At  $V_h/V_t$  determine  $F$ , turbulence and short-circuiting factor (Appendix V-D) API  $F$  factors range from 1.28-1.74. (American Petroleum Institute, 1990)

4. Calculate the minimum length of the separator section,  $l(s)$ , using:

$$l(s) = FQt_m/wd = F(V_h/V_t)d$$

$$l(t) = l(f) + l(s) + l(a)$$

$$l(t) = l(t)/3 + l(s) + l(t)/4$$

Where:

$l(t)$  = total length of 3 bays

$l(f)$  = length of forebay

$l(a)$  = length of afterbay

5. Calculate  $V = l(s)wd = FQt_m$ , and  $A_h = wl(s)$

$V$  = minimum hydraulic design volume

$A_h$  = minimum horizontal area of the separator

**For Storm Water Inflow from Drainages > 2 Acres:**

Use  $V_h = 15 V_t$  and  $d = (Q/2V_h)^{1/2}$  (with  $d/w = 0.5$ ) and repeat above calculations 3- 5.

## **BMP T11.11 Coalescing Plate (CP) Separator Bay**

### **Design Criteria**

Calculate the projected (horizontal) surface area of plates needed using the following equation:

$$A_p = Q/V_t = Q/0.00386(\sigma_w - \sigma_o/\eta_w)$$

$$A_p = A_a(\cosine b)$$

Where:

$Q$  = 2.15 x the water quality design flow rate, ft<sup>3</sup>/min

$V_t$  = Rise rate of 0.033 ft/min, or empirical determination, or Stokes Law based

$A_p$  = projected surface area of the plate in ft<sup>2</sup>; .00386 is unit conversion constant

$\sigma_w$  = density of water at 32° F

$\sigma_o$  = density of oil at 32° F

$A_a$  = actual plate area in ft<sup>2</sup> (one side only)

$b$  = angle of the plates with the horizontal in degrees (usually varies from 45-60 degrees).

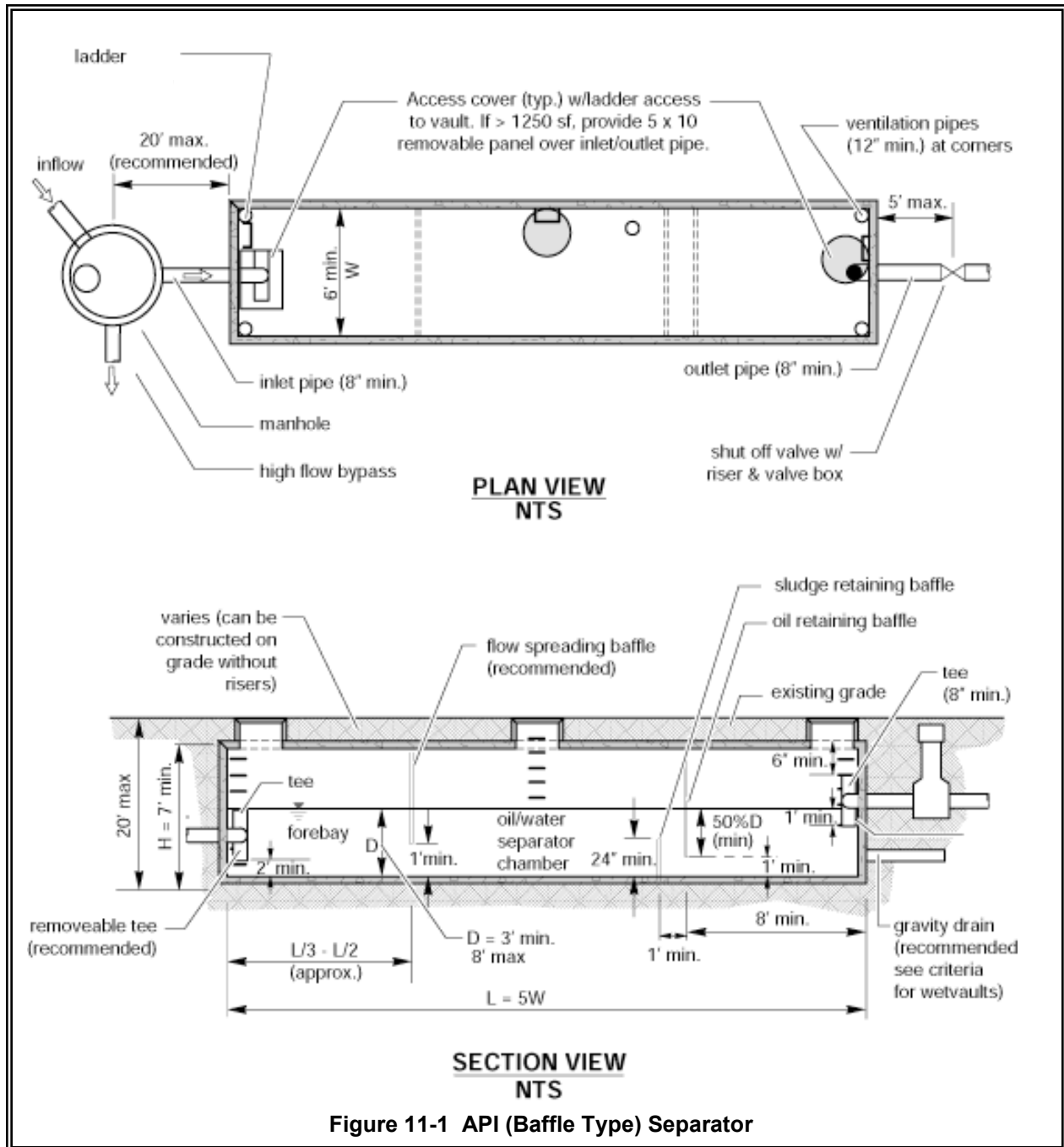
$\eta_w$  = viscosity of water at 32° F

- Plate spacing should be a minimum of 3/4 in (perpendicular distance between plates). (WEF & ASCE, 1998; US Army Corps of Engineers, 1994; US Air Force, 1991; Jaisinghani, R., 1979)
- Select a plate angle between 45° to 60° from the horizontal.
- Locate plate pack at least 6 inches from the bottom of the separator for sediment storage.
- Add 12 inches minimum head space from the top of the plate pack and the bottom of the vault cover.
- Design inlet flow distribution and baffles in the separator bay to minimize turbulence, short-circuiting, and channeling of the inflow especially through and around the plate packs of the CP separator. The Reynolds Number through the separator bay should be <500 (laminar flow).
- Include forebay for floatables and afterbay for collection of effluent. (WEF & ASCE, 1998)
- The sediment-retaining baffle must be upstream of the plate pack at a minimum height of 18 in. (King County Surface Water Management, 1998).

- Design plates for ease of removal, and cleaning with high-pressure rinse or equivalent.

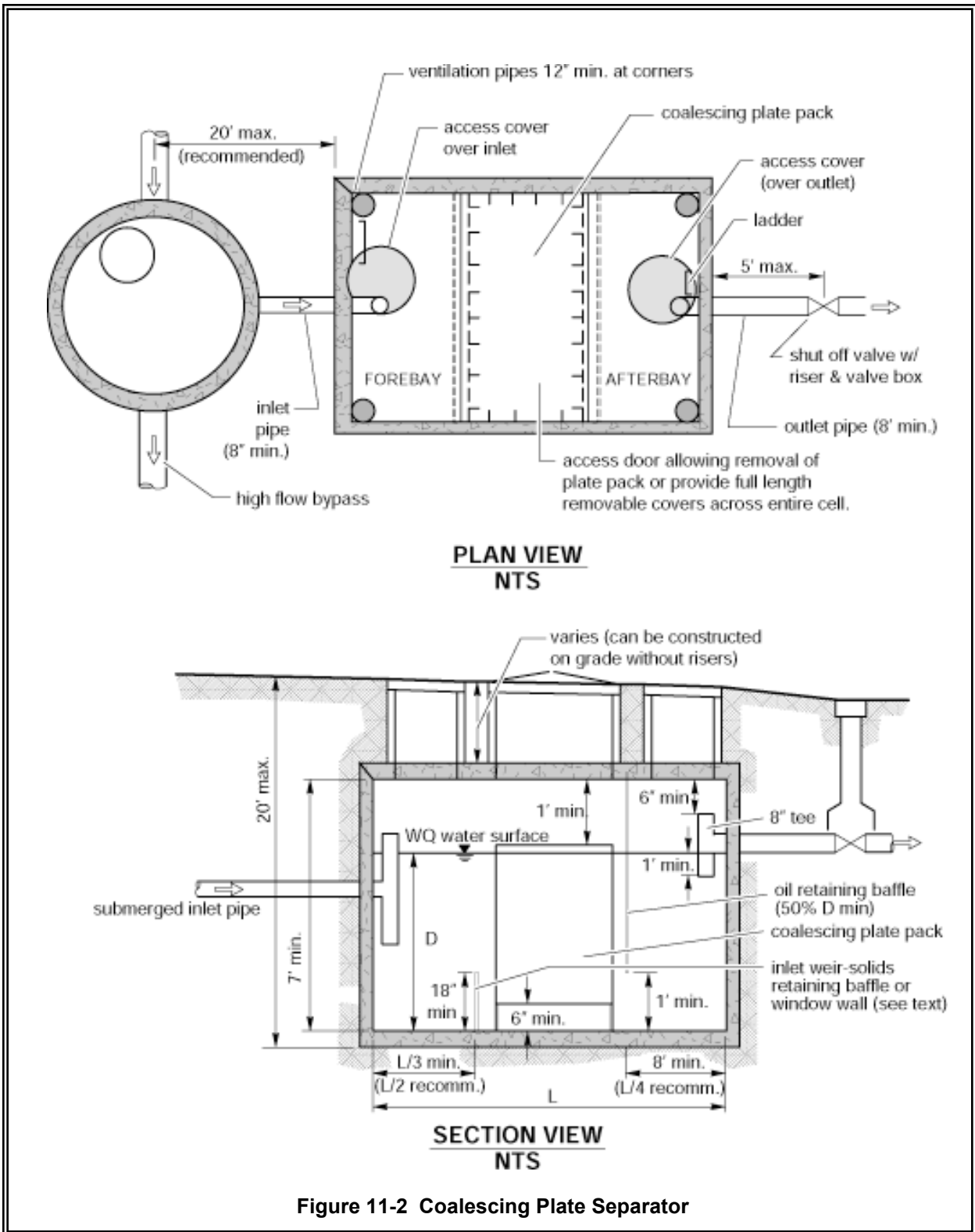
### **Operation and Maintenance**

- Prepare, regularly update, and implement an O & M Manual for the oil/water separators.
- Inspect oil/water separators monthly during the wet season of October 1-April 30 (WEF & ASCE, 1998; Woodward-Clyde Consultants) to ensure proper operation, and, during and immediately after a large storm event of  $\geq 1$  inch per 24 hours.
- Clean oil/water separators regularly to keep accumulated oil from escaping during storms. They must be cleaned by October 15 to remove material that has accumulated during the dry season (Woodward-Clyde Consultants), after all spills, and after a significant storm. Coalescing plates may be cleaned in-situ or after removal from the separator. An eductor truck may be used for oil, sludge, and washwater removal. (King County Surface Water Management, 1998) Replace wash water in the separator with clean water before returning it to service.
- Remove the accumulated oil when the thickness reaches 1-inch. Also remove sludge deposits when the thickness reaches 6 inches (King County Surface Water Management, 1998).
- Replace oil absorbent pads before their sorbed oil content reaches capacity.
- Train designated employees on appropriate separator operation, inspection, record keeping, and maintenance procedures.

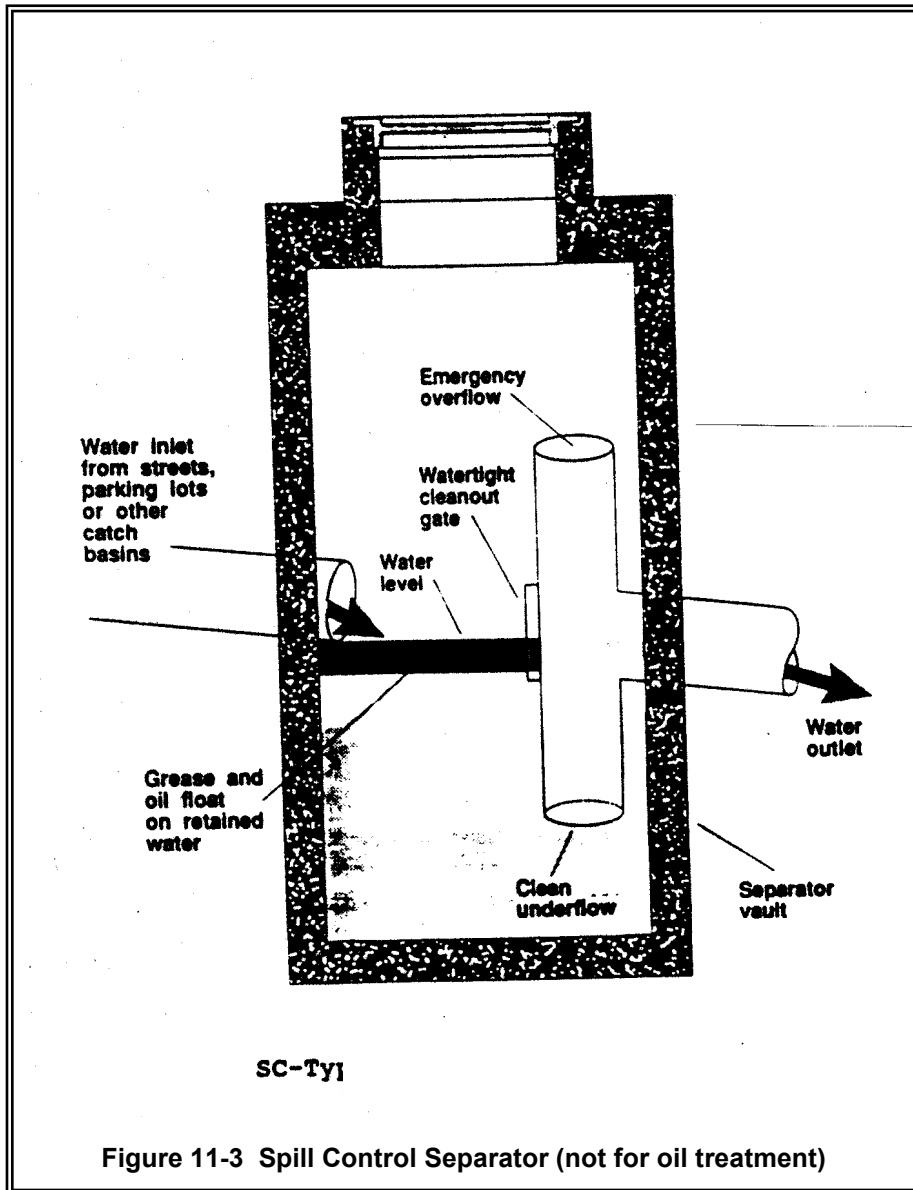


Source: King County (reproduced with permission)





Source: King County (reproduced with permission)



Source: 1992 Ecology Manual

# Chapter 12 - Emerging Technologies

---

This Chapter addresses emerging (new) technologies that have not been evaluated in sufficient detail to be acceptable for general usage in new development or redevelopment situations.

## 12.1 Background

Emerging technologies are new technologies that have not been evaluated using approved protocols, but for which preliminary data indicate that they may provide a desirable level of storm water pollutant removal. Some emerging technologies have already been installed in Washington as parts of treatment trains or as stand-alone systems for specific applications. In some cases, emerging technologies are necessary to remove metals, hydrocarbons, and nutrients. Emerging technologies can also be used for retrofits and where land availability is unavailable for larger natural systems.

To achieve the goals of the Clean Water Act or to comply with its NPDES permit, the City may find it necessary to require developments to retrofit existing storm water discharges if water quality is impacted by the existing development. In retrofit situations, the use of any BMPs that make substantial progress toward these goals is a step forward and is encouraged by Ecology. To the extent practical, the performance of these BMPs should be evaluated, using approved protocols (see below).

## 12.2 Ecology Role in Evaluating Emerging Technologies

Ecology recognizes the need to participate in a process to evaluate emerging technologies and to convey judgments made by local jurisdictions and others on their acceptance. Based on recommendations from Ecology's Volume V Stormwater Technical Advisory Committee (TAC), Ecology plans to implement the following process:

- To develop a website for publishing information on emerging technologies and protocols used in their evaluation,
- To organize and convene a Technical Review Committee (TRC) which will be asked to evaluate emerging technologies,
- To use Best Professional Judgment (BPJ) in the interim, with input from its TRC, in assessing levels of developments of emerging technologies.

An emerging technology *must not be used* for new development sites unless there are data indicating that its performance is expected to be reasonably equivalent to a Basic Treatment, or as part of a treatment train. The latest performance verification of an emerging technology is available on Ecology's website. This manual will be updated as information is available.

### **12.3 Acceptable Evaluation Protocol (APWA Task Committee, 1999)**

To properly evaluate new technologies, performance data must be obtained using an accepted protocol. Such a protocol has been drafted by the Washington State Chapter of the APWA. Ecology plans to publish the final version of the APWA Protocol at its website for use by local governments, suppliers of new technologies, and consultants. The current version can be downloaded from the APWA website at <http://www.mrsc.org/stormwater>. Other acceptable protocols may also be added to Ecology's website.

### **12.4 Assessing Levels of Development of Emerging Technologies**

Ecology has received several submittals from vendors to approve their new technologies for statewide applications. However, none of the submittals included performance information using the APWA, or equivalent protocol. Moreover, it is evident that some technologies have been under development for many years and have been improved considerably during that time.

To assess and classify levels of developments, Ecology is proposing to use the criteria given below. These criteria will be included on the planned website. Emerging technologies shall be used only within the application criteria and performance limits listed at Ecology's website. Best Professional judgment may be used in the interim until the APWA-TRC process is operational.

- *Pilot Level* - Pilot studies could typically be conducted at roadway, commercial and residential sites, or specific land uses for which the system is marketed. Runoff at each site should be tested at full flow (design flow) conditions using reasonable evaluation criteria before deciding on a limited or general statewide use of the technology. The pilot studies should be conducted during dry and wet seasons.
- *General Statewide Use* - To obtain general statewide acceptance the performance criteria as specified in Chapter 3 must be met using the APWA protocol, or other acceptable protocol. Final application, design and O&M criteria, and costs must be determined. Approvals may include application as part of a treatment train and/or as a stand-alone BMP.

### **12.5 Examples of Emerging Technologies for Stormwater Treatment and Control**

The descriptions and other supplier information provided in this section should not be construed as approvals by Ecology of any of the technologies. Suppliers of these emerging technologies are encouraged to submit performance verification data to Ecology in accordance with the APWA-TRC process described earlier in this chapter.

## 12.5.1 Media Filters

### *Introduction*

The media filter technology has been under development in the Pacific Northwest since the early 1990s. During the early stages of development, a leaf compost medium was used in fixed beds, replacing sand. Continued development of this technology is based on placing the media in filter cartridges (vertical media filters) instead of fixed beds, and amending the media (Varner, Phyllis, City of Bellevue, 1999) with constituents that will improve effectiveness (See Figure 12.1). Many systems have been installed in the U.S. The primary target pollutants for removal are: TSS, total and soluble phosphorous, total nitrogen, soluble metals, and oil & grease and other organics. See Table 3.2 and Section 3.3 for Ecology Approved uses of Media Filters.

**Description:** The media can be housed in cartridge filters enclosed in concrete vaults, or in fixed beds such as the sand filters described in Chapter 8. An assortment of filter media are available including leaf compost, pleated fabric, activated charcoal, perlite, amended sand and perlite, and zeolite. The system functions by routing the storm water through the filtering or sorbing medium, which traps particulates and/or soluble pollutants. (Leif, Bill, 1999; Stormwater Management Company, 1999)

**Performance Objectives** Media can be selected for removal of TSS, oil/grease or total petroleum hydrocarbons, soluble metals, nutrients and organics. (See Chapter 4 for performance objectives.)

**Applications and limitations:** Typical applications and limitations include:

- Pretreatment is required for high TSS and/or hydrocarbon loadings and debris that could cause premature failures due to clogging
- Media filtration, such as amended sand, (Varner, Phyllis, City of Bellevue, 1999) should be considered for some enhanced treatment applications to remove soluble metals and soluble phosphates
- These systems may be designed as on-line systems for small drainage areas, or as off-line systems.
- For off-line applications, flows greater than the design flow shall be bypassed.

**Site Suitability** Consider:

- Space requirements
- Design flow characteristics
- Target pollutants
- O & M requirements
- Capital and annual costs

**Design Criteria for TSS Removal)**

- Determine TSS loading and peak design flow.
- TSS loading capacity per cartridge based on manufacturer's loading and flow design criteria to determine number and size of cartridges.

**Pretreatment and Bypassing:**

- Evaluate for pre-treatment needs. Typically, roadways, single family dwellings, and developments with steep slopes and erodible soils need pretreatment for TSS. Developments producing sustained oil and grease loads should be evaluated for oil and grease pretreatment needs.
- Select media based on pollutants of concern . See Chapter 2 of Volume I for geographic specific requirements.
- Use source control where feasible, including gross pollutant removal, sweeping, and spill containment
- Maintain catchbasins as needed to minimize inlet debris that could impair the operation of the filter media.
- Sedimentation vaults/ponds/ tanks, innovative more efficient catchbasins, oil/water separators for oil > 25 ppm, or other appropriate pre-treatment system to improve and maintain the operational efficiency of the filter media
- Bypassing of flows above design flows should be included

**Construction**

- A precast or cast-in-place vault is typically installed over an underdrain manifold pipe system. This is followed by installation of the cartridges.
- Prior to cartridge installation construction sites must be stabilized to prevent erosion and solids loading.

**Maintenance**

- Follow manufacturers O & M guidelines to maintain design flows and pollutant removals
- Based on TSS loading and cartridge capacity calculate maintenance frequency

**Additional Applications, Limitations, Design, Construction, and Maintenance Criteria** (See Ecology web site when available).

**12.5.2 Amended Sand Filters**

**Description**

The addition of media to improve the pollutant removal capabilities of basic sand filters.

**Recent Performance Results**

In a thorough study (Varner, Phyllis, City of Bellevue, 1999) of the performance of sand filters amended with processed steel fiber (95% sand and 5% processed steel fiber by volume), and crushed calcitic limestone (90% sand and 10% crushed calcitic limestone by volume), the City of Bellevue reported significant reductions in total phosphorus and dissolved zinc in runoff from the Lakemont residential area. Because the Lakemont filter study was a detailed, well-documented, and reviewed analysis of a full scale operation, Ecology considers this technology as sufficiently advanced in development to allow its use as an option under the Enhanced Treatment Menu and the Phosphorus Treatment Menu. Sand filters amended with one of these media should be sized using the design criteria for a basic sand filter. Ecology prefers that these

amendments be tested at another location to confirm the performances achieved by the Lakemont study and to further refine the design criteria.

### **12.5.3 Catch Basin Inserts (CBI)**

#### ***Introduction***

CBIs have been under development for many years in the Puget Sound Basin. They function similarly to media filtration except that they are typically limited by the size of the catchbasin. They also are likely to be maintenance intensive.

#### ***Description***

Catch basin inserts typically consist of the following components:

- A structure (screened box, brackets, etc.) which contains a pollutant removal medium
- A means of suspending the structure in a catch basin
- A filter medium such as sand, carbon, fabric, etc.
- A primary inlet and outlet for the storm water
- A secondary outlet for bypassing flows that exceed design flow

#### ***Applications and Limitations***

By treating runoff close to its source, the volume of flow is minimized and more effective pollutant removal is therefore possible. Depending on the insert medium, removals of TSS, organics (including oils), and metals can be achieved. The main drawbacks are the limited retention capacities and maintenance requirements on the order of once per month in the wet season to clean or replace the medium. Based on two studies of catch basin inserts (Koon, John, Interagency Catchbasin Insert Committee, 1995; Leif, William, Snohomish County 1998), the following are potential limitations and applications for specifically designated CBIs.

- CBIs are not recommended as a substitute for basic BMPs such as wet ponds, vaults, constructed wetlands, grass swales, sand filters or related BMPs.
- CBIs can be used as temporary sediment control devices and pretreatment at construction sites.
- CBIs can be considered for oil control at small sites where the insert medium has sufficient hydrocarbon loading capacity and rate of removal, and the TSS and debris will not prematurely clog the insert.
- CBIs can be used in unpaved areas and should be considered equivalent to currently accepted inlet protection BMPs.
- CBIs can be used when an existing catch basin lacks a sump or has an undersized sump.
- CBIs can cause flooding when plugged.
- CBIs may be considered in specialized small drainage applications for specific target pollutants where clogging of the medium will not be a problem.

#### **12.5.4 Manufactured Storm Drain Structures**

Most of these types of systems marketed thus far are cylindrical in shape and are designed to fit into or adjacent to existing storm drainage systems or catch basins. The removal mechanisms include vortex-enhanced sedimentation, circular screening, and engineered designs of internal components, for large particle TSS and large oil droplets.

##### **1. Vortex-enhanced Sedimentation**

###### ***Description:***

Vortex-enhanced Sedimentation consists of a cylindrical vessel with tangential inlet flow which spirals down the perimeter, thus causing the heavier particles to settle. It uses a vortex-enhanced settling mechanism (swirl-concentration) to capture settleable solids, floatables, and oil and grease. This system includes a wall to separate TSS from oil (see Figure 12.2).

***Applications, Limitations, Design, Construction, and Maintenance Criteria*** (see Ecology website when available).

##### **2. Vortex-enhanced Sedimentation and Media Filtration**

###### ***Description***

This system uses a two-stage approach which includes a Swirl Concentrator followed by a filtration chamber (see Figure 12.3).

***Applications, Limitations, Design, Construction, and Maintenance Criteria*** (see Ecology website when available).

##### **3. Cylindrical Screening System**

###### ***Description:***

This system is comprised of a cylindrical screen and appropriate baffles and inlet/outlet structures to remove debris, large particle TSS, and large oil droplets. It includes an overflow for flows exceeding the design flow. Sorbents can be added to the separation chamber to increase pollutant removal efficiency (see Figure 12.4).

***Applications, Limitations, Design, Construction, and Maintenance Criteria*** (See Ecology website when available).

##### **4. Engineered Cylindrical Sedimentation**

###### ***Description:***

This system is comprised of an engineered internal baffle arrangement and oil/TSS storage compartment designed to provide considerably better removals of large particle TSS and oil droplets than the standard catchbasins. It includes a bypass of flows higher than design flows, thus preventing scouring of collected solids and oils during the bigger storms (see Figure 12.5).



***Applications, Limitations, Design, Construction, and Maintenance Criteria*** (See Ecology website, when available).

### **12.5.5 High Efficiency Street Sweepers**

***Description:***

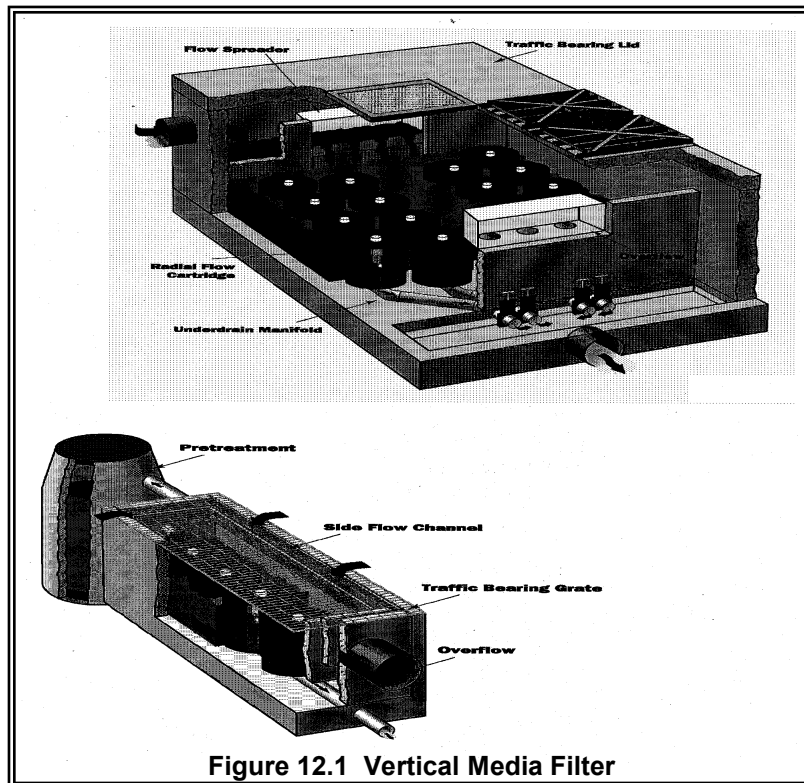
A new generation of street sweepers has been developed that utilize strong vacuums to pick-up small particulates. They include mechanical sweeping and air filtration to control air emissions to acceptable levels. At least two manufacturers market what is referred to as a "high-efficiency" street sweeper.

***Application: (see Ecology website, when available)***

High efficiency street sweepers are being marketed for roadways that are sufficiently accessible, need fine particulate removal (<250 microns), and for which a sufficient frequency of sweeping can be maintained to achieve proper removals of street dirt.

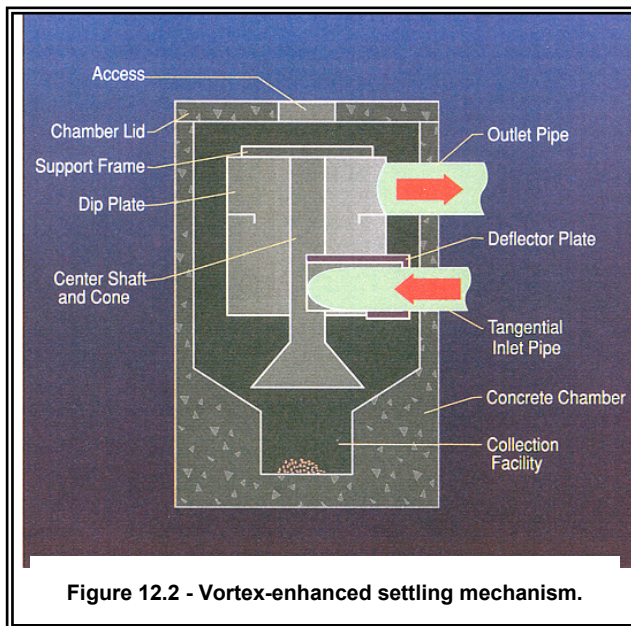
***Limitations:***

- Limited field data and dependence on modeling projections.
- May not be sufficiently effective during wet conditions.
- More expensive than traditional sweepers - the cost of alternative BMPs should be compared.
- Increased storm frequency, with short intervals between storms, results in a need for increased frequency of sweeping.
- May depend on its availability, particularly during the wet season, and the need for a minimum in-place backup treatment facility.



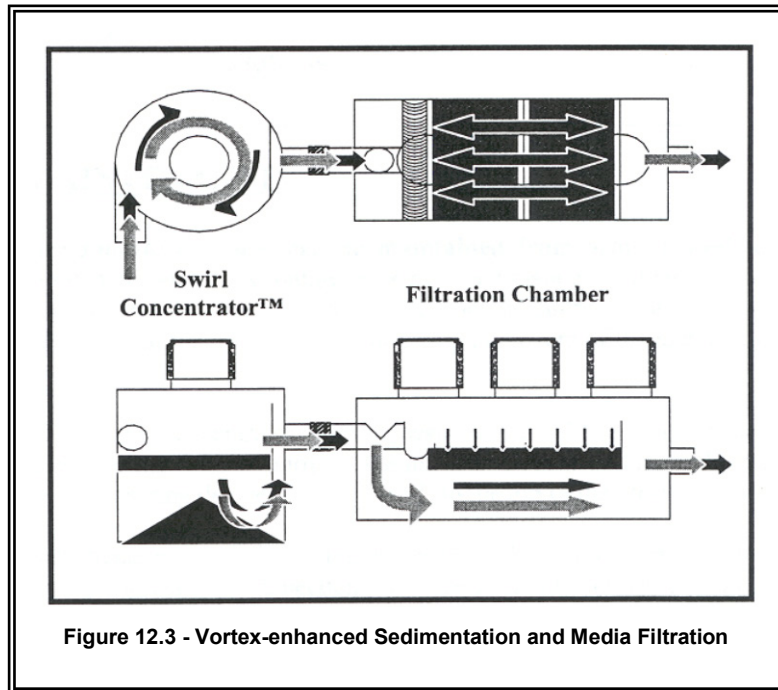
**Figure 12.1 Vertical Media Filter**

Courtesy of Stormwater Management Co.

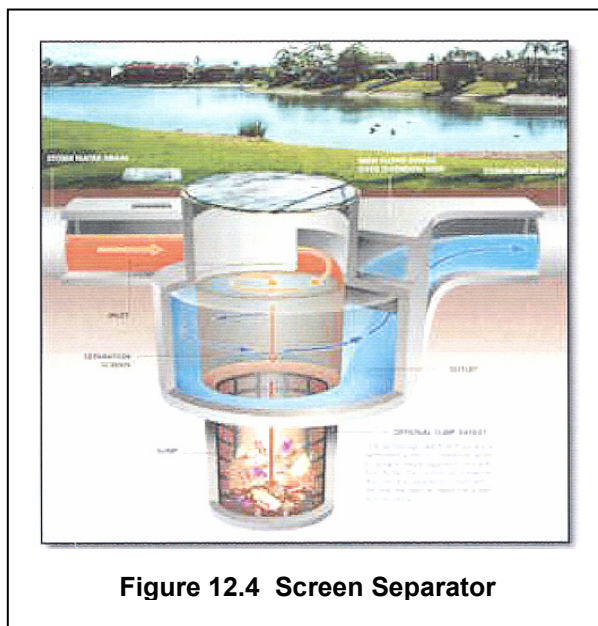


**Figure 12.2 - Vortex-enhanced settling mechanism.**

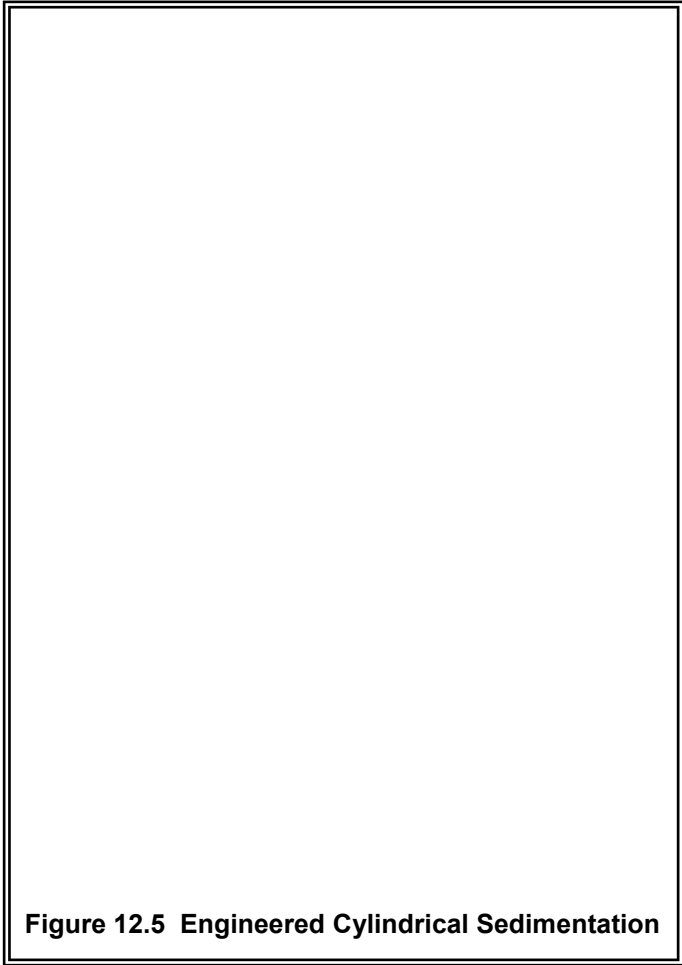
(Courtesy of HIL, Inc.)



(Courtesy of Aquafilter, Inc.)



(Courtesy of CDS, Inc.)



**Figure 12.5 Engineered Cylindrical Sedimentation**

(Courtesy of Stormceptor Co.)

# Appendix V-A

## Basic Treatment Receiving Waters

---

### 1. All Salt Waterbodies

### 2. Rivers

### Basic Treatment Applies Below This Location

Baker	Anderson Creek
Bogachiel	Bear Creek
Cascade	Marblemount
Chehalis	Bunker Creek
Clearwater	Town of Clearwater
Columbia	Canadian Border
Cowlitz	Skate Creek
Elwha	Lake Mills
Green	Howard Hanson Dam
Hoh	South Fork Hoh River
Humptulips	West and East Fork Confluence
Kalama	Italian Creek
Lewis	Swift Reservoir
Muddy	Clear Creek
Nisqually	Alder Lake
Nooksack	Glacier Creek
South Fork Nooksack	Hutchinson Creek
North River	Raymond
Puyallup	Carbon River
Queets	Clearwater River
Quillayute	Bogachiel River
Quinault	Lake Quinault
Sauk	Clear Creek
Satsop	Middle and East Fork Confluence
Skagit	Cascade River
Skokomish	Vance Creek
Skykomish	Beckler River
Snohomish	Snoqualmie River
Snoqualmie	Middle and North Fork Confluence
Sol Duc	Beaver Creek
Stillaguamish	North and South Fork Confluence
North Fork Stillaguamish	Boulder River
South Fork Stillaguamish	Canyon Creek
Suiattle	Darrington
Tilton	Bear Canyon Creek
Toutle	North and South Fork Confluence
North Fork Toutle	Green River
Washougal	Washougal
White	Greenwater River
Wind	Carson
Wynoochee	Wishkah River Road Bridge

**3. Lakes**

Washington  
Sammamish  
Union  
Whatcom  
Silver

**County**

King  
King  
King  
Whatcom  
Cowlitz

Note: Local governments may petition for the addition of more waters to this list. The initial criteria for this list are rivers whose mean annual flow exceeds 1,000 cfs, and lakes whose surface area exceeds 300 acres. Additional waters do not have to meet these criteria, but should have sufficient background dilution capacity to accommodate dissolved metals additions from build-out conditions in the watershed under the latest Comprehensive Land Use Plan and zoning regulations.

# Appendix V-B

## Procedure for Conducting a Pilot Infiltration Test

---

The Pilot Infiltration Test (PIT) consists of a relatively large-scale infiltration test to better approximate infiltration rates for design of stormwater infiltration facilities. The PIT reduces some of the scale errors associated with relatively small-scale double ring infiltrometer or “stove-pipe” infiltration tests. It is not a standard test but rather a practical field procedure recommended by Ecology’s Technical Advisory Committee.

### ***Infiltration Test***

- Excavate the test pit to the depth of the bottom of the proposed infiltration facility. Lay back the slopes sufficiently to avoid caving and erosion during the test.
- The horizontal surface area of the bottom of the test pit should be approximately 100 square feet. For small drainages and where water availability is a problem smaller areas may be considered as determined by the site professional.
- Accurately document the size and geometry of the test pit.
- Install a vertical measuring rod (minimum 5-ft. long) marked in half-inch increments in the center of the pit bottom.
- Use a rigid 6-inch diameter pipe with a splash plate on the bottom to convey water to the pit and reduce side-wall erosion or excessive disturbance of the pond bottom. Excessive erosion and bottom disturbance will result in clogging of the infiltration receptor and yield lower than actual infiltration rates.
- Add water to the pit at a rate that will maintain a water level between 3 and 4 feet above the bottom of the pit. A rotameter can be used to measure the flow rate into the pit.

*Note: A water level of 3 to 4 feet provides for easier measurement and flow stabilization control. However, the depth should not exceed the proposed maximum depth of water expected in the completed facility.*

Every 15-30 min, record the cumulative volume and instantaneous flow rate in gallons per minute necessary to maintain the water level at the same point (between 3 and 4 feet) on the measuring rod.

Add water to the pit until one hour after the flow rate into the pit has stabilized (constant flow rate) while maintaining the same pond water level. (usually 17 hours)

After the flow rate has stabilized, turn off the water and record the rate of infiltration in inches per hour from the measuring rod data, until the pit is empty.

### ***Data Analysis***

Calculate and record the infiltration rate in inches per hour in 30 minutes or one-hour increments until one hour after the flow has stabilized.

**Note:** Use statistical/trend analysis to obtain the hourly flow rate when the flow stabilizes. This would be the lowest hourly flow rate.

Apply appropriate correction factors for site heterogeneity, anticipated level of maintenance and treatment to determine the site-specific design infiltration rate (see Table 7.3).

***Example***

The area of the bottom of the test pit is 8.5-ft. by 11.5-ft.

Water flow rate was measured and recorded at intervals ranging from 15 to 30 minutes throughout the test. Between 400 minutes and 1,000 minutes the flow rate stabilized between 10 and 12.5 gallons per minute or 600 to 750 gallons per hour, or an average of  $(9.8 + 12.3) / 2 = 11.1$  inches per hour.

Applying a correction factor of 5.5 for gravelly sand in table 6.3 the design long-term infiltration rate becomes 2 inches per hour, anticipating adequate maintenance and pre-treatment.



# Appendix V-C

## Geotextile Specifications

Table 1 Geotextile properties for underground drainage. Geotextile Property Requirements <sup>1</sup>			
		Low Survivability	Moderate Survivability
Geotextile Property	Test Method	Woven/Nonwoven	Woven/Nonwoven
Grab Tensile Strength, min. in machine and x-machine direction	ASTM D4632	180 lbs/115 lbs min.	250 lbs/160 lbs min.
Grab Failure Strain, in machine and x-machine direction	ASTM D4632	<50%/>50%	<50%/>50%
Seam Breaking Strength (if seams are present)	ASTM D4632 and ASTM D4884 (adapted for grab test)	160 lbs/100 lbs min.	220 lbs/140 lbs min.
Puncture Resistance	ASTM D4833	67 lbs/40 lbs min.	80 lbs/50 lbs min.
Tear Strength, min. in machine and x-machine direction	ASTM D4533	67 lbs/40 lbs min.	80 lbs/50 lbs min.
Ultraviolet (UV) Radiation stability	ASTM D4355	50% strength retained min., after 500 hrs. in weatherometer	50% strength retained min., after 500 hrs. in weatherometer

<sup>1</sup> All geotextile properties are minimum average roll values (i.e., the test result for any sampled roll in a lot shall meet or exceed the values shown in the table).

Table 2 Geotextile for underground drainage filtration properties. Geotextile Property Requirements <sup>1</sup>				
Geotextile Property	Test Method	Class A	Class B	Class C
AOS <sup>2</sup>	ASTM D4751	.43 mm max. (#40 sieve)	.25 mm max. (#60 sieve)	.18 mm max. (#80 sieve)
Water Permittivity	ASTM D4491	.5 sec -1 min.	.4 sec -1 min.	.3 sec -1 min.

<sup>1</sup> All geotextile properties are minimum average roll values (i.e., the test result for any sampled roll in a lot shall meet or exceed the values shown in the table).

<sup>2</sup> Apparent Opening Size (measure of diameter of the pores in the geotextile)

<b>Table 3 Geotextile strength properties for impermeable liner protection.</b>		
<b>Geotextile Property</b>	<b>Test Method</b>	<b>Geotextile Property Requirements<sup>1</sup></b>
Grab Tensile Strength, min. in machine and x-machine direction	ASTM D4632	250 lbs min.
Grab Failure Strain, in machine and x-machine direction	ASTM D4632	>50%
Seam Breaking Strength (if seams are present)	ASTM D4632 and ASTM D4884 (adapted for grab test)	220 lbs min.
Puncture Resistance	ASTM D4833	125 lbs min.
Tear Strength, min. in machine and x-machine direction	ASTM D4533	90 lbs min.
Ultraviolet (UV) Radiation	ASTM D4355	50% strength stability retained min., after 500 hrs. in weatherometer

<sup>1</sup> All geotextile properties are minimum average roll values (i.e., the test result for any sampled roll in a lot shall meet or exceed the values shown in the table).

### **Applications**

1. For sand filter drain strip between the sand and the drain rock or gravel layers specify Geotextile Properties for Underground Drainage, moderate survivability, Class A, from Tables 1 and 2 in the Geotextile Specifications.
2. For sand filter matting located immediately above the impermeable liner and below the drains, the function of the geotextile is to protect the impermeable liner by acting as a cushion. The specification provided below in Table 3 should be used to specify survivability properties for the liner protection application. Table 2, Class C should be used for filtration properties. Only nonwoven geotextiles are appropriate for the liner protection application.
3. For an infiltration drain specify Geotextile for Underground Drainage, low survivability, Class C, from Tables 1 and 2 in the Geotextile Specifications.
4. For a sand bed cover a geotextile fabric is placed exposed on top of the sand layer to trap debris brought in by the storm water and to protect the sand, facilitating easy cleaning of the surface of the sand layer. However, a geotextile is not the best product for this application. A polyethylene or polypropylene geonet would be better. The geonet material should have high UV resistance (90% or more strength retained after 500 hours in the weatherometer, ASTM D4355), and high permittivity (ASTM D4491, 0.8 sec. -1 or more) and percent open area (CWO-22125, 10% or more). Tensile strength should be on the order of 200 lbs grab (ASTM D4632) or more.

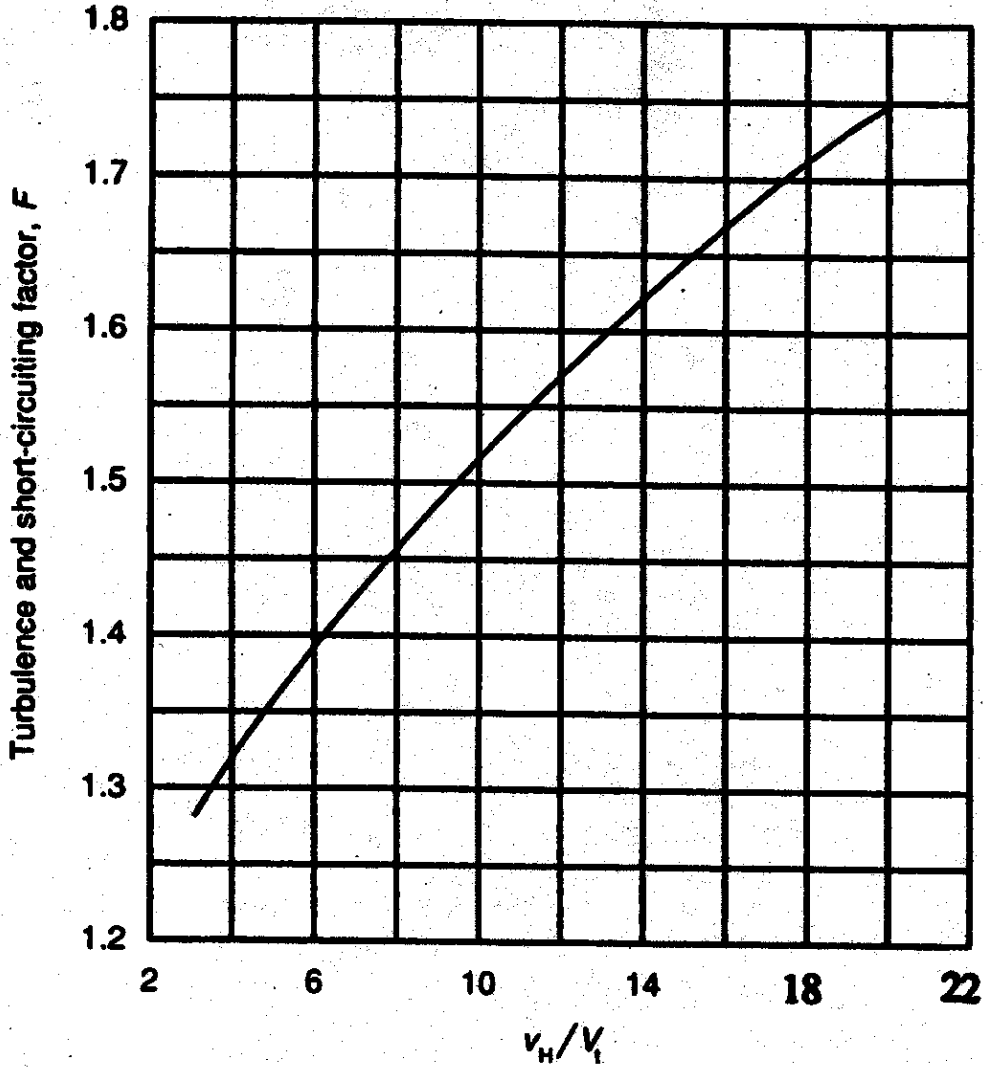
**Courtesy of Tony Allen, Geotechnical Engineer-WSDOT**

**Reference for Tables 1 and 2: Section 9-33.2 "Geotextile Properties," 1998 Standard Specifications for Road, Bridge, and Municipal Construction**

# Appendix V-D

## Turbulence and Short-Circuiting Factor

---



$v_H/V_t$	Turbulence Factor ( $F_t$ )	$F = 1.2(F_t)$
20	1.45	1.74
15	1.37	1.64
10	1.27	1.52
6	1.14	1.37
3	1.07	1.28

Figure D.1 Recommended Values of  $F$  for Various Values of  $v_H/V_t$

## Volume V References

---

- Allen, Tony (Recommendations by) -Geotechnical Engineer, WSDOT, 1999
- American Petroleum Institute, "Design and Operation of Oil-Water Separators," Publication 421, Feb. 1990.
- APWA Task Committee, "Protocol for the Acceptance of Unapproved Stormwater Treatment Technologies for Use in the Puget Sound Watershed, November 1999.
- Aquashield Inc., "Aquafilter Stormwater Filtration System", 2000.
- ASCE and WEF, Urban Runoff Quality Management, WEF Manual of Practice No. 23, 1998.
- Caraco, Deborah and Richard Claytor, Stormwater BMP Design Supplement for Cold Climates, Center for Watershed Protection, December 1997.
- Center for Watershed Protection, "Better Site Design", August 1998.
- Chang, George, C., "Review of Stormwater Manual-Sand Filtration Basins for Department of Ecology, State of Washington", November 5, 2000.
- Chin, D. A. Water Resources Engineering, Prentice Hall, New Jersey, 2000.
- Chow, V.T., "Open Channel Hydraulics", McGraw-Hill Book Co., New York, 1959.
- City of Austin, Texas. Design Guidelines for Water Quality Control Basins, Environmental Criteria Manual, June 1988.
- Claytor, Richard and Thomas Schueler, Design of Stormwater Filter Systems, December 1996
- Colwell, S.R., "Characterization of Performance Predictors and Evaluation of Mowing Practices in Biofiltration Swales." MSCE Thesis, U. of Washington, 2000.
- Corbitt, Robert A., "Oil and Grease Removal," Handbook of Environmental Engineering, McGraw-Hill, Inc., 1990.
- CSR-HydroConduit, "The Stormceptor System Technical Manual", 1997.
- Ferguson, Bruce K., Stormwater Infiltration, Lewis Publishers, 1994.
- Ferguson, Bruce K., Review of Draft Stormwater Manual for Western Washington (Infiltration Sections of Volume III and Volume V), October 2000.
- Goldman, S.J., K. Jackson and T.A. Bursztynsky, "Erosion and Sediment Control Handbook" McGraw-Hill Book Co., New York, 1986.
- H.I.L. Technology, Inc.," Downstream Defender", 1998.

- Horner, R., "Fundamentals of Urban Runoff Management-Technical and Institutional Issues", 1994.
- Horner, Richard "Review of Stormwater Manual." October 23, 2000.
- Jaisinghani, R., A., et. al., "A Study of Oil/Water Separation in Corrugated Plate Separators," Journal of Engineering for Industry, 11/79.
- King County Surface Water Management, "High Use/Oil Control Decision Paper," Draft, 1994.
- King County Surface Water Management, Design Manual, September, 1998.
- King County Surface Water Management, WA, "Draft Guidelines for Full-Scale Infiltration Facility Testing", February, 2001.
- Koon, John, "Evaluation of Water Quality Ponds and Swales in the Issaquah/East Sammamish Basins", King County Surface Water Management, 1995.
- Koon, John, et al, "Evaluation of Commercial-Available Catch basin Inserts for the Treatment of Stormwater Runoff from Developed Sites", Interagency Catch basin Insert Committee, 1995.
- Kulzer, Louise and Horner, Richard, et. al., "Biofiltration Swale Performance, Recommendations, and Design Considerations", Municipality of Metropolitan Seattle. Publication 657, October 1992
- Lambert, C., "Stormceptor", CSR, Inc., July 2000.
- Lee, D., T.A. Dillaha and J.H. Sherrard, "Modeling Phosphorus Transport in Grass Buffer Strips." Journal of Environmental Engineering, Volume 115, No. 2, New York, N.Y., April, 1989.
- Leif, Bill, "Compost Stormwater Filter Evaluation", January 1999.
- Leif, William, "Sediment Removal in Catch Basin Inserts", Snohomish County, March 1998.
- Massmann, Joel and Carolyn Butchart. Infiltration Characteristics, Performance, and Design of Storm Water Facilities, U. of Washington, March 2000.
- Mazer, Greg, "Environmental Limitations to Vegetation Establishment and Growth in Vegetated Stormwater Biofilters." University of Washington, July 1998.
- Minton, Gary, "Planning Report No. 3: Sizing Oil/Water Separators for the Redmond Way Storm Drain System", Resource Planning Associates, 1990.
- Minton, G., The Selection and Sizing of Treatment BMPs in New Developments to Achieve Water Quality Objectives, March 1993.
- No. Carolina DEHNR, "Stormwater Best Management Practices", November 1995.

- Rawls, W. J., D. L. Brakensiek, and K. E. Saxton. Estimation of Soil Properties. Transactions of the American Society of Agricultural Engineers, Vol. 25, No. 5, pp. 1316-1320, 1982.
- Schueler, Thomas R., "Water Quality inlets/Oil Grit Separators," BMP Fact Sheet #11, Current Assessment of Urban Best Management Practices, March 1992.
- Schueler, Tom, et. al., "A Current Assessment of Urban Best Management Practices", March 1992.
- Seattle METRO, "Oil and Water Don't Mix," October 1990.
- Shaver, Earl, Sand Filter Design for Water Quality Treatment, Delaware Department of Natural Resources and Environmental Control, 1992.
- SPE Production Engineering, "Droplet-Settling vs. Retention-Time Theories for Sizing Oil/Water Separator," Kenneth Arnold, et. al., February 1990.
- Stenstrom, Michael, et. al., "Oil and Grease in Urban Stormwater," 1983 paper for publication in Journal of Environ. Engineering.
- Stormwater Management Co., "Stormfilter Product Manual", 1999.
- Strynchuk, Justin, et al, "The Use of a CDS Unit for Sediment Control in Brevard County, April, 2000.
- Sutherland, Roger, et al, "High Efficiency Sweeping as an Alternative to the Use of Wet Vaults for Stormwater Treatment," 1998.
- Thurston County Environmental Health, "Oil/Water Separator Fact Sheet," circa 1995.
- U.S. Air Force, "Gravity Oil and Water Separator Design Criteria," circa 1991.
- U.S. Army Corps. of Engineers, "Selection and Design of Oil and Water Separators," August 26, 1994.
- U.S. Army Corps. of Engrs., "Prefabricated Oil-Water Separators," Draft Specifications, 1995.
- U.S. Dept. of Commerce, Bureau of Public Roads, "Design Charts for Open-Channel Flow, Hydraulic Design Series 3", Washington, D.C., 1961.
- Urbonas, Ben, Hydraulic Design of Sand Filters for Stormwater Quality, 1997.
- USEPA, "Stormwater BMP Design Supplement for Cold Climates", December 1997.
- Varner, Phyllis, et al, "Lakemont Stormwater Treatment Facility Monitoring Report," City of Bellevue, November 1999.
- Wa. Dept. of Ecology, "NPDES and State Waste Discharge General Permit for Stormwater Discharges Associated with Industrial Activities," November 18, 1995.

- Wang T.S., D.E. Spyridakis, B.W. Mar, and R.R. Horner, "Transport, Deposition and Control of Heavy Metals in Highway Runoff." FHWA-WA-RD-39.10. Report to Washington State Department of Transportation by Department of Civil Engineering, University of Washington, Seattle, 1982
- Water Environment Federation, "Urban Runoff Quality Management", American Society of Civil Engineers, 1998.
- Water Pollution Control Federation, "Clarifier Design," Manual of Practice FD-8, 1985.
- Watershed Protection Techniques, "Hydrocarbon Hotspots in the Urban Landscape: Can They be Controlled?", Feb. 1994.
- WEF & ASCE, "Urban Runoff Quality Management, 1998.
- Wiltsie, Edward, Stormwater Facilities Performance Study, Infiltration Pond Testing and Data Evaluation, August 10, 1998.
- Woinsky, S. G., "New Advanced Solids/Oil/Water Separator," Environmental Progress, Feb. 1995.
- Wong, S.L., and R.H. McKuen, "The Design of Vegetative Buffer Strips for Runoff and Sediment Control", Report to the Maryland Coastal Zone Management Program, University of Maryland, College Park, Maryland, 1981.
- Woodward-Clyde Consultants (Recommendations by), "Biofiltration Swales and Filter Strips", November 1995.
- Woodward-Clyde Consultants "Oil/Water Separators."
- Woodward-Clyde Consultants, Recommendations for Revising Ecology's Manual, November 1995.